

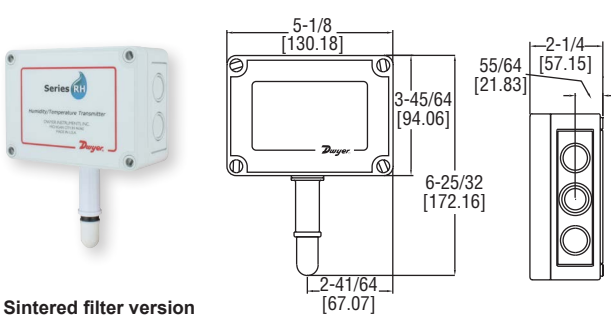

Series RHP Temperature/Humidity Transmitter

Specifications - Installation and Operating Instructions



Sintered filter version

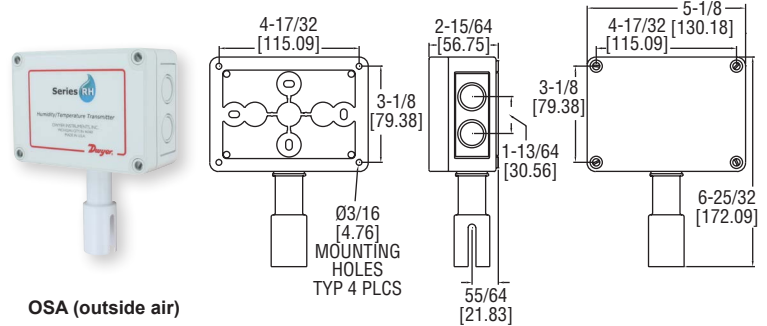

OSA (outside air)

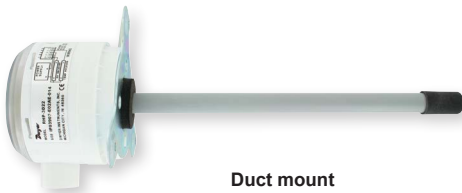

Duct mount

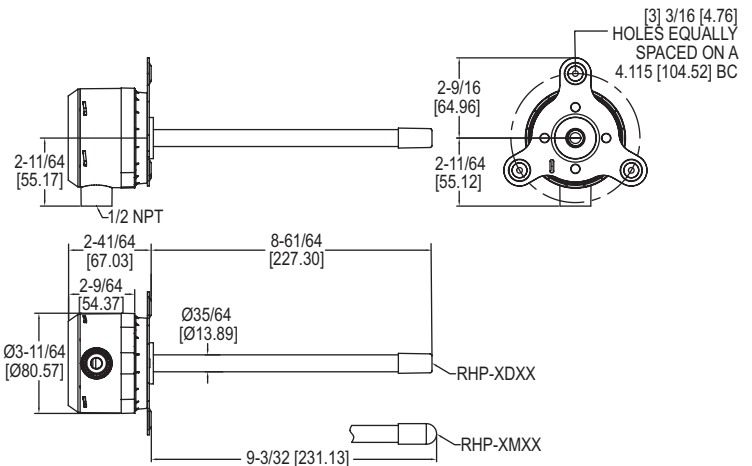

The **Series RHP Humidity and Temperature Transmitter** offers flexibility, high accuracy, long term stability, and reliable operation. Utilizing the duct and outside air mounting configurations, the Series RHP monitors and controls humidity or both humidity and temperature in a building energy management systems, commercial and residential HVAC applications, clean rooms, museums, and climate chambers.

The Series RHP can be ordered with a single current or voltage output for humidity or can be factory configured to have an additional current, voltage, or passive RTD or thermistor temperature output. The optional display for the duct mount models allows the user to read both the temperature and humidity simultaneously.

NOTICE

For best results, our model RHRS radiation shield is recommended for sintered filter versions of the outside air transmitter.

NOTICE

Sensor is sensitive to Electro-Static Discharge (ESD). Follow industry standard practice for control and protection against ESD. Failure to exercise good ESD practices may cause damage to the sensor.

SPECIFICATIONS

Relative Humidity Range: 0 to 100% RH.

Temperature Range: -40 to 140°F (-40 to 60°C).

Accuracy, RH: Model RHP2 ±2% 10-90% RH @ 25°C; Model RHP3 ±3% 20-80% RH @ 25°C.

Accuracy, Thermistor Temp Sensor: ±0.22°C @ 25°C (±0.4°F @ 77°F).

Accuracy, RTD Temp Sensor: DIN Class B; ±0.3°C @ 0°C (±0.54°F @ 32°F).

Accuracy, Solid State Temperature Sensor: ±0.9°F @ 72°F (±0.3°C @ 25°C)

Hysteresis: ±1%.

Repeatability: ±0.1% typical.

Temperature Limits: -40 to 140°F (-40 to 60°C).

Storage Temperature: -40 to 176°F (-40 to 80°C).

Compensated Temperature Range: -4 to 140°F (-20 to 60°C).

4 to 20 mA Loop Powered Models: Power requirements: 10 to 35 VDC; Output signal: 4 to 20 mA, 2 channels for humidity/solid state temperature, sensor models (loop powered on RH).

0 to 5, 0 to 10 V Output Models: Power requirements: 15 to 35 VDC or 15 to 29 VAC; Output signal: 0 to 5, 0 to 10 V @ 5 mA max, 2 channels for humidity/solid state temperature sensor models.

Response Time: 15 seconds.

Electrical Connections: Removable screw terminal block.

Conduit Connection: Duct mount: 1/2" NPS; OSA: 1/2" (22.3 mm).

Drift: <1% RH/year.

RH Sensor: Capacitance polymer.

Temperature Sensor: Curves A,B,C, F: Thermistor; Curves D,E: Platinum RTD DIN 385; Curve 0: None; Curve 1,2: Solid state band gap.

Housing Material: Duct mount: PBT; OSA: Polycarbonate.

Enclosure Rating: Duct mount: NEMA 4X (IP65) for housing only; OSA: NEMA 4X (IP65).

Display: Duct mount only, Optional 2-line alpha numeric, 8 characters/line.

Display Resolution: RH: 0.1%; 0.1°F (0.1°C).

Weight: Duct mount .616 (.3 kg) OSA 1 lb (.45 kg).

Agency Approvals: CE.

INSTALLATION

WARNING Disconnect power supply before installation to prevent electrical shock and equipment damage.

Make sure all connections are in accordance with the job wiring diagram and in accordance with national and local electrical codes. Use copper conductors only.

CAUTION Use electrostatic discharge precautions (e.g., use of wrist straps) during installation and wiring to prevent equipment damage.

Avoid locations where severe shock or vibration, excessive moisture or corrosive fumes are present. NEMA Type 4X (IP65) housings are intended for outdoor use primarily to provide a degree of protection against wind-blown dust, rain, and hose-directed water.

Do not exceed ratings of this device, permanent damage not covered by warranty may result. The 4 to 20 mA models are not designed for AC voltage operation.

Duct Mount

The transmitter should be mounted away from fans, corners, heating and cooling coils, and other equipment that will effect the measurement of the relative humidity. It should also be mounted in a location that receives adequate air flow for proper operation. The transmitter should be mounted such that the conduit connection points down to prevent moisture from entering.

1. Drill a 1" diameter hole into the duct at the desired location.
2. Insert the transmitter probe through the hole such that the mounting flange is flush to the duct.
3. Use three #8 x 1/2" pan head sheet metal screws to attach the mounting flange to the duct. Do not over tighten.
4. Remove top screw cover to access wiring terminals.

OSA (Outside Air)

The transmitter should be mounted under an eave, shield, or in an area that is out of the elements or direct sunlight. The transmitter should be mounted with the sensor pointing down to prevent water collection in the sensor cavity.

1. Remove the cover plugs from the face of the unit and the top cover.
2. Position the transmitter where it is to be mounted and mark the mounting holes in each corner of the housing.
3. Drill or punch out marked locations.
4. Place the transmitter box over mounting holes on wall and align. Install wall mount screws (not provided) in mounting holes.
5. Proceed with wiring according to Figure 1.
6. Replace cover and cover plugs on the face of the unit.

WIRING

Use maximum 18 AWG wire for wiring terminals. Refer to Figure 1 or Figure 2 for wiring information. Terminal blocks are removable for ease of wiring.

4 to 20 mA Output Models with Thermistor, RTD or No Temperature Sensor

4 to 20 mA output units may be powered with a 10 to 35 VDC supply. (Wire as shown in Figure 1).

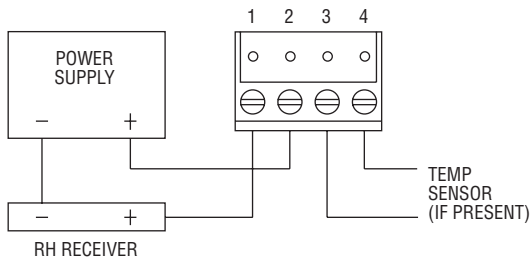

Figure 1

Dual 4 to 20 mA RH/Temperature Output Models

Dual 4 to 20 mA output units may be powered with a 10 to 35 VDC supply. The following describes the proper wiring of these transmitters: The model RHP transmitter with dual 4 to 20 mA output is designed as a two-wire 4 to 20 mA device with two channels. The channels are common on the positive side of the current loop. Sensor excitation power is derived from the RH channel, so power must always be applied to that channel. If the temperature channel is not used, it can be left disconnected. Wire as shown in Figure 2.

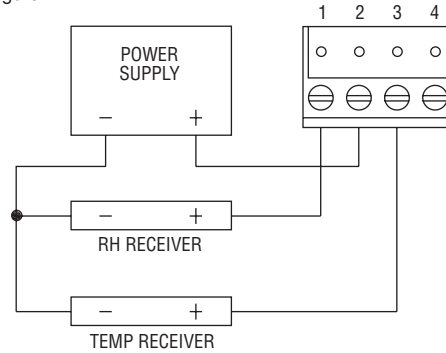

Figure 2

Note: If the RH output is not required, wire the "-" terminal of the power supply to terminal 1.

0 to 5 V and 0 to 10 V Output Models with Thermistor, RTD, or No Temperature Sensor

The 0 to 5 V and 0 to 10 V output models may be powered with 15 to 35 VDC or 15 to 29 VAC. Note polarity when using DC power. The maximum load is 5 mA. Wire as shown in Figure 3.

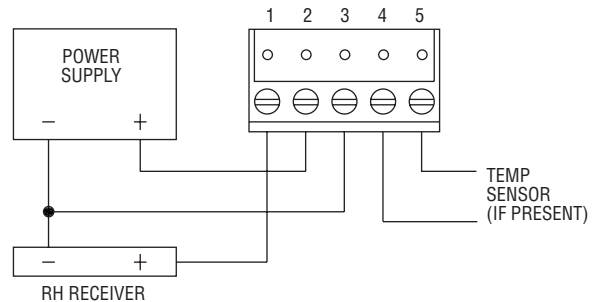

Figure 3

Dual 0 to 5 V and 0 to 10 V RH/Temperature Output Models

Dual 0 to 5 V and 0 to 10 V output units may be powered with 15 to 35 VDC or 15 to 29 VAC. Note polarity when using DC power. The channels are common on the negative side. If desired, the RH or, temperature output may be used by itself. Wire as shown in Figure 4.

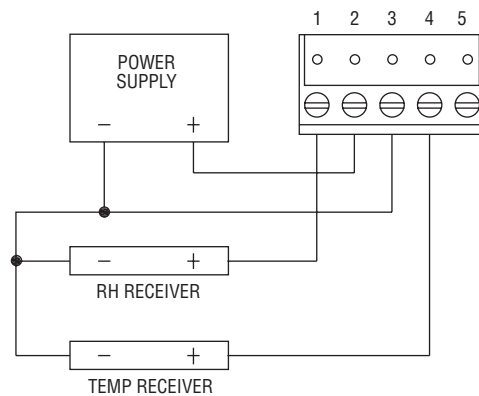

Figure 4

DISPLAY

The temperature indicated on the display, if equipped with the LCD option, is field selectable via a jumper located on the circuit board. Position the jumper for °F or °C according to Figure 5.

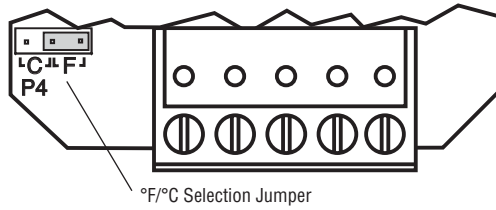

Figure 5

Note: The display will indicate temperature even if the unit does not have a temperature output.

TROUBLESHOOTING

1. Verify that the unit is mounted in the correct position.
2. **4 to 20 mA Models:**

Verify appropriate supply voltage. The transmitter requires a minimum of 10 and a maximum of 35 VDC at its connection for proper operation. Choose a power supply with a voltage and current rating which meets this requirement under all operating conditions. If the power supply is unregulated, make sure voltage remains within these limits under all power line conditions. Ripple on the supply should not exceed 100 mV.

Loop Resistance – The maximum allowable loop resistance depends on the power supply voltage. Maximum loop voltage drop must not reduce the transmitter voltage below the 10 VDC minimum. Maximum loop resistance can be calculated with the following equation. V_{ps} is the power supply voltage.

$$R_{max} = \frac{V_{ps} - 10.0}{20 \text{ mA}}$$

Some receivers, particularly loop powered indicators, may maintain a fixed loop voltage to power the device. This voltage drop must also be subtracted from the power supply voltage when calculating the voltage margin for the transmitter. The following equation takes this into account. V_{rec} is the receiver fixed voltage.

$$R_{max} = \frac{V_{ps} - 10.0 - V_{rec}}{20 \text{ mA}}$$

0 to 5 V and 0 to 10 V Output Models:

Verify appropriate supply voltage. The 0 to 5 V and 0 to 10 V output models require a DC supply of 15 to 35 V or an AC supply of 15 to 29 V for proper operation maximum. Maximum output load is 5 mA.

FIELD SENSOR REPLACEMENT

Replacement sensors are available for OSA sintered filter models (RHP-XSXX) and duct mount models manufactured before February 2015. Sensor covers are also available. Please contact Dwyer technical support for additional details.

MODEL CHART						
Example	RHP	-2	D	1	A	-LCD
Series	RHP					RHP-2D1A-LCD
Accuracy		2 3 5				2% accuracy 3% accuracy 5% accuracy
Housing Type			D M O S R			Duct mount with filter Duct mount with HDPE filter OSA (outside air) OSA with sintered filter Radiation shield
RH Output				1 2 3		4 to 20 mA 0 to 10 V 0 to 5 VDC
Temperature Sensor					A B C D E F 0 1 2 3	10K @ 25°C thermistor Dwyer curve A 10K @ 25°C thermistor Dwyer curve B 3K @ 25°C thermistor Dwyer curve C 100 Ω RTD DIN 385 1K Ω RTD DIN 385 20KC 25°C thermistor curve F No temperature output 4 to 20 mA solid state 0 to 10 V solid state 0 to 5 V
Option						LCD LCD display; Blank; No options

MAINTENANCE

Upon final installation of the Series RHP Temperature/Humidity Transmitter and the companion receiver, no routine maintenance is required. A periodic check of the system calibration is recommended. The Series RHP is not field serviceable and should be returned if repair is needed (field repair should not be attempted and may void warranty). Be sure to include a brief description of the problem plus any relevant application notes. Contact customer service to receive a return goods authorization number before shipping.



This symbol indicates waste electrical products should not be disposed of with household waste. Please recycle where facilities exist. Check with your Local Authority or retailer for recycling advice.