



SERIES MSX PRO | MAGNESENSE® DIFFERENTIAL PRESSURE TRANSMITTER



MSX Pro with optional LCD

BENEFITS/FEATURES

- Easily access the unit's wiring via the flip-lid housing
- Eliminates accidental damage to the unit during installation with the products innovative design shielding the electronics underneath the PCB
- Added security and protection from the tamper-resistant cover
- Protection from liquids and moisture near the cable egress point with the included liquid tight cable gland fitting
- Reduce installation time with quick and easy wiring via the included a toolless terminal block
- Add safety to variety of applications that need to meet municipal and building code standards with UL94 V-0 and plenum ratings

APPLICATIONS

- High performance building applications for critical environments
- Filter monitoring in air handler units
- Building pressure in pharmaceutical/semiconductor clean rooms
- Duct static pressure in commercial and specialized buildings
- Air velocity/flow in VAV systems

DESCRIPTION

The **Series MSX Pro Magnesense® Differential Pressure Transmitter** is the professional differential pressure transmitter meeting stringent industry standards with innovative global product design. The device has exceptional stability for use in critical building performance applications with the popular versatility of our original Series MS2 Magnesense® II transmitter. The MSX Pro simplifies the ordering process to deliver the desired configuration, which reduces product setup time. Pressure ranges of Pa, mm w.c., and in w.c. are available per device. All pressure ranges can be configured in unidirectional or bidirectional modes providing a total of 32 ranges. The MSX Pro transmitter can provide a linear pressure output or a linear velocity output with the square root extraction from the transmitter. Additional parameters have been included to expand the square root capability to calculate flow. Dual voltage and milliamp output signals can be used to provide control and equipment output signal verification.

SPECIFICATIONS

Service	Air and non-combustible, compatible gases.
Wetted Materials	Consult factory.
Accuracy	±0.5% FSO for all ranges except unidirectional .5 in. @ ±1% FSO.
Stability	±1% FSO/year.
Temperature Limits	-4 to 158°F (-20 to 70°C).
Pressure Limits	Ranges 0 and 1: 3.6 psi max operation, 6 psi burst; Ranges 2 and 3: 6 psi max operation, 6 psi burst.
Power Requirements	10-36 VDC (2-wire), 17-36 VDC or isolated 21.6-33 VAC (3-wire).
Output Signals	4-20 mA (2-wire); 0-10 V, 0-5 V (3-wire).
Response Time	Instantaneous (default) or 3 s (selectable).
Zero and Span Adjustments	Digital push-button.
Loop Resistance	Current output: 0-1250 Ω max; Voltage output: min. load resistance 1 kΩ.
Current Consumption	21 mA max continuous.
Electrical Connections	4-wire removable European style terminal block for 16 to 26 AWG.
Electrical Entry	1/2" NPS thread. Cable gland included.
Display (optional)	4 digit LCD.
Process Connections	1/8", 3/16", 1/4", 5 mm, and 6 mm ID flexible tubing.
Enclosure Rating	NEMA 4X (IP66); UL 2043 (Plenum); UL94 V-0.
Mounting Orientation	Pressure sensor measurement unaffected by orientation.
Weight	8.0 oz (230 g).
Agency Approvals	CE.

DIMENSIONS

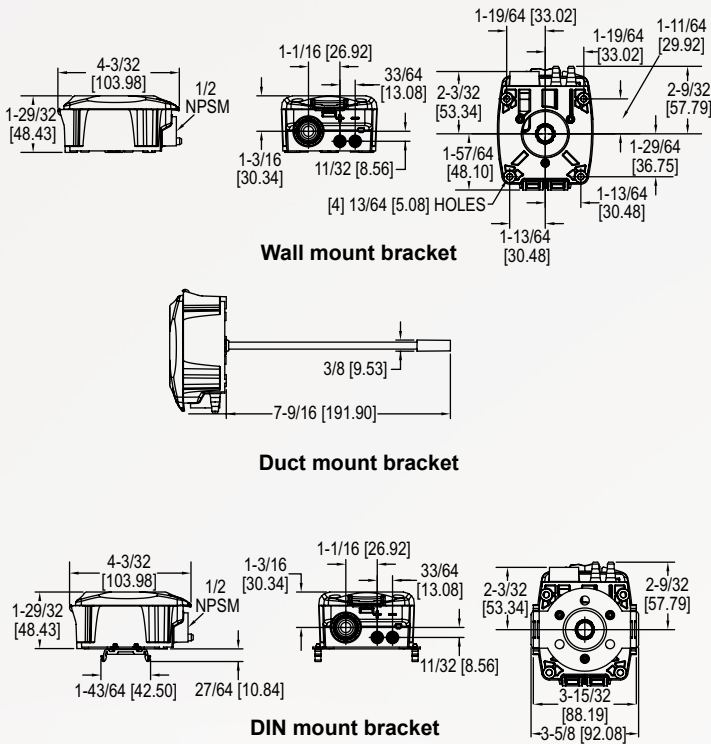

WIRING DIAGRAM

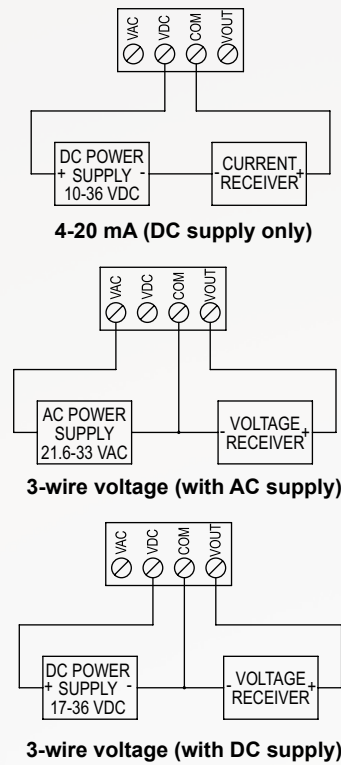

HOW TO ORDER

Use the **bold** characters from the chart below to construct a product code.

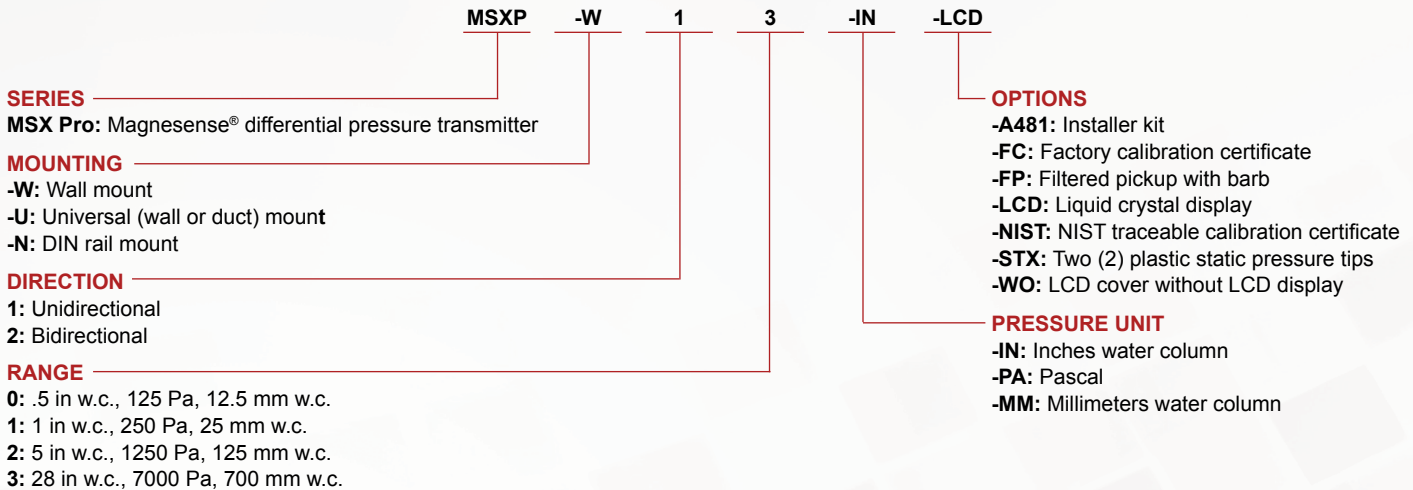

ACCESSORIES

Model	Description
A-480	Plastic static pressure tip
A-481	Installer kit, includes 2 plastic static pressure tips and 7 ft (2.1 m) of PVC tubing
A-MSXP-LCD	Replacement display for the Series MSX Pro

ORDER ONLINE TODAY!

dwyer-inst.com/Product/SeriesMSX



DWYER INSTRUMENTS, INC.