

## P32 Series Sensitive Differential Pressure Switch

### Application

This differential pressure switch is used to sense the flow of air in ducts. When used with electric strip heaters, the switch can be wired to open the control circuit and de-energize the heaters when air flow stops.

Typical applications include:

- air flow proving with electric duct heaters
- maximum air flow controller for variable air volume systems
- clogged filter detection
- detection of icing of air conditioning coils and initiation of defrost cycle

For a P32 sensitive differential pressure switch for combustion air applications, see instruction Form 996-434.

**IMPORTANT:** The Series P32 pressure switches are intended to control equipment under normal operating conditions. Where failure or malfunction of a P32 pressure switch could lead to an abnormal operating condition that could cause personal injury or damage to the equipment or other property, other devices (limit or safety controls) or systems (alarm or supervisory) intended to warn of or protect against failure or malfunction of the P32 pressure switch must be incorporated into and maintained as part of the control system.

### Operation

This differential pressure switch senses a change in the differential pressure (either velocity pressure or pressure drop across a fixed restriction in the duct) as air flow in the duct changes. This differential pressure, as sensed by the two sensing ports, is applied to the two sides of a diaphragm in the pressure switch.

The spring-loaded diaphragm moves and actuates the switch when the air pressure difference reaches the setpoint.

This switch can also be used to detect small positive gauge pressure by using only the high pressure connection and leaving the low pressure connector open, or to detect a vacuum by using only the low pressure connection and leaving the high pressure connector open to ambient pressure.

### Installation

Follow equipment manufacturer's instructions.

### Locating

Select a location on or near the duct where vibrations are minimal and the terminal screws and adjusting screw are accessible. Ambient temperature should be within the range of -40 to 167°F (-40 to 75°C) to avoid physical damage to the control. The factory setting of the P32 is made at room temperature. Mounting locations should be as close to room temperature as possible.

Otherwise, for best performance, switches should be set in the field in their mounted position and at the normal ambient temperature for that application.



**Fig. 1 – P32AC Differential Pressure Switch with “U” mounting bracket and direct mounted sensing probe assembled.**

### Mounting

The switch is normally mounted with the diaphragm in a vertical position. It may be fastened directly to the duct, heater, or panel as long as the mounting surface has minimal or no vibration.

**Note:** The switch is factory set with the diaphragm in a vertical position. If it is mounted in a horizontal position with the steel housing (high pressure connector) down, the setpoint will increase by about 0.07 in W.C. (.017 kPa). If mounted with the steel housing up, the switch may be inoperative at minimum setting. Adjustable models can be readjusted for this mounting position and minimum setpoint as follows:

1. Mount the switch securely.
2. Make sure no pressure is applied to either connector.
3. Turn the adjusting screw clockwise until the switch operates and at least an additional 1/3 turn.

**IMPORTANT:** When turning the fitting into the plastic low pressure port, do not overtighten and crack the threaded boss. Turn fitting in finger-tight, then an additional 1 to 1 1/2 turns (approximately 15 to 20 in.-lb). Sealing compound or tape is not required for the plastic low pressure port.

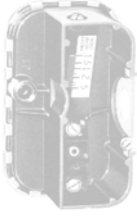

**Fig. 2 – Interior view of the P32AA Differential Pressure Switch.**

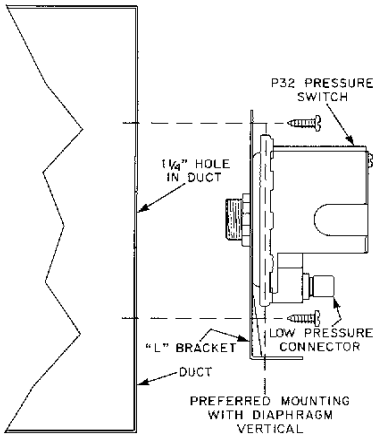

**Fig. 3 – Direct mounting a P32 using the “L” bracket as a mounting flange.**

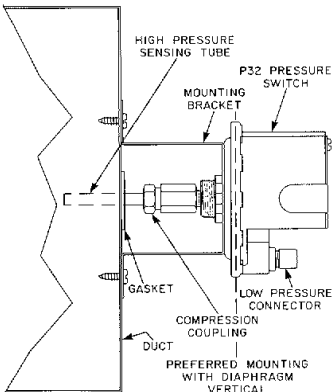

**Fig. 4 – Typical installation for a P32 Switch on duct using Part No. BKT229-1R bracket and direct mounting probe.**

**For direct duct or heater mounting**

1. Cut or drill a 7/8 in. (22 mm) diameter hole.
2. Install tubing in the 1/8 in. NPT high pressure (metal) connector, if required.
3. Place the metal connector in the hole.
4. Use a 1/2 in. conduit lock nut on the connector and secure in place.

**For direct duct mounting with “L” bracket No. BKT182-2R where inside of duct is not accessible for securing lock nut (See Fig. 3.)**

1. Cut or drill a 1-1/4 in. (32 mm) diameter hole in duct.
2. Secure mounting bracket to switch with angle at side of switch using 1/2 in. conduit lock nut.
3. Mount to duct using sheet metal screws through the four holes in large surface of mounting bracket.

**For direct mounting with channel “U” bracket No. BKT229-1R (See Fig. 4.)**

1. Drill a 1/4 in. (6 mm) hole in the duct at sensing location.
2. Install 1/4 in. tube into metal (high pressure) connector with compression fitting and coupling.
3. Secure bracket to switch with 1/2 in. conduit lock nut, if not factory installed.
4. Remove adhesive protection paper from gasket and slide gasket onto 1/4 in. tube with adhesive away from switch.
5. Place switch on duct tube in 1/4 in. hole, drill or punch mounting screw holes.
6. Fasten to duct with the two self-tapping screws.
7. Press gasket against duct.

**For remote mounting (See Fig. 5.)**

1. If direct panel mount is desired, drill 7/8 in. (22 mm) diameter hole and secure with lock nut.
2. When mounting bracket is required, use “L” bracket No. BKT182-2R.
3. Use the bracket as a guide and drill or punch the mounting screw holes.
4. Determine the correct mounting bracket position and secure it to the switch with 1/2 in. conduit lock nut. (There may be installations where the bracket must be installed before fastening it to the switch.)
5. Use FTG18A-600R remote mounting probe kits for remote sensing locations. Run plastic or copper tubing from the high and/or low pressure connectors to the sensing point. Use tubing with at least .170 in. I.D. (1/4 in. O.D.).

**Wiring**

**WARNING: Risk of electrical shock.**  
Disconnect the electrical power supply before wiring the switch into circuit to avoid electrical shock.

**CAUTION: Risk of equipment damage.**  
Disconnect the electrical power supply before wiring the switch into circuit to avoid possible damage to equipment.

Make all wiring connections using copper conductors only, and in accordance with the [local](#), [national](#), and [regional regulations](#).

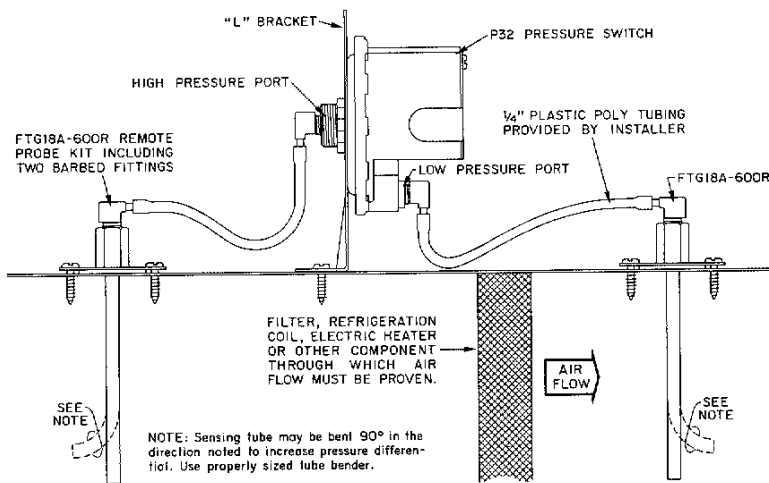

**Fig. 5 — The P32 may be mounted on either a vertical or horizontal surface using an "L" bracket and two FTG18A-600R remote mounted probe kits.**

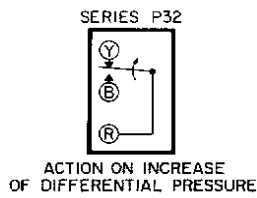

**Fig. 6 – Switch action on the P32 control**

**IMPORTANT:** Use terminal screws furnished (8-32 x 1/4 in. binder head). Substitution of other screws may cause problems in making proper connections.

The SPDT models have color coded terminals. The Red to Yellow circuit **closes** on differential pressure **increase** and the Red to Blue circuit **opens**. (See Fig. 6.)

## Adjustment

The field-adjustable switch has an adjusting screw located under the cover. Some models have a scale plate for adjusting convenience.

To adjust:

1. Remove cover.
2. Turn adjusting screw CW to increase the **differential pressure** setpoint.
3. Turn adjusting screw CCW to decrease the setpoint.
4. If the high or low adjustment stop is reached, **back off** the adjusting screw at least 1/6 turn from the stop.

## Checkout Procedure

Before leaving the installation, observe at least three complete operating cycles to ensure that all components function correctly.

## Repairs and Replacement

Field repairs must not be made. For a replacement pressure switch, contact the nearest Johnson Controls **distributor**.