

Danfoss



**Application Quick Guide
VLT® AQUA Drive FC 200**



Safety instructions

This Application Quick Guide is intended only for use by trained specialists in conjunction with the product manuals for working on VLT® AQUA Drive FC 200 series frequency converters.

Hazardous voltages are present in the frequency converter when it is connected to the mains. Incorrect installation of the motor, frequency converter or control cables can cause irreparable damage to the frequency converter or system as well as serious or fatal injuries.

To prevent electrical shock, the frequency converter must be disconnected from the mains before performing all maintenance work. The DC link capacitors of the VLT® AQUA Drive FC 200 retain their charge for a very long time even after disconnecting the mains supply. It is therefore essential to wait for the duration of the period specified on the unit or in the product manual before carrying out any maintenance work after disconnecting the mains supply.

Always follow the instructions contained in the relevant product manuals as well as local and national rules and safety regulations.



The contents of this Application Quick Guide refer mainly to the basic unit of the VLT® AQUA Drive with graphical control panel (LCP 102) up to 90 kW (400 V) and initial operation with an asynchronous motor. For the sake of clarity, this Application Quick Guide does not cover all options and accessories or detailed differences with higher-power models or special variants. Please refer to the corresponding product manual in all cases.

Table of contents

1. Connection

- 1.1 List of power and supply terminals
- 1.2 Control terminals in basic unit
(without A, B or C options)
- 1.3 Function of DIP switches in basic unit
(without A, B or C options)
- 1.4 Digital input programming options

2. Operation via LCP 102

- 2.1 Graphical control unit LCP 102
- 2.2 Explanation of LCP 102 status display

3. Easy commissioning

- 3.1 Commissioning menu (Q2 submenu of Quick menu)
- 3.2 Further commonly used parameters from the main menu
- 3.3 Transferring unit parameters using the LCP copy function
(Par. 0.50)
- 3.4 Parameter setting with MCT 10 software

4. Profibus DP interface

- 4.1 General settings
- 4.2 Further settings

5. Fault analysis

- 5.1 Warnings, alarms, and alarm resetting
- 5.2 If the drive fails to restart after
resetting an alarm
- 5.3 Warning and alarm indications

6. Application examples

- 6.1 Start/stop, four-pole motor, motor thermistor
- 6.2 Start/stop, four-pole motor, oversynchronous,
motor thermistor
- 6.3 Start/stop, two-pole motor, motor thermistor
- 6.4 Start/stop, two-pole motor, oversynchronous,
motor thermistor
- 6.5 Start/stop, motor thermistor
- 6.6 Fixed speeds
- 6.7 Automatic fast ramp
- 6.8 Manual/Off/Automatic selection with
reference value input via keypad
- 6.9 Manual/Off/Automatic selection with
reference value input via potentiometer
- 6.10 Manual Profibus time-out selection
- 6.11 Pressure control in %
- 6.12 Pressure control in Pa
- 6.13 Pressure control in bar with pipe compensation
- 6.14 Volume flow control in m³/h, feedback signal
output 0–20 mA
- 6.15 Volumetric flow control in m³/h, oversynchronous,
feedback signal output 0–20 mA
- 6.16 Pressure control in bar, basic cascade controller

Terminal no.	Description	Remarks
91 (L1), 92 (L2), 93 (L3)	Three-phase connection for mains supply	
95	PE conductor connection	Use minimum 10 mm ² . See note below.
96 (W), 97 (V), 98 (W)	Three-phase motor connection	See nameplate for nominal data
99	PE conductor connection	Equipotential bonding for motor
88 (-), 89 (+)	Capacitor-backed DC link circuit intended for coupling several drive axes	Note: maximum voltage 850–1000 V DC.
81 (-), 82 (+)	Optional brake resistor connection for increased dynamic braking	Note: maximum voltage 850–1000 V DC.
35 (-), 36 (+)	MCB 107 D option: connection for optional external 24 V power supply for control electronics (plug-and-socket connector).	Max. 24 V DC +/- 15% Max. Input current 2.2 A



As frequency converters can produce earth leakage currents greater than 3.5 mA due to their mode of operation, in accordance with EN 50178 an earth conductor with a cross-section of at least 10 mm² must be used or two separately installed earth conductors must be connected.

Warning

Terminals 88/89 for DC link coupling can only be used with special accessories and involve special safety considerations. See the Danfoss design documentation for additional information.

Using terminals 81 and 82 to increase dynamic braking is only possible with suitable and correctly dimensioned brake resistors and involves special safety considerations. See the Danfoss design documentation for additional information.

1.2 Control terminals in basic unit (without A, B or C options)

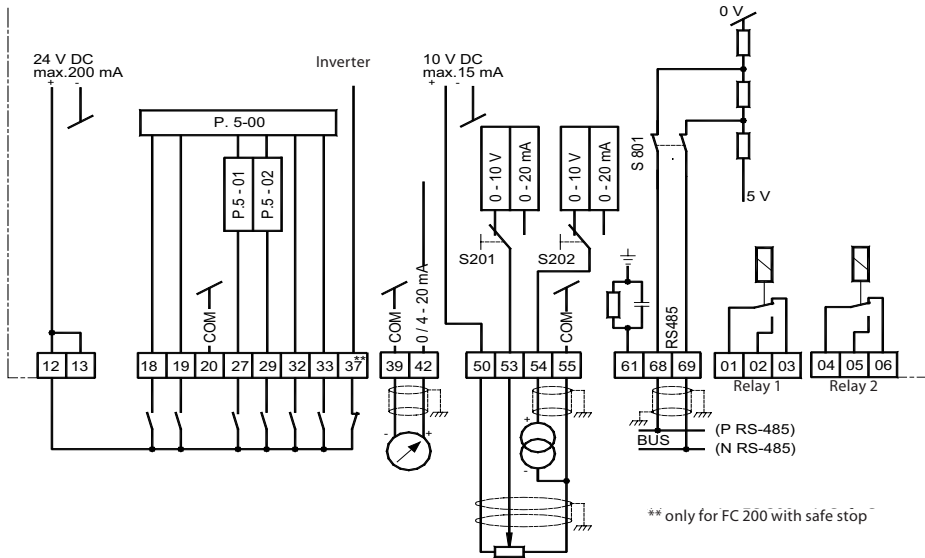

See Section 1.3 for a description of switches S201, S202 and S801.
The maximum rated voltage on analogue inputs 53 and 54 is 20 V.

Terminal no.	Description	Remarks
12, 13	Internal +24 V DC source for powering digital inputs.	Maximum load 200 mA
18	Digital input (see parameter 5-10 for function)	0–24 V DC, $R_i = 4 \text{ k}\Omega$ < 5 V = logic "0" (PNP logic)
19	Digital input (see parameter 5-11 for function)	> 10 V = logic "1" (PNP logic)
20	Reference potential (0 V) for external digital input/output configuration	Frame potential for terminals 12, 13
27	Digital input/output (see parameters 5-01, 5-12 & 5-30 for function)	Input: see terminals 18 and 19 Output: 0/24 V DC, max. 40 mA
29	Digital input/output (see parameters 5-02, 5-13 & 5-31 for function)	Pulse output: see product manual
32	Digital input (see parameter 5-14 for function)	Input: see terminals 18 and 19
33	Digital input (see parameter 5-15 for function)	Pulse input: see product guide
37	Only for FC 200 with optional safe stop Digital input for safe stop compliant with EN 954-1 Cat. 3 or EN 13849-1 SIL 2 (see parameter 5-19 for function)	To achieve the safety function, the information in the design guide must be observed.
39	Ground potential for analogue output 42	
42	Scalable analogue output 0/4–20 mA (see parameter 6.5* for function)	0/4–20 mA, 500 Ω max.
50	Internal +10 V DC power source, for example, for supplying potentiometer or motor thermistor	10 V DC, max. 15 mA
53, 54	Analogue inputs 0–10 V DC or 0/4–20 mA, selectable for reference/feedback or motor thermistor (function: terminal 53, see parameter 6-1*; terminal 54, see parameter 6-2*; reference, see parameters 3-15, 3-16 & 3-17; feedback, see parameter 20-0*; motor thermistor, see parameters 1-93 & 1-90)	0 to +10 V, scalable, R_i approx. 10 $\text{k}\Omega$; 0 to 20 mA, scalable, R_i approx. 200 Ω V/mA selection; see S201/S202 Note: maximum voltage on analogue inputs 20 V .
55	Ground potential for analogue inputs 53 and 54	
61	Integrated RC decoupling	Do not use
68 (+), 69 (-)	RS 485 serial interface (see parameter 8-3* for function)	Max. 115 kbit/s
01, 02, 03	Relay output 1 (see parameter 5-40 [0] for function)	Max. 240 V AC, 2 A (resistive load)
04, 05, 06	Relay output 2 (see parameter 5-40 [1] for function)	See the design guide for further information.

1.3 Function of DIP switches in basic unit (without A, B or C options)

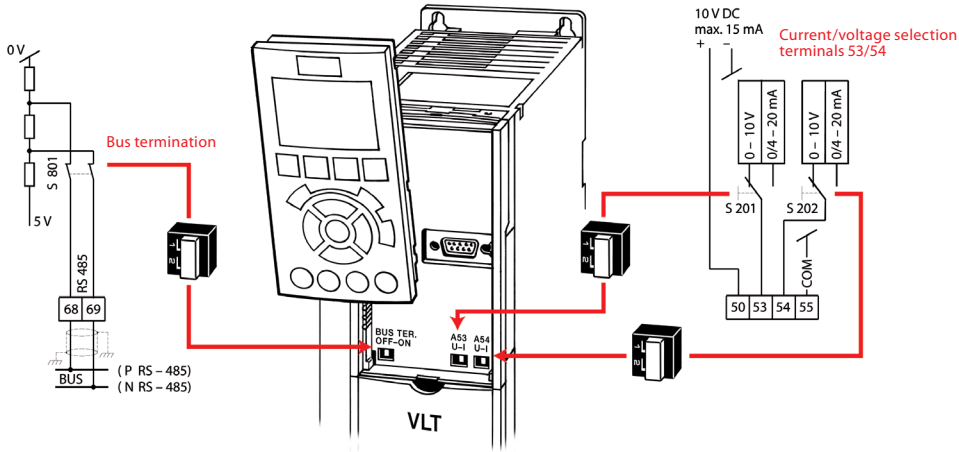

Changes to DIP switch settings become effective only after switching off and then on again.

1.4 Digital input programming options

Terminal no.	Index	18	19	27	29	32	33
Parameter		5-10	5-11	5-12	5-13	5-14	5-15
Not used	[0]	✓	✓	✓	✓	x	x
Alarm reset	[1]	✓	✓	✓	✓	✓	✓
Coast (inverse)	[2]	✓	✓	x	✓	✓	✓
Coast/Reset (inverse)	[3]	✓	✓	✓	✓	✓	✓
Quick stop ramp (inverse)	[4]	✓	✓	✓	✓	✓	✓
DC brake (inverse)	[5]	✓	✓	✓	✓	✓	✓
Stop (inverse)	[6]	✓	✓	✓	✓	✓	✓
Ext. interlock	[7]	✓	✓	✓	✓	✓	✓
Start	[8]	x	✓	✓	✓	✓	✓
Latched start pulse	[9]	✓	✓	✓	✓	✓	✓
Reversing	[10]	✓	x	✓	✓	✓	✓
Start + reversing	[11]	✓	✓	✓	✓	✓	✓
Fixed speed (jog)	[14]	✓	✓	✓	x	✓	✓
Fixed reference enabled	[15]	✓	✓	✓	✓	✓	✓
Fixed reference bit 0	[16]	✓	✓	✓	✓	✓	✓
Fixed reference bit 1	[17]	✓	✓	✓	✓	✓	✓
Fixed reference bit 2	[18]	✓	✓	✓	✓	✓	✓
Store reference	[19]	✓	✓	✓	✓	✓	✓
Store speed	[20]	✓	✓	✓	✓	✓	✓
Speed up	[21]	✓	✓	✓	✓	✓	✓
Speed down	[22]	✓	✓	✓	✓	✓	✓
Set-up select bit 0	[23]	✓	✓	✓	✓	✓	✓
Set-up select bit 1	[24]	✓	✓	✓	✓	✓	✓

Terminal no.	Index	18	19	27	29	32	33
Parameter		5-10	5-11	5-12	5-13	5-14	5-15
Counter input	[30]	-	-	-	✓	-	✓
Pulse input	[32]	-	-	-	✓	-	✓
Ramp bit 0	[34]	✓	✓	✓	✓	✓	✓
Mains failure (inverse)	[36]	✓	✓	✓	✓	✓	✓
Run Permissive	[52]	✓	✓	✓	✓	✓	✓
Manual Start	[53]	✓	✓	✓	✓	✓	✓
Auto start	[54]	✓	✓	✓	✓	✓	✓
DigiPot Increase	[55]	✓	✓	✓	✓	✓	✓
DigiPot Decrease	[56]	✓	✓	✓	✓	✓	✓
DigiPot Clear	[57]	✓	✓	✓	✓	✓	✓
Counter A (+1)	[60]	-	-	-	✓	-	✓
Counter A (-1)	[61]	-	-	-	✓	-	✓
Reset Counter A	[62]	✓	✓	✓	✓	✓	✓
Counter B (+1)	[63]	-	-	-	✓	-	✓
Counter B (-1)	[64]	-	-	-	✓	-	✓
Reset Counter B	[65]	✓	✓	✓	✓	✓	✓
Sleep Mode	[66]	✓	✓	✓	✓	✓	✓
Reset Maintenance Word	[78]	✓	✓	✓	✓	✓	✓
Lead Pump Start	[120]	✓	✓	✓	✓	✓	✓
Lead Pump Alternation	[121]	✓	✓	✓	✓	✓	✓
Pump 1 Interlock	[130]	✓	✓	✓	✓	✓	✓
Pump 2 Interlock	[131]	✓	✓	✓	✓	✓	✓
Pump 3 Interlock	[132]	✓	✓	✓	✓	✓	✓

✓] = selectable; [-] not selectable; [x] = factory setup. See programming manual for details.

2. Operation via LCP 102

2.1 Graphical control unit LCP 102

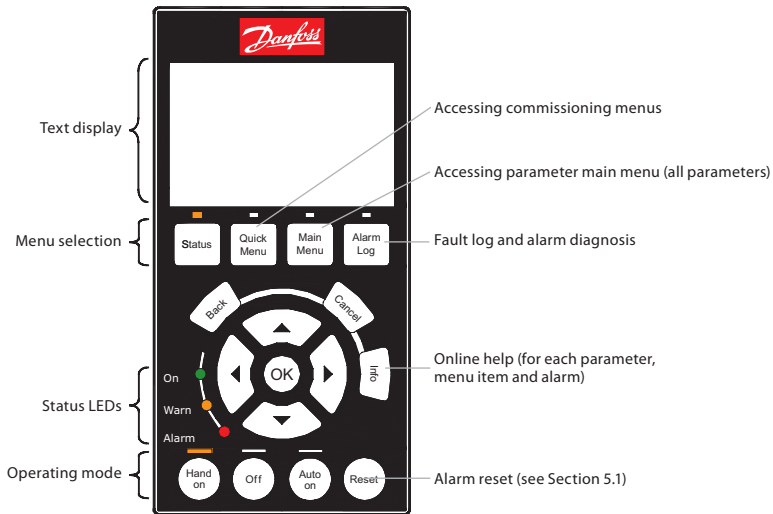

2.2 Explanation of LCP 102 status display

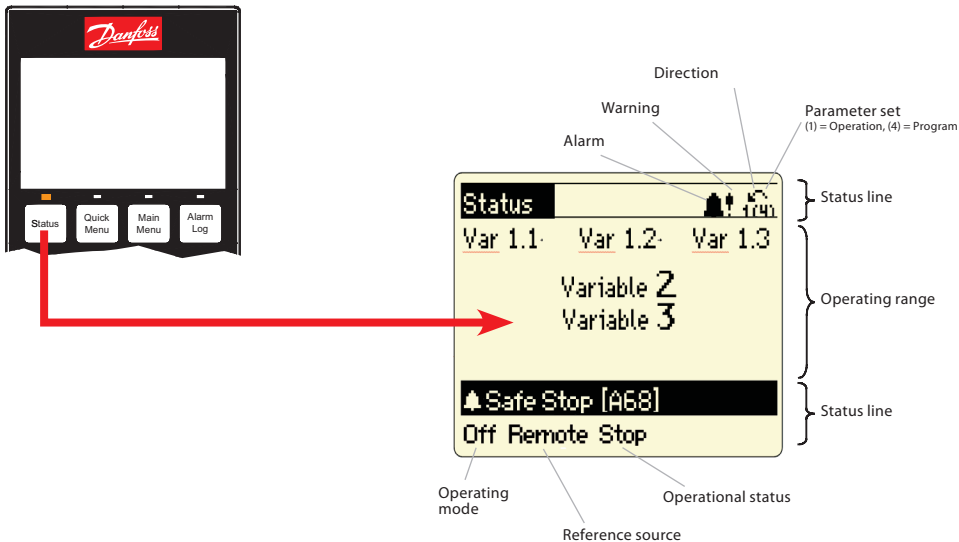

3. Easy commissioning

3.1 Commissioning menu (submenu Q2 of Quick Menu)

The commissioning menu has a set of 11 parameters that are necessary during typical commissioning. These parameters are arranged logically instead of by number. Note: always enter the parameters in the order shown. To access the commissioning menu, press the [Quick Menu] button, select „Q2 commissioning menu“, and confirm with [OK]. Press the [Status] button to return to normal view.

Par.	Description	Setting
0-01	Language	English [0] or set to local language
1-20	Motor power [kW]	According to motor nameplate data
1-22	Motor voltage [V]	According to motor nameplate data
1-23	Motor frequency [Hz]	According to motor nameplate data
1-24	Motor current [A]	According to motor nameplate data
1-25	Rated motor speed [rpm]	According to motor nameplate data
3-41	Ramp-up time 1	Set ramp-up time (acceleration time up to rated motor speed)
3-42	Ramp-down time 1	Set ramp-down time (deceleration time from rated speed to zero RPM)
4-12	Min. speed [RPM]	Set desired minimum speed
4-14	Max. speed [RPM]	Set desired maximum speed
1-29	Automatic Motor Adaptation (AMA)	AMA is worthwhile if motor operation is unsatisfactory or additional optimisation is desired. See the description of AMA in the product guide.

3.2 Other commonly used parameters in the main menu

The following table lists other parameters in the main menu that are often necessary in addition to the commissioning parameters. The parameters in the main menu can be accessed by pressing the [Main Menu] button and selecting the subgroups.

Par.	Description	Setting
1-00	Control response	Speed control or PID control
1-03	Load torque characteristics	[0] compressor torque, [1] square-law torque, [2] automatic energy optimisation CT, [3] automatic energy optimisation VT
1-9*	Thermal motor protection	Motor temperature monitoring, see description under 6. Application examples:
3-10	Fixed references (0–7)	Use digital fixed references
3-15	Variable reference 1	Select an analogue input, digital input or bus port as the reference signal. See also description under 6. Application examples:
3-16	Variable reference 2	
3-17	Variable reference 3	
6-1*	Analogue input, terminal 53	Input signal scaling (current/voltage) and the associated reference and feedback values.
6-2*	Analogue input, terminal 54	Input signal scaling (current/voltage) and associated reference and feedback values.
20-0*	Feedback	Specify feedback inputs and signal characteristic
20-2*	Feedback/reference	Specify signal conditioning here when using several feedback values and/or additional reference values.
15-0*	Operating data	Display of current operating data
15-3*	Fault log	Read out fault log data and values
15-4*	Type data	15-43/-45/-51: frequency converter identification. This information is necessary for service queries.
14-50	RFI filter	Must be disabled if the unit is used in an IT network.
16-**	Data display	of all current frequency converter and system data (such as reference, feedback, bus, motor, and FC data)

3.3 Using the LCP copy function (parameter 0-50) to transfer device parameters

The copy function can be used to store all unit parameters in the LCP 102 control panel. The stored parameters can be transferred to the same unit of other units if necessary. The data is permanently stored (in EEPROM) in the LCP and can only be changed or deleted by overwriting with new data. The parameters in the LCP memory can only be accessed by loading them back from the unit. Parameter 0-50 can be accessed by pressing the [Main Menu] button and selecting menu „0-** Operation/Display“ or „0-5* Copy/Store“.

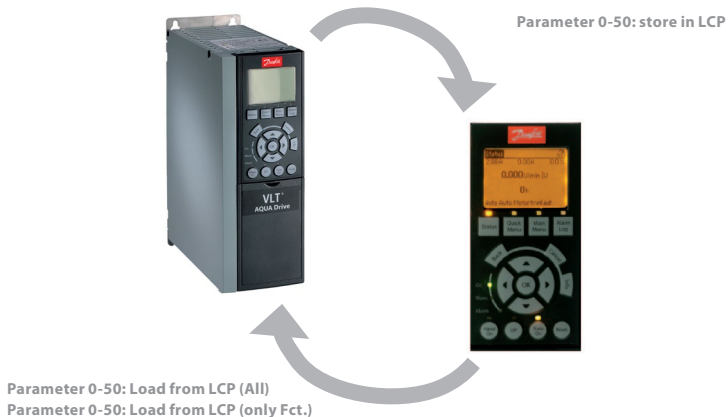

No motor data is transferred if „Load from LCP, only Fct.“ is selected.

3.4 Parameter setting with MCT 10 software

Source and system requirements

Download the software from the Software/MCT 10 Software page at www.danfoss.com/drives

The free basic version of the MCT 10 software can be used to archive data from and document all current Danfoss frequency converter series. The CD key required for installation is 12314500.

Minimum system requirements: Pentium III 350 MHz (or compatible), 128 MB RAM, 200 MB free hard drive space.

Data exchange with the converter

- Converter -> PC:
1. Connect the converter to the PC
 2. Select the converter in the network
 3. Select „Copy“
 4. Click the project and select „Add“
 5. Save the project in the File menu

- PC -> Converter:
1. Open the saved file
 2. Connect the converter to the PC
 3. Select the converter in the project
 4. Select „Write to frequency converter“

Access via USB port

The connection between the converter and PC is detected automatically. Configuration of the parameters in the converter or the PC software is not necessary.

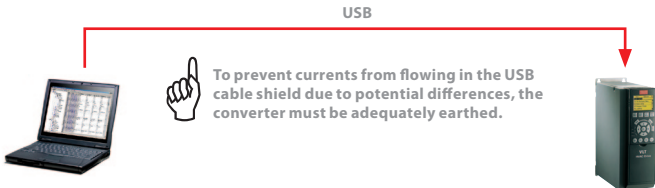

Access via RS-232, Ethernet, or USB Converter

Every Danfoss converter has a bus-capable RS-485 interface. It supports up to 32 network nodes (127 with repeaters). For access to the interface, a suitable converter (RS-232 to RS-485, USB to RS-485, or Ethernet TCP/IP to RS-485) is necessary.



Connection

How to connect  Terminal 68: P (RS-485)
Terminal 69: N (RS-485)

Par.	Description	Factory setup
8-31	Address	1
8-32	Baud rate	9600 baud

In order to use the connection and configure the converter, the interface settings of the MCT 10 software (Communication -> Driver menu) must be compatible (address range, COM port and baud rate). You can use the Communication -> Network Search menu item to look for connected converters.

4. Profibus DP interface

4.1 General settings

Parameter	Description	Setting
8 - 10	Control Word Profile	See PLC
9 - 18	Profibus node address (set all address DIP switches to „ON“)	0-125
9 - 22	PPO type	Automatic
9 - 63	Baud rate	Automatic



The settings do not take effect until the Profibus interface has been initialised (use parameter 9-72 to reset the interface or switch the external 24 V supply off and back on).

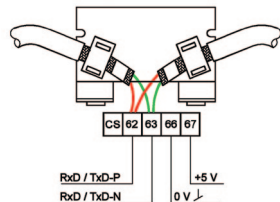

4.2 Further settings

Parameter	Description	Setting
8 - 01	Control Site	Activate control word
8 - 02	Active control word	Option A
8 - 50 ... 8 - 56	Priorities between bus/terminal operation (observe parameter 8-01)	Application dependent
8 - 03 ... 8 - 05	Control word timeout (defined response to bus failure)	Application dependent
8 - 07	Diagnosis Trigger (disable in case of doubt)	See PLC
9 - 15 ... 9 - 16	PCD Configuration	See PLC
9 - 27 ... 9 - 28	PCW/PCD enabled/disabled	Enabled

5. Fault analysis

5.1 Warnings, alarms, and alarm resetting

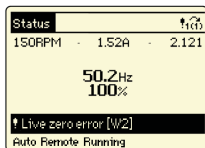

Warning (yellow Warning LED on)

A warning is an indication of a defined state. Warning indications can occur during normal operation; they may be purely informative (uncritical) or indicate a potential problem. Analyse the warning based on the displayed warning number [Wxxx].

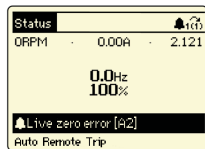

Alarm (red Alarm LED blinks)

Alarm indications occur when motor operation has been inhibited by the FC 200 for safety reasons. Analyse the alarm based on the displayed alarm number [Axxx]. There are several ways to reset alarms that are „trip-locked“ after the cause has been remedied:

- [Reset] button on LCP
- Programmed digital input (see parameter settings in group 5-1*)
- Automatic reset function (see parameter settings in group 14-2*)
- Reset signal via bus interface (such as RS-485 or Profibus)



The reset signal resets the frequency converter after an alarm (trip). The button can be enabled [1] or disabled [0] with parameter 0-43, "LCP Reset button".

Warning

Before resetting an alarm, always determine and remedy the cause. Resetting an alarm without adequately determining the cause can lead to damage to the frequency converter or system as well as serious accidents.

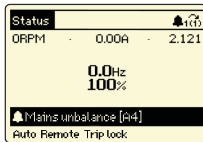

Trip-locked alarm (red Alarm LED blinks, alarm cannot be reset, and „Trip-lock“ is displayed on the control panel (if present))

Trip-lock is an additional protective function of the VLT® AQUA Drive and can only be cancelled by disconnecting mains power to the unit. If the unit has an external 24 V DC supply (D option), it is only necessary to disconnect the unit from the mains supply voltage. In this case, the control card remains active (for example, to support fieldbus communication).

The alarm can be reset again as previously described after the VLT® AQUA Drive FC 200 has been switched off and on.

If the display still shows a trip-lock after the unit has been switched off (before the alarm is reset), the unit may have an internal fault. Contact your Danfoss Service provider in this case.

5.2 If the drive does not restart after an alarm reset

	An alarm is still displayed	Setting
1.	Is the alarm trip-locked?	See description in Section 5.1.
2.	Has the cause of the alarm been remedied, or is the alarm displayed again immediately after it is reset?	View the alarm numbers in the fault/alarm log and use them to determine the cause of the alarm.
3.	Is the LCP [Reset] button enabled?	See parameter 0-43

	An alarm is no longer displayed	Setting
1.	Is the LCP [Off] button enabled?	Press the [Auto-On] button to restart.
2.	Is a start signal present on the digital input or bus interface?	Check whether a start signal is present on the digital input or the bus.
3.	Is a reference value available on an analogue or digital input or the bus interface?	Check the reference value.
4.	Is there an open circuit between the frequency converter output and the motor?	Check the motor wiring. Is a contactor or motor switch present?

5.3 Warning and alarm indications

No.	Description	Warning	Alarm / trip	Alarm / Trip-lock	See parameter
1	10 V low	X			
2	Signal fault	(X)	(X)		6-01
3	No motor	(X)			1-80
4	Mains phase imbalance	(X)	(X)	(X)	14-12
5	DC link voltage high	X			
6	DC link voltage low	X			
7	DC overvoltage	X	X		
8	DC undervoltage	X	X		
9	Inverter overloaded	X	X		
10	Motor ETR overtemperature	(X)	(X)		1-90
11	Motor thermistor	(X)	(X)		1-90
12	Torque limit	X	(X)		14-25
13	Overcurrent	X	X	X	
14	Earth fault	X	X	X	
15	Hardware mismatch		X	X	
16	Short circuit		X	X	
17	Control word time-out	(X)	(X)		8-04
23	Internal fan fault	(X)	(X)		14-53
24	External fan fault	(X)	(X)		14-53
25	Brake resistor shorted	X			
26	Brake resistor power limit	(X)	(X)		2-13
27	Brake chopper shorted	X	X		
28	Brake resistor test	(X)	(X)		2-15

29	Inverter overtemperature	X	X	X	
30	Motor phase U dropout	(X)	(X)	(X)	4-58
31	Motor phase V dropout	(X)	(X)	(X)	4-58
32	Motor phase W dropout	(X)	(X)	(X)	4-58
33	Inrush fault		X	X	
34	Fieldbus fault	X	(X)		
36	Mains failure	X	X		
38	Internal fault		X	X	
40	Overload digital output 27	X			5-00, 5-01
41	Overload digital output 29	X			5-00, 5-02
42	Overload on digital output 30-6/30-7	X			
47	24 V supply low	X	X	X	
48	1.8 V supply low		X	X	
49	Speed limit	X			
50	AMA calibration fault		X		
51	AMA check Unom and Inom		X		
52	AMA low Inom		X		
53	AMA motor too big		X		
54	AMA motor too small		X		
55	AMA parameter out of range		X		
56	AMA interrupted by user		X		
57	AMA timeout		X		
58	AMA internal fault	X	X		

59	Current limit	X			
60	Ext. interlock	(X)			5-1*
62	Output frequency limit	X			4-19
64	Motor voltage	X			
65	Control board overtemperature	X	X	X	
66	Temperature low	X			
67	New options		X		
68	Safe stop		X		
69	Inverter overtemperature		X	X	
70	Invalid FC configuration		X	X	
79	Invalid PS configuration	X	X		
80	Unit initialised		X		
92	K. flow	X	X		22-23
93	Dry pump	X	X		22-26
94	End of curve	X	X		22-50
95	Broken belt	X	X		22-60
96	Start delay	X			22-75, 22-76
97	Stop delay	X			22-75, 22-77
98	Clock fault	X			0-7*
250	New spare part				
251	New type code				

(X) Dependent on parameter

6. Application Examples

6.1 Start/stop, four-pole motor, motor thermistor

Reference 0–50 Hz via terminal 53; motor thermistor monitoring on terminal 19.

Visual alarm indication.

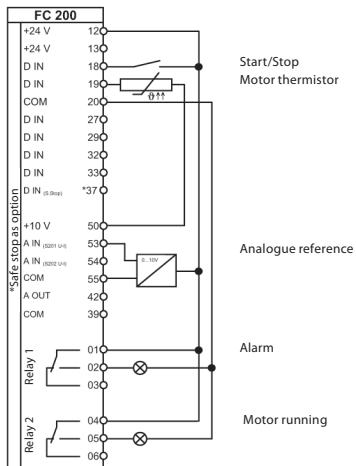

This example constitutes a non-binding recommendation with regard to the General Delivery and Warranty Conditions. It is based on the factory setup and presumes that the motor data has been configured correctly. This recommendation must be verified by the user.

Relevant parameters		
Par.	Function	Setting
0-02	Hz/rpm selection	[1] Hz
1-25	Rated motor speed	see motor nameplate
5-10	Terminal 18: digital input	[8] Start*
5-11	Terminal 19: digital input	[0] Not used
5-12	Terminal 27: digital input	[0] Not used
1-90	Motor thermal protection	[2] Thermistor trip
1-93	Thermistor connection	[4] Digital input 19
3-15	Variable reference 1	[1] Analogue input 53*
4-53	High speed warning	1500 rpm
5-40 [0]	Relay 1 function	[9] Alarm
5-40 [1]	Relay 2 function	[5] Motor running
* Factory setting		

6.2 Start/stop, four-pole motor, oversynchronous, motor thermistor

0–72 Hz reference value via terminal 53.

Motor thermistor monitoring on terminal 19.

Visual alarm indication.

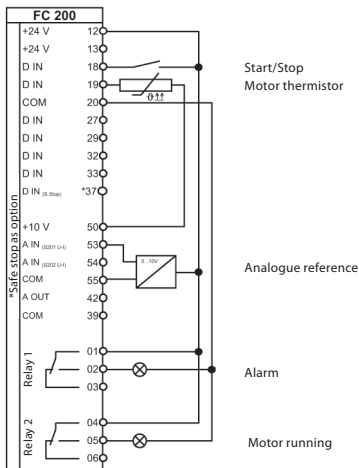

This example constitutes a non-binding recommendation with regard to the General Delivery and Warranty Conditions. It is based on the factory setup and presumes that the motor data has been configured correctly. This recommendation must be verified by the user.

Relevant parameters		
Par.	Function	Setting
0-02	Hz/rpm selection	[1] Hz
1-25	Rated motor speed	see motor nameplate
5-10	Terminal 18: digital input	[8] Start*
5-11	Terminal 19: digital input	[0] Not used
5-12	Terminal 27: digital input	[0] Not used
1-90	Motor thermal protection	[2] Thermistor trip
1-93	Thermistor connection	[4] Digital input 19
3-03	Max. reference	72 Hz
3-15	Variable reference 1	[1] Analogue input 53*
4-14	Max. frequency [Hz]	72 Hz
4-53	High speed warning	2045 rpm
6-15	Ter. 53 scale max. ref/feedback	72 Hz
5-40[0]	Relay 1 function	[9] Alarm
5-40[1]	Relay 2 function	[5] Motor running

* Factory setting

6.3 Start/stop, two-pole motor, motor thermistor

Reference 0–50 Hz via potentiometer on terminal 53.

Motor thermistor monitoring on terminal 19.

Visual alarm indication.

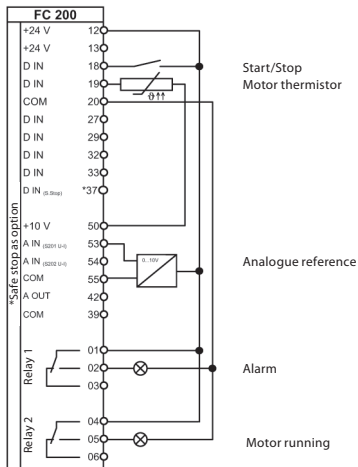

This example constitutes a non-binding recommendation with regard to the General Delivery and Warranty Conditions. It is based on the factory setup and presumes that the motor data has been configured correctly. This recommendation must be verified by the user.

Relevant parameters		
Par.	Function	Setting
0-02	Hz/rpm selection	[1] Hz
1-25	Rated motor speed	see motor nameplate
5-10	Terminal 18: digital input	[8] Start*
5-11	Terminal 19: digital input	[0] Not used
5-12	Terminal 27: digital input	[0] Not used
1-90	Motor thermal protection	[2] Thermistor trip
1-93	Thermistor connection	[4] Digital input 19
3-15	Variable reference 1	[1] Analogue input 53*
4-53	High speed warning	3000
5-40 [0]	Relay 1 function	[9] Alarm
5-40 [1]	Relay 2 function	[5] Motor running
* Factory setting		

6.4 Start/stop, two-pole motor, oversynchronous, motor thermistor

0–72 Hz reference value via terminal 53.

Motor thermistor monitoring on terminal 19.

Visual alarm indication.

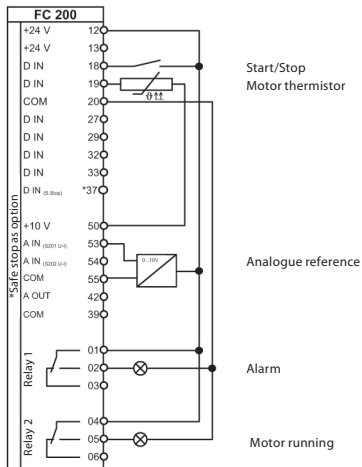

This example constitutes a non-binding recommendation with regard to the General Delivery and Warranty Conditions. It is based on the factory setup and presumes that the motor data has been configured correctly. This recommendation must be verified by the user.

Relevant parameters		
Par.	Function	Setting
0-02	Hz/rpm selection	[1] Hz
1-25	Rated motor speed	see motor nameplate
5-10	Terminal 18: digital input	[8] Start*
5-11	Terminal 19: digital input	[0] Not used
5-12	Terminal 27: digital input	[0] Not used
1-90	Motor thermal protection	[2] Thermistor trip
1-93	Thermistor connection	[4] Digital input 19
3-03	Max. reference	72 Hz
3-15	Variable reference 1	[1] Analogue input 53*
4-14	Max. frequency [Hz]	72 Hz
4-53	High speed warning	4320 rpm
6-15	Ter. 53 scale max. ref/feedback	72 Hz
5-40 [0]	Relay 1 function	[9] Alarm
5-40 [1]	Relay 2 function	[5] Motor running
* Factory setting		

6.5 Start/stop, motor thermistor

Reference 0–50 Hz terminal 53.

Motor thermistor monitoring on terminal 19.

Visual alarm indication.

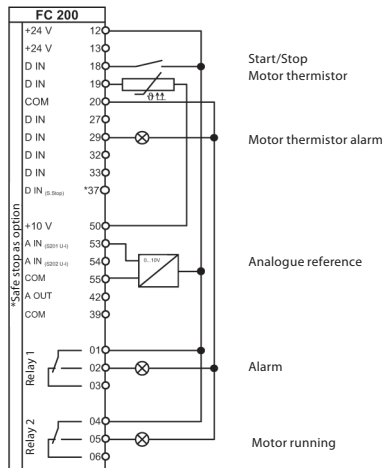

This example constitutes a non-binding recommendation with regard to the General Delivery and Warranty Conditions. It is based on the factory setup and presumes that the motor data has been configured correctly. This recommendation must be verified by the user.

Relevant parameters		
Par.	Function	Setting
5-10	Terminal 18: digital input	[8] Start*
5-11	Terminal 19: digital input	[0] Not used
5-12	Terminal 27: digital input	[0] Not used
5-02	Terminal 29 Mode	[1] Output
5-31	Terminal 29: digital output	[60] Comparator 0
1-90	Motor thermal protection	[2] Thermistor trip
1-93	Thermistor connection	[4] Digital input 19
3-15	Variable reference 1	[1] Analogue input 53*
5-40 [0]	Relay 1 function	[9] Alarm
5-40 [1]	Relay 2 function	[5] Motor running
Interrogation Alarm 11 (motor thermistor)		
13-10[0]	Comparator operand	[20] Alarm number
13-11[0]	Comparator function	[1] !(equal)*
13-12[0]	Comparator value	11,000
* Factory setting		

6.6 Fixed speeds

Three different speeds (preset references) can be selected via floating contacts.

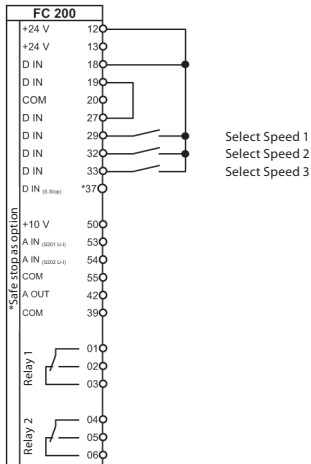

Relevant parameters		
Par.	Function	Setting
0-02	Hz/rpm selection	[1] Hz
5-10	Terminal 18: digital input	[8] Start*
5-11	Terminal 19: digital input	[6] Stop (inverse)
5-01	Terminal 27 Mode	[1] Output
5-30	Terminal 27: digital output	[70] Logic rule 0
5-13	Terminal 29: digital input	[16] Preset ref. bit 0
5-14	Terminal 32: digital input	[17] Preset ref. bit 1
5-15	Terminal 33: digital input	[18] Preset ref. bit 2
Internal logic rule		
13-40[0]	Boolean 1	[36] Digital input 29
13-41[0]	Logic operation 1	[2] OR
13-42[0]	Boolean 2	[37] Digital input 32
13-43[0]	Logic operation 2	[2] OR
13-44[0]	Boolean 3	[37] Digital input 33
References		
3-10[1]	Preset ref. 1	Desired Speed 1
3-10[2]	Preset ref. 2	Desired Speed 2
3-10[4]	Preset ref. 4	Desired Speed 3
* Factory setting		

This example constitutes a non-binding recommendation with regard to the General Delivery and Warranty Conditions. It is based on the factory setup and presumes that the motor data has been configured correctly. This recommendation must be verified by the user.

6.7 Automatic fast ramp

The starts up with fast acceleration and then runs with slow acceleration. Reference 0–1500 rpm via potentiometer.

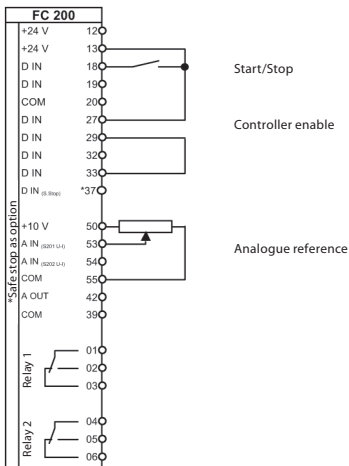

This example constitutes a non-binding recommendation with regard to the General Delivery and Warranty Conditions. It is based on the factory setup and presumes that the motor data has been configured correctly. This recommendation must be verified by the user.

Relevant parameters		
Par.	Function	Setting
5-10	Terminal 18: digital input	[8] Start*
5-11	Terminal 19: digital input	[0] Not used
5-12	Terminal 27: digital input	[2] Coast (inverse)*
5-02	Terminal 29 mode	[1] Output
5-31	Terminal 29: digital output	[16] Under min. speed
5-15	Terminal 33: digital input	[34] Ramp bit 0
3-15	Variable reference 1	[1] Analogue input 53*
3-41	Ramp Up 1	„Slow“
3-42	Ramp Down 1	„Slow“
3-51	Ramp Up 2	„Fast“
3-52	Ramp Down 2	„Fast“
4-11	Motor speed low limit	900 rpm
4-52	Motor speed low limit warning	900 rpm
* Factory setting		

6.8 Manual/Off/Automatic selection with reference value input via keypad

In the switch position „Auto“, the reference is active via potentiometer.

In the switch position „Manual“, the reference can be set using the „Up“ and „Down“ buttons.

In the switch position „Off“, the motor is stopped.

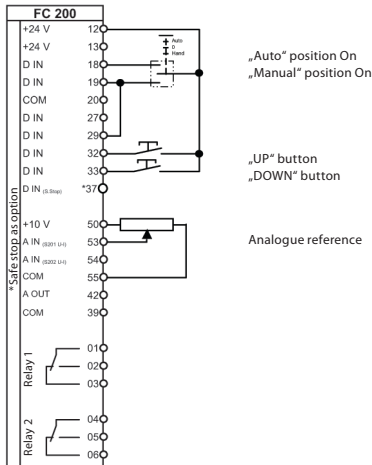

„Auto“ position On
„Manual“ position On

„UP“ button
„DOWN“ button

Analogue reference

Relevant parameters		
Par.	Function	Setting
5-10	Terminal 18: digital input	[8] Start*
5-11	Terminal 19: digital input	[8] Start
5-12	Terminal 27: digital input	[0] Not used
5-13	Terminal 29: digital input	[20] Freeze output
5-14	Terminal 32: digital input	[21] Speed up
5-15	Terminal 33: digital input	[22] Speed down
3-15	Variable reference 1	[1] Analogue input 53*
* Factory setting		

This example constitutes a non-binding recommendation with regard to the General Delivery and Warranty Conditions. It is based on the factory setup and presumes that the motor data has been configured correctly. This recommendation must be verified by the user.

6.9 Manual/Off/Automatic selection with reference value input via potentiometer

In switch position „Auto“, the reference is active via potentiometer.

In switch position „Manual“, the unit can only be operated via the display.

In switch position „Off“, the motor is stopped.

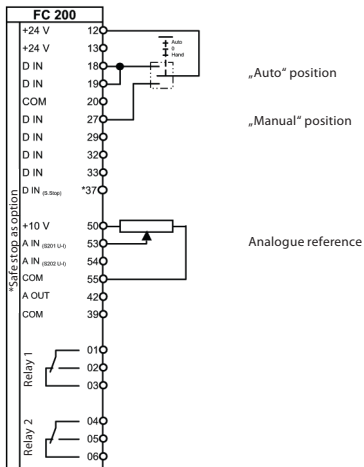

This example constitutes a non-binding recommendation with regard to the General Delivery and Warranty Conditions. It is based on the factory setup and presumes that the motor data has been configured correctly. This recommendation must be verified by the user.

Relevant parameters		
Par.	Function	Setting
5-10	Terminal 18: digital input	[8] Start*
5-11	Terminal 19: digital input	[54] Auto start
5-12	Terminal 27: digital input	[53] Manual start
3-15	Variable reference 1	[1] Analogue input 53*
* Factory setting		

6.10 Manual Profibus time-out selection

With Profibus control, the converter does not accept any commands via the terminals. If Profibus control is interrupted, the converter automatically switches to manual mode (reference setting via buttons). Manual mode can also be selected via terminal 18.

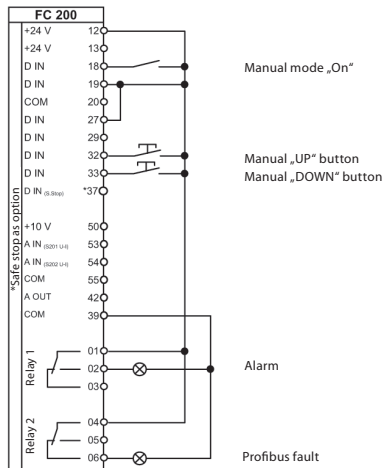

This example constitutes a non-binding recommendation with regard to the General Delivery and Warranty Conditions. It is based on the factory setup and presumes that the motor data has been configured correctly. This recommendation must be verified by the user.

Relevant parameters		
Par.	Function	Setting
1-1*	Motor data	see motor nameplate
8-03	Ctrl. param. for timeout time	1 sec
8-04	Timeout function ctrl. param.	[8] Select Setup 2
8-05	Timeout End ctrl. param.	[1] Resume setup*
9-18	Node address	As required
Data for both setups		
5-10	Terminal 18: digital input	[23] Setup select bit 0
5-40[0]	Relay function	[9] Alarm
5-40[1]	Relay function	[23] Bus OK
Setup selection		
0-51	Setup copy	[2] Copy to Setup 2
0-10	Active setup	[9] Multi Setup
0-12	Link setup to	[2] Setup 2
Settings only for Setup 1		
5-11	Terminal 19: digital input	[0] Not used
5-12	Terminal 27: digital input	[0] Not used
5-14	Terminal 32: digital input	[0] Not used
5-15	Terminal 33: digital input	[0] Not used
8-01	Control Site	Digital only
8-02	Active control parameter	Disabled
Settings only for Setup 2		
5-11	Terminal 19: digital input	[8] Start
5-12	Terminal 27: digital input	[20] Freeze output
5-14	Terminal 32: digital input	[21] Speed up
5-15	Terminal 33: digital input	[22] Speed down
8-01	Control Site	Digital only
8-02	Active control parameter	Disabled
* Factory setting		

6.11 Pressure control in %

Pressure control with integrated process controller.
Internal reference, feedback 0–100% on terminal 54.

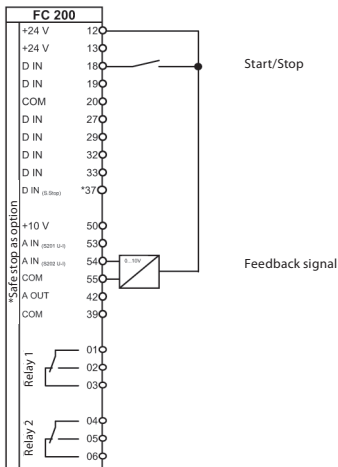

This example constitutes a non-binding recommendation with regard to the General Delivery and Warranty Conditions. It is based on the factory setup and presumes that the motor data has been configured correctly. This recommendation must be verified by the user.

Relevant parameters		
Par.	Function	Setting
Start/Stop		
5-10	Terminal 18: digital input	[8] Start*
5-12	Terminal 27: digital input	[0] Not used
Pressure control		
1-00	Control mode	[3] PID closed loop
20-12	Reference/feedback unit	[1] %*
20-21	Reference 1	50%
20-94	PID integration time	0.8
Feedback signal		
20-00	Feedback terminal 1	[2] Analogue input 54*
6-24	Ter. 54 scale min. ref/feedback	0%*
6-25	Ter. 54 scale max. ref/feedback	100%*
Display indication (optional)		
0-20	Display line 1.1	[1601] Reference [unit]
0-22	Display line 1.3	[1652] Feedback [unit]
* Factory setting		

6.12 Pressure control in Pa

Pressure control with integrated process controller.
Internal reference, feedback 0–2000 Pa on terminal 54.

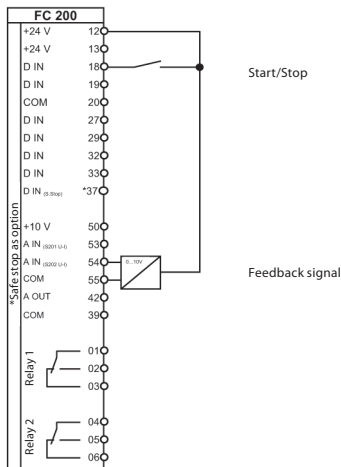

This example constitutes a non-binding recommendation with regard to the General Delivery and Warranty Conditions. It is based on the factory setup and presumes that the motor data has been configured correctly. This recommendation must be verified by the user.

Relevant parameters		
Par.	Function	Setting
Start/Stop		
5-10	Terminal 18: digital input	[8] Start*
5-12	Terminal 27: digital input	[0] Not used
Pressure control		
1-00	Control mode	[3] PID closed loop
20-12	Reference/feedback unit	[72] Pa
20-21	Reference 1	1500 Pa
20-94	PID integration time	0.8
Scaling in Pa		
3-02	Min. reference	0 Pa*
3-03	Max. reference	2000 Pa
Feedback signal		
20-00	Feedback terminal 1	[2] Analogue input 54*
6-24	Ter. 54 scale min. ref/feedback	0 Pa*
6-25	Ter. 54 scale max. ref/feedback	2000 Pa
Display indication (optional)		
0-20	Display line 1.1	[1601] Reference [unit]
0-22	Display line 1.3	[1652] Feedback [unit]
* Factory setting		

6.13 Pressure control in bar with pipe compensation

Pressure control using integrated process controller with pipe pressure drop compensation. Internal reference, feedback 0–10 bar on terminal 54.

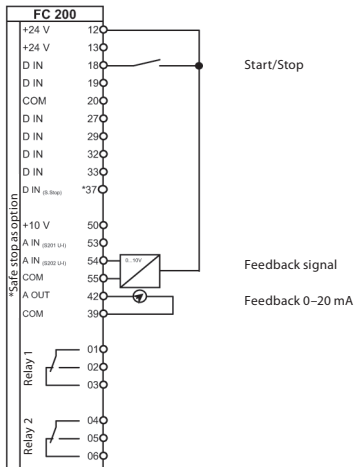

This example constitutes a non-binding recommendation with regard to the General Delivery and Warranty Conditions. It is based on the factory setup and presumes that the motor data has been configured correctly. This recommendation must be verified by the user.

Relevant parameters		
Par.	Function	Setting
0-02	Hz/rpm selection	[1] Hz*
Start/Stop		
5-10	Terminal 18: digital input	[8] Start*
5-12	Terminal 27: digital input	[0] Not used
Pressure control		
1-00	Control mode	[3] PID closed loop
20-12	Reference/feedback unit	[71] bar
20-21	Reference 1	5 bar
20-93	PID proportional gain	0.5
20-94	PID integration time	0.8
Scaling in bar		
3-02	Min. reference	0 bar*
3-03	Max. reference	10 bar
Feedback signal		
20-00	Feedback terminal 1	[2] Analogue input 54*
6-24	Ter. 54 scale min. ref/feedback	0 bar*
6-25	Ter. 54 scale max. ref/feedback	10 bar
Pipe compensation		
22-80	Flow compensation	[1] Enabled
22-81	Quad./lin. curve calculation	100
22-84	Speed at no flow [Hz]	25 Hz
22-86	Freq. design point [Hz]	50 Hz
22-87	Pressure at no-flow speed	3 bar
Display indication (optional)		
0-20	Display line 1.1	[1601] Reference [unit]
0-22	Display line 1.3	[1652] Feedback [unit]
0-24	Display line 3	[1665] Analogue output 42
* Factory setting		

6.14 Volume flow control in m³/h, feedback signal output 0–20 mA

Volume flow control with integrated process controller.

Internal reference, feedback 0–5000 m³/h on terminal 54.

Feedback output 0–5000 m³/h as 0–20 mA signal on terminal 42.

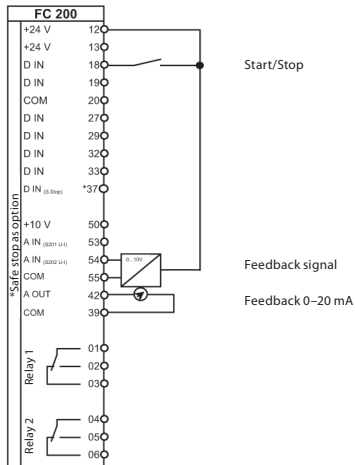

This example constitutes a non-binding recommendation with regard to the General Delivery and Warranty Conditions. It is based on the factory setup and presumes that the motor data has been configured correctly. This recommendation must be verified by the user.

Relevant parameters		
Par.	Function	Setting
Start/Stop		
5-10	Terminal 18: digital input	[8] Start*
5-12	Terminal 27: digital input	[0] Not used
Volume flow control		
1-00	Control mode	[3] PID closed loop
20-01	Feedback conversion 1	[1] Square root
20-12	Reference/feedback unit	[25] m ³ /h
20-21	Reference 1	2500 m ³ /h
20-93	PID proportional gain	0.5
20-94	PID integration time	2
Scaling in m ³ /h		
3-02	Min. reference	0 m ³ /h*
3-03	Max. reference	5000 m ³ /h
Feedback signal		
20-00	Feedback terminal 1	[2] Analogue input 54*
6-24	Ter. 54 scale min. ref/feedback	0 m ³ /h*
6-25	Ter. 54 scale max. ref/feedback	5000 m ³ /h
Analogue output		
6-50	Terminal 42: analogue output	[102] Feedback 0–20 mA
6-51	Ter. 42 min. scaling	50%
6-52	Ter. 42 max. scaling	75%
Display indication (optional)		
0-20	Display line 1.1	[1601] Reference [unit]
0-22	Display line 1.3	[1652] Feedback [unit]
0-24	Display line 3	[1665] Analogue output 42
* Factory setting		

6.15 Volumetric flow control in m³/h, oversynchronous, feedback signal output 0–20 mA

Volume flow control with integrated process controller.
Internal reference, feedback 0–5000 m³/h on terminal 54.
Feedback output 0–5000 m³/h as 0–20 mA signal on terminal 42.

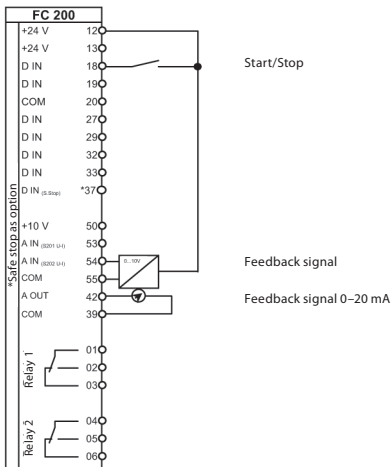

This example constitutes a non-binding recommendation with regard to the General Delivery and Warranty Conditions. It is based on the factory setup and presumes that the motor data has been configured correctly. This recommendation must be verified by the user.

Relevant parameters		
Par.	Function	Setting
0-02	Hz/rpm selection	[1] Hz
4-14	Max. frequency [Hz]	72 Hz
Start/Stop		
5-10	Terminal 18: digital input	[8] Start*
5-12	Terminal 27: digital input	[0] Not used
Volume flow control		
1-00	Control mode	[3] PID closed loop
20-01	Feedback conversion 1	[1] Square root
20-12	Reference/feedback unit	[25] m ³ /h
20-21	Reference 1	2500 m ³ /h
20-93	PID proportional gain	0.5
20-94	PID integration time	2
Scaling in m ³ /h		
3-02	Min. reference	0 m ³ /h*
3-03	Max. reference	5000 m ³ /h
Feedback signal		
20-00	Feedback terminal 1	[2] Analogue input 54*
6-24	Ter. 54 scale min. ref/feedback	0 m ³ /h*
6-25	Ter. 54 scale max. ref/feedback	5000 m ³ /h
Analogue output		
6-50	Terminal 42: analogue output	[102] Feedback 0–20 mA
6-51	Ter. 42 min. scaling	50%
6-52	Ter. 42 max. scaling	75%
Display indication (optional)		
0-20	Display line 1.1	[1601] Reference [unit]
0-22	Display line 1.3	[1652] Feedback [unit]
0-24	Display line 3	[1665] Analogue output 42
* Factory setting		

6.16 Pressure control in bar, basic cascade controller

Pressure control with integrated process controller.

The VLT® AQUA Drive cascade controller can switch on additional pumps via the relays if necessary.

Controlled variable 0–10 bar on terminal 54.

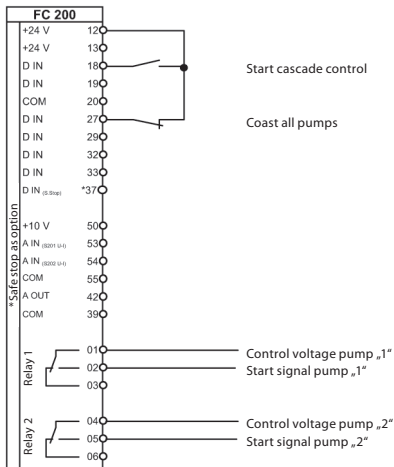

This example constitutes a non-binding recommendation with regard to the General Delivery and Warranty Conditions. It is based on the factory setup and presumes that the motor data has been configured correctly. This recommendation must be verified by the user.

Relevant parameters		
Par.	Function	Setting
0-02	Hz/rpm selection	[1] Hz
3-10	Preset ref. [0]	25%
Start/Stop		
5-10	Terminal 18: digital input	[8] Start*
5-12	Terminal 27: digital input	[2] Coast (inverse)*
Pressure control		
1-00	Control mode	[3] PID closed loop
20-12	Reference/feedback unit	[7] bar
20-21	Reference 1	5 bar
20-93	PID proportional gain	0.5
20-94	PID integration time	0.8
Scaling in bar		
3-02	Min. reference	0 bar*
3-03	Max. reference	10 bar
Feedback signal		
20-00	Feedback terminal 1	[2] Analogue input 54*
6-24	Ter. 54 scale min. ref/feedback	0 bar
6-25	Ter. 54 scale max. ref/feedback	10 bar
20-73	Min. feedback level	0 bar
20-74	Maximum feedback level	10 bar
Cascade controller		
25-00	Cascade controller	[1] Enabled
25-05	Preset control group	[1] Yes*
25-06	Number of pumps	[1] 3 pumps
25-45	Switch-on threshold [Hz]	45 Hz*
Relay		
5-40[0]	Relay 1 function	[212] Casc. pump 2**
5-40[2]	Relay 2 function	[213] Casc. pump 3**
* Factory setting		

If you have any questions or need additional assistance, contact your authorised retailer or designated contact person.

The current contact data can be found on the website of the appropriate country or under Contact at www.danfoss.com.

Danfoss can accept no responsibility for possible errors in catalogues, brochures and other printed material. Danfoss reserves the right to alter its products without notice. This also applies to products already on order provided that such alterations can be made without subsequential changes being necessary in specifications already agreed. All trademarks in this material are property of the respective companies. Danfoss and the Danfoss logotype are trademarks of Danfoss A/S. All rights reserved.