



neptronic®

Steam Humidifier

SKE4-N Series

Installation Instructions and User Manual



READ AND SAVE THESE INSTRUCTIONS



**Intertek
4011008**

Foreword

Neptronic Company Overview

Founded in 1976, we're a private corporation that designs, manufactures and distributes products for the HVAC industry. Our product line includes intelligent controllers, electronic actuators, actuated valves, humidifiers and electric heaters.

Our products are designed and manufactured by over 250 dedicated employees in our 7,500 m² (80,000 ft²) state-of-the-art facility located in Montreal, Canada. Using a vertical integration model, our entire manufacturing chain is under one roof, from software and hardware development, to SMT circuit board assembly, to sheet metal fabrication, to product testing, ensuring that our products are engineered to last.

We currently hold several national and international patents and with our continued commitment to research and development, we provide innovative products and technologies for the ever-evolving challenges of the HVAC industry. Exporting over 70% of our sales, we have an exclusive distribution network around the globe that provides comprehensive solutions to our worldwide customers.

About the Manual

These installation and operation instructions have been developed to facilitate the installation of the Steam Humidifier.

- The strict application of these instructions will ensure the conformity of your installation and operation as per the manufacturer's recommendations.
- The application of these instructions is one of the conditions for the application of the warranty.
- The application of these instructions does not ensure, at any time conformity to procedures, regulation or local codes, regarding electric installation and connection to local water supply.

This product has been declared to conform to the applicable Canadian and American safety standards and directives and bear the ETL (c) & (us) mark. The Certificate for ETL is available, upon request to the manufacturer.

2018[®]: All rights reserved. This document cannot be reproduced totally or partially by any means whether, electronic, mechanical, photocopy, recording or other, without prior written authorization of Neptronic.

Electricity



All work concerned with electrical installation **MUST** only be performed by skilled and qualified technical personnel, such as an electrician or a technician with appropriate training. The customer is always responsible for ensuring the suitability of the technical personnel.

Please observe the local regulations concerning the provision of electrical installations.

Correct Use

Neptronic systems and its products are designed only for humidification use. Any other application is not considered appropriate for the intended purpose. The manufacturer cannot be made liable for any damage resulting from incorrect use.

General Warranty

This product is subject to the terms and conditions described at <http://www.neptronic.com/Sales-Conditions.aspx>.

Handling and Lifting



Lifting or handling **MUST** be carried out by trained and qualified personnel. Ensure that the lifting operation has been properly planned, assessed for risk and that the equipment has been checked by a competent Health & Safety representative, and effective control measures are in place.

It is the customer's responsibility to ensure that the operators are trained in handling heavy goods and to enforce the relevant lifting regulations.

The Steam Humidifier **MUST** be handled and lifted with care at all times and remain in its original packaging for as long as possible, prior to installation.

The Steam Humidifier package may be carried using a forklift from the underside. Exercise caution before lifting to ensure that the load is balanced.

Unpacking

The Steam Humidifier is shipped inside carton boxes or in a wooden crate. Remove packing and skids prior to commissioning.

Contents

Handling and Lifting	ii
Overview	4
List of Accessories Supplied	4
Available Options	4
Description of Systems	4
Visual Overview	5
Standard Humidifier Unit.....	6
Dimensions and Weight	6
Humidifier with Space Distribution Unit.....	7
Humidifier with Space Distribution Unit - Dimensions and Weight	7
Weather Proof Enclosure.....	8
Weather Proof Enclosure - Dimensions and Weight.....	8
Output and Power Consumption - Humidifier	9
Mechanical Installation	10
General Recommendations	10
Location.....	10
Positioning.....	11
Wall Mounting.....	12
Positioning - Humidifier with SDU.....	15
Maintenance of the SDU	15
Positioning and Mounting - Weather Proof Enclosure Unit	16
General Recommendations	16
Steam Dispersion System	17
Steam Dispersion System Selection	17
Positioning S.A.M. and S.A.M.E2	19
Placement of Steam Pipe in Horizontal Duct	20



Placement of Steam Pipe in Vertical Duct 21

Steam Output Connections 22

 Installation..... 22

 General Recommendations 22

 S Trap Installation on the Steam Line 23

 Position of Steam Outputs 24

 Remote Installation - Humidifier with SDU 25

Plumbing Connections 26

 Water Supply Connections 28

 Water Drain Connections 29

 Weather Proof Enclosure Plumbing Connection 29

 Water Drain Valve 30

Electrical Connections 31

 Low Voltage Control Connections 32

 Printed Circuit Board 32

 Safety Contact Connections 33

 Dry Contacts 33

 ON/OFF Humidifier 34

 Modulating Humidifier 35

 Network Communication 37

 Controls Placement (Steam Dispersed into a Duct or AHU) 38

Controller Configuration 39

 Control Panel Features 39

 Idle Screen 40

 Menu Access 40

 Menu Navigation and Configuration 41

 Menu - General 42

 Menu - User 44

 Menu - Service 44

 Menu - Installation 45

 Menu - Integration 47

 List of Alarms 49

Start-up Procedure 50

 Initial Verification 50

 Start-Up 51

Service 52

 Cleaning the Evaporation Chamber 52

Troubleshooting 56

Exploded View and Bill of Material 57

 Exploded View 57

 Bill of Material 59

Notes 61

Overview

List of Accessories Supplied

The following accessories are supplied with the SKE4 Steam Humidifier:

- 2 sets of keys.
- 2 adjustable collars per steam outlet for the connection of the steam hose.
- 1 hydraulic female compression fitting ¾" (DN20) for the drain output of the evaporation chamber.
- 1 hydraulic female elbow fitting ½" (DN15) for the drain output of the drip pan.
- 1 NPT fitting ½" (DN15) for the water supply connection.
- 2 brackets and screws for wall mounting the humidifier (models SKE4-N02 to SKE4-N60 only).
- 1 Installation Instructions and User Manual.

Available Options

The following options are available when purchasing a SKE4 humidifier:

- Modulating control humidifier (Suffix M, i.e. SKE4-N20M)
- Humidifier for a system supplied with Deionized water or Reverse Osmosis water, having more than 0.0625 ppm of dissolved solids
- Space Distribution Unit mounted on humidifier (SDU) or remotely installed (SDU-REM)
- Weather proof enclosure
- BACnet Network Communication System
- Ethernet (IP) option
- Stainless steel humidifier cabinet

Description of Systems

System	Description
<i>Evaporation Chamber</i>	Removable metallic container in which steam is produced. It is the most important part of the humidifier.
<i>Space Distribution Unit (SDU)</i>	Integrated steam distribution unit to humidify air when there is no duct system. Optional feature available for certain humidifier models.
<i>Multi-Steam System</i>	Custom made system for steam distribution. This system is designed for applications where absorption distances are very short (less than 3 feet or 900 mm).
<i>Steam Absorption Manifold (S.A.M.)</i>	Steam manifold adapted to air duct size. Allows steam absorption for relatively short distance applications (less than 5 feet or 1500 mm).
<i>Steam Absorption Manifold with 2 Eyelets (S.A.M.E2)</i>	Steam manifold with two eyelets, adapted for applications with restricted air duct dimensions. Allows steam absorption for relatively short distance applications (less than 5 feet or 1500 mm).



Visual Overview

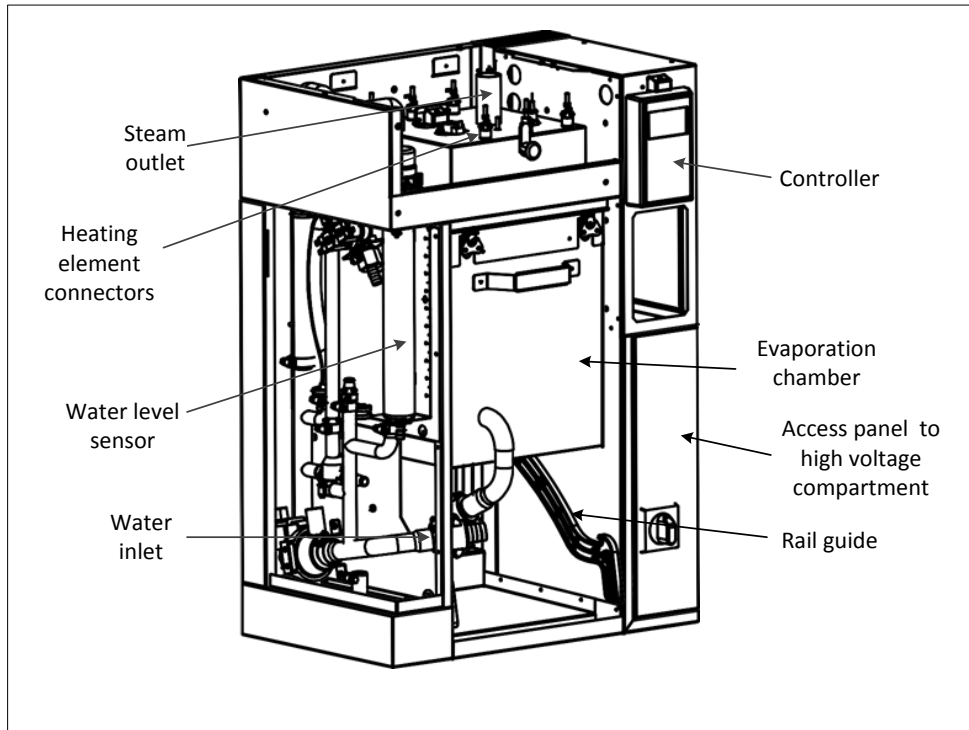

Illustration 1 - Overview of the Humidifier (Left Side)

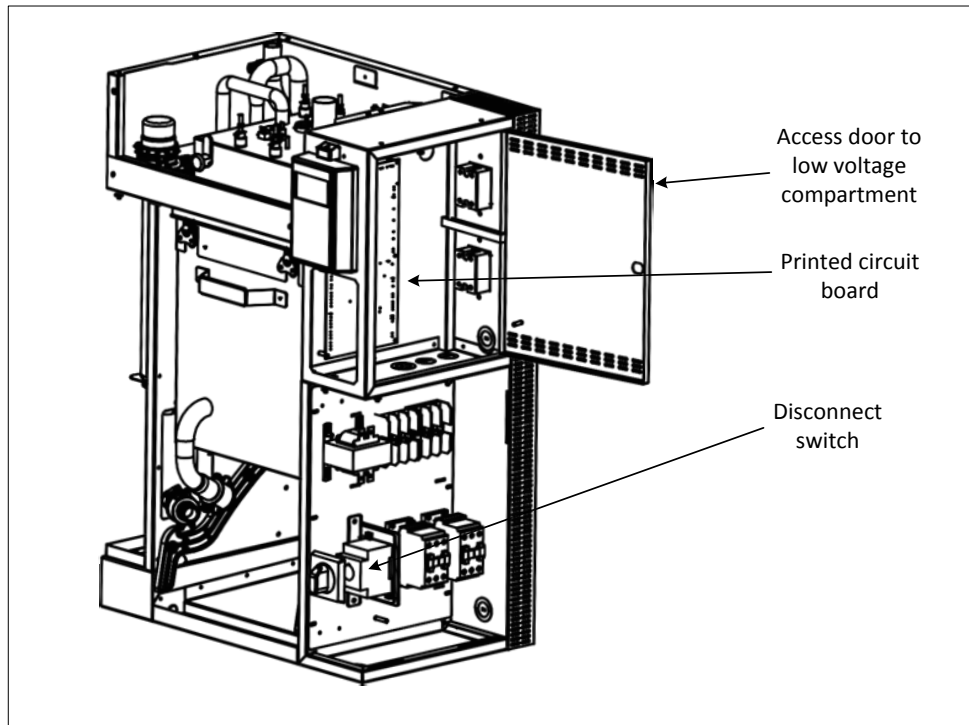

Illustration 2 - Overview of the Humidifier (Right Side)



Standard Humidifier Unit

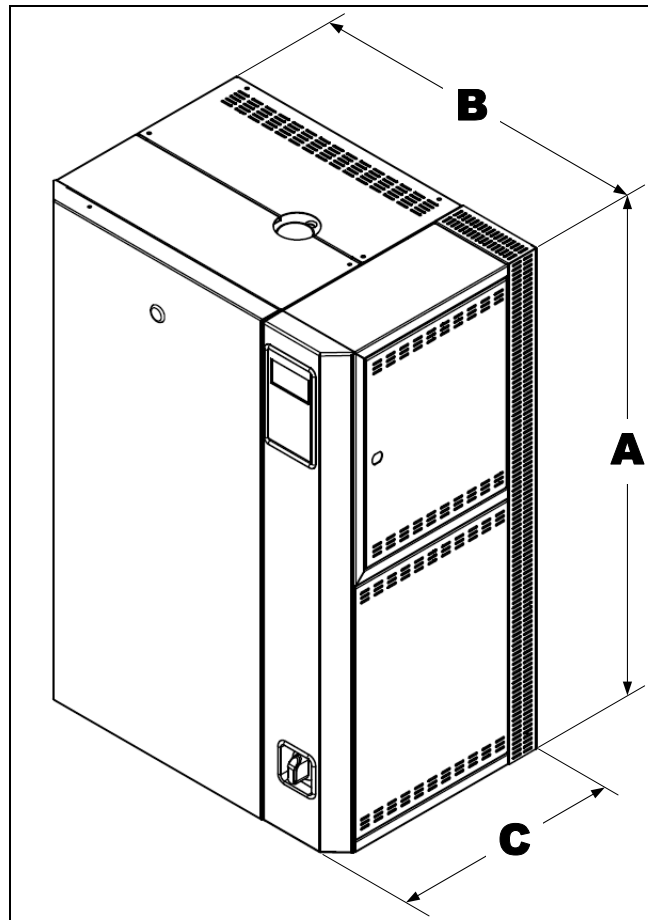

Illustration 3 - SKE4 Steam Humidifier

Dimensions and Weight

Table 1 - Dimensions and Weight

Model	Dimensions of the Cabinet (inch) [mm]			Weight (lb) [kg]	
	A	B	C	Empty	Full
SKE4-N02 SKE4-N04 SKE4-N06	23 [584]	19 3/8 [492]	13 3/4 [349]	71 [32]	85 [39]
SKE4-N10 SKE4-N14 SKE4-N16 SKE4-N20 SKE4-N30	32 [813]	22 1/4 [565]	15 1/8 [384]	107 [49]	152 [69]
SKE4-N20 L SKE4-N40 SKE4-N50 SKE4-N60	32 [813]	33 1/4 [845]	15 1/8 [384]	143 [65]	233 [106]
SKE4-N30 X SKE4-N40 X SKE4-N70 SKE4-N80 SKE4-N90	48 [1219]	33 [838]	24 3/8 [619]	320 [145]	444 [200]



Humidifier with Space Distribution Unit

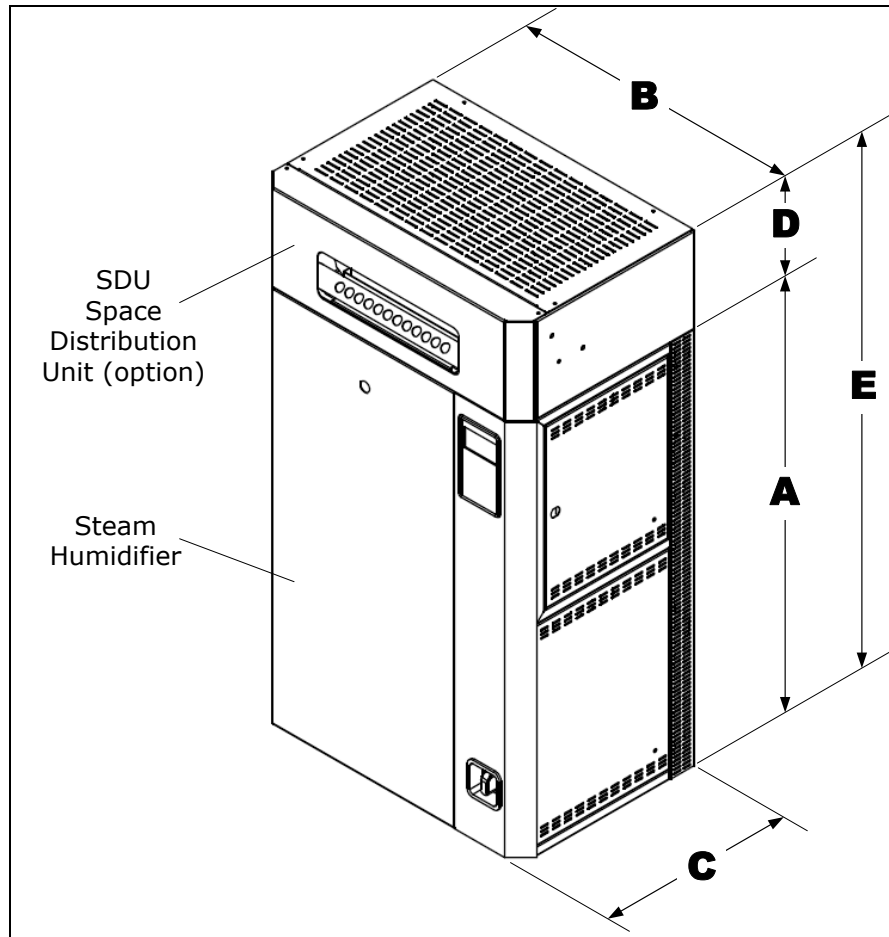

Illustration 4 - Steam Humidifier with Space Distribution Unit

Humidifier with Space Distribution Unit - Dimensions and Weight

Table 2 - Dimensions and Weight of SDU

Model	Dimensions of the Cabinet (inch) [mm]					Weight (lb) [kg]		SDU (lb) [kg]
	A	B	C	D	E	Empty	Full	
SKE4-N02 SKE4-N04 SKE4-N06	23 [584]	19 ³ / ₈ [492]	13 ³ / ₄ [349]	6 ³ / ₄ [171]	29 ³ / ₄ [755]	86 [39]	100 [45]	SDU4-1 15 [7]
SKE4-N10 SKE4-N14 SKE4-N16	32 [813]	22 ¹ / ₄ [565]	15 ¹ / ₈ [384]	7 ³ / ₄ [197]	39 ³ / ₄ [1010]	127 [58]	172 [78]	SDU4-2 20 [9]
SKE4-N20 SKE4-N30	32 [813]	22 ¹ / ₄ [565]	15 ¹ / ₈ [384]	11 ³ / ₈ [289]	43 ³ / ₈ [1102]	137 [62]	182 [83]	SDU4-3 30 [14]



Weather Proof Enclosure

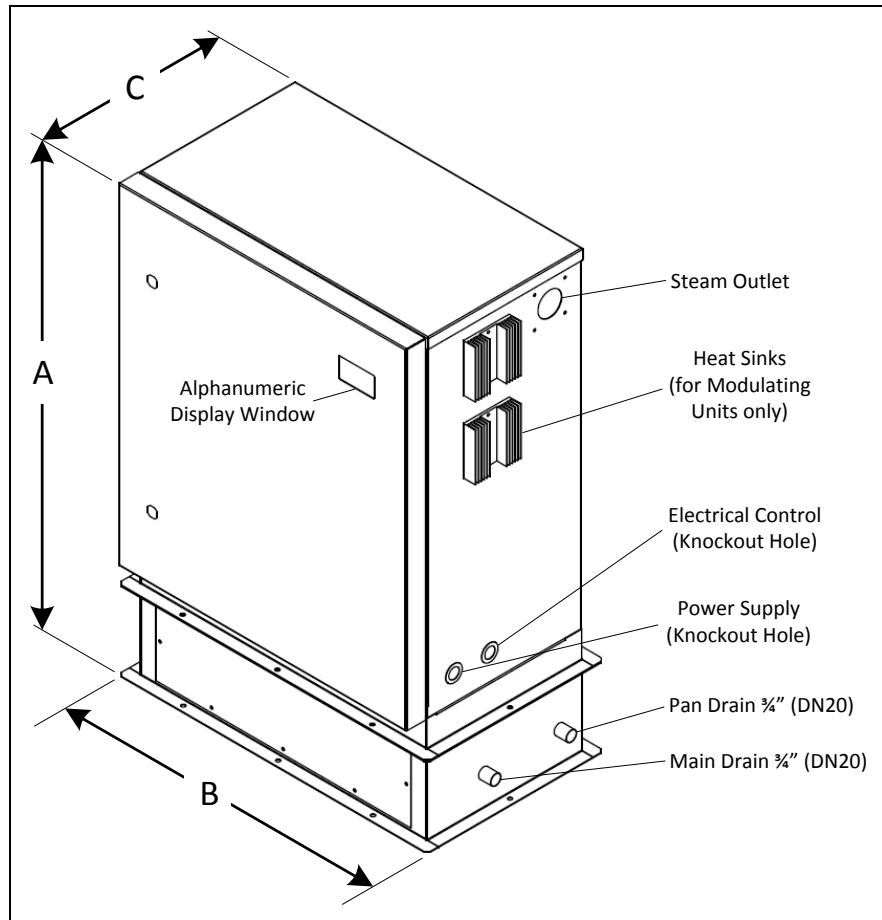

Illustration 5 - Weather Proof Enclosure

Weather Proof Enclosure - Dimensions and Weight

Table 3 - Weather Proof Enclosure: Dimensions and Weight

Model	Dimensions of the Cabinet (inch) [mm]			Weight (lb) [kg]	
	A	B	C	Empty	Full
SKE4-N02 SKE4-N04 SKE4-N06	36.5 [927]	25.9 [658]	14.8 [376]	100 [45]	115 [52]
SKE4-N10 SKE4-N14 SKE4-N16 SKE4-N20 SKE4-N30	41 1/8 [1045]	29.8 [757]	15 1/8 [384]	130 [59]	175 [80]
SKE4-N20 L SKE4-N40 SKE4-N50 SKE4-N60	41 1/8 [1045]	40.8 [1036]	15 1/8 [384]	195 [89]	285 [129]
SKE4-N30 X SKE4-N40 X SKE4-N70 SKE4-N80 SKE4-N90	55.8 [1417]	38 [965]	28.6 [727]	405 [184]	529 [240]



Output and Power Consumption - Humidifier

Table 4 - Output and Power Consumption

Model	Steam		Consumption								Steam Output	
	Capacity (lb/hr) [kg/hr]	Power (kW)	Amperage (A)								Qty	Diameter (inch) [mm]
			120/1	240/1	208/1	208/3	480/1	480/3	600/1	600/3		
SKE4-N02	6 [2.7]	2	17	8.5	10	-	4.5	-	3.5	-	1	1 3/8 [35]
SKE4-N04	12 [5.5]	4	-	17	19	11.5	8.5	5	7	4	1	1 3/8 [35]
SKE4-N06	18 [8]	6	-	26	30	16.5	13	7.2	10.5	6	1	1 3/8 [35]
SKE4-N10	30 [14]	10	-	-	-	28	-	12	-	10	1	1 3/8 [35]
SKE4-N14	40 [19]	13.5	-	-	-	38	-	16.5	-	13.5	1	1 3/8 [35]
SKE4-N16	48 [21.8]	16	-	-	-	45	-	-	-	16	1	2 1/8 [54]
SKE4-N20	60 [28]	20	-	-	-	-	-	25	-	20	1	2 1/8 [54]
SKE4-N30	90 [41]	30	-	-	-	-	-	36	-	30	1	2 1/8 [54]
SKE4-N20 L	60 [28]	20	-	-	-	56	-	-	-	-	1	3 [76]
SKE4-N40	120 [56]	40	-	-	-	-	-	50	-	40	1	3 [76]
SKE4-N50	150 [68]	50	-	-	-	-	-	60	-	50	1	3 [76]
SKE4-N60	180 [82]	60	-	-	-	-	-	72	-	60	1	3 [76]
SKE4-N30 X	90 [41]	30	-	-	-	83.4	-	-	-	-	1	3 [76]
SKE4-N40 X	120 [56]	40	-	-	-	111	-	-	-	-	1	3 [76]
SKE4-N70	210 [95]	70	-	-	-	-	-	84	-	70	1	3 [76]
SKE4-N80	240 [108]	80	-	-	-	-	-	96	-	81	2	3 [76]
SKE4-N90	270 [122]	90	-	-	-	-	-	109	-	91	2	3 [76]



WARNING: For Modulating Humidifier, maintain the maximum power of the electrical installations according to the information in Table 4 - Output and Power Consumption. Do not consider a possible reduction of steam output due to modulation.

Mechanical Installation

General Recommendations



WARNING: Risk of electric shock. Disconnect the appliance from electric supply before commencing installation.



Note: Mechanical installation must conform to local codes and regulations.

Location



WARNING: The SKE4 series is designed for indoor installation only.

For outdoor installation, the SKE4 must be installed using a Neptronic weather proof enclosure (see Positioning and Mounting - Weather Proof Enclosure Unit on page 16).

Failure to follow these guidelines will void the warranty.

Consider the following points before deciding the location for the SKE4 Steam Humidifier:

- Plan a location that is easy to access and permits an easy inspection and servicing of the humidifier.
- Do not install the humidifier where failure of the appliance could cause damage to the building structure or to other expensive equipment.
- Ensure that the location is well ventilated and that the ambient temperature is less than 86°F (30°C).
- Consider the total steam line length between the humidifier and the steam distributor based on the steam line material type:
 - For flexible steam hose, total steam line must not exceed 16 feet (5 meters). For longer distances, use insulated hard piping.
 - For insulated hard piping, the total steam line is determined by the humidifier capacity: one equivalent foot for each lb/hr capacity of the humidifier (0.67 m for each kg/hr), with a maximum of 50 feet (15 m). For longer steam line runs, consult factory.



Positioning

- Ensure that the front panel, the left side (plumbing compartment) and the right side (electrical compartment) are accessible in order to permit servicing.
- Leave a clearance of at least 48" (1.2 m) to the front panel and 12" (0.3 m) on the left and right sides of the humidifier.
- Leave a clearance of at least 20" (0.5 m) on top of the humidifier.

For models SKE4-N02 to SKE4-N60:

- Mount the humidifier at a minimum height of 24" (0.6 m) above floor level.
- Leave a clearance of at least 10" (0.25 m) under the humidifier for installation of water supply, drain piping and electrical connections.

For models SKE4-N30 X to SKE4-N90:

- These models are designed to be installed directly on the floor. Adjustable legs are provided in order to ensure proper level.
- Provide a level, solid foundation and ensure that the floor beneath the humidifier is water proof to withstand any water spillage during servicing or in the event of a problem.

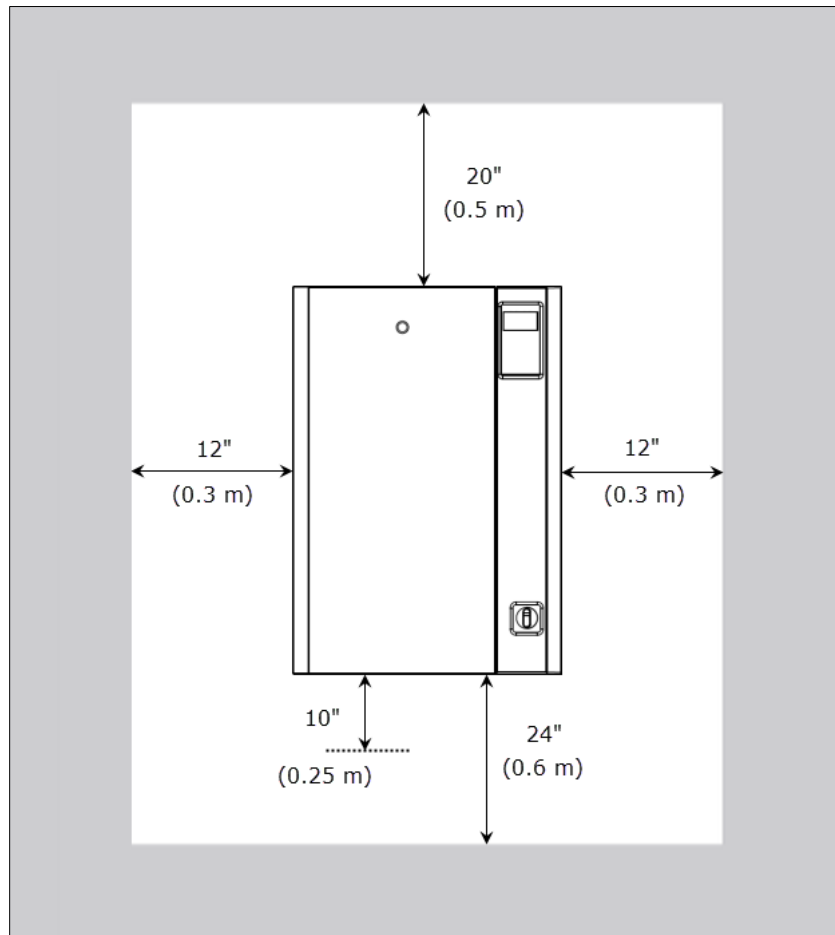

Illustration 6 - Positioning the Humidifier

Wall Mounting



CAUTION: Risk of malfunction. The humidifier must be placed at an equal level.

CAUTION: Risk of overheating. Do not block the ventilation openings located on the cabinet.

Before proceeding, check the strength of the chosen support or wall (brick, concrete, stud partition wall) on which the humidifier will be mounted. See the Dimensions and Weight section (page 6) to know the weight of the unit.

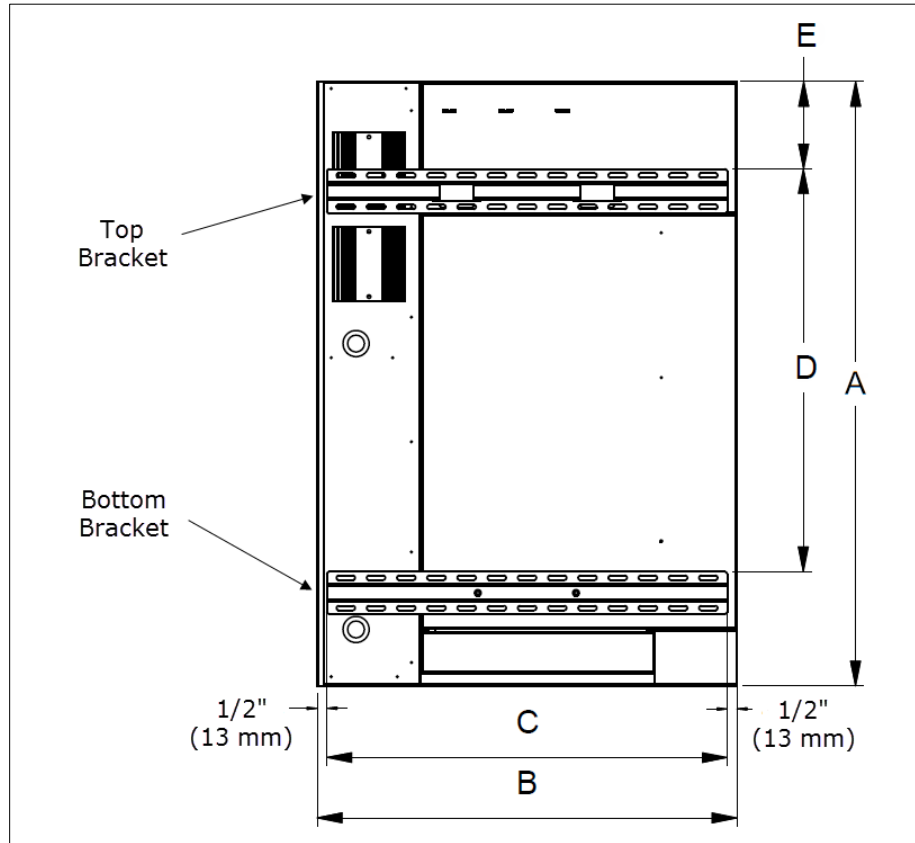

Illustration 7 - Mounting Bracket Positioning

Table 5 - Positioning Lines of Mounting Brackets

Model	Dimensions (inch) [mm]				
	A	B	C	D	E
SKE4-N02 SKE4-N04 SKE4-N06	23 [584]	19 3/8 [492]	18 3/8 [467]	18 3/8 [467]	7/8 [22]
SKE4-N10 SKE4-N14 SKE4-N16 SKE4-N20 SKE4-N30	32 [813]	22 1/4 [565]	21 1/4 [540]	21 1/4 [540]	7/8 [22]
SKE4-N20 L SKE4-N40 SKE4-N50 SKE4-N60	32 [813]	33 1/4 [845]	28 1/4 [718]	21 1/4 [540]	7/8 [22]



Note: Models SKE4-N30X to SKE4-N90 cannot be wall mounted and must be properly secured to the ground using the adjustable legs.



To wall mount the humidifier, perform the following steps:

1. Place the top bracket (supplied) on the support or wall as per the dimensions specified in Table 5 - Positioning Lines of Mounting Brackets.
2. Drill 4 screws (not supplied) into the slotted holes of the top bracket, to secure the bracket to the support or wall.
3. Place the bottom bracket (supplied) on the support or wall as per the dimensions specified in Table 5 - Positioning Lines of Mounting Brackets.
4. Drill 4 screws (not supplied) into the slotted holes of the bottom bracket, to secure the bracket to the support or wall.

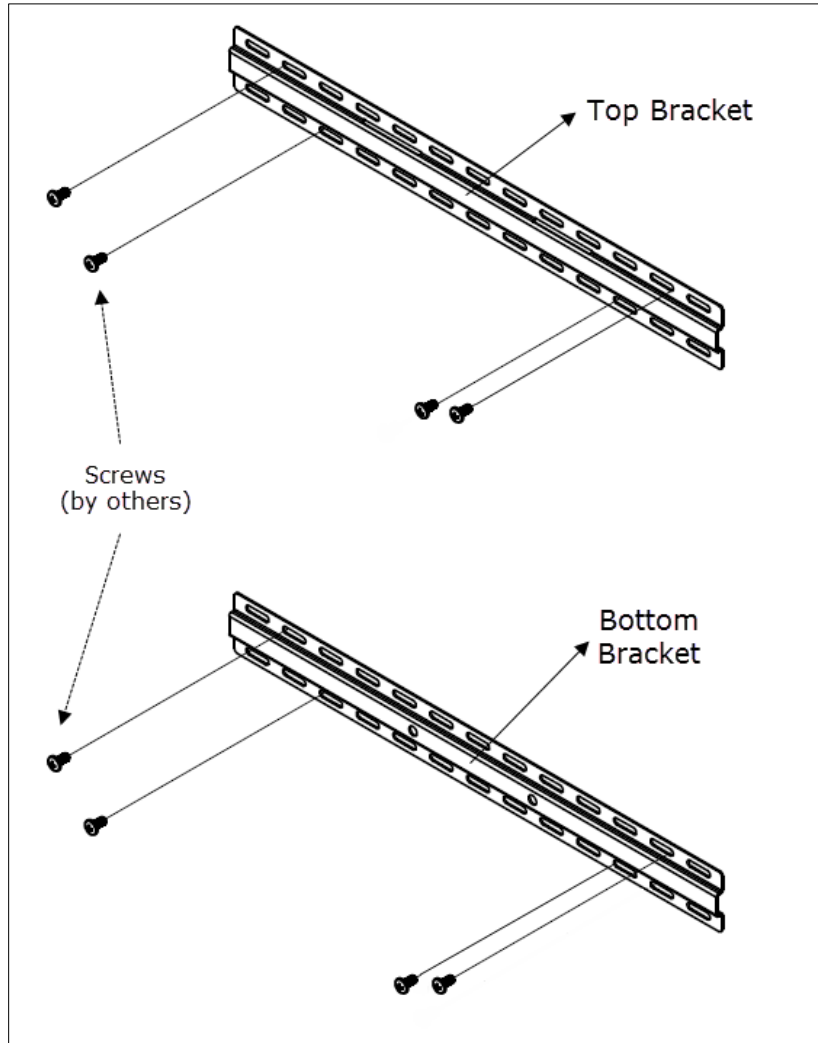

Illustration 8 - Mounting Bracket Attachment



5. Secure the humidifier to the top bracket, by placing the back inserts into the open slots located on the edge of the center of the top bracket.

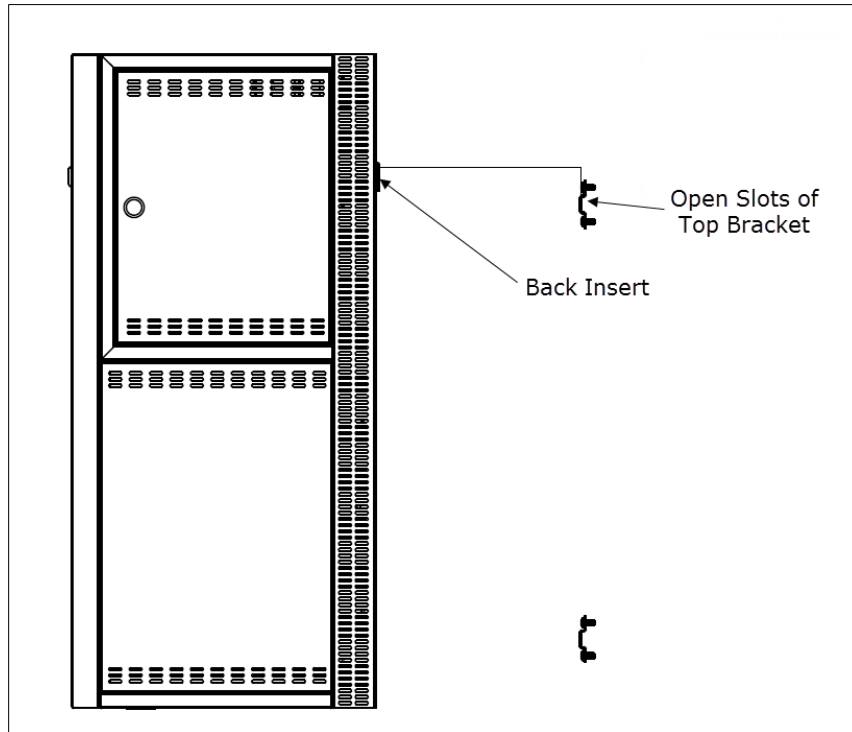

Illustration 9 - Top Mounting Bracket Connection

6. Open the front door of the humidifier to gain access to the slotted holes located in the back of the cabinet. Verify that the holes are aligned with the ones located in the center of the bottom bracket.
7. From inside the humidifier, drill 2 (**models SKE4-N02 to N30**) or 4 (**models SKE4-N20L to N60**) screws (supplied) into the center of the bottom bracket, in order to secure the humidifier to the support or wall.

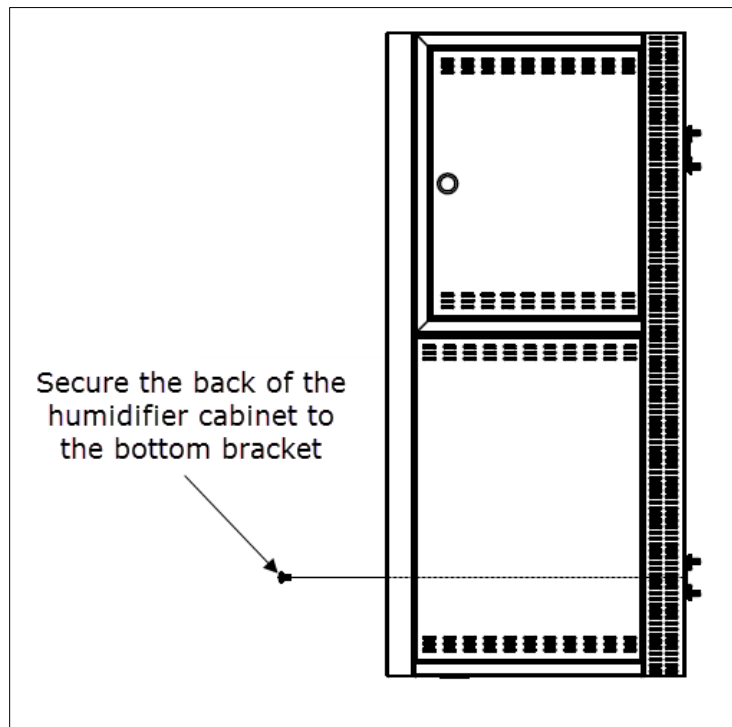

Illustration 10 - Bottom Mounting Bracket Connection



Positioning - Humidifier with SDU

- The SDU must be installed in an environment where the air is relatively clean. This will prevent the blower from getting clogged with dust.
- The humidifier must be mounted such that the SDU fan section is at least 78" (2 m) above the floor.
- Allocate a minimum clearance of 18" (0.45 m) from the ceiling to avoid ceiling and wall condensation.
- If additional ventilation is not present, ensure that the fan has a clearance of at least 54" (1.35 m) from the ceiling.

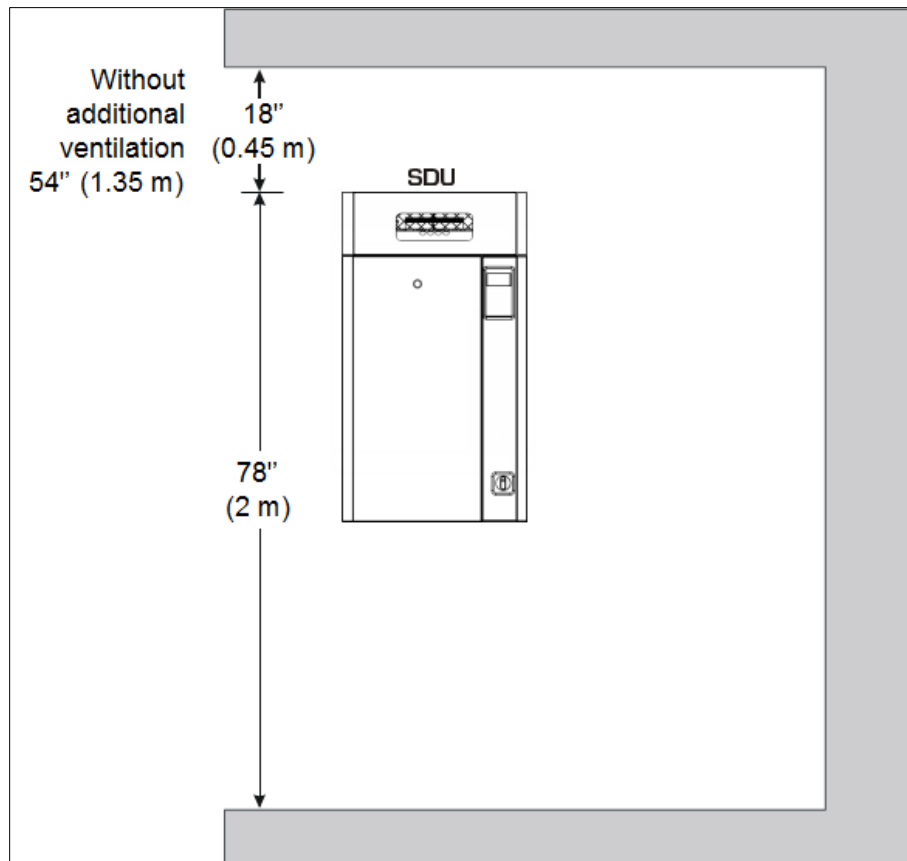

Illustration 11 - SDU Mounted on Humidifier

Maintenance of the SDU

Clean the blower if there is an accumulation of dust.



Positioning and Mounting - Weather Proof Enclosure Unit

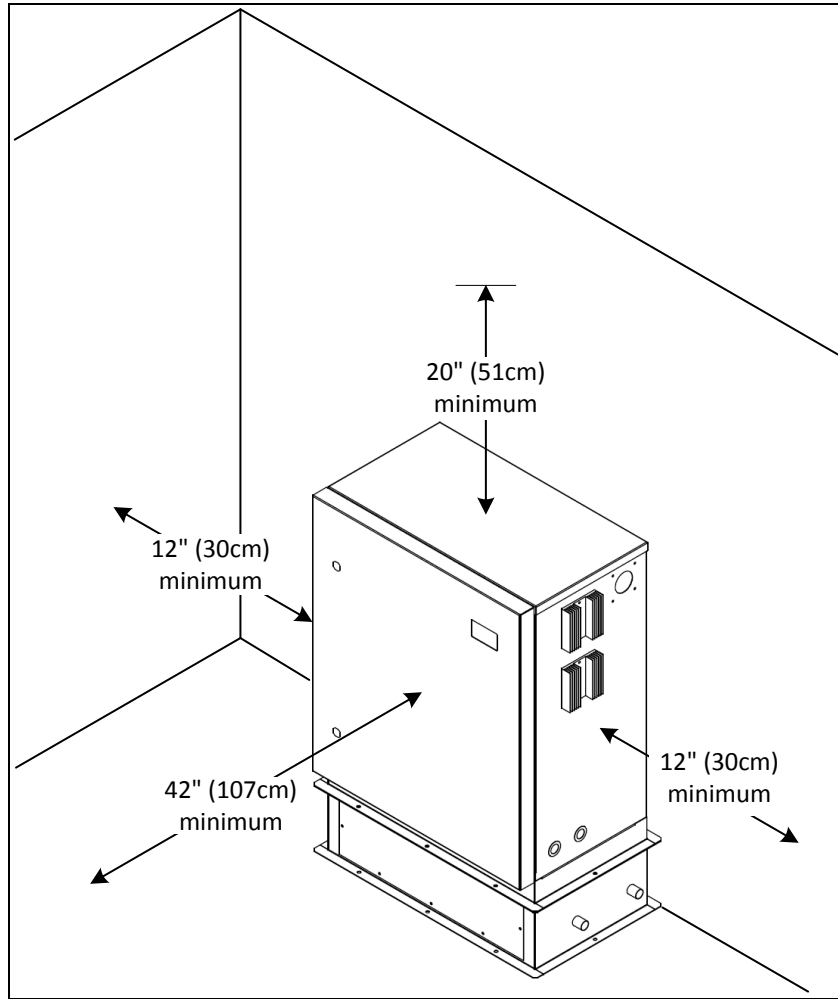

Illustration 12 - Weather Proof Enclosure Unit

General Recommendations

- Plan a location that is easy to access and permits an easy inspection and servicing of the humidifier.
- Do not install the humidifier where failure of the appliance could cause damage to the building structure or to other expensive equipment.
- Maintain the following minimum clearances while installing to enable access for inspection and servicing.

Side	Minimum Clearance
Top	20" (51 cm)
Both sides	12" (30 cm)
Front	42" (107 cm)

- The humidifier is designed to be installed directly on the floor/roof or a curb.
- Provide a level, solid foundation for the humidifier.
- Ensure that the floor/roof beneath the humidifier is water proof to withstand any water spillage during servicing or if a problem occurs.
- Attach the SKE4 enclosure securely and safely.



Steam Dispersion System

Steam Dispersion System Selection

In order to prevent the accumulation of condensation in air ducts, Neptronic has designed four basic configurations of steam distribution systems to provide the most economical solution for any particular application.

Steam Absorption Manifold (S.A.M.) Horizontal Duct

The S.A.M. system is suitable for installations where absorption distances are short, less than 5 feet (1500 mm), and/or low duct temperatures are in effect.

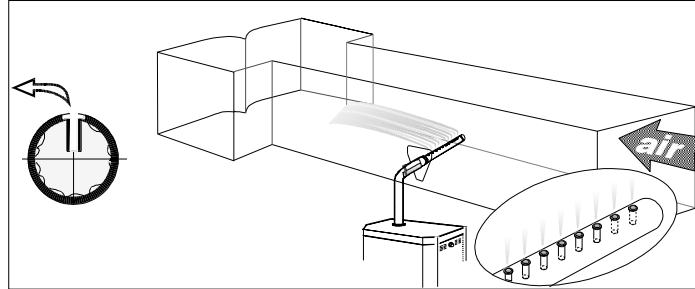

Illustration 13 - Steam Absorption Manifold (S.A.M.) Horizontal Duct

Steam Absorption Manifold (S.A.M.E2) Horizontal Duct

The S.A.M.E2 system is suitable for installations where absorption distances are short, less than 5 feet (1500 mm), and/or low duct temperatures are in effect. S.A.M.E2 are used in applications with restricted duct dimensions.

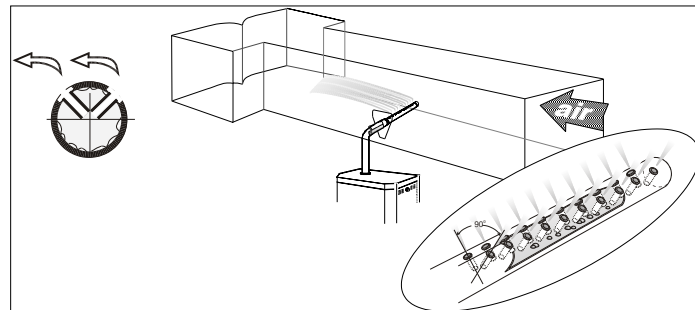

Illustration 14 - Steam Absorption Manifold (S.A.M.E2) Horizontal Duct

Steam Absorption Manifold (S.A.M. or S.A.M.E2) Vertical Duct

S.A.M. or S.A.M.E2 systems for vertical ducts are used when the absorption distances are normal and the requirement is for an economical and efficient solution.

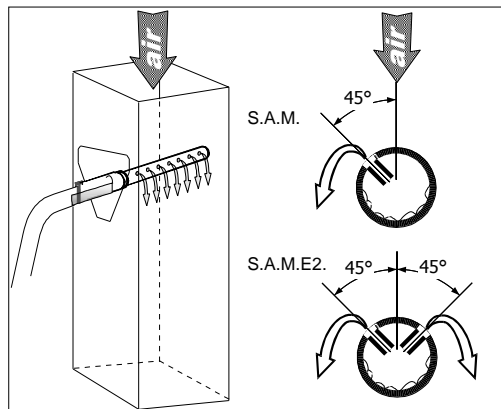

Illustration 15 - Steam Absorption Manifold (S.A.M. or S.A.M.E2) Vertical Duct

Multi-Steam System

The Multi-Steam system is used in critical locations in air handling systems, particularly where absorption distances are very short, less than 3 feet (900 mm), or where low air duct temperatures are present. The Multi-Steam is custom made to the dimensions of the duct or AHU.

Instructions to install the Multi-Steam system are described in a specific installation instructions manual enclosed with the Multi-Steam system.

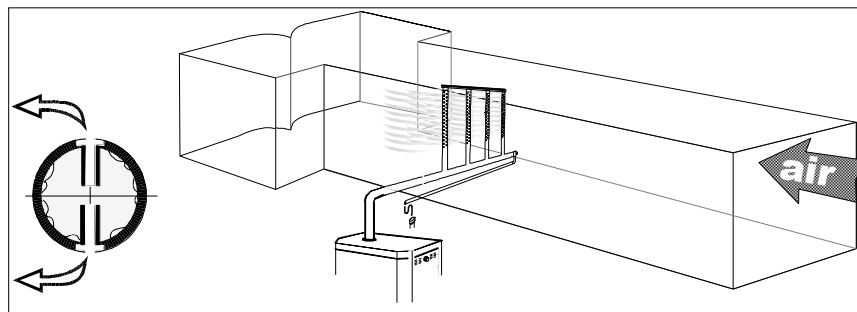

Illustration 16 - Multi Steam System

Positioning S.A.M. and S.A.M.E2

Duct Mounting

The steam manifold must be mounted and secured through the side of the air handling unit or duct. Ensure that provisions are made for safe accessibility, ideally with an observation light and window. Ensure that the construction of the duct wall is suitable enough to support the steam pipe for the duration of the installation life.

The dimension of the hole size in the duct must be as follows:

Steam Manifold Ø	Hole Size ØA
1 3/8" (35 mm)	2" (51 mm)
2 1/8" (54 mm)	3" (76 mm)

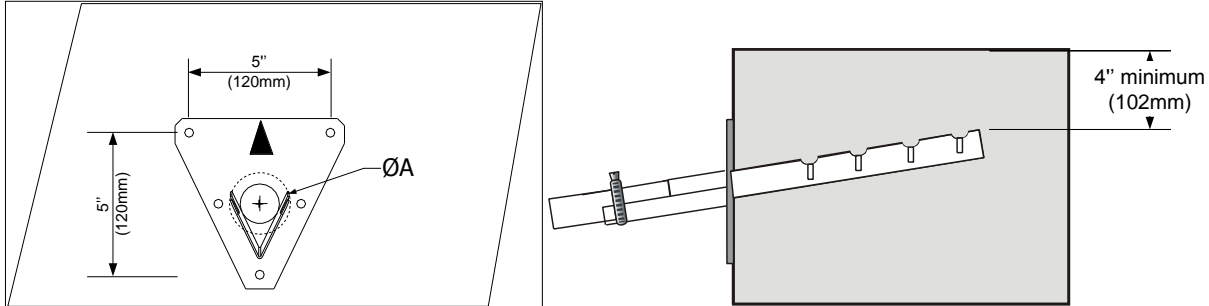

Illustration 17 - Duct Hole Dimensions and Minimum Distance



WARNING: Risk of condensation. Ensure that the minimum distance at the end of the manifold is at least 4" (102 mm) from the top of the duct.

Recommendation for S.A.M. Distribution Pipes

Table 6 - Recommendation for S.A.M. Distribution Pipes

Model	Max Capacity		Distribution Pipes				Max Static Pressure	
	lb/hr	kg/hr	Qty		Diameter (in) [mm]		in. of water	Pa
SKE4-N02	6	2.7	1		1 3/8 [35]		5	1245
SKE4-N04	12	5.5						
SKE4-N06	18	8						
SKE4-N10	30	14						
SKE4-N14	40	19						
SKE4-N16	48	22	1	2	2 1/8 [54]	1 3/8 [35]	5	1245
SKE4-N20	60	28						
SKE4-N30	90	41	2		2 1/8 [54]		5	1245
SKE4-N20 L	60	28						
SKE4-N40	120	56						
SKE4-N50	150	68						
SKE4-N60	180	82	3					

For higher static pressure, contact the manufacturer.



Note: A steam header having an inlet of 3" (76 mm) and two or three outlets of 2 1/8" (54 mm) is required when using S.A.M. steam manifolds for models SKE4-N20L to SKE4-N60 (purchased separately).

Placement of Steam Pipe in Horizontal Duct

1 3/8" (35mm) Diameter Pipe

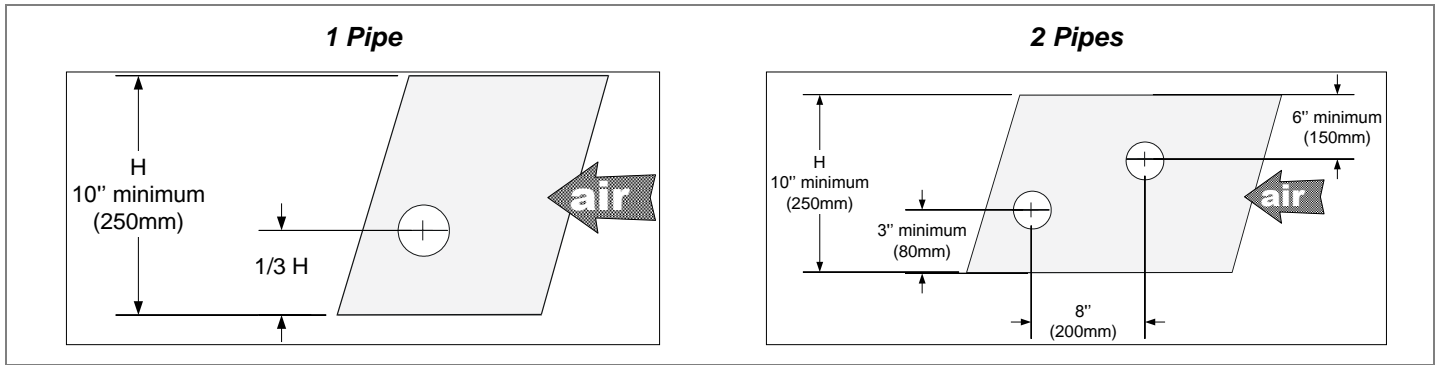

Illustration 18 - 1 3/8" (35 mm) Diameter Pipe Placement: Horizontal Duct

2 1/8" (54mm) Diameter Pipe

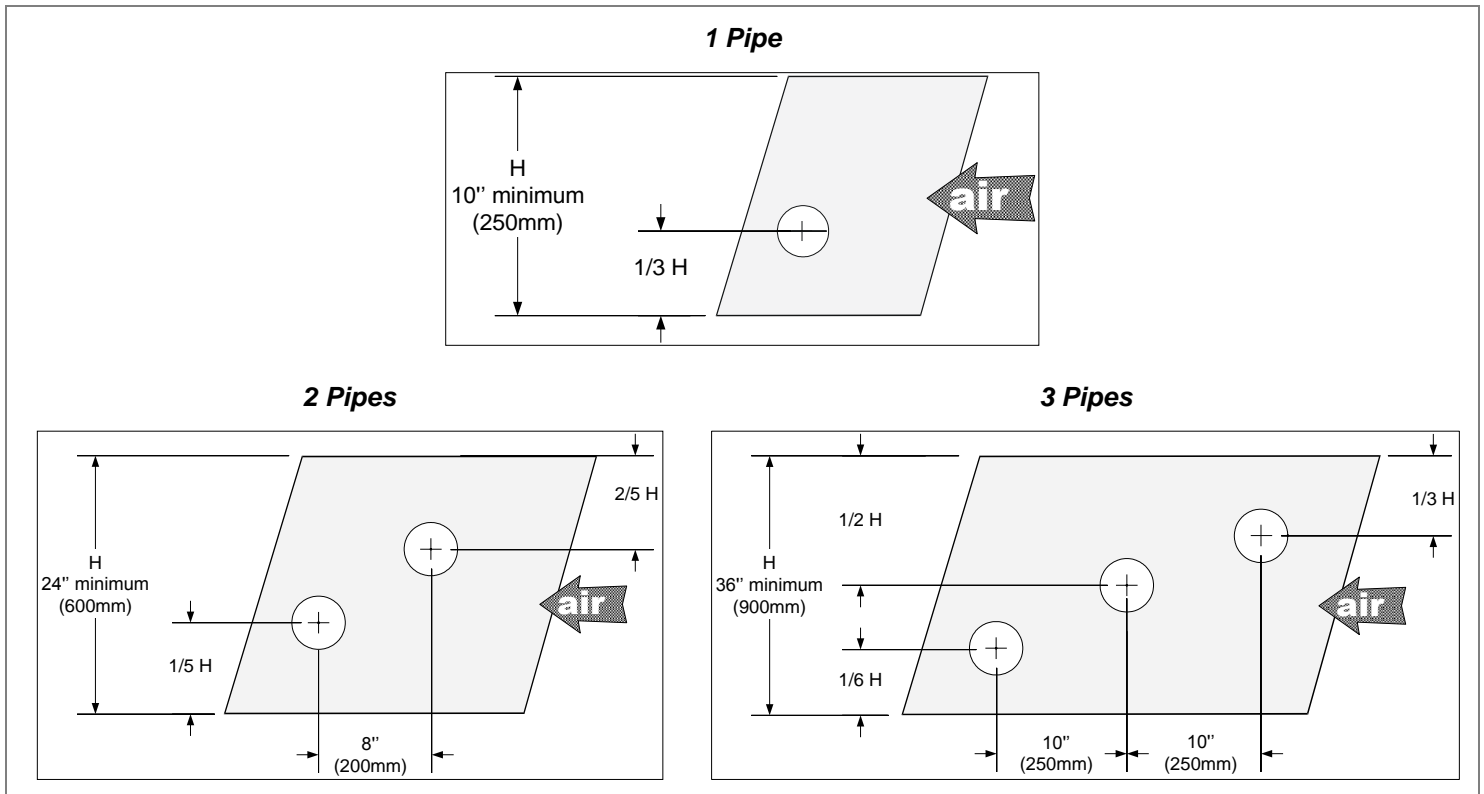

Illustration 19 - 2 1/8" (54 mm) Diameter Pipe Placement: Horizontal Duct



Note: 2 1/8" (54 mm) steam pipe must be supported on the end by appropriate duct hanger or strap (supplied by others).

Placement of Steam Pipe in Vertical Duct

Eyelet Orientation

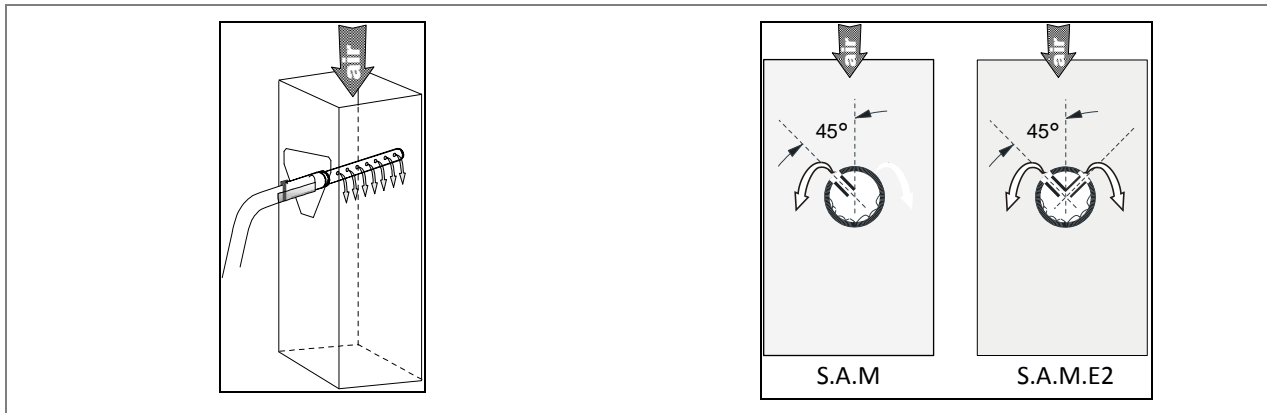

Illustration 20 - Eyelet Orientation

1 3/8" (35 mm) Diameter Pipe

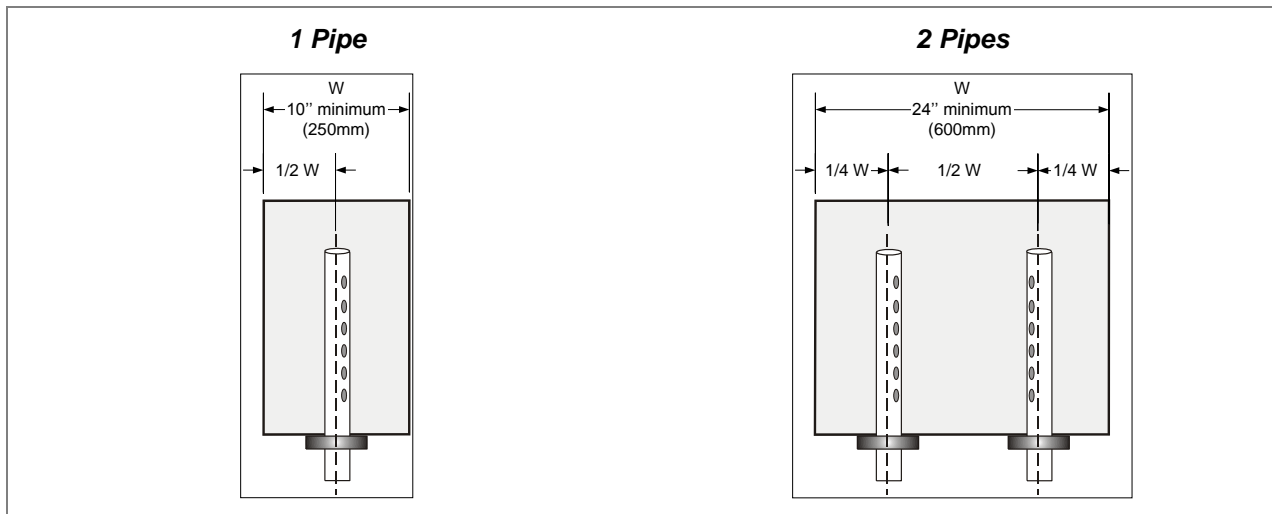

Illustration 21 - 1 3/8" (35 mm) Diameter Pipe Placement: Vertical Duct

2 1/8" (54 mm) Diameter Pipe

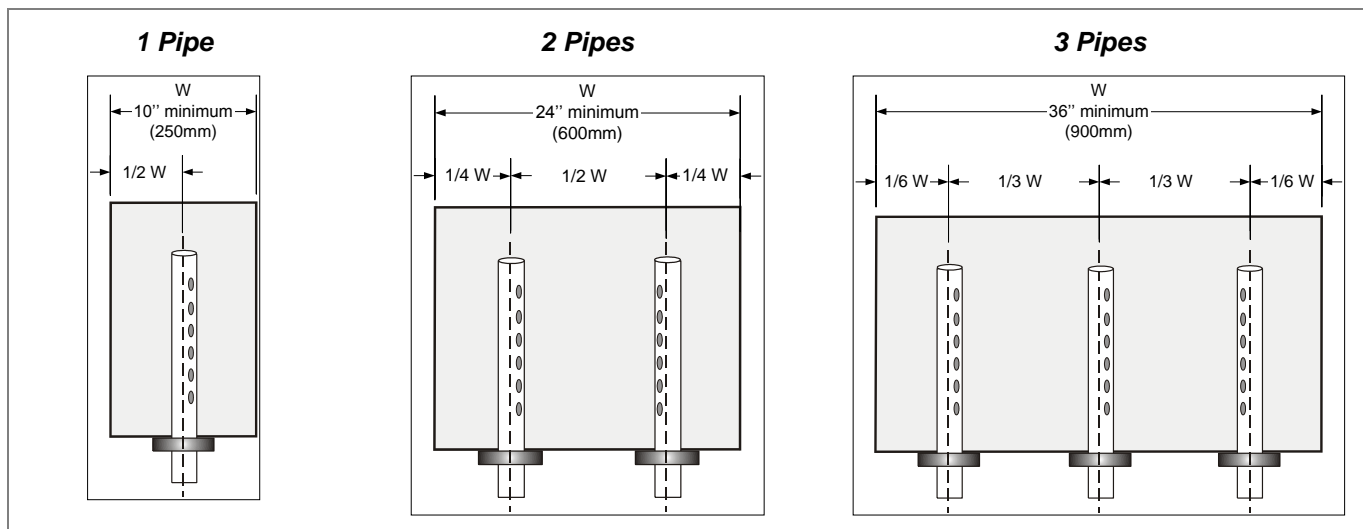

Illustration 22 - 2 1/8" (54 mm) Diameter Pipe Placement: Vertical Duct

Steam Output Connections

Installation

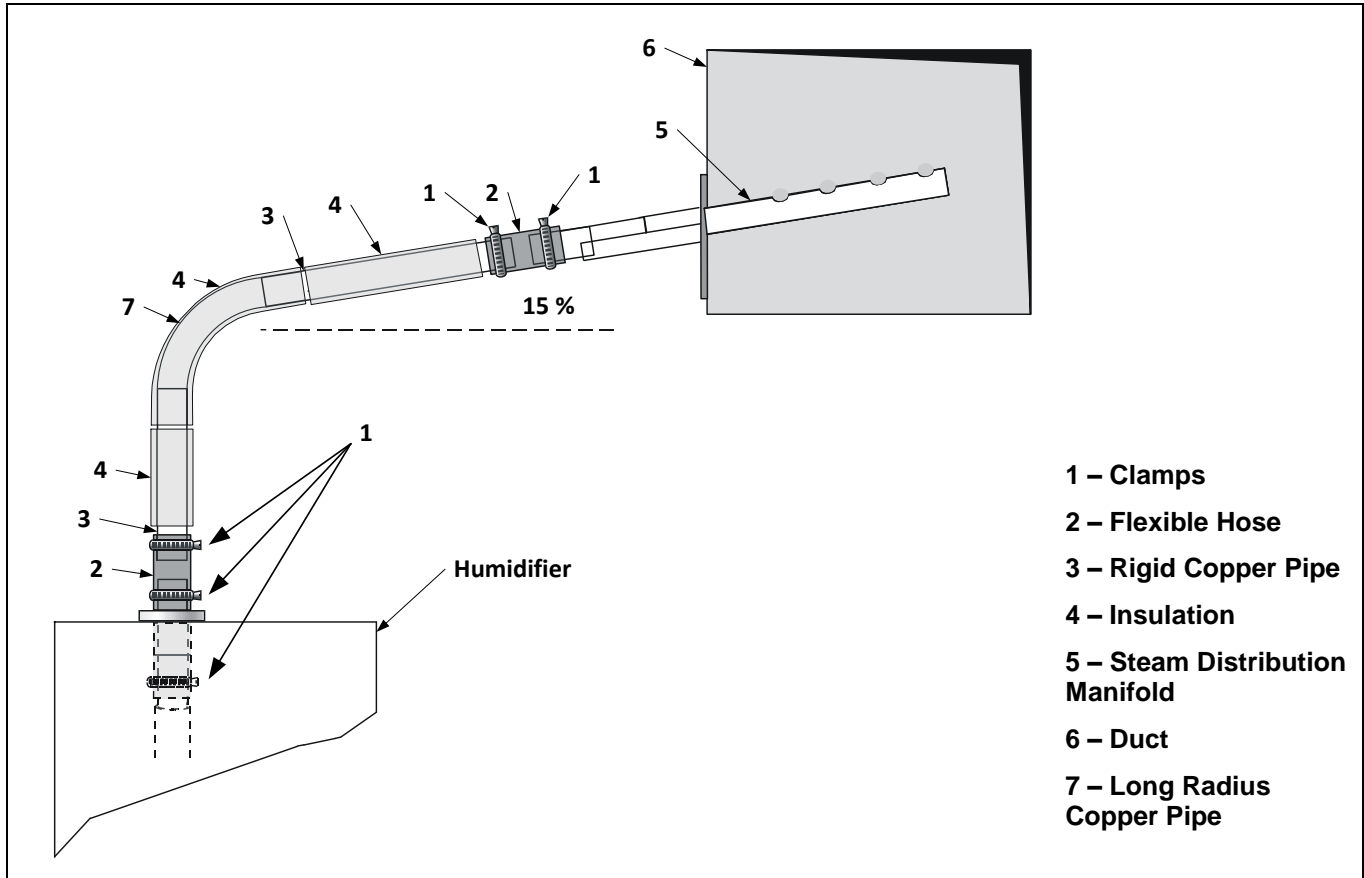

Illustration 23 - Steam Output Connections: Typical Installation

General Recommendations

Follow these general installation rules in order to avoid any restrictions inside the distribution pipes and the humidifier evaporation chamber, as well as condensation accumulation, which can lead to severe water accumulation in the duct or a humidifier malfunction.



CAUTION: Risk of malfunction. Avoid kinks, sags and areas where condensate can be trapped.

- Ensure that the slope of the steam hose (rigid or flexible) is not less than 15% (7 horizontal lengths for 1 vertical length), in order to ensure continuous drainage of condensation back to the humidifier or to a steam trap.
- Use flexible steam hoses for short runs (up to 16 feet or 5 m) or for interconnecting between the rigid pipe runs. Ensure that there are no kinks and that the hose does not sag when using flexible tubing. Do not use flexible hoses for curved portions of the steam line.
- Determine the total steam line for insulated hard piping based on the capacity of the humidifier, such as one equivalent foot for each lb/hr capacity of the humidifier (0.67 m for each kg/hr) with a maximum of 50 feet (15 m). Consult factory for longer steam line runs.
- If you are using a rigid copper pipe, use insulation to diminish condensate build-up.



S Trap Installation on the Steam Line

- The lowest point of any steam hose or rigid pipe must be the humidifier. If the humidifier cannot be the lowest point of the piping, install one or more steam traps (S Type) at the lowest point(s) of the steam supply piping. The steam separator (S trap) must be installed higher than the static pressure of the system by at least 2" (51 mm).

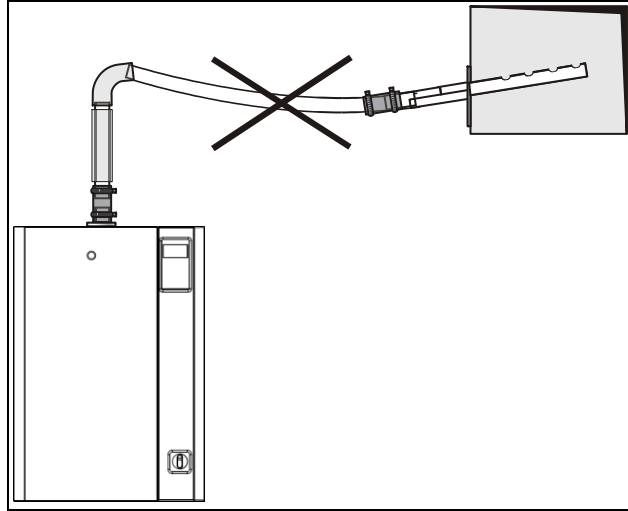

Illustration 24 - Steam Output Connection: Incorrect Installation

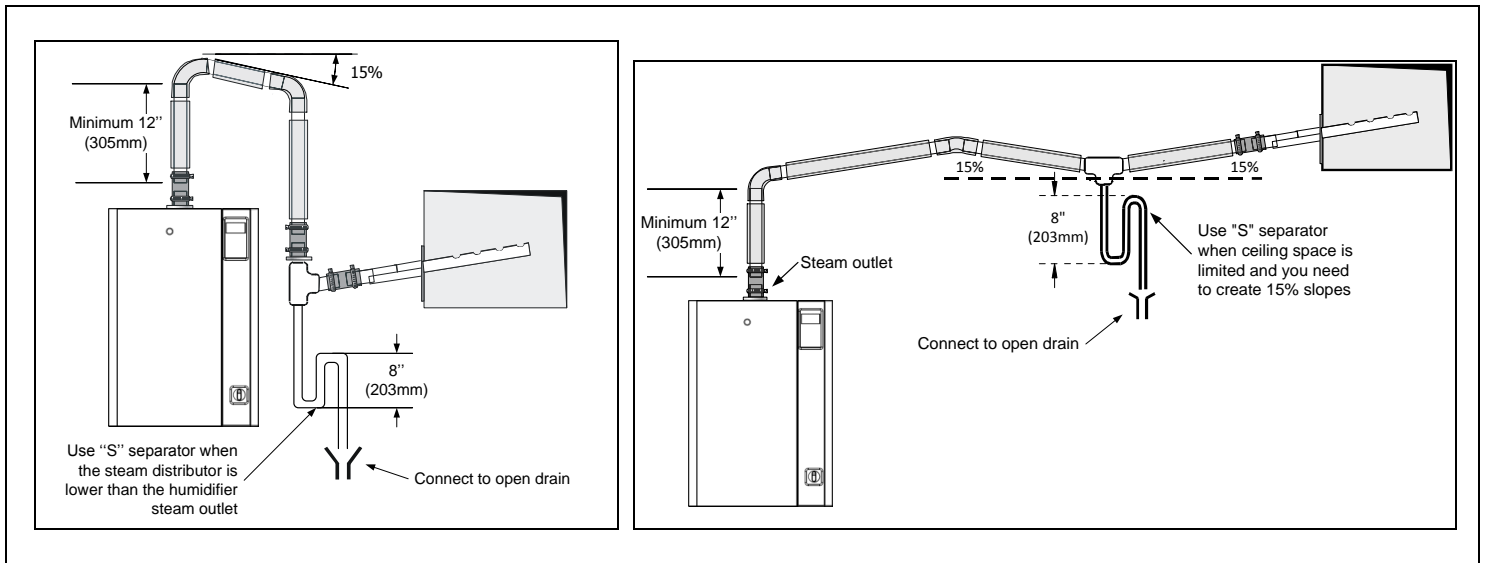
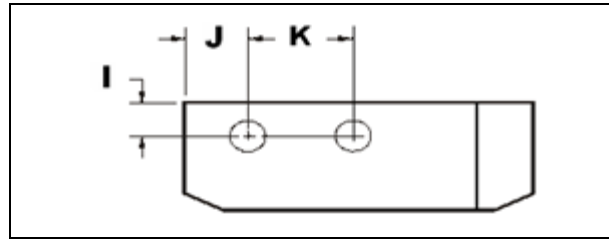
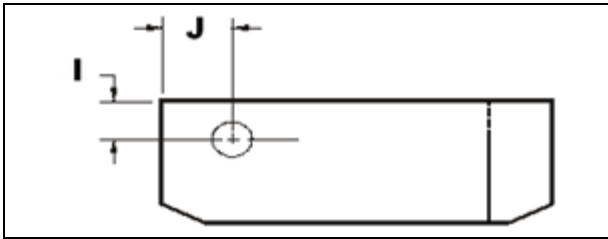

Illustration 25 - Steam Separator (S trap) Installation

Position of Steam Outputs

Table 7 - Position of Steam Outputs

Model	I	J	K
SKE4-N02 SKE4-N04 SKE4-N06	6 ¾" (171 mm)	9 ⅛" (232 mm)	-
SKE4-N10 SKE4-N14 SKE4-N16 SKE4-N20 SKE4-N30	7 ½" (191 mm)	12" (305 mm)	-
SKE4-N20 L SKE4-N40 SKE4-N50 SKE4-N60	7 ½" (191 mm)	23" (584 mm)	-
SKE4-N30 X SKE4-N40 X SKE4-N70	10 ½" (267 mm)	18" (457 mm)	-
SKE4-N80 SKE4-N90	10 ½" (267 mm)	8 ¾" (222 mm)	9.2" (234 mm)





Remote Installation - Humidifier with SDU

The SDU can be installed in a different location than the humidifier (remote SDU). Follow the piping recommendations.

- Mount the SDU to the wall on brackets (not supplied). Do not drill mounting holes through the cabinet of the SDU.
- Connect the steam hose to the bottom inlet of the SDU and to the humidifier steam outlet located on top of the cabinet.
- Secure the steam hose with the hose clamp (supplied).
- Connect the condensate hose to the bottom of the SDU and to an open drain or to the humidifier using the knockout hole located on the back of the cabinet.
- Connect the electrical wires from the SDU to the top of the humidifier. Field wiring must conform to local codes.
- The fan of the SDU will operate for a period of five minutes after steam production has stopped to prevent condensation.
- Avoid any obstruction of the ventilation openings on top of the SDU.

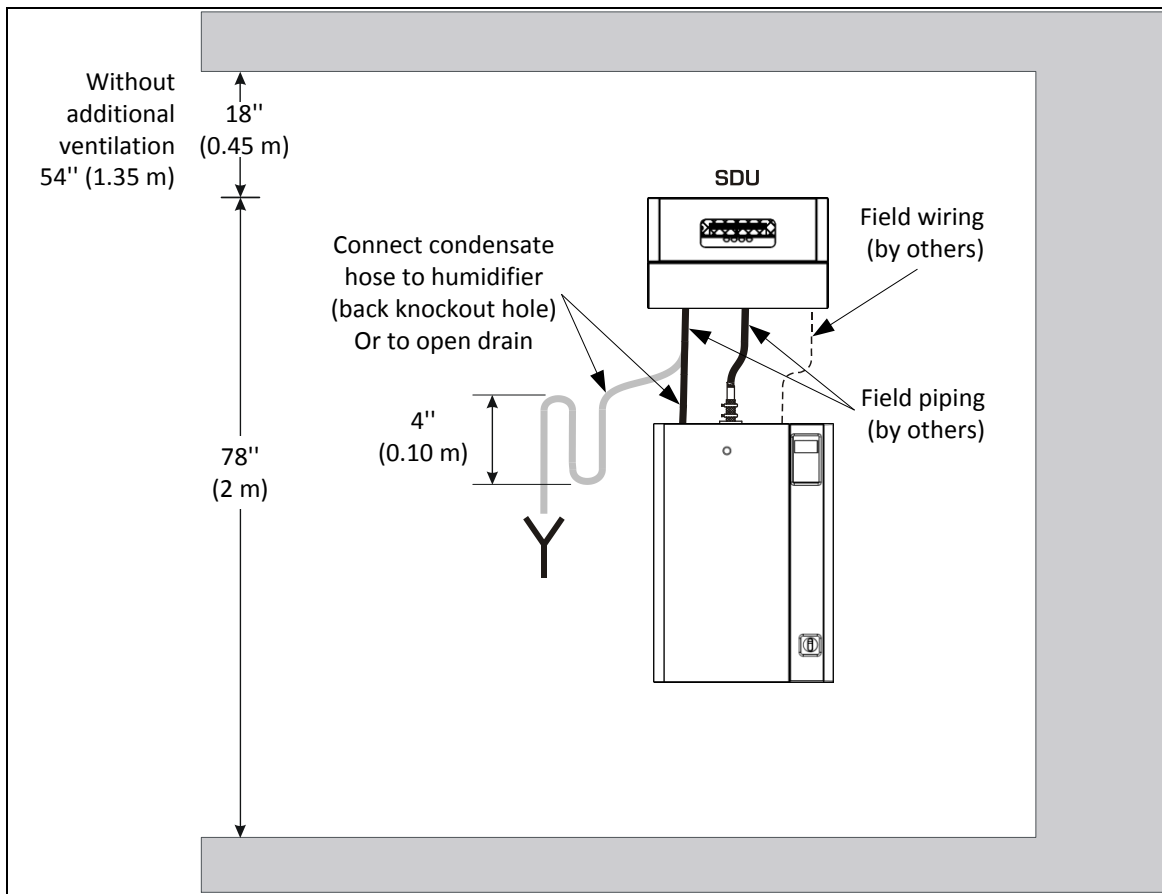

Illustration 26 - SDU Remote Installation



Plumbing Connections



**Plumbing Installation must conform to Local and National Codes.
Any installation work must be carried out by suitably qualified personnel.**

The SKE4 humidifier can operate with soft or hard water. For normal operation, pre-treatment of water is not necessary.

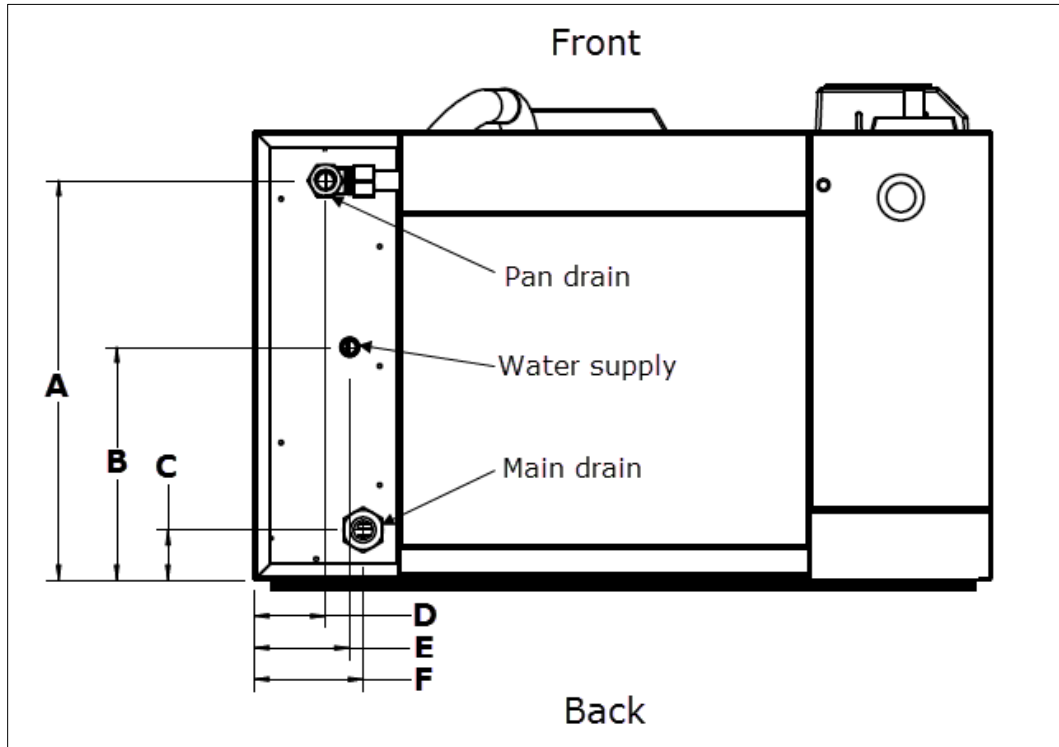

Illustration 27 - Plumbing Connections for Models SKE4-N02 to SKE4-N60 (Bottom View)

Table 8 - Dimensions for Plumbing Connections (SKE4-N02 to SKE4-N60)

Model	Dimensions (inch) [mm]					
	A	B	C	D	E	F
SKE4-N02 SKE4-N04 SKE4-N06	10 5/8 [270]	7 [178]	1 1/2 [38]	2 [51]	2 7/8 [73]	3 1/4 [83]
SKE4-N10 SKE4-N14 SKE4-N16 SKE4-N20 SKE4-N30 SKE4-N20 L SKE4-N40 SKE4-N50 SKE4-N60	12 [304]	7 [178]	1 1/2 [38]	2 [51]	2 7/8 [73]	3 1/4 [83]

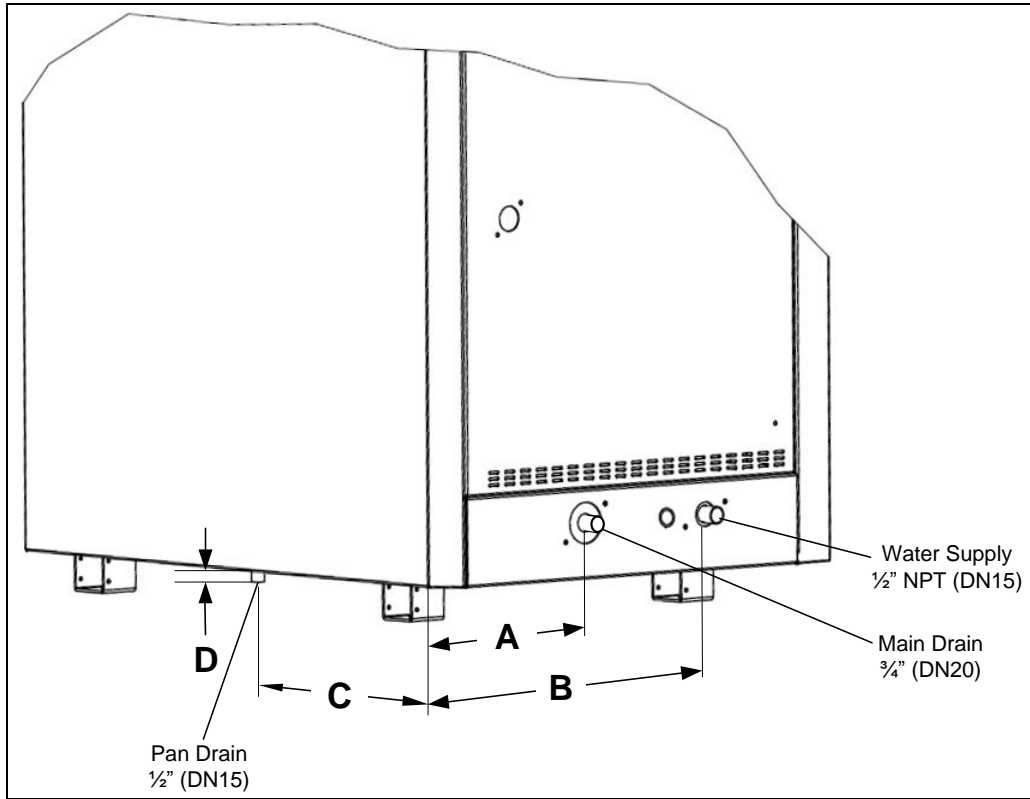

Illustration 28 - Plumbing Connections for Models SKE4-N30X to SKE4-N90

Table 9 - Dimensions for Plumbing Connections (SKE4-N30X to SKE4-N90)

Model	Dimensions (inch) [mm]			
	A	B	C	D
SKE4-N30 X	9 [229]	16 ⁵ / ₈ [422]	19 ⁵ / ₈ [498]	1/2 [13]
SKE4-N40 X				
SKE4-N70				
SKE4-N80				
SKE4-N90				



Note: For models SKE4-N30 X to SKE4-N90, the water supply inlet and main drain outlet are located on the right hand side of the humidifier by default. Left hand side or bottom placement (only with weather proof enclosure option) are available upon request.



Water Supply Connections

- Water Inlet Specifications:
 - Inlet water pressure: 10 to 70 psig (0.7 to 4.8 bars)
 - Maximum temperature: 86°F (30°C)
 - ½" (DN15) standard copper water line connection or ¾" (DN20) PEX pipe line
- Water Supply Line Installation:
 1. Connect a ½" (DN15) water supply braided hose (by others) to the bottom of the ½" (DN15) NPT fitting (supplied).
 2. Connect the top of the ½" (DN15) NPT fitting to the male threaded part of the pipe.
- In order to facilitate servicing, install a shutoff valve (not supplied) in the water supply line close to the humidifier.
- It is recommended to install a standard water strainer in the water supply line.
- It is recommended to install a water hammer arrestor, in order to absorb hydraulic shock and minimize water hammer when the fill valve closes.

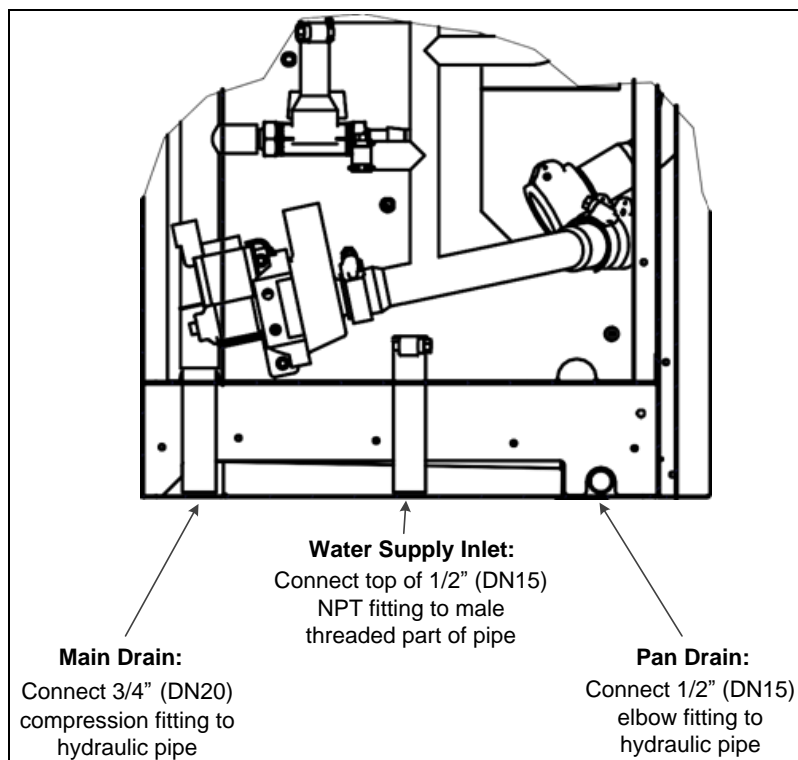

Illustration 29 - Water Supply and Drain Connections



Water Drain Connections

- Water Drain Specifications:
 - Evaporation chamber water drain temperature: 140°F (60°C).
 - Standard hydraulic fittings (supplied): a ¾" (DN20) female compression fitting for the evaporation chamber drain and a ½" (DN15) female elbow fitting for the pan drain.
- 2 hydraulic pipes (not supplied) must be placed underneath the humidifier and connected to the drain pipes (see Illustration 29 - Water Supply and Drain Connections).
- Use ¾" (DN20) and ½" (DN15) standard copper hydraulic pipes.
- Ensure that the drain pipe dimension is sufficient, especially if more than one humidifier is evacuating into the same drain line.
- The minimum drain pipe gradient must be of ¼" (6.5mm) per foot (300mm).
- The humidifier drain pipes do not require a drain trap and must be piped to an open drain.
- The main drain pipe must have a minimum diameter of 1-½" (DN40).

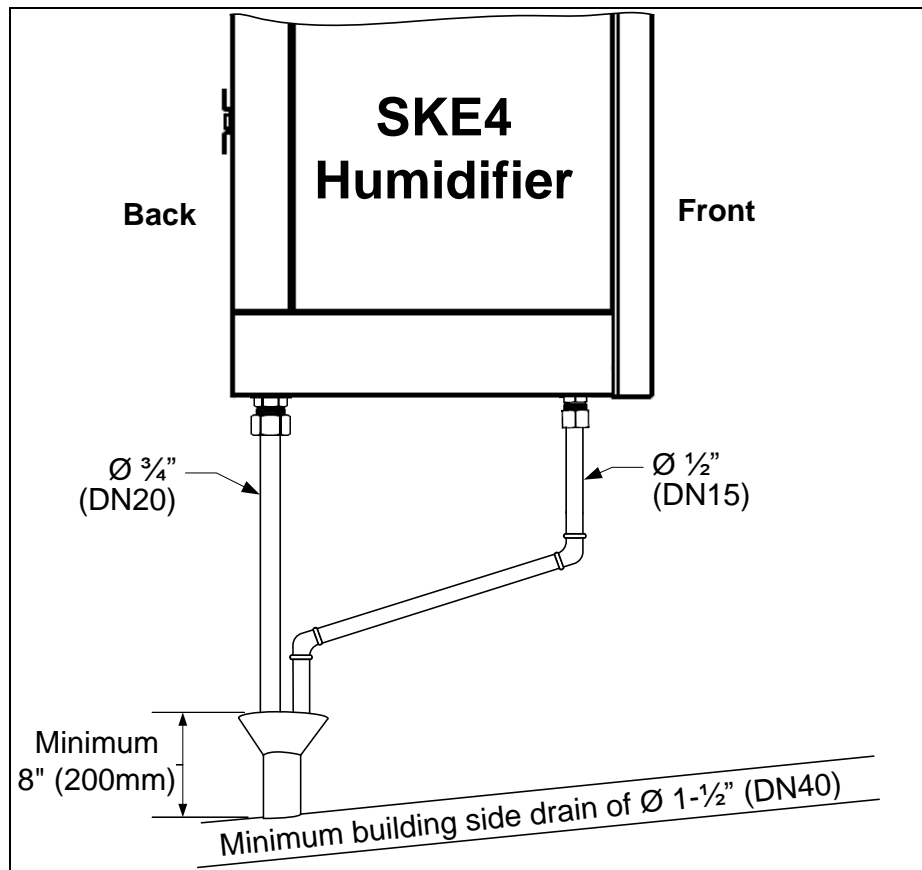

Illustration 30 - Plumbing Connection to Open Drain



Weather Proof Enclosure Plumbing Connection

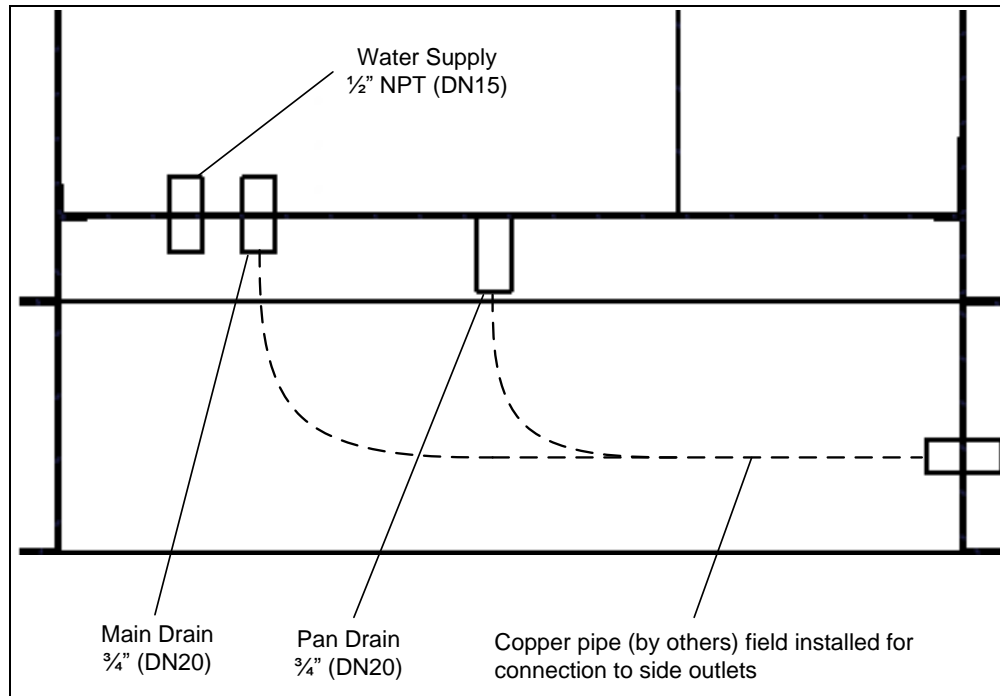

Illustration 31 - Weather Proof Enclosure Plumbing: Front View

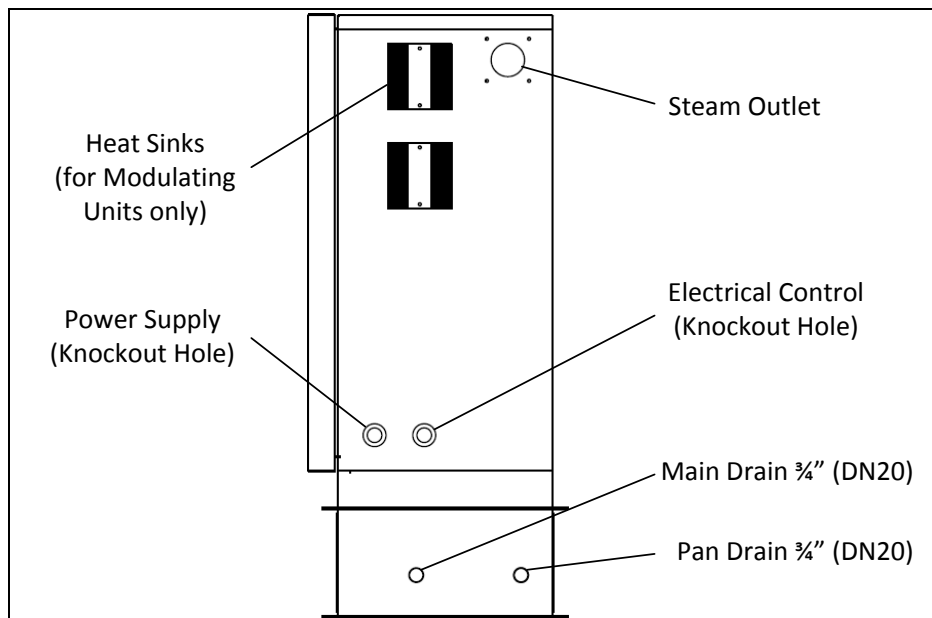

Illustration 32 - Weather Proof Enclosure Plumbing: Side View

Water Drain Valve

The weather proof enclosure is equipped with a normally open valve, enabling the humidifier to drain all water during a power failure, in order to prevent water from freezing within the unit. During normal operation, the humidifier reduces drain water temperature to 140°F (60°C).



CAUTION: During a power failure, the drain water temperature is not reduced. Installed drain piping must be rated to 212°F (100°C).



Electrical Connections



CAUTION: Risk of electric shock. Disconnect the humidifier from the electric supply before proceeding with the connection.



WARNING: Risk of fire. Do not interchange the power terminal block designated L1, L2 and L3 with low voltage terminal block designated 1, 2 and 3.

- The wiring to the humidifier must be done by a qualified electrician and must conform to the procedure, regulation and local codes.
- Use copper conductors only.
- An external over current protection and a disconnecting circuit breaker must be installed on the supply, adjacent to the humidifier.
- To provide strain relief to the supply cable, install a knock-out (not supplied) at the bottom of the electrical compartment of the humidifier.
- Ensure that the size of the wire conductors is appropriate for the current supplied.
- Ensure that each terminal connection is properly secured.
- Ensure that the ground conductor is equipped with a ring terminal and is connected directly to the electrical panel.

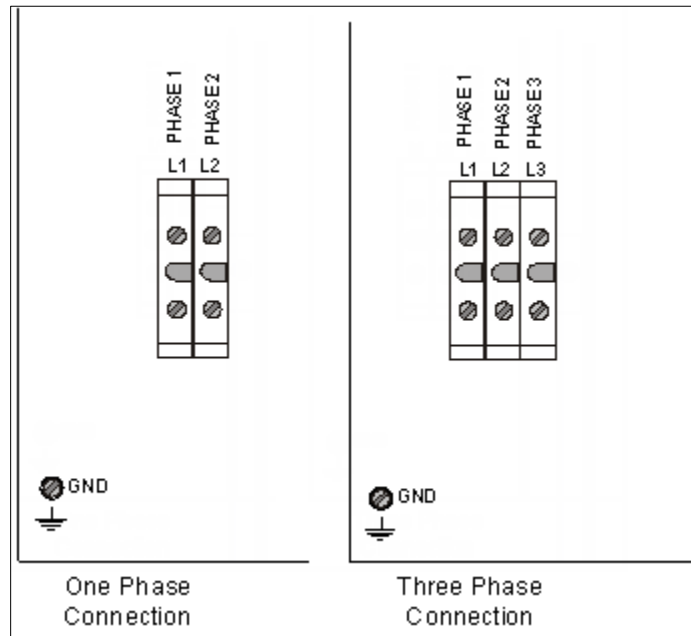

Illustration 33 - One and Three Phase Power Connections

Low Voltage Control Connections

Printed Circuit Board

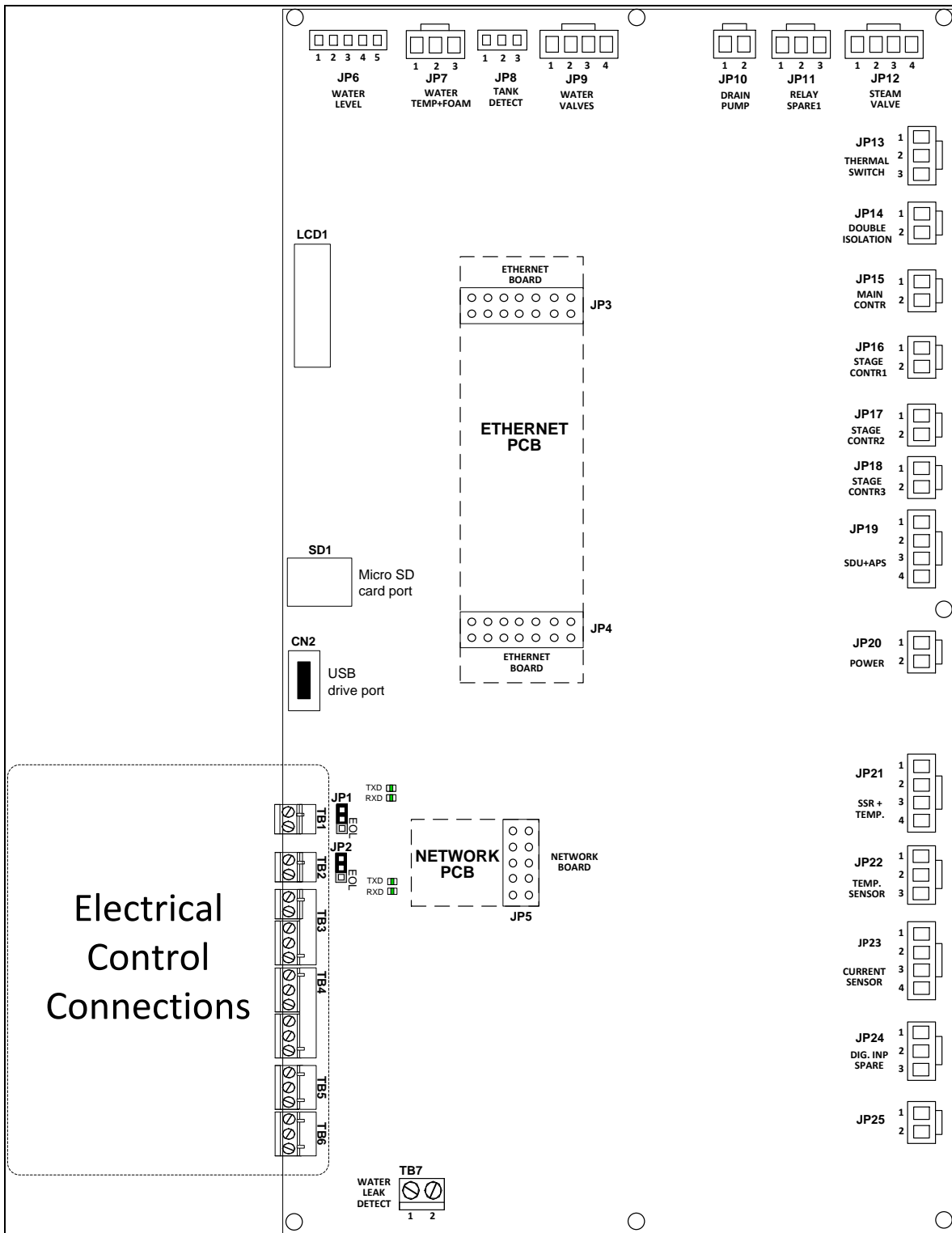

Illustration 34 - Printed Circuit Board Interface

The Printed Circuit Board (PCB) of the SKE4 Steam Humidifier is equipped with an advanced microprocessor, which controls all of the functions of the humidifier. All electrical control connections have been grouped alongside the bottom left corner of the PCB.

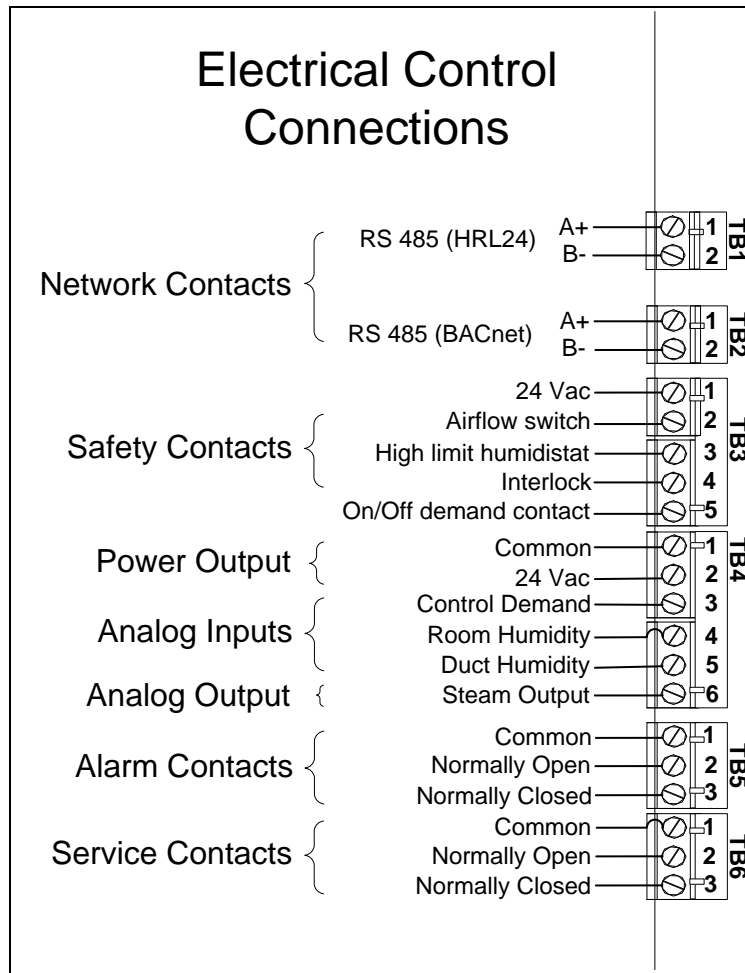

Illustration 35 - Electrical Control Connections

Safety Contact Connections

The **Airflow switch** contact must be wired between terminals TB3 1&2. If this contact opens, operation of the SKE4 unit will stop. The unit will display the airflow switch as open, but will not generate an alarm. If an airflow switch is not used, install a jumper between terminals TB3 1&2.

The **High limit humidistat** contact must be wired between terminals TB3 1&3. If this contact opens, operation of the SKE4 unit will stop and an **alarm** message will be displayed. If a high limit humidistat is not used, install a jumper between terminals TB3 1&3.

The **Interlock** must be wired between terminals TB3 1&4. If this contact opens, operation of the SKE4 unit will stop. The unit will display the Interlock as open, but will not generate an alarm. If Interlock is not used, install a jumper between terminals TB3 1&4.

Dry Contacts

Two series of volt free contacts are provided:

1. Alarm Contacts
2. Service Contacts

- These contacts are used to switch a low voltage, ideally 24V, with a switching current of no more than 3 Amps.
- Each series has one Normally Closed contact and one Normally Open contact.
- It is recommended to use the Normally Closed contact, as this contact will open in the event of a humidifier fault.

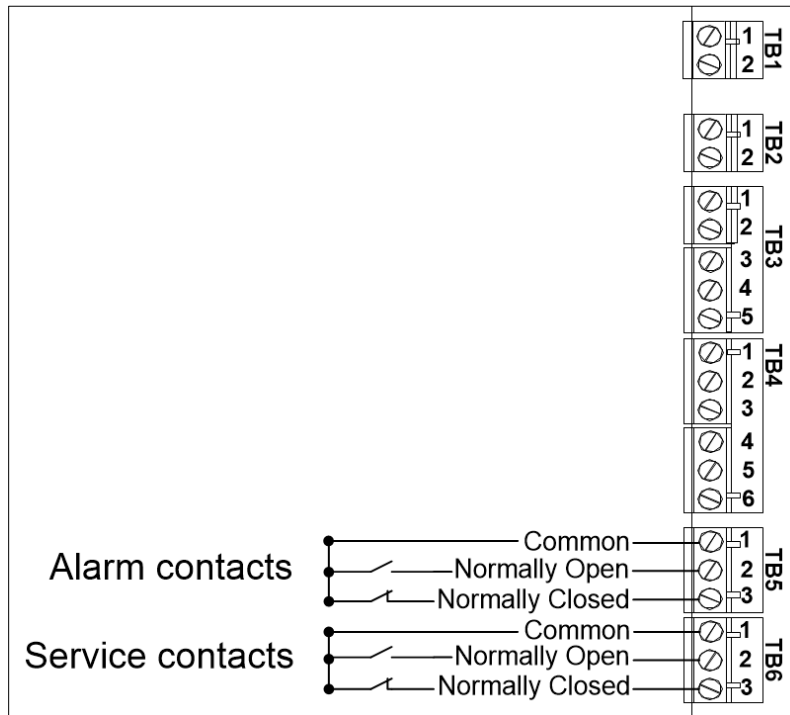

Illustration 36 - Alarm and Service Contact Wiring

ON/OFF Humidifier

For operation of On/Off humidifiers, connect the On/Off demand contact between TB3 1&5. If this contact opens, the SKE4 unit will turn off. If this contact closes, the SKE4 unit will operate.

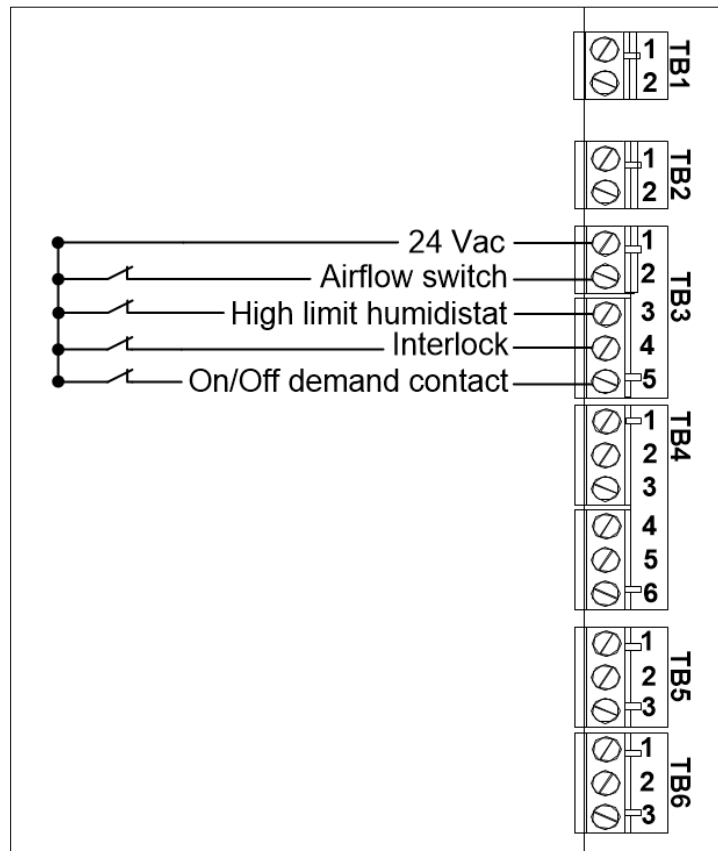

Illustration 37 - On/Off Humidifier Typical Wiring

Modulating Humidifier

Analog Signals

For operation of modulating humidifiers, the analog signal(s) must be connected between terminals TB4 1 and TB4 3, 4 and/or 5. To configure the source of the signal(s), access the *Control* sub-menu located in the *Installation* menu (see page 45).

Humidity Control by Humidistat (External Mode)

Humidity controlled externally, using HRO20 humidistat:

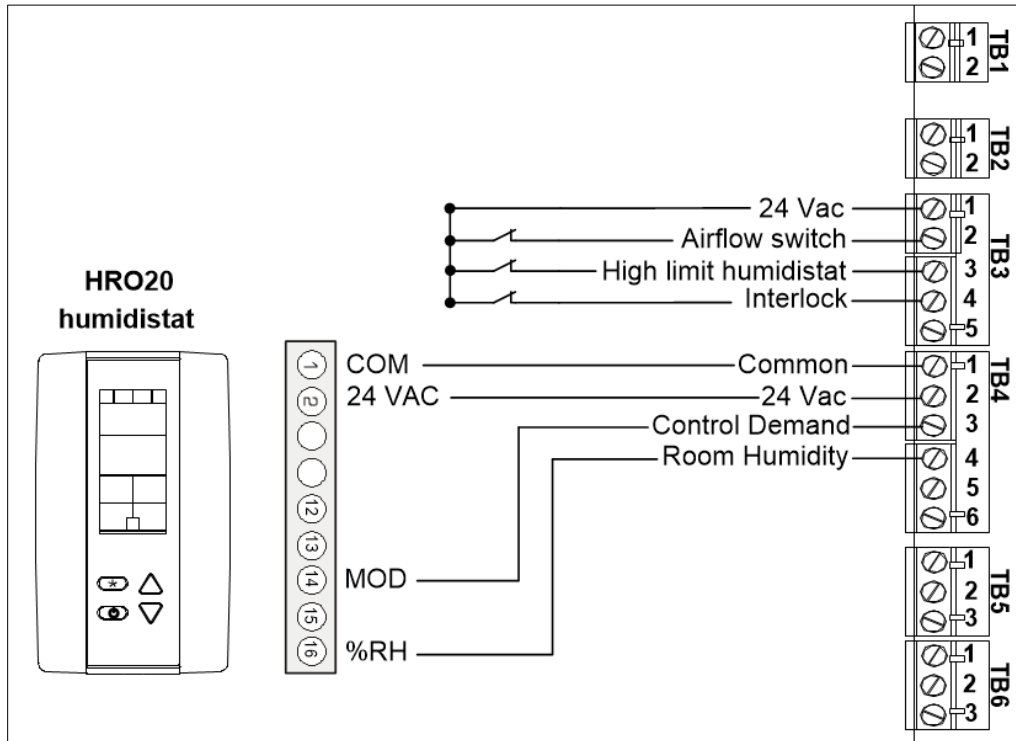

Illustration 38 - Control Signal from HRO20 Humidistat

Humidity controlled externally, using HRO20 humidistat with SHR10 or SHC80 as space sensor:

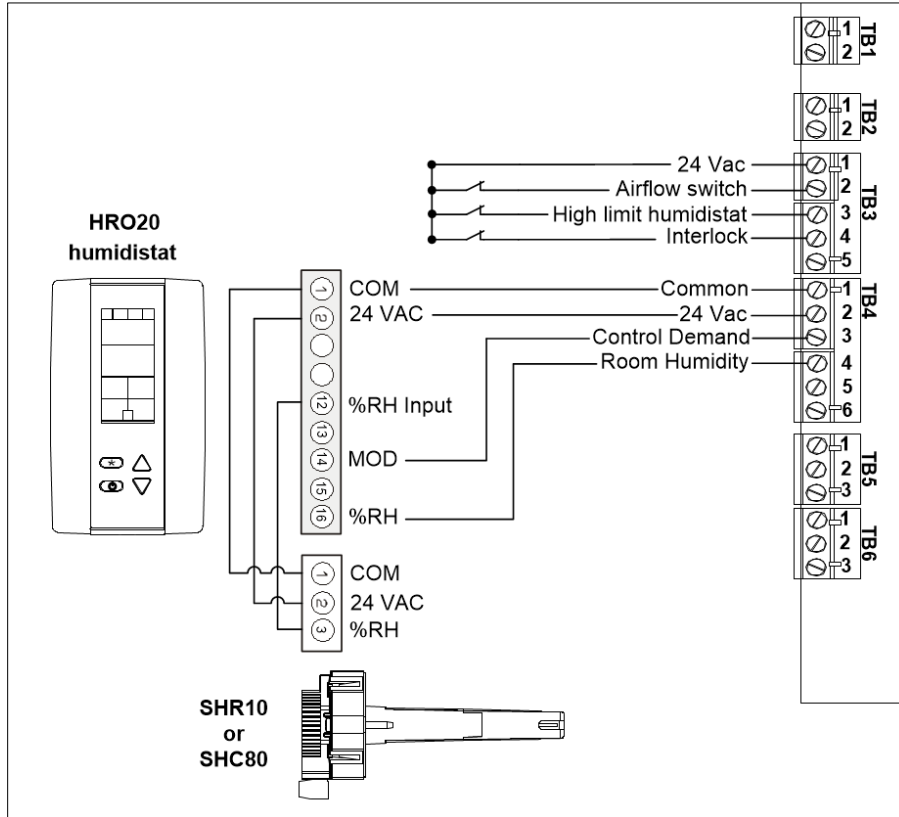

Illustration 39 - Control Signal from HRO20 Humidistat with Remote Humidity Sensor (SHR10 or SHC80)

Humidity Control by Humidifier (Internal Mode)

Humidity controlled internally, using SHR10 or SHC80 as space sensor:

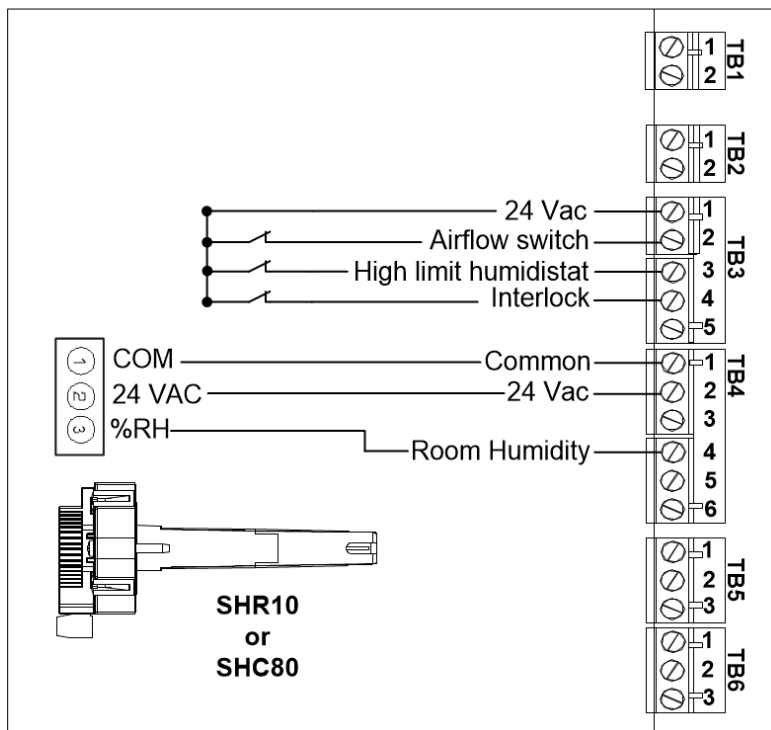

Illustration 40 - Humidity Signal from Remote Humidity Sensor (SHR10 or SHC80)

Network Communication

If the control signal is from a BACnet network, connect terminals TB2 1&2 to the network (RS485 A+ & B-).

If the control signal is from a HRL24, connect terminals TB1 1&2 to the network (RS485 A+ & B-).

The network control signal(s) must be selected by accessing the *Control* sub-menu located in the *Installation* menu (see page 45). To setup the communication parameters, access the *Integration* menu (see page 47).

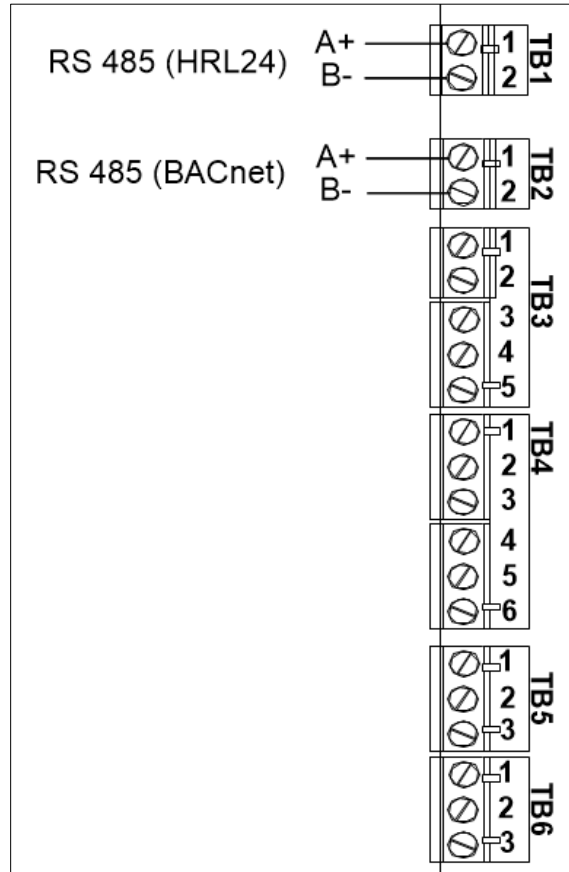

Illustration 41 - Network Communication Connections

Controls Placement (Steam Dispersed into a Duct or AHU)

A typical humidifier control system includes the following along with the humidifier:

- A wall or return duct humidistat
- A high limit duct humidistat
- An airflow switch

Placement of these devices is critical to the proper operation of the overall system.

- The return air humidistat must always be located in the return air duct, in order to ensure accurate sensing of the air from the humidified space.
- Alternatively, a room humidistat can be used. The room humidistat must be located on an inside wall or column. It must not be near any discharge air from supply ducts or sources of heat or cold.
- The airflow switch must be placed in a position capable of accurately opening on a loss of air flow, in order to prevent the humidifier from running when there is no air to absorb humidity.
- The high limit humidistat must be positioned far enough, minimum 15 ft (4.6 m), downstream of the steam dispersion manifold(s) to prevent over humidification of the duct that could result in condensation.

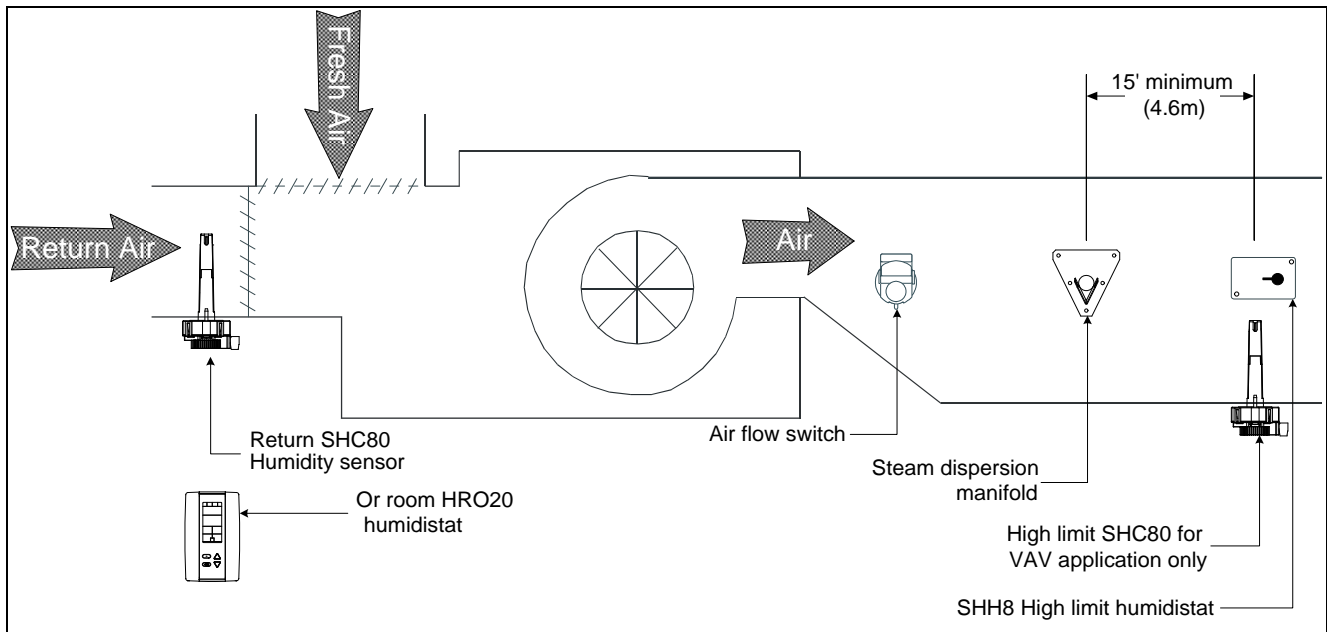

Illustration 42 - Controls Placement (Steam Dispersed into a Duct or AHU)

Controller Configuration

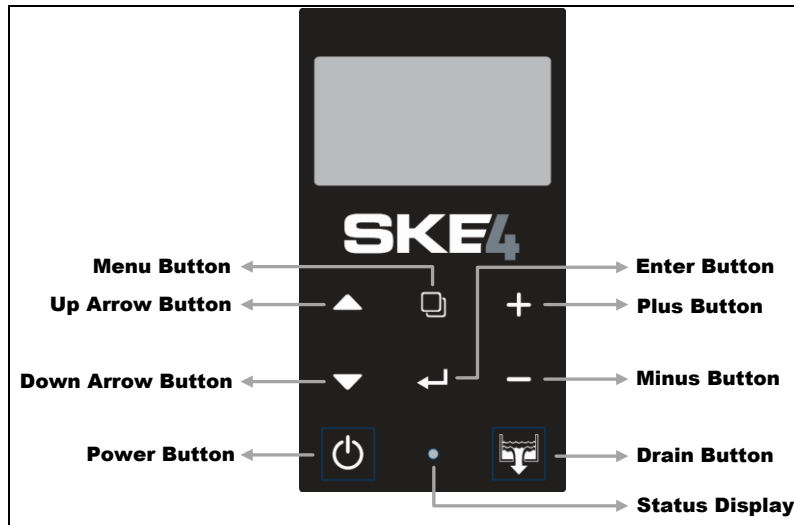













Illustration 43 - SKE4 Controller

Control Panel Features

The following are the features of the Control Panel and their description:

Table 10 - Humidifier Control Panel Description

Feature		Description
Status Display	 (Blue)	Indicates that the humidifier is turned on. The LED will begin blinking as the system is initializing.
	 (Red)	Indicates that the alarm is issuing a warning and that the system must be verified.
	 (Off)	Indicates that the humidifier is turned off.
Power Button		The power button is used to turn the humidifier on or off. Must be pressed and held for 3 seconds to perform the related action, in order to prevent accidental activation. Even when the humidifier is powered off, the controller remains operational.
Drain Button		The drain button is used to manually activate the drain cycle. Must be pressed and held for 3 seconds to perform the related action, in order to prevent accidental activation. Even when the humidifier is powered off, a drain cycle may be initiated. <i>Once the manual drain cycle is completed, the system will automatically be powered off. To turn the humidifier back on, press and hold the power button.</i>
Up and Down Arrow Buttons		The up arrow button is used to scroll to the next menu item or parameter.
		The down arrow button is used to scroll to the previous menu item or parameter.
Plus and Minus Buttons		The plus button is used to increase the value of the displayed parameter.
		The minus button is used to decrease the value of the displayed parameter.
Menu Button		The menu button is used to go to previous menu or to access the Main Menu page from the Idle Screen.
Enter Button		The enter button is used to advance to the next sub-menu, to access the selected option or to confirm set parameter value.

Idle Screen

When the controller is in operation, the unit displays the following information on the Idle Screen:

Table 11 - Idle Screen Display Description

Setting	Default	Range (* indicates no configuration; display only)	Description/Notes
HumDemand:	Current value	* (min: 0.00%, max: 100.00%)	Displays the current humidity demand value.
ControlState:	Current value	* (Off, Normal, LowLimit, HighLimit, NoAirFlow, Interlock)	Displays the current state of the safety control circuit and whether the circuit has been disconnected due to a safety switch.
PowerOutput:	Current value	* (min: 0.00%, max: 100.00%)	Displays the measured power output of the system as a percentage of the total power.
State:	Current value	* (Off, Idle, LineRinse, TankRinse, Filling, Draining, Heating, Boiling, Alarm)	Displays the current state of operation of the humidifier.

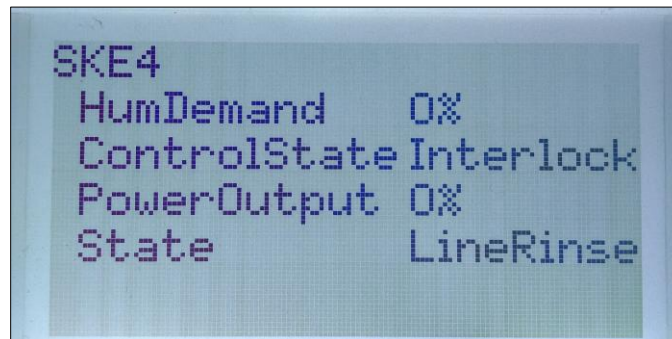

Illustration 44 - Idle Screen Display

Menu Access

- From the Idle Screen, the Main Menu can be accessed by pressing the Menu button , enabling access to the General menu.
- To view other menu options and perform configurations to the system, press Enter ↵ while on the Idle Screen to advance to the Login Screen, where a valid password must be entered.
- Four different passwords can be used, each granting access to an additional menu option depending on the access level assigned to the provided password.
- If a password of higher access is provided, all menu options accessible with the use of a lower level password will also be unlocked.

Table 12 - Access Levels

Access Level	Password	Menu Unlocked	Description/Notes
1	None	General	Grants access to General menu.
2	2222	User	Grants access to General and User menus.
3	3322	Service	Grants access to General, User and Service menus.
4	4433	Installation	Grants access to General, User, Service and Installation menus.
5	5544	Integration	Grants access to General, User, Service, Installation and Integration menus.

Note: To modify or retrieve lost passwords, please contact factory.





- A. After accessing the Login Screen, use the + or - buttons to increase or decrease the value of the number that is highlighted.
- B. Use the ▲, ▼ buttons to scroll to the next or previous number.
- C. Press Enter ↵ to confirm the password once completed. If you enter the wrong password, the SKE4 controller displays a "Login Failed" message.
- D. The Menu button  may also be used to return to the Idle Screen display.



Illustration 45 - Login Screen

Menu Navigation and Configuration

- A. Use the ▲, ▼ buttons to select the desired menu category and press Enter ↵ to advance to the next sub-menu.
- B. Use the + and - buttons to increase and decrease values. Use the ▲, ▼ buttons to scroll to the next or previous parameter. Values are saved as soon as a change is made.
- C. Press the Menu button  to go back one menu. The current menu location is displayed at the top of the screen.
- D. To exit completely, press the Menu button  until you return to the Idle Screen. After 5 minutes of inactivity, the controller will automatically return to the Idle Screen.

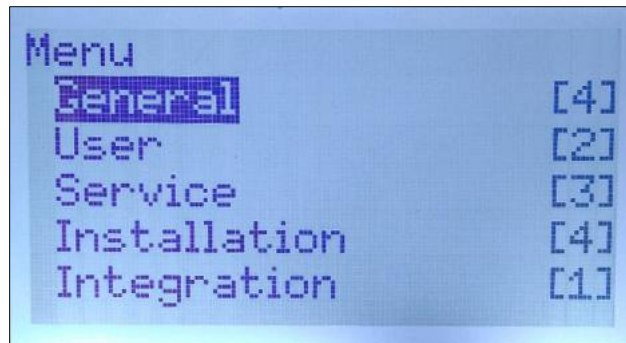

Illustration 46 - Main Menu Page

Note: Available settings and range selections may vary depending on current configuration. The tables in the following sections display all the possible selections. The Description/Notes column indicates the conditions required for the associated setting to appear.

Menu - General [Level 1 - No password required]

Press the menu button from the Idle Screen to access the General menu.

Sub-Menu	Setting	Default	Range (* indicates no configuration; display only)	Description/Notes
Status	AirFlow:	Closed	* (Closed, Open)	Displays the status of the airflow switch. If <i>Open</i> is displayed, it indicates that the airflow is not detected by the air pressure switch.
	SupplyHighLimit:	Closed	* (Closed, Open)	Displays the status of the high limit contact. If <i>Open</i> is displayed, it indicates that the humidity level has exceeded the setpoint on the high limit humidistat.
	Interlock:	Closed	* (Closed, Open)	Displays the status of the interlock. If <i>Open</i> is displayed, it indicates that the humidifier is stopped as a result of the interlock safety being open.
	OccupancyState:	<i>Current value</i>	* (Occupied, Unoccupied, Vacant, Off)	Displays the current occupancy state. (Only appears if <i>ControlProfile</i> is set to an internal control mode or <i>HumCntrlDemandSrc</i> is set to <i>RoomDemand</i>.)
	BoilerDemand:	<i>Current value</i>	* (min: 0.00%, max: 100.00%)	Displays the measured humidity demand of the humidifier.
	PowerOutput:	<i>Current value</i>	* (min: 0.00%, max: 100.00%)	Displays the measured power output of the system as a percentage of the total power.
	ServiceDue:	Off	* (Off, On)	Displays whether the humidifier is due for servicing.
	State:	<i>Current value</i>	* (Off, Idle, LineRinse, TankRinse, Filling, Draining, Heating, Boiling, Alarm)	Displays the current state of operation of the humidifier.
Control	RoomDemand:	<i>Current value</i>	* (min: 0.00%, max: 100.00%)	Displays the room humidity demand value. (Only appears if <i>ControlProfile</i> is set to an internal control mode or <i>HumCntrlDemandSrc</i> is set to <i>RoomDemand</i>.)
	SupplyHLDemand:	<i>Current value</i>	* (min: 0.00%, max: 100.00%)	Displays the supply high limit humidity demand value. (Only appears if <i>ModHLProfile</i> is set to an internal control mode or <i>HumCntrlHLSrc</i> is set to <i>SupplyHLDemand</i>.)
	HumDemand:	<i>Current value</i>	* (min: 0.00%, max: 100.00%)	Displays the current humidity demand value.
	ControlState:	<i>Current value</i>	* (Off, Normal, LowLimit, HighLimit, NoAirFlow, Interlock)	Displays the current state of the safety control circuit and whether the circuit has been disconnected due to a safety switch.
Physical IO	AirFlow:	Closed	* (Closed, Open)	Displays the status of the airflow switch. If <i>Open</i> is displayed, it indicates that the airflow is not detected by the air pressure switch.
	SupplyHighLimit:	Closed	* (Closed, Open)	Displays the status of the high limit contact. If <i>Open</i> is displayed, it indicates that the humidity level has exceeded the setpoint on the high limit humidistat.
	Interlock:	Closed	* (Closed, Open)	Displays the status of the interlock. If <i>Open</i> is displayed, it indicates that the humidifier is stopped as a result of the interlock safety being open.
	BinExtDemand:	0%	* (0%, 100%)	Displays whether there is currently a humidity demand, when an On/Off humidifier is used. (Only appears when using an On/Off humidifier.)
	ControllInput:	<i>Current value</i>	* (min: 0.00%, max: 100.00%)	Displays the current control input reading.
	RoomRH:	<i>Current value</i>	* (min: 0.00%, max: 100.00%)	Displays the room humidity reading value. (Only appears if <i>ControlProfile</i> is set to <i>InternAnalog</i> or <i>RoomRHSrc</i> is set to <i>RoomRH</i>.)
	SupplyHLRH:	<i>Current value</i>	* (min: 0.00%, max: 100.00%)	Displays the supply high limit humidity reading value. (Only appears if <i>ModHLProfile</i> is set to <i>InternAnalog</i> or <i>SupplyHLReadingSrc</i> is set to <i>SupplyHLRH</i>.)
	WtrLeakDet:	Ok	* (Ok, Leak)	Displays whether a water leak has been detected. If <i>Leak</i> is displayed, it indicates that there is a leak within the water line.
	WtrLvlLow:	<i>Current value</i>	* (Inactive, Active)	Displays the status of the resistive low water level sensor.
	WtrLvlHigh:	<i>Current value</i>	* (Inactive, Active)	Displays the status of the resistive high water level sensor.

Sub-Menu	Setting	Default	Range <i>(* indicates no configuration; display only)</i>	Description/Notes
Physical IO	WaterTemp:	<i>Current value</i>	* (min: 32.00°F, max: 257.00°F) * [min: 0.0°C, max: 125.0°C] Units: C, F	Displays the temperature of water in the evaporation chamber.
	FoamSensor:	NoFoam	* (NoFoam, Foam)	Displays whether foam has been detected within the evaporation chamber. If <i>Foam</i> is displayed, it indicates that the Anti-Foaming Energy Conservation (AFEC) system has detected foam. The humidifier will drain for a few minutes and return to normal operation.
	ThermalCutout:	Closed	* (Closed, Open)	Displays the status of the high temperature switch. If <i>Open</i> is displayed, it indicates that an abnormal temperature has been sensed.
	SSRTemp:	<i>Current value</i>	* (min: -4.00°F, max: 212.00°F) * [min: -20.0°C, max: 100.0°C] Units: C, F	Displays the temperature measured on the solid-state relay.
	ContactorsFuse:	Normal	* (Normal, Blown Fuse)	Displays the current status of the PCB fuse. If <i>Blown Fuse</i> is displayed, the fuse must be replaced.
	PowerOutFdbck:	<i>Current value</i>	* (min: 0.00%, max: 100.00%)	Displays the feedback value of power output analog output.
	AlarmWarnRelay:	<i>Current value</i>	* (Off, On)	Displays the status of the alarm warning relay.
	ServiceWarnRelay:	<i>Current value</i>	* (Off, On)	Displays the status of the service warning relay.
	WtrLvlValve:	<i>Current value</i>	* (Off, On)	Displays the status of the water level sensor supply valve.
	TankWtrValve:	<i>Current value</i>	* (Off, On)	Displays the status of the evaporation chamber water supply valve.
	DrainCoolValve:	<i>Current value</i>	* (Off, On)	Displays the status of the internal drain cooler valve.
	DrainPump:	<i>Current value</i>	* (Off, On)	Displays the status of the drain pump.
	MainContactor:	<i>Current value</i>	* (Off, On)	Displays the status of the main contactor.
	HeaterStage1:	<i>Current value</i>	* (Off, On)	Displays the status of the first stage contactor. (Only appears based on humidifier model and configurations.)
	HeaterStage2:	<i>Current value</i>	* (Off, On)	Displays the status of the second stage contactor. (Only appears based on humidifier model and configurations.)
	HeaterStage3:	<i>Current value</i>	* (Off, On)	Displays the status of the third stage contactor. (Only appears based on humidifier model and configurations.)
	SDUFan:	<i>Current value</i>	* (Off, On)	Displays the status of the SDU fan. (Only appears for humidifiers having the SDU option.)
	HeaterSSRStage:	<i>Current value</i>	* (min: 0.00%, max: 100.00%)	Displays the heater vernier stage output value.
WaterLevel:	<i>Current value</i>	* (min: 0.0%, max: 120.0%)	Displays the percentage of water remaining in the evaporation chamber.	
System	SysStatus:	Operational	* (Operational, Operational Read-Only, Download required, Download in progress, Non-operational, Backup in progress)	Displays the current system status.
	Vendor:	Neptronic	*	Displays the name of the vendor of the product. (Always Neptronic)
	Model:	-	*	Displays the humidifier model name.
	FirmwareRev:	-	*	Displays the latest firmware revision.
	CoreVersion:	-	*	Displays the current application software version.
	SerialNo:	-	*	Displays the serial number of the humidifier.
	Profile:	-	*	Displays a short profile for the configured device.
	MCULoad:	<i>Current value</i>	* (min: 0.0%, max: 100.0%)	Displays the current microcontroller load.
	MemoryLoad:	<i>Current value</i>	* (min: 0.0%, max: 100.0%)	Displays the current memory load.
	ResetReason:	None	* (None, BOR, Pin, POR, Soft, IWDG, WWDG, LPWR, Unknown)	Displays the reason for the previous system reset: <i>None = No Reset; BOR = Brownout Reset; Pin = Pin Reset (using PCB Reset Button); POR = Power-on Reset; Soft = Software Reset; IWDG = Independent Watchdog; WWDG = Windowed Watchdog; LPWR = Low Power Reset; Unknown = Unknown Cause</i>

Menu - User [Level 2 - Requires level 2 (or higher) password in order to access]

Sub-Menu	Setting	Default	Range	Description/Notes
Command	OccupSchedule:	-	00:00 Monday to Sunday Event 1 to Event 6	Create a customized occupancy schedule with up to six events per day. (Only appears if ControlProfile is set to an internal control mode or HumCntrlDemandSrc is set to RoomDemand.)
Control	RoomDemandLoop [3]			Only appears if ControlProfile is set to an internal control mode or HumCntrlDemandSrc is set to RoomDemand.
	RoomRHStp:	40.00%	min: 0.00%, max: 100.00%	Define the room demand setpoint value used during <i>Occupied</i> state. (Only appears if RoomRHStpSrc is set to Internal.)
	RoomRHUnocStp:	30.00%	min: 0.00%, max: 100.00%	Define the room demand setpoint value used during <i>Unoccupied</i> state.
	RoomRHHvacStp:	20.00%	min: 0.00%, max: 100.00%	Define the room demand setpoint value used during <i>Vacant</i> state.
	SupplyHLLoop [1]			Only appears if ModHLProfile is set to an internal control mode or HumCntrlHLSrc is set to SupplyHLDemand.
	SupplyHLStp:	80.00%	min: 0.00%, max: 100.00%	Define the supply high limit demand setpoint value.
System	LocalDateTime:	YYYY-MM-DD 00:00:00		Configure the current date and time.
Interface	BacklightLvl:	25%	min: 0%, max: 100%	Select the backlight level of the LCD screen.
	Contrast:	10%	min: 0%, max: 30%	Select the contrast level of the LCD screen.
	KeypadBuzzer:	Inactive	Inactive, Active	Select whether to enable or disable the key press sound.
	Language:	English	<i>(Language options vary based on region.)</i>	Select the device language.
	Units:	Imperial	Metric, Imperial	Select whether to use a metric or imperial system of units for the local device.

Menu - Service [Level 3 - Requires level 3 (or higher) password in order to access]

Sub-Menu	Setting	Default	Range <i>(* indicates no configuration; display only)</i>	Description/Notes
Status	RunTime:	0.00hr	*	Displays the total runtime of the unit.
	OnTime:	0.00hr	*	Displays the total operating time of the unit.
	ServRunTime:	0.00hr	*	Displays the runtime of the unit, since the last servicing.
	ServOnTime:	0.00hr	*	Displays the operating time of the unit, since the last servicing.
	ServiceDue:	Off	* (Off, On)	Displays whether the humidifier is due for servicing.
Command	DrainSchedule:	-	00:00 Monday to Sunday Event 1 to Event 6	Create a customized draining schedule with up to six events per day.
	Request:	None	None, Reset Alarms, Drain, Reset Counters	Perform one of the following actions for the humidifier: reset service counters, initiate a drain cycle or reset warning alarms.
Extended Config	WaterProbeAutoCalib:	Always	None, Once, Always	Select the frequency of the auto calibration setting for the water level sensor.

Menu - Installation [Level 4 - Requires level 4 (or higher) password in order to access]

Sub-Menu	Setting	Default	Range	Description/Notes	
Quick Config	DrainInterval:	6hr	min: 0hr, max: 24hr	Set the frequency of the drain cycle. In general, a more frequent drain cycle is required as the water hardness level rises. The drain cycle setting does not affect the AFEC system.	
	IdleTime:	72hr	min: 24hr, max: 72hr	Set the amount of time the humidifier can remain in standby mode until an automatic drain cycle is performed.	
	BlowdownRate:	0%	min: 0.0%, max: 100%	Define the rate of boiler blowdown or water dilution, in order to minimize water impurities.	
	ServInterval:	1000hr	min: 1000hr, max: 3000hr	Set the time of operation before the humidifier calls for servicing.	
	ServOperation:	Allowed	Not Allowed, Allowed	Select whether to enable the unit to continue producing steam, even when it is due for servicing. When set to <i>Allowed</i> , the unit will continue operating even when a service alarm is active.	
	FillMode:	Pulsed	OneShot, Pulsed	Select the water filling method for the fill valve: When set to <i>OneShot</i> , water will continuously flow. When set to <i>Pulsed</i> , water will flow in short bursts.	
Control	ControlProfile:	ExternAnalog	ExternAnalog, ExternNetwork, InternAnalog, InternNetwork, InternTBD, Custom	Select a preconfigured control mode profile for the modulating humidity demand. Select the <i>Custom</i> option to configure individual settings. (Network option only applicable for BACnet models.)	
	ModHlProfile:	Disabled	Disabled, ExternAnalog, ExternNetwork, InternAnalog, InternNetwork, Custom	Select a preconfigured control mode profile for the modulating high limit demand. Select the <i>Custom</i> option to configure individual settings. (Network option only applicable for BACnet models.)	
	RoomDemandLoop [2]			Only appears if ControlProfile is set to an internal control mode or HumCntrlDemandSrc is set to RoomDemand.	
		RoomRHSrc:	None	None, RoomRH, Network	Select the reading source for the room demand. (Network option only applicable for BACnet models.)
		RoomRHStptSrc:	None	None, Internal, ControllInput	Select the room demand setpoint source.
	SupplyHlLoop [2]			Only appears if ModHlProfile is set to an internal control mode or HumCntrlHlSrc is set to SupplyHlDemand.	
		SupplyHlReadingSrc:	None	None, SupplyHlRH, Network	Select the reading source for the supply high limit demand. (Network option only applicable for BACnet models.)
		SupplyHlStpntSrc:	None	None, Internal, ControllInput	Select the supply high limit demand setpoint source.
	HumidityControl [2]				
		HumCntrlDemandSrc:	ControllInput	None, ControllInput, RoomDemand, Network	Select the humidity control demand source for modulating humidifiers. (Network option only applicable for BACnet models.)
	HumCntrlHlSrc:	None	None, ControllInput, SupplyHlDemand, Network	Select the humidity control high limit source for modulating humidifiers. (Network option only applicable for BACnet models.)	
	HumCntrlBinDemandSrc:	None	None, BinaryExtDemand	Select the humidity control demand source for On/Off humidifiers.	
Physical IO	AlwaysRoomRH:	Off	Off, On	Select whether to always display the <i>RoomRHSigType</i> setting, regardless of the configuration selected in the <i>ControlProfile</i> setting.	
	AlwaysSupplyRH:	Off	Off, On	Select whether to always display the <i>SupplyRHSigType</i> setting, regardless of the configuration selected in the <i>ModHlProfile</i> setting.	
	CntrlSigType:	0-10Vdc	0-10Vdc, 2-10Vdc, 4-20mA, 0-20mA	Select the signal type for the control demand analog input.	
	RoomRHSigType:	0-10Vdc	0-10Vdc, 2-10Vdc, 4-20mA, 0-20mA	Select the signal type for the room humidity analog input. (Only appears if ControlProfile is set to InternAnalog or RoomRHSrc is set to RoomRH.)	

Sub-Menu	Setting	Default	Range	Description/Notes
Physical IO	SupplyRHSigType:	0-10Vdc	0-10Vdc, 2-10Vdc, 4-20mA, 0-20mA	Select the signal type for the duct or supply high limit humidity analog input. (Only appears if ModHLProfile is set to InternAnalog or SupplyHLReadingSrc is set to SupplyHLRH.)
Extended Config	AlarmBuzzer:	Disabled	Normal, Disabled	Select whether to enable or disable the alarm buzzer sound whenever there is a system warning. This will not affect the Status Display LED.
	SysLogLevel:	Debug	None, Emergency, Alert, Critical, Error, Warning, Notice, Info, Debug	Select the type of information to be stored on log file. (The humidifier must be connected to an SD card.)
	FanOffDelay:	5min	min: 5min, max: 20min	Set the delay time after which the SDU fan will close once it is no longer needed. (Only applicable for humidifiers having the SDU option.)
	FanTrgt:	None	None, SDUFan	Select whether to enable or disable the SDU option. If set to <i>None</i> , the SDU will not operate. (Only applicable for humidifiers having the SDU option.)
	MinSteamOut:	5%	min: 1%, max: 25%	Set the minimum steam production demand value, below which no steam will be produced.
	DrainInterval:	6hr	min: 0hr, max: 24hr	Set the frequency of the drain cycle. In general, a more frequent drain cycle is required as the water hardness level rises. The drain cycle setting does not affect the AFEC system.
	DrainVolume:	100%	min: 25%, max: 100%	Define the volume of water that is drained from the chamber, relative to the total capacity of the chamber.
	MaxOutput:	100%	min: 0%, max: 100%	Set the maximum steam output of the humidifier relative to its total capacity. (Only applicable for modulating humidifiers.)
	IdleTime:	72hr	min: 24hr, max: 72hr	Set the amount of time the humidifier can remain in standby mode until an automatic drain cycle is performed.
	IdleTempStpnt:	32°F [0°C]	min: 32°F, max: 104°F [min: 0°C, max: 40°C] Units: C, F	Set the idle temperature setpoint value for the evaporation chamber when there is no demand.
	AntiFreezeStpnt:	50°F [10°C]	min: 41°F, max: 59°F [min: 5°C, max: 15°C] Units: C, F	Set the evaporation chamber antifreeze temperature. (Only appears for units with the weather proof enclosure, if the antifreeze option is enabled.)
	BlowdownRate:	0%	min: 0%, max: 100%	Define the rate of boiler blowdown or water dilution, in order to minimize water impurities.
	ServInterval:	1000hr	min: 1000hr, max: 3000hr	Set the time of operation before the humidifier calls for servicing.
	TankRinseInterval:	3day	min: 1day, max: 7day	Set the amount of time the humidifier stays in "Idle" or "Off" mode, before the evaporation chamber undergoes an automatic rinse cycle.
	ServOperation:	Allowed	Not Allowed, Allowed	Select whether to enable the unit to continue producing steam, even when it is due for servicing. When set to <i>Allowed</i> , the unit will continue operating even when a service alarm is active.
	FillMode:	Pulsed	OneShot, Pulsed	Select the water filling method for the fill valve: When set to <i>OneShot</i> , water will continuously flow. When set to <i>Pulsed</i> , water will flow in short bursts.
TankRinseIdle:	On	Off, On	Select whether to enable automatic rinse cycles while the humidifier is in "Idle" mode. When set to <i>Off</i> , the <i>TankRinseInterval</i> setting is disabled if the humidifier is turned on.	
TankRinseOff:	Off	Off, On	Select whether to enable automatic rinse cycles while the humidifier is turned off. When set to <i>Off</i> , the <i>TankRinseInterval</i> setting is disabled if the humidifier is turned off.	

Menu - Integration [Level 5 - Requires level 5 password in order to access]

Sub-Menu	Setting	Default	Range <i>(* indicates no configuration; display only)</i>	Description/Notes
Network	Device [4]			
	DeviceName:	-		Establish a name for the device.
	Location:	-		Establish a designated location for the unit.
	Description:	-		Establish a brief description for the unit.
	DeviceInstance:	0153001 (0x000255a9)		Define the device instance value.
	HTTPServer [2]			
	HttpServerUnits:	Imperial	Metric, Imperial	Select whether to use a metric or imperial system of units for the web server.
	WebPriorityForWriting:	15	min: 1, max: 16	Set the priority level assigned for writing.
	BACnetServer [3]			
	Language:	English	<i>(Language options vary based on region.)</i>	Select the language for the BACnet server.
	ListMode:	Integrator	Integrator, Advanced, Factory	Select the category of BACnet objects to display.
	Units:	Imperial	Metric, Imperial	Select whether to use a metric or imperial system of units for the BACnet server.
	BACnetMSTP [5]			
	MaxMaster:	127	min: 1, max: 127	Configure MaxMaster value to increase network efficiency when there are less than 127 devices on the network. For optimal efficiency, set value to the highest MAC address in the MS/TP network.
	MaxInfoFrames:	1	min: 1, max: 3	Configure the maximum number of information messages the controller may transmit, before it must pass the token to the next controller.
	AutoBaud:	Yes	No, Yes	Enable or disable automatic baud rate detection.
	BaudRate:	38400	9600, 19200, 38400, 76800	Select the baud rate for data transfer.
	MAC:	001		Set the MS/TP network MAC address.
	BACnetIP [1]			
	BIPPort:	47808	min: 0, max: 65535	Set the User Datagram Protocol (UDP) port number. BACnet port number is set by default.
	ModbusServer [1]			
	Units:	Imperial	Metric, Imperial	Select whether to use a metric or imperial system of units for the Modbus server.
	ModbusRTU1In [4]			
	MAC:	1	min: 0, max: 247	Set the Modbus MAC address.
Autobaud:	No	No, Yes	Enable or disable automatic baud rate detection.	
PortConfig:	No Parity, 2 Stop Bits	No Parity, 2 Stop Bits Even Parity, 1 Stop bit Odd Parity, 1 Stop bit	Select the Modbus communication port configuration.	
BaudRate:	19200	9600, 14400, 19200, 38400, 57600	Select the baud rate for data transfer.	
Extended Config	SysLogIF:	IP0:192.168.92.101: 2971		Select the IP address for the system log interface.

Sub-Menu	Setting	Default	Range (* indicates no configuration; display only)	Description/Notes
Communication	IPSettings [10]			
	DHCP:	Inactive	Inactive, Active	Select whether to enable Dynamic Host Configuration Protocol (DHCP) to automatically provide an IP address.
	RstIPSetting:	No	No, Yes	Select whether to restart the IP module, in order to allow recent parameter modifications to be effective.
	StaticAddress:	192.168.92.200		Configure the static IP address.
	StaticSubnetMask:	255.255.255.0		Configure the static subnet mask.
	StaticDefaultGateway:	192.168.0.100		Configure the static default gateway.
	StaticDnsServer:	192.168.10.50		Configure the static DNS server.
	ActualAddress:	<i>Current value</i>	*	Displays the actual IP address.
	ActualSubnetMask:	<i>Current value</i>	*	Displays the actual subnet mask.
	ActualDefaultGateway:	<i>Current value</i>	*	Displays the actual default gateway.
	ActualDnsServer:	<i>Current value</i>	*	Displays the actual DNS server.
ETHSettings [1]				
EthernetMacAdd:	<i>Current value</i>	*	Displays the MAC address of the Ethernet interface. (Only applicable if using an Ethernet connection.)	

List of Alarms

Table 13 - List of Alarms

Display	Description	Alarm Reset
AirFlow	Indicates that the airflow sensor is open. Verify that the signal from the airflow sensor is present at the controller's input on the PCB and verify wiring.	Automatic
SupplyHighLimit	Indicates that the high limit item is open. Verify that the signal from the supply high limit sensor is present at the controller's input on the PCB and verify wiring.	Automatic
Interlock	Indicates that the interlock and the cut-out circuitry are open. Verify that the signal from the interlock sensor is present at the controller's input on the PCB and verify wiring.	Automatic
HighLimitCutout	Indicates that the high limit cutout has been activated due to a humidity reading that exceeds the high limit setpoint. Ensure that the high limit humidistat is operating correctly and that the distance between the sensor and the steam dispersion manifold is sufficient (15 ft [4.6 m]).	Automatic
ThermalCutout	Indicates that the thermal cutout sensor is open. Verify that the signal from the thermal cutout sensor is present at the controller's input on the PCB and verify wiring. If that the high temperature switch has been activated due to an abnormal temperature reading, ensure that the humidifier is not operating below standard water level and verify the operation of the water level sensor.	Automatic
WaterLevel	Indicates that the capacitive water level sensor is defective or incorrectly wired. Check sensor and verify wiring.	Automatic
WtrLvlLow	Indicates that the resistive low water level sensor is defective or incorrectly wired. Check sensor and verify wiring.	Automatic
WtrLvlHigh	Indicates that the resistive high water level sensor is defective or incorrectly wired. Check sensor and verify wiring.	Automatic
WaterTemp	Indicates that the evaporation chamber water temperature sensor is defective or incorrectly wired. Check sensor and verify wiring.	Automatic
FoamSensor	Indicates that the foam cutout sensor is defective or incorrectly wired. Check sensor and verify wiring.	Automatic
SSRTemp	Indicates that the solid-state relay temperature sensor is defective or incorrectly wired. Check sensor and verify wiring.	Automatic
ContactorsFuse	Indicates that there is an issue with the printed circuit board fuse. Check the status of the fuse and replace it if defective.	Automatic
FailedPump	Indicates that there was an error during draining due to a pump failure. Verify that the drain pump is operating correctly and that it is not being hindered or obstructed.	Manual *
FillTimeout	Indicates that the water level sensor has not reached the desired value within the programmed delay. Verify and remove any obstructions in the water inlet line and verify that the shut-off valve is not closed.	Manual *
BlockedPiping	Indicates that there was an error during draining due to a blockage in the pipes. Verify and remove any obstructions in the piping and ensure that the drain outlet is not clogged.	Manual *
HeatTimeout	Indicates that the water temperature in the evaporation chamber has not reached the boiling point within the programmed delay. Verify the temperature of the supply water.	Manual *
Overheat	Indicates that the evaporation chamber temperature sensor has detected a temperature reading greater than or equal to 221°F (105°C). Verify the operation of the water level sensor and ensure that the water supply piping is not obstructed.	Manual *
WaterLeak	Indicates that a water leak has been detected. Verify the water line for signs of leaks and ensure that all piping and water connections have been properly installed and secured.	Manual *
Foaming	Indicates that there have been three foaming events detected in the last hour. Verify the quality of the supply water. If chemical products were used to clean the evaporation chamber during maintenance, rinse the chamber properly with water before re-installing the chamber.	Manual *
FanFault	Indicates that there is a problem with the SDU fan. Verify the signal and the operation of the SDU fan. (Only applicable for humidifiers having the SDU option.)	Manual *
ServiceDue	Indicates that the due date for servicing the evaporation chamber has arrived. See Service section on page 52 for details.	Manual **

* Use *Reset Alarms* function in *Request* setting (see page 44).

** Use *Reset Counters* function in *Request* setting (see page 44).



Start-up Procedure



Initial verification and start-up must be carried out by suitably qualified personnel.

It is strictly recommended to follow this start-up procedure in order to avoid any anomaly resulting from inaccurate installation of the components. In case of any problems or discrepancies, consult the Troubleshooting section (see page 56).

Initial Verification

Clearance	1. Ensure that the humidifier cabinet is installed in a location in which the humidifier can be serviced correctly.	<input type="checkbox"/>
	2. Verify that the power supply (voltage) conforms to the appliance name plate on the side of the humidifier.	<input type="checkbox"/>
Electrical	3. Confirm that 24Vac is present between tab 1&2 of JP20 and JP25 on the printed circuit board.	<input type="checkbox"/>
	4. Ensure that water is supplied to the humidifier and that a shutoff valve is placed outside the humidifier.	<input type="checkbox"/>
Hydraulic	5. With the water shutoff valve turned on, check that the drain connections are connected to the main drain line with sufficient diameter. Ensure that there are no apparent leaks.	<input type="checkbox"/>
	6. Verify that the steam distributors are properly installed into the ventilation duct or that the SDU is properly installed and connected to the humidifier.	<input type="checkbox"/>
Steam	7. Verify that the flexible steam hoses and rigid steam supply pipes are shorter than 16 ft (5 m) in total, are properly sloped and have condensation "S" traps wherever required.	<input type="checkbox"/>
	8. Ensure that the Airflow switch is properly installed and connected to the printed circuit board. If an Airflow switch is not used, verify that a jumper is connected between terminals TB3 1&2.	<input type="checkbox"/>
Controls	9. Ensure that the High limit duct humidistat is properly installed and connected to the printed circuit board. Verify that the setpoint is properly adjusted. If a High limit duct humidistat is not used, verify that a jumper is connected between terminals TB3 1&3.	<input type="checkbox"/>
	10. Ensure that the Interlock is properly connected to the printed circuit board. If the Interlock is not used, verify that a jumper is connected between terminals TB3 1&4.	<input type="checkbox"/>
	11. If a room or duct humidistat is used, verify that it is correctly installed and properly connected to the humidifier. Verify that the setpoints are properly adjusted.	<input type="checkbox"/>
	12. Turn the power on using the disconnect switch or circuit breaker.	<input type="checkbox"/>
	13. Confirm the control set-up of the humidifier and verify that the setpoints are properly adjusted.	<input type="checkbox"/>



Start-Up



Start-up

1. Proceed to start-up the humidifier, as follows:
 - a) Turn on the humidifier by pressing and holding the Power button  for 3 seconds. Verify that the controller Status Display LED is blue.
 - b) Verify that there is a humidity demand displayed on the LCD screen of the humidifier.
 - c) Ensure that the water supply valve connected to the humidifier is turned on and that water is flowing directly to the humidifier water supply inlet. Ensure that the water shut off valve is turned off.
 - d) Verify the water level as water is filling the evaporation chamber by using the control panel to access the *WaterLevel* setting located in the *Physical IO* sub-menu of the *General* menu. Ensure that there are no water leaks along the water line.
 - e) Once the evaporation chamber has been filled, observe the system for water and steam leaks during several minutes of operation.

Safety Test

2. Check the location of the Airflow switch in the system and its operation by stopping the fan. With no air movement, the humidifier should automatically stop.

Drain and Reset

3. Turn off the humidifier by pressing and holding the Power  button for 3 seconds.
4. Conduct a drain cycle by pressing and holding the Drain button  for 3 seconds. Ensure that the evaporation chamber has been emptied.
5. Once the drain cycle is complete, restart the humidifier by pressing and holding the Power  button for 3 seconds.
6. Reset the Airflow switch if needed.

End

7. The humidifier is now ready for normal operation.
-

Service



WARNING: Danger of hot water. Drain water before servicing.

The humidifier requires regular periodic service to ensure efficient and trouble-free running. Regular service involves cleaning the evaporation chamber and its components manually. Generally, frequency of cleaning can range from 2 months to once a year, depending on the following factors:

- Quality of water
- Frequency of automatic drain cycles
- Demand placed on the humidifier

All SKE4 humidifiers are programmed for 1000 hours of operation. This is a default factory setting.

To view the number of hours the humidifier has run and the number of service hours, use the control panel to access the *Service Menu* (see page 44 for more details).

After 1000 hours of operation have passed, the Status Display LED on the control panel will turn red, indicating that the humidifier is due for servicing. Although the humidifier will continue to operate, it is imperative that service is performed as soon as possible, in order to ensure proper functionality.

Cleaning the Evaporation Chamber

Cleaning the evaporation chamber involves the following steps:

Stage 1 - Drain the evaporation chamber

Stage 2 - Shut down the electrical supply





Stage 3 - Remove and clean the evaporation chamber

Stage 4 - Reinstall the evaporation chamber

Stage 5 - Restart the humidifier

Stage 1 - Drain the evaporation chamber

Before commencing the cleaning procedure, ensure that the evaporation chamber is cool and comfortable enough to handle, as the evaporation chamber and its contents can be extremely hot and can cause burning. To allow the evaporation chamber to cool, initiate a drain cycle:

1. Press and hold the Power  button for 3 seconds to switch off the humidifier.
2. Press and hold the Drain button  for 3 seconds to initiate a drain cycle and empty the evaporation chamber.
3. Once the initial drain cycle is complete, a second drain cycle must be performed to remove any water residue remaining. Press and hold the Power  button for 3 seconds to turn on the humidifier and refill the evaporation chamber with water.
4. Once the chamber has been filled, press and hold the Drain button  once again for 3 seconds to empty the chamber.

At the end of the second drain cycle, check the temperature of the evaporation chamber. To check the temperature, open the front door of the humidifier and touch the chamber with the back of your hand. If necessary, repeat the above steps until the chamber is cool enough to handle.

Stage 2 - Shut down the electrical supply



CAUTION: Risk of electric shock. The electric supply of the humidifier must be shut down. Disconnect the power at the External Breaker/Fused Disconnect before commencing servicing.

Once the evaporation chamber is sufficiently cool, remove the power supply to the humidifier at the disconnect switch or the breaker.

Stage 3 - Remove and clean the evaporation chamber

Disconnect the water inlet.



Uncouple the clamp connectors.



Slightly lift the chamber upwards.



Pull the chamber towards you.

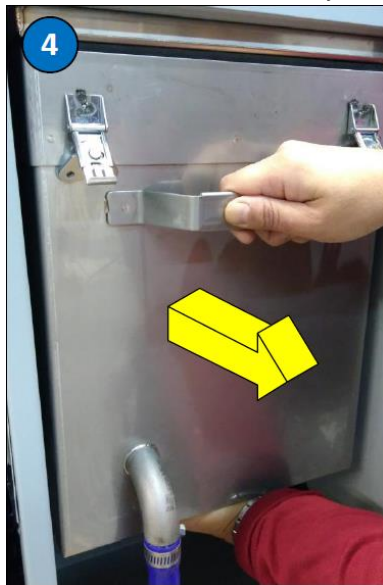

Slide the chamber down.

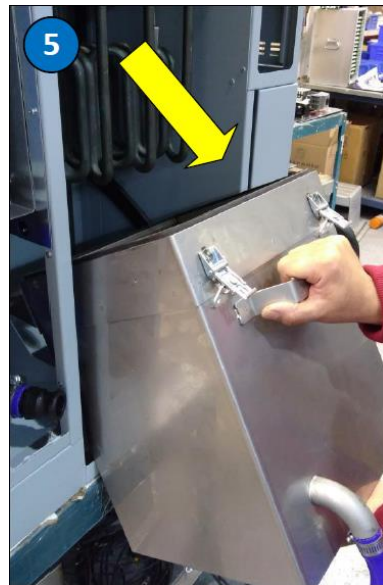

Begin cleaning the chamber.





1. With the front access door removed, disconnect the water inlet attached to the front of the evaporation chamber, by removing the safety pins and manually disconnecting the hose shank coupling from the plumbing section of the humidifier. Connect and secure the water plug to the inlet in order to prevent water from leaking out from the evaporation chamber.
2. Uncouple the clamp connectors.

Model	Method
SKE4-N02 to SKE4-N30	Turn the two latches located around the evaporation chamber.
SKE4-N20L to SKE4-N60	Turn the three latches located around the evaporation chamber.
SKE4-N30X to SKE4-N90	Disengage the latch and remove the band clamp located around the evaporation chamber.

(For models SKE4-N30X to SKE4-N90, skip ahead to step 5.)

3. Once the clamps have been uncoupled, the tank will hang loose on the hooks located behind the chamber. While the chamber is tilted, slightly lift the evaporation chamber upwards, by raising it from the bottom with one hand, and holding onto the handle with the other.
4. Pull the evaporation chamber towards you using the handle, until it is fully removed from the back hooks.

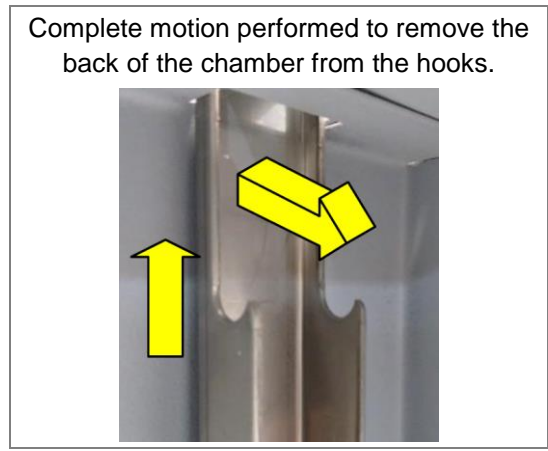

5. Slide the evaporation chamber down using the rail-guided engagement system.
6. Let the evaporation chamber hang at the edge of the rail-guided system (**only for models SKE4-N10 to SKE4-N60**) or remove the chamber in order to begin cleaning.



The evaporation chamber will still contain a few inches of water. Ensure that your footing is secure when removing the chamber. Take extra precautions when removing the evaporation chamber from large humidifiers, which may feel heavy when being pulled down.

7. Clean the evaporation chamber:

- Remove the residue that has accumulated inside the chamber.
- To clean out the remaining scale from the container, use a stiff brush (synthetic filament only) and some vinegar or any weak acid suitable for cleaning stainless steel.



WARNING: The use of a wire brush or any non-recommended acid will void the warranty.

- Do not scrape off the walls of the chamber.
- Ensure that the water inlet aperture is not blocked.



The heating elements are self-cleaning. Any mineral accumulation breaks off and falls to the bottom during operation.







8. Replace the gasket attached to the top of the evaporation chamber.



Stage 4 - Reinstall the evaporation chamber

1. Slide the evaporation chamber back up the rail-guided engagement system until it is secured back on top.
2. Recouple the clamp connectors.
3. Disconnect the water plug and reconnect the water inlet to the evaporation chamber.
4. Turn the power back on at the disconnect switch or the breaker.

Stage 5 - Restart the humidifier

1. Press and hold the Power  button for 3 seconds to power on the humidifier.
2. Conduct a performance test by verifying the water level of the evaporation chamber as it is filled with water. Verify that there are no leaks.
3. Conduct a drain test by turning off the humidifier using the Power  button and performing a drain cycle using the Drain button .
4. Restart the humidifier to resume normal operation by pressing and holding the Power  button for 3 seconds.
5. To reset the service counters and clear the alarm warning after servicing:
 - a. Using the control panel, access the *Request* setting located in the *Command* sub-menu of the *Service* menu.
 - b. Select the *Reset Counters* value and press Enter ↵ to reset the service counters.
6. Ensure that the drain cycles are set for every 6 hours of operation. This is the factory default setting and is recommended for city water.
 - To configure the drain cycle frequency, use the control panel to access the *DrainInterval* setting located in the *Quick Config* or *Extended Config* sub-menus of the *Installation* menu.

After the water boils for 6 hours in the chamber, it is laden with minerals and solutions. This affects the humidity output and the efficiency of the humidifier. Diluting the boiling water with a drain cycle will improve the performance of the humidifier.

Troubleshooting

Table 14 - Troubleshooting Guide

Problem	Possible Cause	Corrective Action
<i>Humidifier does not operate (Screen turned Off)</i>	Power is not being supplied to the humidifier.	Check the main power supply and fuses. Verify the disconnect switch and the circuit breaker.
	The low voltage fuse is open.	Check the transformer and the low voltage fuse. Verify that the low voltage circuit is complete.
	Wire harnesses inside the humidifier are not secured properly.	Check the wires harnesses and the main PC board. Verify that all connections have been made properly.
<i>Humidifier does not operate (Screen turned On, Status Display LED: Off)</i>	The humidifier is not powered on.	Verify that the Power button has been pressed and held for 3 seconds for correct activation.
<i>Humidifier does not produce steam (No demand)</i>	<u>For modulating humidifier:</u> No analog signal detected.	Verify the setting of the control input.
	<u>For On/Off humidifier:</u> No demand from humidistat.	Verify the setting of the humidistat.
	Air flow is not detected by air pressure switch.	Check the fan operation.
	High limit humidistat is open.	Check the operation of the high limit humidistat.
	Interlock contact is open.	Check the interlock contact.
	Control wires are not properly secured to the terminal blocks.	Verify the connections of the wires to the control terminal blocks.
<i>No water inside the evaporation chamber or Humidifier does not stop draining</i>	Humidifier is being filled with water but has not yet reached or does not reach the high limit of the water level sensor.	- Verify that the drain valve is open. - Check if the shutoff valve on the water supply line is open. - Verify the operation of the fill valve.
	Humidifier is not being filled with water.	- Check that the fill valve strainer and the external strainer are not blocked.
<i>Humidifier does not drain</i>	Drain valve is clogged.	Check the drain valve.
	During a drain or foaming cycle, the water level sensor has sensed that the water level has not decreased.	Verify that the drain pump, the fill and drain water pipe connections and the water level sensor chamber are not obstructed.
<i>Humidifier is always on Foam cycle (FoamSensor setting displays Foam)</i>	Excessive foaming condition inside the evaporation chamber.	- Verify the quality of the supply water. - Verify if chemical products were used to clean the evaporation chamber during maintenance. Rinse the chamber properly with water. - Check the setting of the drain cycle. Reduce the time between drain cycles.
<i>Humidifier is operating and the Status Display LED is Red (ServiceDue setting displays On)</i>	The humidifier is due for servicing.	Service the evaporation chamber (see Service section on page 52). Use <i>Request</i> setting in <i>Service</i> menu to reset counters (see page 44).
<i>Humidifier is not operating and the Status Display LED is Red (ThermalCutout setting displays Open)</i>	The high temperature switch has sensed abnormal temperature.	Verify if the humidifier was operating below the standard water level. Replace water level sensor if necessary.
<i>Humidifier does not operate (Screen turned Off, Status Display LED: Blue)</i>	The following components can be the cause of this problem: water level sensor, PC board or LCD display.	Call factory for troubleshooting instructions.
<i>Humidifier is producing steam (Screen turned Off, Status Display LED: Blue)</i>	The display FFC cable is not connected properly.	Verify that the connections of the FFC cable are properly secured and are on the correct side.
	The LCD display is defective.	Replace the LCD display.

Exploded View and Bill of Material

Exploded View

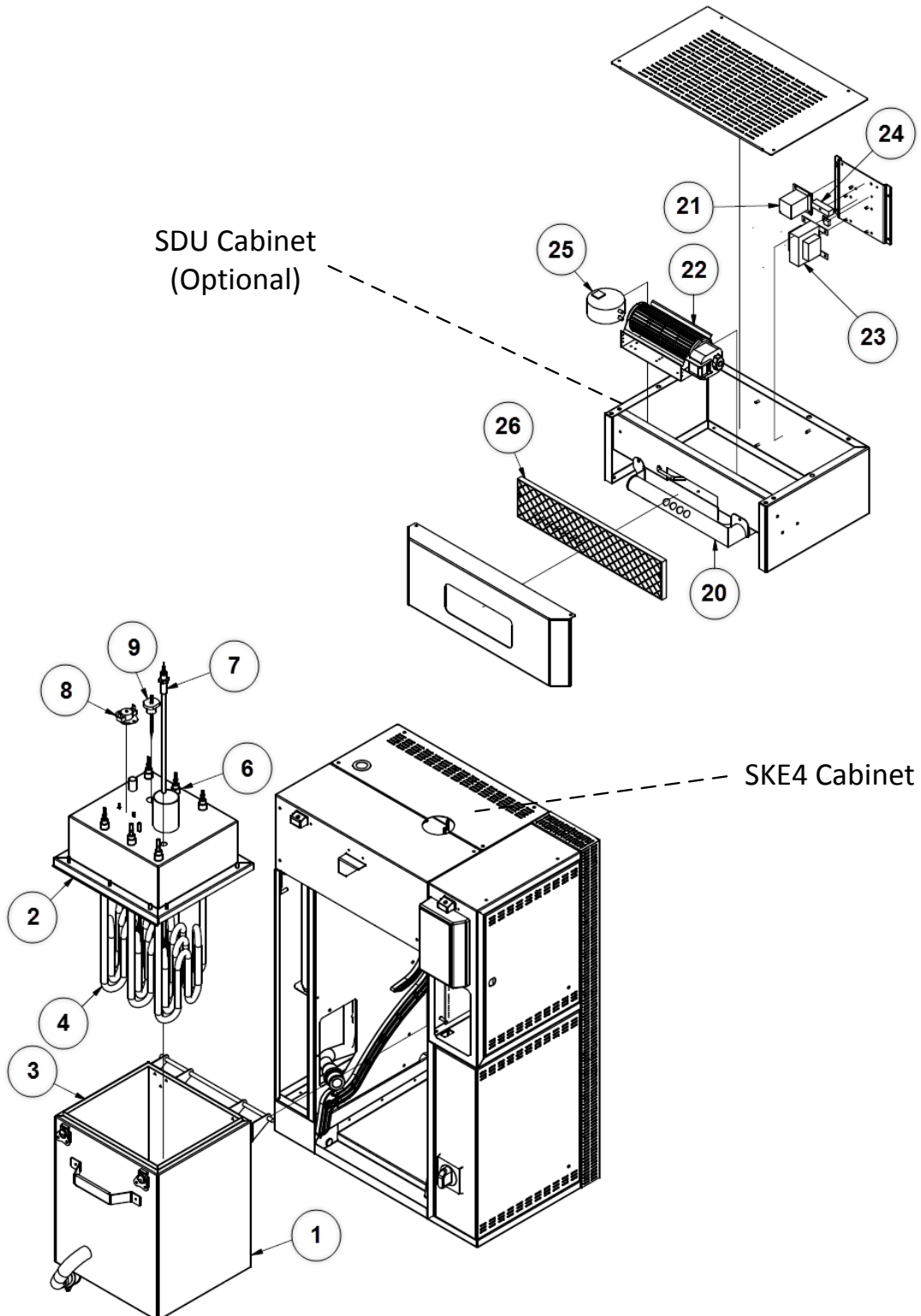

Illustration 47 - Exploded View Part 1 (SKE4-N02 to N60)

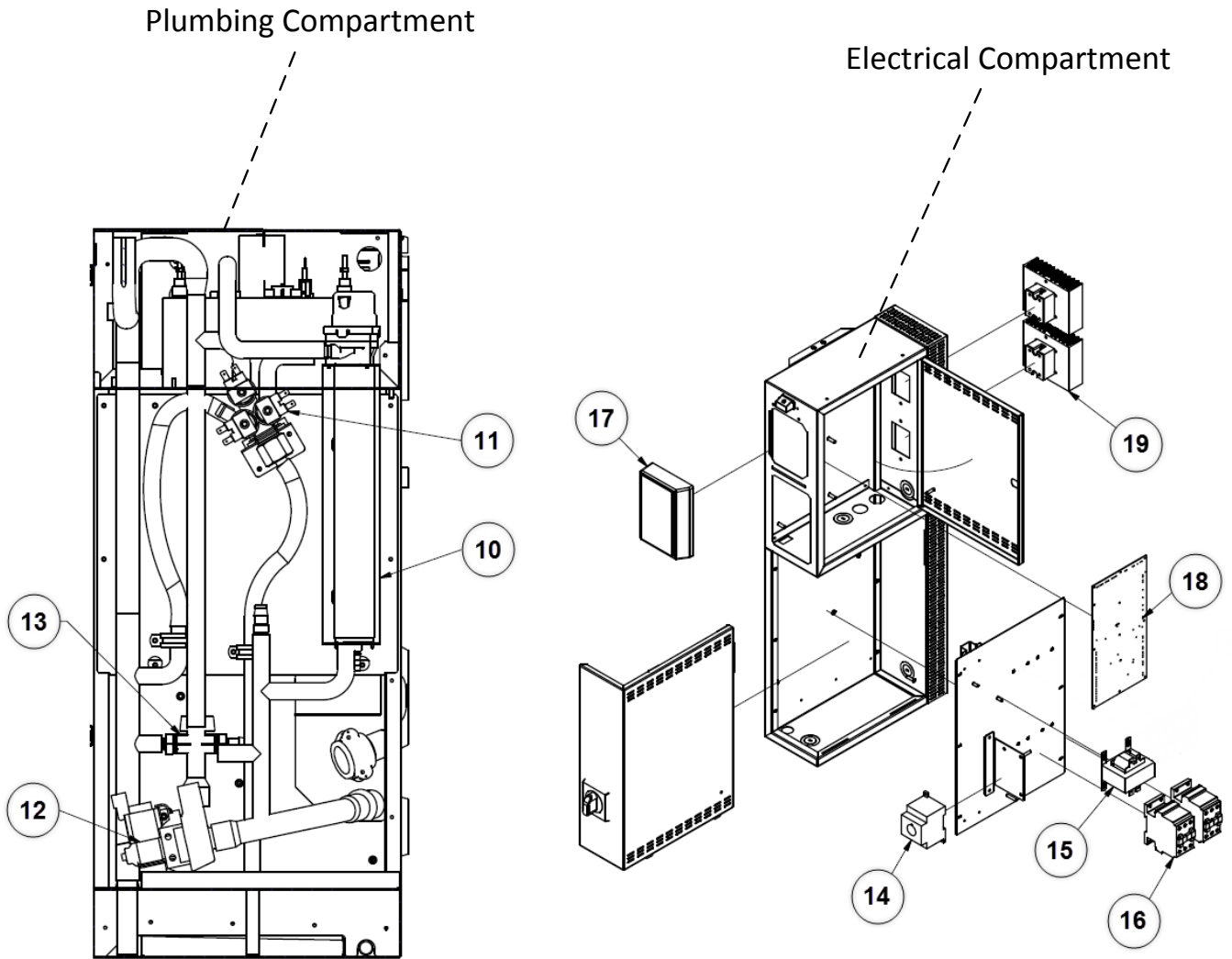

Illustration 48 - Exploded View Part 2 (SKE4-N02 to N60)



Bill of Material

Table 15 - Bill of Material (SKE4-N02 to N60)

<i>Item</i>	<i>Description</i>	<i>Model</i>	<i>Part Number</i>
1	Container of evaporation chamber	SKE4-N02 to SKE4-N06	SP 4222-20
		SKE4-N10 to SKE4-N30	SP 4232-20
		SKE4-N20L to SKE4-N60	SP 4242-20
2	Cover of evaporation chamber	SKE4-N02 to SKE4-N06 (1 phase)	SP 4222-1R
		SKE4-N02 to SKE4-N06 (3 phases)	SP 4222-2R
		SKE4-N10 to SKE4-N14	SP 4232-1R
		SKE4-N16 to SKE4-N30	SP 4232-2R
		SKE4-N20L to SKE4-N60	SP 4242-1R
3	Evaporation chamber gasket	SKE4-N02 to SKE4-N06	SP 4222-8
		SKE4-N10 to SKE4-N30	SP 4232-8
		SKE4-N20L to SKE4-N60	SP 4242-8
4	Heater element	See table below	
5	Washer (heater element)	SKE4-N02 to SKE4-N60	SP 1005
6	S/S hex. jam nut (heater element)	SKE4-N02 to SKE4-N60	SP 2330
7	Temperature sensor	See table below	
8	High temperature switch (klixon)	SKE4-N02 to SKE4-N60	SP 3035
9	Foam sensor	SKE4-N02 to SKE4-N06	SW FOAMSM-ASSY
		SKE4-N10 to SKE4-N30	SW FOAMMED-ASSY
		SKE4-N20L to SKE4-N60	SW FOAMLG-ASSY
10	Water level sensor	See table below	
11	Water supply valve	SKE4-N02 to SKE4-N60	SP 6009
12	Drain pump	SKE4-N02 to SKE4-N60	SP G4101
13	Drain valve	SKE4-N02 to SKE4-N60	SP 4233-10
14	Disconnect switch	See table below	
15	Transformer	See table below	
16	Contactora	See table below	
17	Alphanumeric display	SKE4-N02 to SKE4-N60	SW SKE4DISPLAY-AS
18	Printed circuit board	SKE4-N02 to SKE4-N60	NW SKE4MAIN
19	Solid-state relay	SKE4-N02 to SKE4-N60	SP 3102
20	SDU steam dispersion manifold	SDU4-1	SW 4134
		SDU4-2	SW 4135
		SDU4-3	SW 4136
21	SDU relay	SDU4-1, SDU4-2 & SDU4-3	SP 3114
22	SDU fan	SDU4-1	SP 3011
		SDU4-2	SP 3009
		SDU4-3	SP 3014
23	SDU transformer	See table below	
24	Fuse inside SDU	SDU4-1, SDU4-2 & SDU4-3	SP 5105
25	SDU airflow switch	SDU4-1, SDU4-2 & SDU4-3	SP PSA1-01
26	SDU plastic grill	SDU4-1, SDU4-2 & SDU4-3	SP 4131-11



Table 16 - Additional Bill of Material Details (SKE4-N02 to N60)

<i>Item</i>		4 Heater element	7 Temperature sensor	10 Water level sensor	14 Disconnect switch	15 Transformer	16 Contactor	23 SDU transformer
SKE4-N02	120V/1	SW 5943	NP 7764A	SW SK4WLTR1-HEAD	DP13-3004	SP 3380	SP 3080	-
	240V/1	SW 5932	NP 7764A	SW SK4WLTR1-HEAD	DP13-3004	SP 3310	DP11-6002	SP 3312
	208V/1	SW 5933	NP 7764A	SW SK4WLTR1-HEAD	DP13-3004	SP 3308	DP11-6002	SP 3305
	480V/1	SW 5934	NP 7764A	SW SK4WLTR1-HEAD	DP13-3004	SP 3321	DP11-6002	SP 3329
	600V/1	SW 5935	NP 7764A	SW SK4WLTR1-HEAD	DP13-3004	SP 3341	DP11-6002	SP 3349
SKE4-N04	240V/1	SW 5937	NP 7764A	SW SK4WLTR1-HEAD	DP13-3004	SP 3310	SP 3080	SP 3312
	208V/1	SW 5940	NP 7764A	SW SK4WLTR1-HEAD	DP13-3004	SP 3308	SP 3080	SP 3305
	208V/3	SW 5924	NP 7764A	SW SK4WLTR1-HEAD	DP13-3004	SP 3308	DP11-6002	SP 3305
	480V/1	SW 5941	NP 7764A	SW SK4WLTR1-HEAD	DP13-3004	SP 3321	DP11-6002	SP 3329
	480V/3	SW 5923	NP 7764A	SW SK4WLTR1-HEAD	DP13-3004	SP 3321	DP11-6002	SP 3329
	600V/1	SW 5942	NP 7764A	SW SK4WLTR1-HEAD	DP13-3004	SP 3341	DP11-6002	SP 3349
	600V/3	SW 5925	NP 7764A	SW SK4WLTR1-HEAD	DP13-3004	SP 3341	DP11-6002	SP 3349
SKE4-N06	240V/1	SW 5938	NP 7764A	SW SK4WLTR1-HEAD	DP13-3004	SP 3310	SP 3080	SP 3312
	208V/1	SW 5943	NP 7764A	SW SK4WLTR1-HEAD	DP13-3004	SP 3308	SP 3080	SP 3305
	208V/3	SW 5933	NP 7764A	SW SK4WLTR1-HEAD	DP13-3004	SP 3308	SP 3080	SP 3305
	480V/1	SW 5944	NP 7764A	SW SK4WLTR1-HEAD	DP13-3004	SP 3321	DP11-6002	SP 3329
	480V/3	SW 5934	NP 7764A	SW SK4WLTR1-HEAD	DP13-3004	SP 3321	DP11-6002	SP 3329
	600V/1	SW 5945	NP 7764A	SW SK4WLTR1-HEAD	DP13-3004	SP 3341	DP11-6002	SP 3349
	600V/3	SW 5935	NP 7764A	SW SK4WLTR1-HEAD	DP13-3004	SP 3341	DP11-6002	SP 3349
SKE4-N10	208V/3	SW 5959	NP 7765C	SW SK4WLTR2-HEAD	DP13-3004	SP 3308	SP 3080	SP 3305
	480V/3	SW 5958	NP 7765D	SW SK4WLTR1-HEAD	DP13-3004	SP 3321	SP 3080	SP 3329
	600V/3	SW 5957	NP 7765D	SW SK4WLTR1-HEAD	DP13-3004	SP 3341	SP 3080	SP 3349
SKE4-N14	208V/3	SW 5946	NP 7765C	SW SK4WLTR2-HEAD	DP13-3005	SP 3308	SP 3100	SP 3305
	480V/3	SW 5947	NP 7765D	SW SK4WLTR1-HEAD	DP13-3004	SP 3321	SP 3080	SP 3329
	600V/3	SW 5948	NP 7765D	SW SK4WLTR1-HEAD	DP13-3004	SP 3341	SP 3080	SP 3349
SKE4-N16	208V/3	SW 5960	NP 7765D	SW SK4WLTR1-HEAD	DP13-3005	SP 3308	SP 3100	SP 3351
	600V/3	SW 5958	NP 7765D	SW SK4WLTR1-HEAD	DP13-3004	SP 3341	SP 3080	SP 3353
SKE4-N20	480V/3	SW 5950	NP 7765C	SW SK4WLTR2-HEAD	DP13-3004	SP 3321	SP 3080	SP 3395
	600V/3	SW 5951	NP 7765C	SW SK4WLTR2-HEAD	DP13-3004	SP 3341	SP 3080	SP 3396
SKE4-N30	480V/3	SW 5952	NP 7765C	SW SK4WLTR2-HEAD	DP13-3005	SP 3321	SP 3100	SP 3395
	600V/3	SW 5939	NP 7765C	SW SK4WLTR2-HEAD	DP13-3004	SP 3341	SP 3080	SP 3396
SKE4-N20L	208V/3	SW 5959	NP 7765C	SW SK4WLTR2-HEAD	DP13-3005	SP 3308	SP 3080 (2x)	-
SKE4-N40	480V/3	SW 5950	NP 7765C	SW SK4WLTR2-HEAD	DP13-3005	SP 3321	SP 3080 (2x)	-
	600V/3	SW 5951	NP 7765C	SW SK4WLTR2-HEAD	DP13-3005	SP 3341	SP 3080 (2x)	-
SKE4-N50	480V/3	SW 5950/ SW 5952	NP 7765C	SW SK4WLTR2-HEAD	DP13-3005	SP 3321	SP 3100 (2x)	-
	600V/3	SW 5952	NP 7765C	SW SK4WLTR2-HEAD	DP13-3005	SP 3341	SP 3080 (2x)	-
SKE4-N60	480V/3	SW 5952	NP 7765C	SW SK4WLTR2-HEAD	DP13-3006	SP 3321	SP 3100 (2x)	-
	600V/3	SW 5939	NP 7765C	SW SK4WLTR2-HEAD	DP13-3005	SP 3341	SP 3080 (2x)	-





neptronic®

400 Lebeau blvd, Montreal, Qc, H4N 1R6, Canada

www.neptronic.com

Toll free in North America: 1-800-361-2308

Tel.: (514) 333-1433

Fax: (514) 333-3163

Customer service fax: (514) 333-1091

Monday to Friday: 8:00am to 5:00pm (Eastern time)