

SIEMENS



Siemens BT300 HVAC Drive Operator's Manual

Copyright Notice

Notice

Document information is subject to change without notice by Siemens Industry, Inc. Companies, names, and various data used in examples are fictitious unless otherwise noted. No part of this document may be reproduced or transmitted in any form or by any means, electronic or mechanical, for any purpose, without the express written permission of Siemens Industry, Inc.

Warning

This equipment generates, uses, and can radiate radio frequency energy. If equipment is not installed and used in accordance with the instructions manual, it may cause interference to radio communications. Equipment has been tested and found to comply within the limits for a Class B digital device pursuant to Part 15 of the FCC rules. These limits are designed to provide reasonable protection against such interference when operated in a commercial environment. Operation of this equipment in a residential area is likely to cause interference. Residential area equipment users are required to take whatever measures necessary to correct the interference at their own expense.

Service Statement

Control devices are combined to make a system. Each control device is mechanical in nature and all mechanical components must be regularly serviced to optimize their operation. Siemens Industry, Inc. branch offices and authorized distributors offer Technical Support Programs that will ensure continuous, trouble-free system performance.

For further information, contact your nearest Siemens Industry, Inc. representative.

Copyright 2013 by Siemens Industry, Inc.

FCC Regulations

The manual for an intentional or unintentional radiator shall caution the user that changes or modifications not expressly approved by the party responsible could void the user's authority to operate the equipment.

For a Class B digital device or peripheral, the instructions furnished the user shall include the following or similar statement, placed in a prominent location in the text of the manual:

NOTE: This equipment has been tested and found to comply with the limits for a Class B digital device, pursuant to part 15 of the FCC Rules. These limits are designed to provide reasonable protection against harmful interference in a residential installation. This equipment generates, uses and can radiate radio frequency energy and, if not installed and used in accordance with the instructions, may cause harmful interference to radio communications. However, there is no guarantee that interference will not occur in a particular installation. If this equipment does cause harmful interference to radio or television reception, which can be determined by turning the equipment off and on, the user is encouraged to try to correct the interference by one or more of the following measures:

- *Reorient or relocate the receiving antenna.*
- *Increase the separation between the equipment and receiver.*

-
- *Connect the equipment into an outlet on a circuit different from that to which the receiver is connected.*
 - *Consult the dealer or an experienced radio/TV technician for help.*

To the Reader

Your feedback is important to us. If you have comments about this manual, please submit them to: mailto:Sbt_technical.editor.us.sbt@siemens.com

Credits

APOGEE, APOGEE GO, InfoCenter Administrator, InfoCenter Report Manager, InfoCenter Server, InfoCenter Suite, and Insight are registered trademarks of Siemens Industry, Inc.

Other product or company names mentioned herein may be the trademarks of their respective owners.

Printed in the USA.

Table of contents

Chapter 1 - BT300 Quick Start-up Guide	9
Keypad of the BT300	9
Keypad buttons.....	9
Display	9
Editing values	10
Startup Wizard (P1.19)	11
Siemens Application	12
Specific functions of the Siemens application	12
PID Mini-Wizard (P1.17).....	13
Multi-pump Mini-wizard (P1.18).....	15
Fire Mode Wizard (P1.20)	15
Bypass Wizard (P1.21).....	16
Chapter 2 - User interfaces on Siemens BT300	19
Navigation on keypad	19
Keypad of the drive.....	19
Siemens keypad with graphical display	20
Menu structure	27
Quick setup.....	27
Parameters	27
Siemens NET.....	28
Chapter 3 – Quick Setup (M1)	29
Chapter 4 - Monitor Menu (M2)	31
Group 2: Monitor group	31
Multi-Monitor (M2.1)	31
Basic (M2.2)	32
Timer functions monitoring (M2.3).....	34
PID Controller 1 Monitoring (M2.4).....	34
PID Controller 2 Monitoring (M2.5).....	35
Multi-pump monitoring (M2.6)	35
Fieldbus data monitoring (M2.8).....	35
Temperature inputs monitoring (M2.9)	36
Chapter 5 - Parameters (M3)	39
Parameter programming.....	40
Example Programming with the Graphical Keypad.....	40
Descriptions of signal sources:.....	41
Column explanations	42
Motor settings (M3.1).....	42
Basic Settings	42
Motor Control Settings	43

Start/Stop setup (M3.2).....	45
Control reference settings (M3.3)	46
Ramp & Brakes Setup (M3.4).....	49
I/O Configuration (M3.5)	50
Digital inputs	50
Analog inputs	52
Digital outputs, slot B (Basic).....	54
Expander slots C, D, and E digital outputs	55
Analog outputs, Slot A (Standard)	55
Expander slots C, D, and E Analog Outputs	56
Fieldbus Data Mapping (M3.6)	57
Prohibited Frequencies (M3.7)	58
Limit supervisions (M3.8).....	58
Protections (M3.9)	59
Automatic reset (M3.10)	63
Timer functions (M3.11).....	64
PID-controller 1 (M3.12)	69
Basic settings	69
Setpoints	71
Feedback	72
Feedforward.....	73
Soft fill	74
Process Supervision	74
Pressure Loss Compensation	75
PID-controller 2 (M3.13)	75
Basic settings.....	75
Setpoints	77
Feedback	78
Process supervision	79
Multi-pump (M3.14).....	80
Fire mode (M3.16)	81
Application settings (M3.17)	82
Chapter 6 - Diagnostics (M4)	83
Active faults (M4.1)	83
Reset faults (M4.2)	83
Fault history (M4.3).....	83
Fault history	84
Total counters (M4.4).....	84
Trip counters (M4.5)	85
Software info (M4.6)	85
Chapter 7 - I/O and hardware (M5)	87
Basic I/O (M5.1).....	87
Option board slots.....	88
Real time clock (M5.5)	88
Power unit settings, Cooling Fan control (M5.6).....	89

Sine filter	89
Keypad (M5.7)	89
Fieldbus (M5.8).....	90
Chapter 8 - User Settings, Favorites, and User Level Menus	93
User settings (M6)	93
Parameter backup	93
Favorites (M7).....	94
User levels	94
Chapter 9 - HVAC Application - Additional parameter information	97
Group 3.1: Motor Settings	97
Group 3.2: Start/Stop Setup	98
Group 3.3: Control Reference Settings	104
Group 3.4: Ramp & Brakes Setup	105
Group 3.5: I/O Configuration	106
Group 3.9: Protections.....	109
Group 3.10: Automatic Reset	113
Group 3.12: PID Controller 1	114
Group 3.14: Multi-Pump	118
Chapter 10 - Fault tracing	125
Fault Displays	125
Fault history	126
Fault codes	126

Chapter 1 - BT300 Quick Start-up Guide

Keypad of the BT300

The control keypad is the interface between the BT300 Drivedrive and the user. With the control keypad it is possible to control the speed of a motor, to supervise the state of the equipment and to set the BT300 Drive. The following Figure shows the BT300 Drive

Keypad buttons



Move Backward in Menu
Exit Edit Mode
Reset Faults with long Press

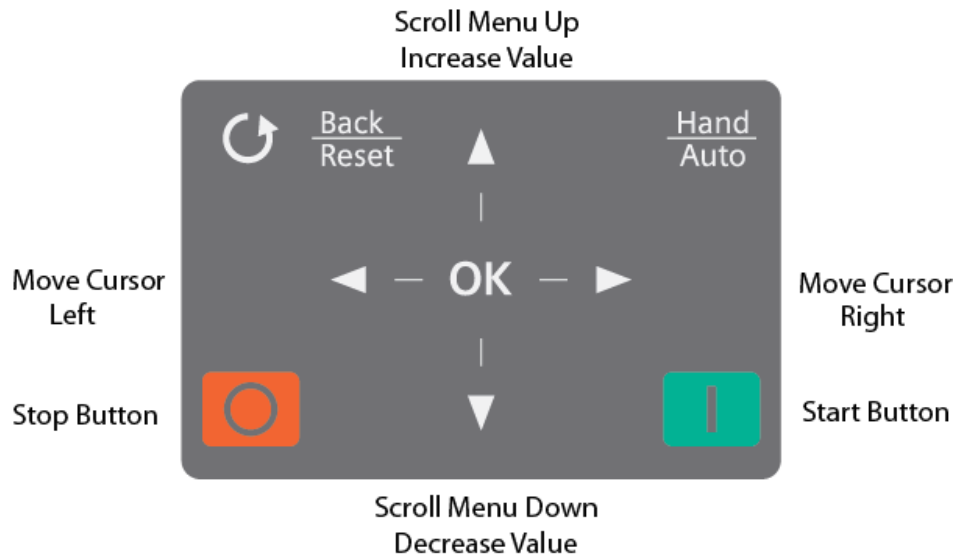

Enter Active Level/Item
Confirm Selection

Figure 1: Siemens BT300 Keypad.

Display

The keypad display indicates the status of the motor and the drive and any irregularities in the motor or drive functions. On the display, the user sees information about the drive and the present location in the menu structure and the item displayed.

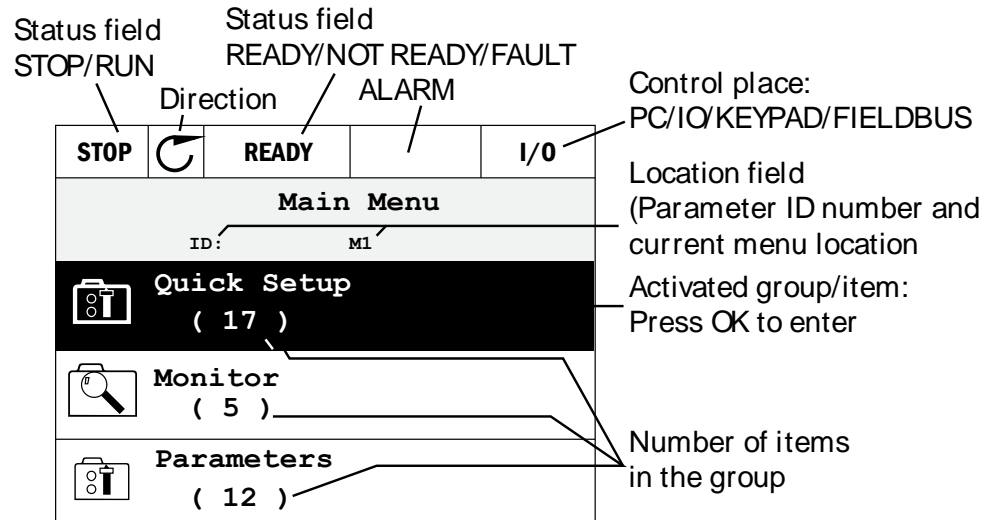

9159.emf

Figure 2:

Editing values

Change value of a parameter following the procedure below:

1. Locate the parameter.
2. Enter the *Edit* mode.
3. Set new value with the arrow buttons up/down. You can also move from digit to digit with the arrow buttons left/right if the value is numerical and change then the value with the arrow buttons up/down.
4. Confirm change with **OK** button or ignore change by returning to previous level with **Back/Reset** button.

Table 1: Editing values on graphical keypad.

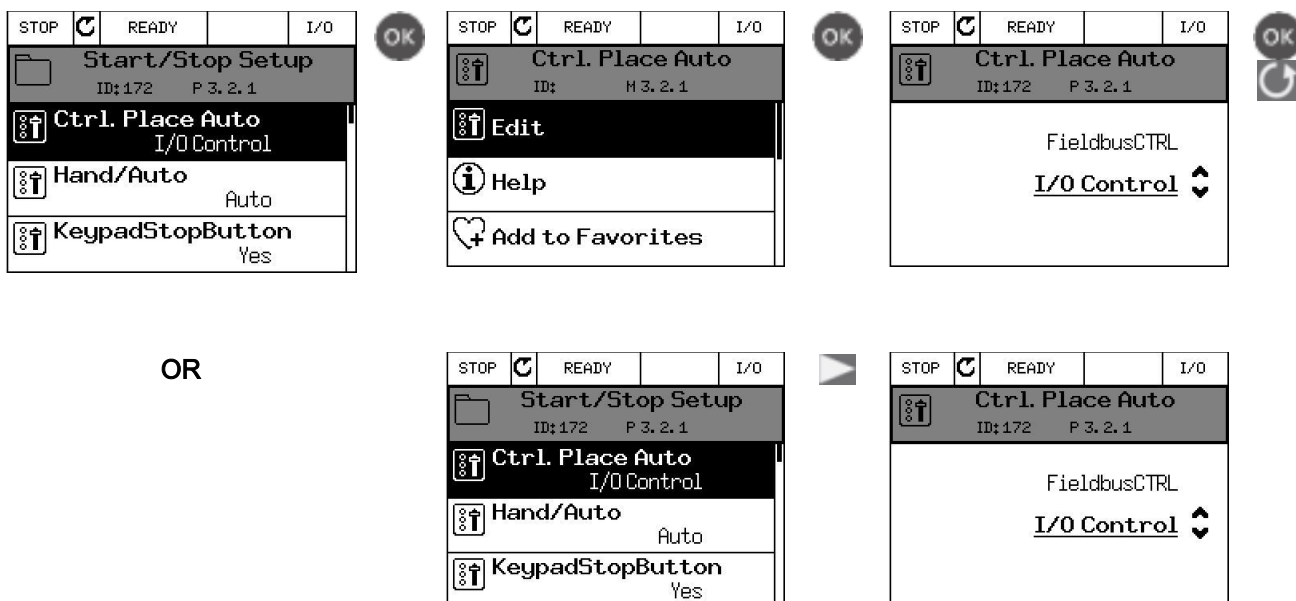

Startup Wizard (P1.19)

In the *Startup Wizard*, you will be prompted for essential information needed by the drive so that it can start controlling your process. In the Wizard, you will need the following keypad buttons:



Left/Right arrows. Use these to easily move between digits and decimals.



Up/Down arrows. Use these to move between options in menu and to change value.



OK button. Confirm selection with this button.



Back/Reset button. Pressing this button, you can return to the previous question in the Wizard. If pressed at the first question, the Startup Wizard will be canceled.

Once you have connected power to your Siemens BT300 variable frequency drive, follow these instructions to easily set up your drive.

1	Language selection (P6.1)	Depends on language package
2	Daylight saving (P5.5.5)	Russia US EU OFF
3	Time (P5.5.2)	hh:mm:ss
4	Year (P5.5.4)	yyyy
5	Day (P5.5.3)	dd.mm.
6	Run Startup Wizard?	Yes No

If the option **Yes** is selected, you will be prompted for the following values:

7	Choose Application	Pump Fan
8	Motor Nominal Voltage	Range: Varies
9	Motor Nominal Frequency	Range: 8...320 Hz
10	Motor Nominal Speed	Range: 24...19200 rpm
11	Motor Nominal Current	Range: Varies
12	Motor Cos Phi	0.3...1.0
13	Motor Nominal Power	Range: Varies

14	Minimum Frequency	Range: 0.00...60.00 Hz
15	Maximum Frequency	Range: 0.00...320.00 Hz
16	I/O A Ctrl Ref	MotorPot Ref PID1 Ref AI1 + AI2 AI2 AI1 Fieldbus Keypad Ref PresetFreq0
17	Accel Time 1	0.1...3000.0 s
18	Decel Time 1	0.1...3000.0 s
19	Ctrl. Place Auto	Fieldbus CTRL I/O Control
20	Automatic Restart	Enabled Disabled
21	Start Function	Flying Start Ramping
22	Bypass Wizard	Yes No

The Startup Wizard is now complete.

The Startup Wizard can be re-initiated by activating the parameter *Restore factory defaults* (par. P6.5.1) in the *Parameter backup* sub-menu (M6.5) **OR** with parameter P1.19 in the Quick setup menu [→ 29].

Siemens Application

The Siemens drive contains a preloaded application for instant use. Should this application not meet the requirements of your process please contact the manufacturer for information on special applications.

The parameters of this application are listed in Chapter 5 - Parameters (M3) [→ 39] and explained in more detail in Chapter 9 - HVAC Application - Additional parameter information [→ 97].

Specific functions of the Siemens application

The Siemens BT300 application is an easy-to-use application for not only basic pump and fan applications where only one motor and one drive is needed, but also offers extensive possibilities for PID control.

Features

- **Start-Up wizard** for extremely fast setup for basic pump or fan applications.
- **Mini-Wizards** to ease the setup of applications.

- **Hand/Auto button** for easy change between (keypad) and auto control place. The auto control place is selectable by parameter (I/O or Fieldbus).
- **Control page** for easy operation and monitoring of the most essential values.
- **Run interlock** input (Damper interlock). Drive will not start before this input is activated.
- **Fire mode**
- Different **preheat modes** used to avoid condensation problems.
- **Maximum output frequency 320 Hz.**
- Selection for the **U.S. and metric units**. E.g. "kW or "hp", °C or °F (factory preset according to customer's wish)
- **Real-time clock and timer functions** available. Possible to program 3 time channels to achieve different functions on the drive (e.g. Start/Stop and Preset frequencies).
- **Overtemperature tripping prevention** by dropping the switching frequency and the output frequency (Automatic Derating)
- **External PID-controller** available. Can be used to control e.g. a valve using the drive's I/O.
- **Sleep mode function** which automatically enables and disables drive running with user defined levels to save energy.
- **2-zone PID-controller** (2 different feedback signals; minimum and maximum control).
- **Two setpoint sources** for the PID-control. Selectable with digital input.
- **PID setpoint boost function.**
- **Soft fill function.** E.g.: Preset speed is used at start until the pipe is full and the pressure defined by parameter is reached
- **Feedforward function** to improve the response to the process changes.
- **Process value supervision.**
- **Multi-Pump control.**
- **Pressure loss compensation** for compensating pressure losses in the pipe work. For example, when a sensor is incorrectly placed near the pump or fan.

PID Mini-Wizard (P1.17)

The *PID mini wizard* is activated in the *Quick Setup* menu. This wizard presupposes that you are going to use the PID controller in the "one feedback / one setpoint" mode. The control place will be I/O A and the default process unit '%'.
The *PID mini wizard* asks for the following values to be set:

1	Process unit selection	(Several selections. See P3.12.1.4 [→ 69])
---	------------------------	--

If a process unit other than % is selected, the following questions display. Otherwise, the Wizard jumps directly to Step 5.

2	Process unit min	
3	Process unit max	

4	Process unit decimals	0...4
---	-----------------------	-------

5	Feedback 1 source selection	See the Setpoints [→ 77] section for selections.
---	-----------------------------	--

If one of the analog input signals is selected, Step 6 displays. Otherwise, the Wizard jumps directly to Step 7.

6	Analog input signal range	0 = 0...10 V / 0...20 mA 1 = 2...10 V / 4...20 mA See the Analog inputs [→ 52] section for more information.
---	---------------------------	--

7	Error inversion	0 = Normal 1 = Inverted
---	-----------------	----------------------------

8	Setpoint source selection	See the Setpoints [→ 71] section for selections.
---	---------------------------	--

If one of the analog input signals is selected, Step 9 displays. Otherwise, the Wizard jumps directly to Step 11.

If either of the options Keypad Setpoint 1 or 2 is selected, then Step 10 displays.

9	Analog input signal range	0 = 0...10 V / 0...20 mA 1 = 2...10 V / 4...20 mA See the Analog inputs [→ 52] section for more information.
---	---------------------------	--

10	Keypad setpoint	
----	-----------------	--

11	Sleep function?	No Yes
----	-----------------	-----------

If the option 'Yes' is selected, you will be prompted for the following values:

12	Sleep frequency limit 1	0.00...320.00 Hz
----	-------------------------	------------------

13	Sleep delay 1	0...3000 s
----	---------------	------------

14	Wake-up level 1	Range depends on selected process unit.
----	-----------------	---

Multi-pump Mini-wizard (P1.18)

The Multi-Pump mini-wizard asks the most important questions for setting up a Multi-Pump system. The PID mini-wizard always precedes the Multi-Pump mini-wizard. The keypad guides you through the steps in the PID Mini-Wizard (P1.17) [→ 13] and then continues with the following set of questions:

15	Number of motors	1...4
16	Interlock function	0 = Not used 1 = Enabled
17	Autochange	0 = Disabled 1 = Enabled

If the Auto-change function is enabled, the following questions will display. Otherwise, the Wizard jumps directly to Step 21.

18	Include FC	0 = Disabled 1 = Enabled
19	Autochange interval	0.0...3000.0 h
20	Autochange: Frequency limit	0.00...60.00 Hz

21	Bandwidth	0...100%
22	Bandwidth delay	0...3600 s

After this, the keypad will show the digital input and relay output configuration done by the application. Write these values down for future reference.

Fire Mode Wizard (P1.20)



NOTE:
THE WARRANTY IS VOID, IF THE FIRE MODE FUNCTION IS ACTIVATED.

Test Mode can be used to test the Fire Mode function without voiding the warranty. Read important information about the password and warranty issues in chapter 8.13, before you proceed.

Fire Mode Wizard is intended for easy commissioning of the Fire Mode function. The Fire Mode Wizard can be initiated by choosing *Activate* for parameter 1.1.2 in the Quick setup menu.

1	Fire Mode frequency source (P3.17.2)	Several selections, see the Table <i>Fire Mode Parameters</i> in the Fire mode (M3.16) [→ 81] section.
---	--------------------------------------	--

If any other source than 'Fire mode frequency' is selected the wizard will jump directly to question 3.

2	Fire Mode frequency (P3.17.3)	8.00 Hz...MaxFreqRef (P3.3.1.2)
3	Signal activation?	Should the signal activate on opening or closing contact? 0 = Open contact 1 = Closed contact
4	Fire Mode activation on OPEN (P3.17.4)/ Fire Mode activation on CLOSE (P3.17.5)	Choose the digital input to activate Fire mode. See also chapter 8.13.
5	Fire Mode reverse (P3.17.6)	Choose the digital input to activate the reverse direction in Fire mode. DigIn Slot0.1 = Always direction FORWARD DigIn Slot0.2 = Always direction REVERSE
6	Fire Mode password (P3.17.1)	Choose password to enable the Fire Mode function. 1234 = Enable Test mode 1002 = Enable Fire Mode

Bypass Wizard (P1.21)

The Bypass wizard helps you to easily commission the Bypass function. The Bypass I/O are automatically configured based on the mode selected.

1	Select the Bypass mode.	Electronic Conventional Disabled
---	-------------------------	---

If **Electronic** is selected, the following steps display. Otherwise, the display returns to the Main Menu.

2	Set the delay when switching between Drive and Bypass modes.	Min: 1.0 s Max: 30.0 s Default: 1.0 s
3	Enable essential services?	Enabled Disabled

If **Enabled** is selected, Step 4 displays. Otherwise, the Wizard jumps directly to Step 5.

4	Select a digital input to control essential services.	Min: Max: Default: DigIN SlotA.6
---	---	---

5	Enable the Remote Bypass?	Enabled Disabled
---	---------------------------	----------------------------

If **Enabled** is selected, Step 6 displays. Otherwise, the Wizard jumps directly to Step 7.

6	Select the Start command source in Remote Bypass and Auto mode.	FieldbusCTRL I/O Control
---	---	------------------------------------

7	Enable Interlock logic?	Enabled Disabled
---	-------------------------	----------------------------

If **Enabled** is selected, Step 8 displays. Otherwise, the Wizard jumps directly to Step 9.

8	Select an Interlock logic delay.	Min: 0.0 s Max: 120.0 s Default: 0.0 s
---	----------------------------------	---

9	Enable Auto Bypass?	Enabled Disabled
---	---------------------	----------------------------

If **Enabled** is selected, Step 10 displays. Otherwise, the Wizard jumps directly to Step 11.

10	Set the delay between the fault occurrence and Auto Bypass activation.	Min: 0.0 s Max: 30.0 s Default: 1.0 s
----	--	--

11	Using the right arrow button  , select the faults that will the drive to automatically switch to Bypass mode.	Any Fault Undervoltage Overvoltage Overcurrent AI Low Unit Temperature Motor Overtemp External Fault Underload Fault
----	---	--

The Bypass Wizard is now complete. Press **OK** to return to the Main Menu.

For more information on the Bypass, see the *Bypass Installation Instructions* (DPD01375) and the *Bypass Operator's Manual* (DPD01391).

Chapter 2 - User interfaces on Siemens BT300

This chapter presents the different user interfaces on Siemens BT300 :

- Keypad
- Siemens NET
- Fieldbus

Navigation on keypad

See the keypad button and display description in the Siemens keypad with graphical display [→ 20] section.

The data on the control keypad are arranged in menus and submenus. Use the Up and Down arrows to move between the menus. Enter the group/item by pressing the OK button and return to the former level by pressing the Back/Reset button.

The **Location** field indicates your current location. The **Status** field gives information about the present status of the drive. See the Figure Main Menu [→ 20].

The basic menu structure is depicted in the Menu structure [→ 27] section.

Keypad of the drive

The control keypad with graphical interface is the interface between the Siemens BT300 variable frequency drive and the user. With the control keypad it is possible to control the speed of a motor, to supervise the state of the equipment and to set the variable frequency driver's parameters.

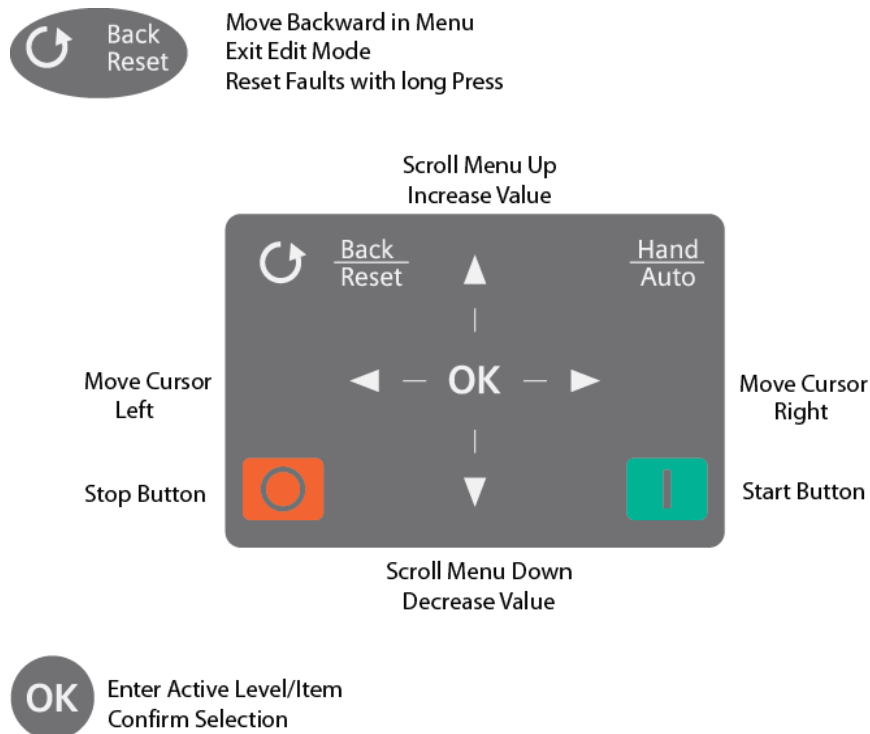

Figure 3: Keypad buttons.

Siemens keypad with graphical display

The graphical keypad features an LCD display and 9 buttons.

Keypad display

The keypad display indicates the status of the motor and the drive and any irregularities in motor or drive functions. On the display, the user sees information about his present location in the menu structure and the item displayed.

See Menu structure [→ 27] for a comprehensive view of the menu structure.

Main menu

The data on the control keypad are arranged in menus and sub-menus. Use the Up and Down arrows to move between the menus. Enter the group/item by pressing the **OK** button and return to the previous level by pressing the **Back/Reset** button.

The *Location field* indicates your current location. The *Status field* gives information about the present status of the drive. See the following Figure.

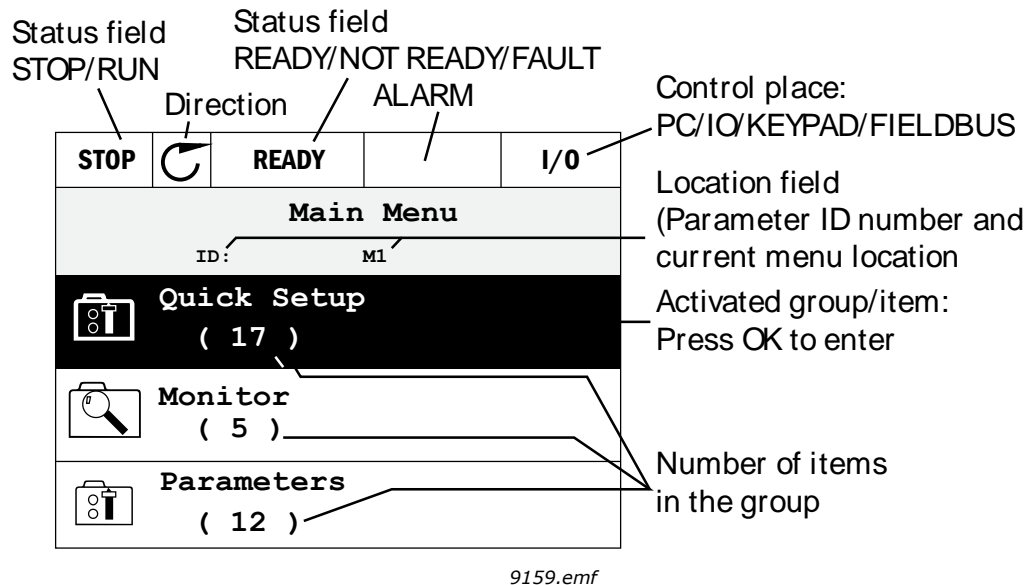

Figure 4: Main menu.

Using the graphical keypad

Editing values

Change value of a parameter following the procedure below:

1. Locate the parameter.
2. Enter the *Edit* mode.
3. Set new value with the arrow buttons up/down. You can also move from digit to digit with the arrow buttons left/right if the value is numerical and change then the value with the arrow buttons up/down.

- Confirm change with **OK** button or ignore change by returning to previous level with **Back/Reset** button.

Table 2: Editing values on graphical keypad.

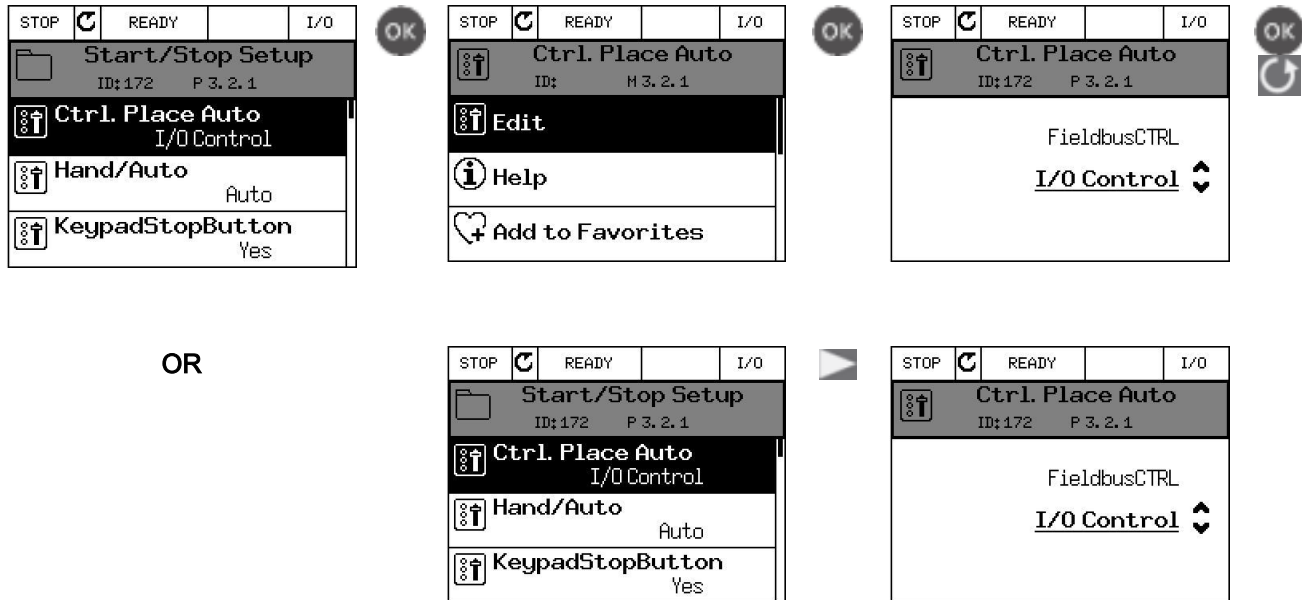

OR

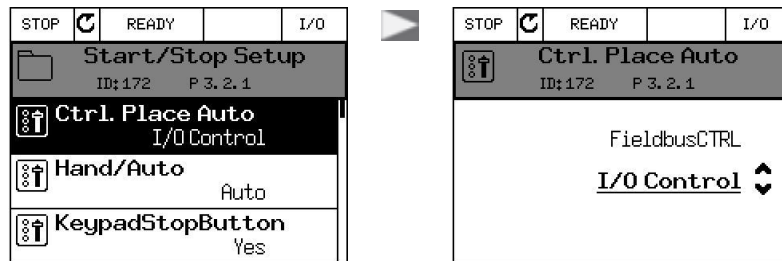

Resetting a Fault

Instructions for how to reset a fault can be found in the Fault Displays [→ 125] section of *Chapter 10*.

Hand/Auto control button

The Hand/Auto button  is used for two functions: to quickly access the Control page and to easily change between the Hand (Keypad/Loc) and Auto control places.

Control places

The *control place* is the source of control where the drive can be started and stopped. Every control place has its own parameter for selecting the frequency reference source. In the HVAC drive, the *Hand control place* is always the keypad. The *Auto control place* is determined by parameter **P1.15** (I/O or Fieldbus). The selected control place is displayed on the right side of the keypad status bar.

Auto control place

I/O A, **I/O B** and **Fieldbus** can be used as Auto control places.

- I/O A and Fieldbus have the lowest priority and can be chosen with parameter P3.2.1 (*Ctrl. Place Auto*).
- I/O B can bypass the Auto control place selected with parameter P3.2.1 using a digital input. The digital input is selected with parameter P3.5.1.5 (*I/O B Ctrl Force*).

Hand control

The keypad is always used as control place while in Hand control.

- Hand control has a higher priority than Auto control. Therefore, if, for example, bypassed by parameter P3.5.1.5 through digital input while in *Auto*, the control place will still switch to Keypad if **Hand** is selected. Switching between Hand and Auto control can be done by pressing the **HAND/AUTO** button on the keypad or by using the *Hand/Auto* (ID211) parameter.

Changing the Control Place from Auto to Hand.



1. From any screen in the menu structure, press the **HAND/AUTO** button .
 - ⇒ The **HandAuto Button** menu displays with **Drive** selected.
2. Press **OK** to display the Drive menu.
3. Use the **Arrow up** or the **Arrow down** button to select **Hand** and press **OK** to confirm.
 - ⇒ The Hand menu displays with **Activate** selected.
4. Press **OK** to enter Hand mode and display the Keypad Reference menu.
5. Use the **Arrow up** or the **Arrow down** button to set the reference values and press **OK** to confirm.
 - ⇒ The control place is now in Hand mode.

Table 3: Changing the Control Place from Auto to Hand.

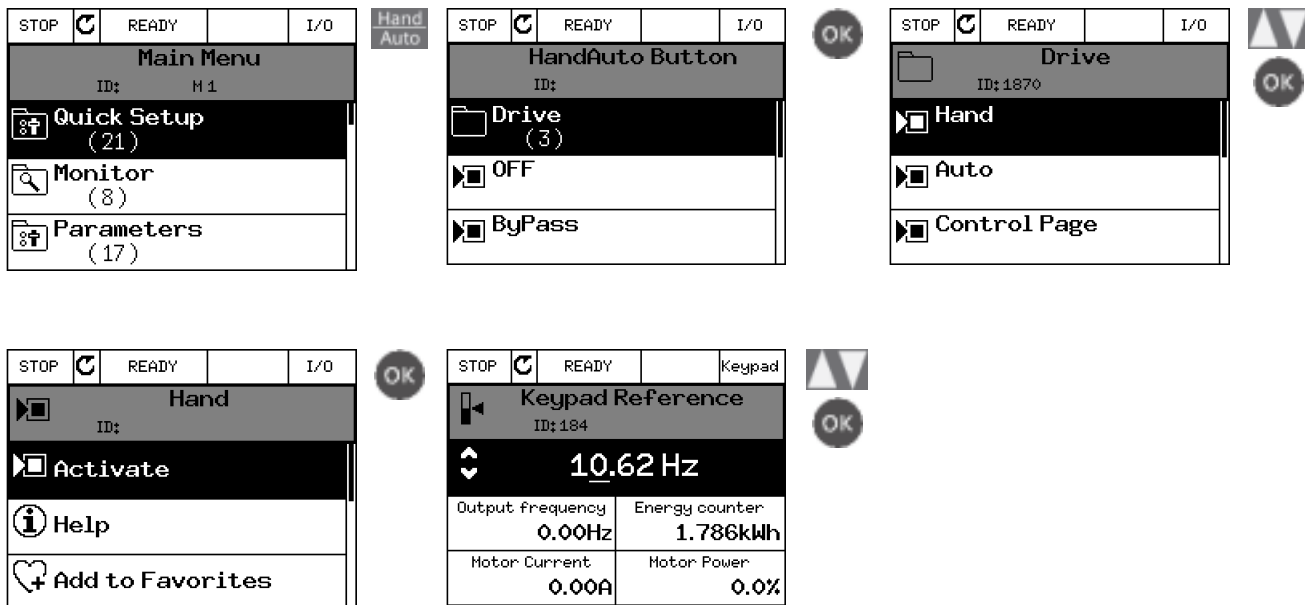

Changing the Control Place from Hand to Auto.

1. From any screen in the menu structure, press the **HAND/AUTO** button .
 - ⇒ The **HandAuto Button** menu displays with **Drive** selected.
2. Press **OK** to display the Drive menu.

3. Use the **Arrow up** or the **Arrow down** button to select **Auto** and press **OK** to confirm.
 - ⇒ The Auto menu displays with **Activate** selected.
4. Press **OK** to enter Auto mode.
 - ⇒ The control place is now in Auto mode.

Table 4: Changing the Control Place from Hand to Auto.

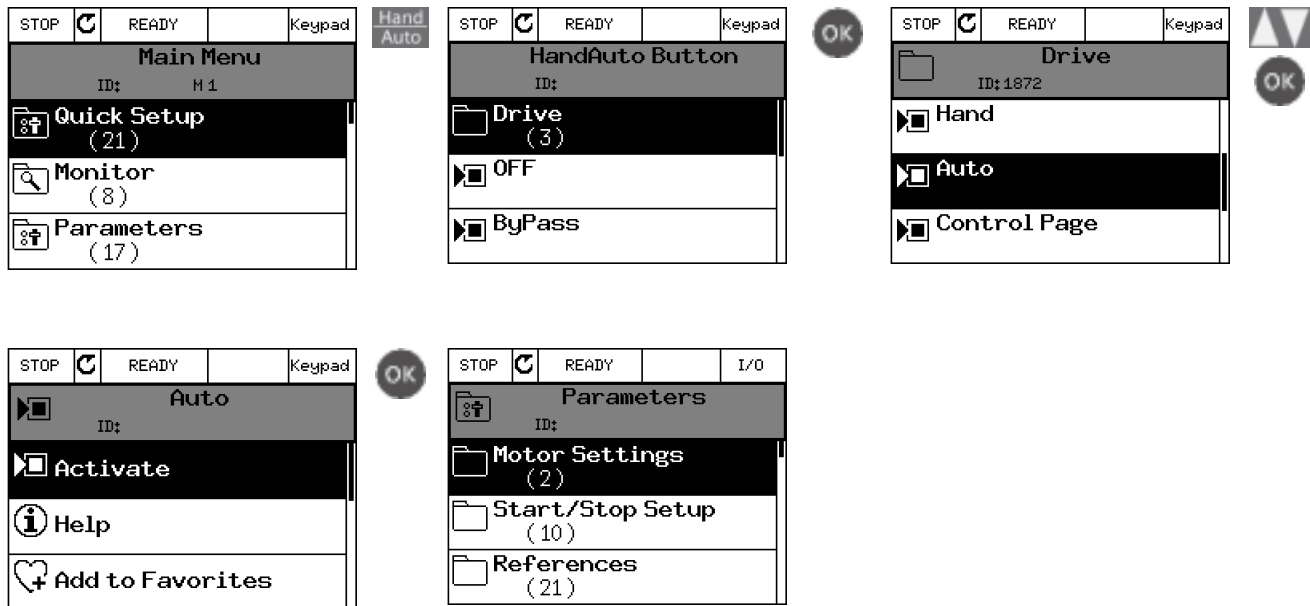

Accessing the Control Page

1. The *Control page* is meant for easy operation and monitoring of the most essential values.
2. From any screen in the menu structure, press the **HAND/AUTO** button .
 - ⇒ The **HandAuto Button** menu displays with **Drive** selected.
3. Press **OK** to display the Drive menu.
4. Use the **Arrow up** or the **Arrow down** button to select **Control Page** and press **OK** to confirm.
 - ⇒ The Control Page menu displays with **Activate** selected.
5. Press **OK**.
 - ⇒ If the keypad control place and the keypad reference are selected to be used, you can set the *Keypad reference* after pressing the *OK* button.
 - ⇒ If other control places or reference values are used, the Frequency Reference menu displays, which is not editable.

⇒ The other values on the page are Multi-monitoring values. You can choose which values display here for monitoring. For more information on this procedure, see Multi-Monitor (M2.1) [→ 31] in *Chapter 4*.

Table 5: Accessing the control page.

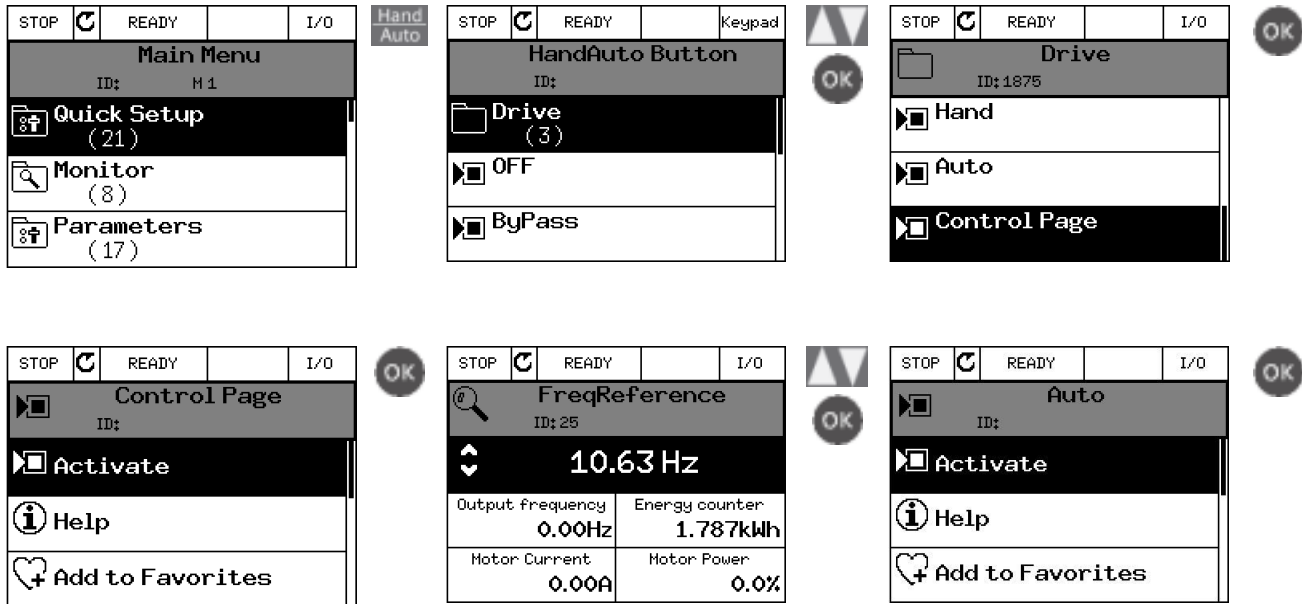

Copying parameters

The parameter copy function can be used to copy parameters from one drive to another.

The parameters are first saved to the keypad, then the keypad is detached and connected to another drive. Finally the parameters are downloaded to the new drive restoring them from the keypad.

Before any parameters can successfully be copied from one drive to another, the drive has to be stopped when the parameters are downloaded.

- First go into *User settings* menu and locate the *Parameter backup* sub-menu.
- In the *Parameter backup* sub-menu, there are three possible functions to be selected:
 - *Restore factory defaults* resets the parameters to the settings originally made at the factory.
 - *Save to keypad* allows you to copy all parameters to the keypad.
 - *Restore from keypad* copies all parameters from the keypad to a drive.

Table 6: Parameter copy.

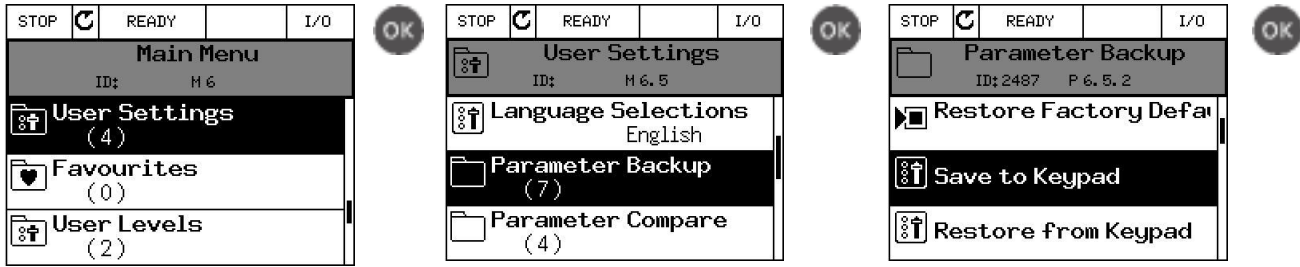

NOTE:

If the keypad is changed between drives of different sizes, the copied values of these parameters will not be used:

- Motor nominal current (P3.1.1.4)
- Motor nominal voltage (P3.1.1.1)
- Motor nominal speed (P3.1.1.3)
- Motor nominal power (P3.1.1.6)
- Motor nominal frequency (P3.1.1.2)
- Motor Cos Phi (P3.1.1.5)
- Switching frequency (P3.1.2.1)
- Motor current limit (P3.1.1.7)
- Stall current limit (P3.9.12)
- Stall time limit (P3.9.13)
- Stall frequency (P3.9.14)
- Maximum frequency (P3.3.2)

Help

The graphical keypad features instant help, and information displays for various items. All parameters offer an instant help display. Select **Help** and press the **OK** button. Text information is also available for faults, alarms and the startup wizard.

Table 7: Help text example.

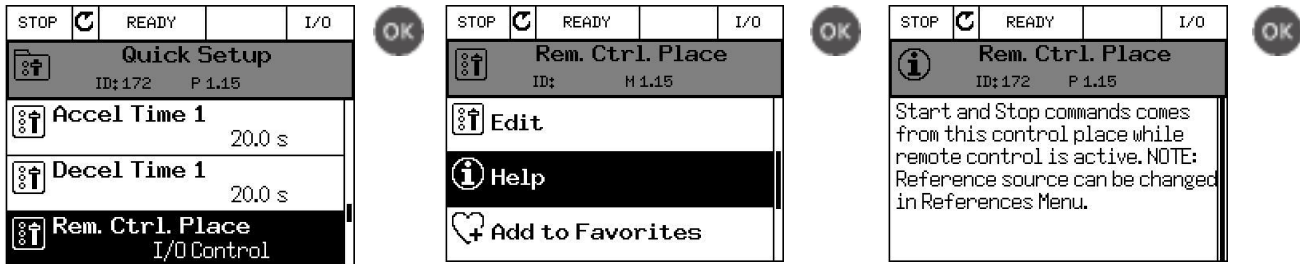

Adding an item to Favorites

You might need to refer to certain parameter values or other items often. Instead of locating them one by one in the menu structure, you may want to add them to a folder called *Favorites*, where they can easily be reached.

To remove an item from the Favorites, see Favorites (M7) [→ 94] in *Chapter 8*.

Table 8: Adding item to Favorites.

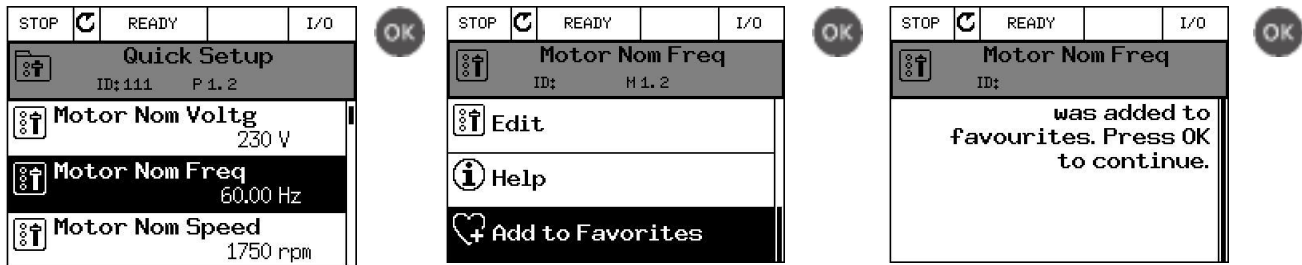

Menu structure

M1 Quick Setup	P1.17 PID Mini-Wizard	M5 I/O and Hardware	M5.1 Basic IO
	P1.18 Multipump Wizard		M5.2 Slot C
	P1.19 Startup Wizard		M5.3 Slot D
	P1.20 Fire Mode Wizard		M5.4 Slot E
	P1.21 Bypass Wizard		M5.5 Real Time Clock
M2 Monitor	M2.1 Multimonitor		M5.6 Power Unit Settings
	M2.2 Basic		M5.7 Keypad
	M2.3 Timer Functions		M5.8 RS-485
	M2.4 PID Controller 1		M5.8.1 Common Settings
	M2.5 PID Controller 2		* M5.8.3 BACnetMSTP
	M2.6 Multi-Pump	* M5.8.3 Modbus RTU	
	M2.8 Fieldbus Data	* M5.8.3 N2	
	M2.9 Temp. Inputs	* M5.8.3 P1	
M3 Parameters	M3.1 Motor Settings	* Based on Common Settings	
	M3.2 Start/Stop Setup	M5.9 Ethernet	
	M3.3 References	M5.9.1 Common Settings	
	M3.4 Ramps and Brakes	M5.9.2 Modbus TCP	
	M3.5 I/O Config	M5.9.3 BACnet IP	
	M3.6 Fieldbus DataMap	M6 User Settings	
	M3.7 Prohibit Freq		P6.1 Language Selections
	M3.8 Limit Superv		M6.5 Parameter Backup
	M3.9 Protections		M6.6 Parameter Compare
	M3.10 Automatic Reset		P6.7 Drive Name
	M3.11 Timer Function		M7 Favourites
	M3.12 PID Controller 1		
	M3.13 PID Controller 2	P8.1 User Level	
	M3.14 Multi-Pump	P8.2 Access Code	
	M3.16 Fire Mode		
	M3.17 Appl. Settings		
	M4 Diagnostics	M4.1 Active Faults	
M4.2 Reset Faults			
M4.3 Fault History			
M4.4 Total Counters			
M4.5 Trip Counters			
M4.6 Software Info			

Quick setup

The Quick Setup Menu includes the minimum set of most commonly used parameters during installation and commissioning. You can find more detailed information on the parameters of this group in Basic Settings [→ 42]

Parameters

Through this sub-menu, you can reach the application parameter groups and parameters. You can find more information on parameters in Chapter 5 - Parameters (M3) [→ 39].

Siemens NET

Siemens NET is a PC-tool for commissioning and maintenance of new generation drives (Siemens10, Siemens20, Siemens100). Siemens NET tool can be downloaded from www.Siemens.com.

Siemens NET includes the following features:

- Parameterization, monitoring, drive info, data logger, etc.
- Software download tool Siemens Loader is integrated.
- Support for RS-422 and Ethernet
- Windows 7 support
- Languages supported: English, German, Spanish, Finnish, French, Italian, Russian, Swedish, Chinese, Czech, Danish, Dutch, Polish, Portuguese, Romanian, Slovak and Turkish.
- Connection can be made by using Siemens's black USB/RS-422 cable or Ethernet cable (Siemens BT300)
- RS-422 drivers are installed automatically during the Siemens NET installation.
- When the connection is made, Siemens NET finds the connected drive automatically

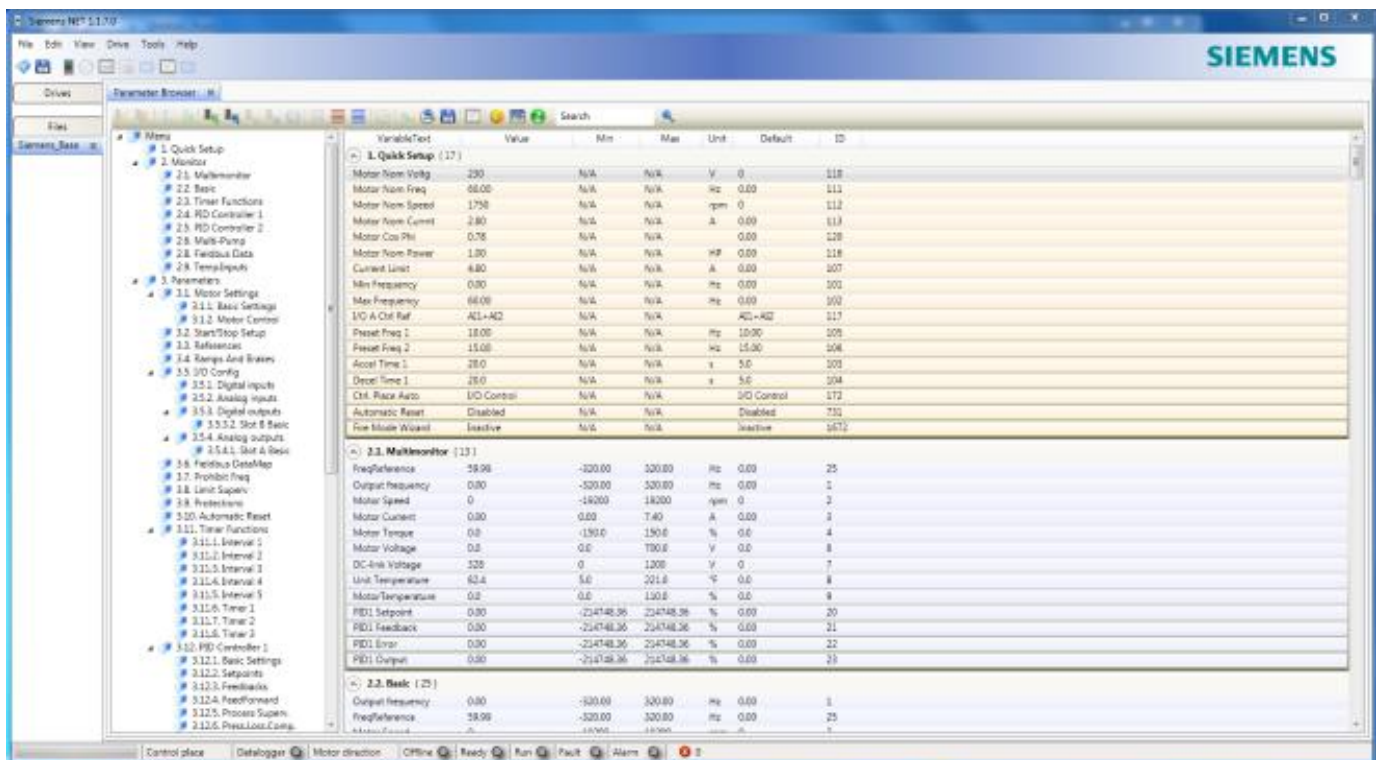

Figure 5: Siemens NET - Main Window.



NOTE:

Find more information on using Siemens NET in the program help.

Chapter 3 – Quick Setup (M1)

The Quick Setup parameter group is a collection of parameters that are most commonly used during installation and commissioning. They are collected in the first parameter group so that they can be found fast and easily. However, they can be also reached and edited in their actual parameter groups. Changing a parameter value in the Quick setup group also changes the value of this parameter in its actual group.

Table 9:

Quick setup parameter group.							
Code	Parameter	Min	Max	Unit	Default	ID	Description
P1.1	Motor nominal voltage	Varies	Varies	V	Varies	110	Find this value U_n on the rating plate of the motor. See Motor settings (M3.1) [→ 42].
P1.2	Motor nominal frequency	8.00	320.00	Hz	60.00	111	Find this value f_n on the rating plate of the motor. See Motor settings (M3.1) [→ 42].
P1.3	Motor nominal speed	24	19200	rpm	Varies	112	Find this value n_n on the rating plate of the motor.
P1.4	Motor nominal current	Varies	Varies	A	Varies	113	Find this value I_n on the rating plate of the motor.
P1.5	Motor COS PHI	0.30	1.00		Varies	120	Find this value on the rating plate of the motor.
P1.6	Motor nominal power	Varies	Varies	hp	Varies	116	Find this value I_n on the rating plate of the motor.
P1.7	Motor current limit	Varies	Varies	A	Varies	107	Maximum motor current from drive.
P1.8	Minimum frequency	0.00	P3.3.1 [→ 46]	Hz	Varies	101	Minimum allowed frequency reference.
P1.9	Maximum frequency	P3.3.1 [→ 46]	320.00	Hz	60.00	102	Maximum allowed frequency reference.
P1.10	I/O control reference A selection	1	8		6	117	Selection of ref source when control place is I/O A. See Control reference settings (M3.3) [→ 46] for selections.
P1.11	Preset frequency 1	P3.3.1 [→ 46]	300.00	Hz	10.00	105	Select with digital input: Preset frequency selection 0 (P3.5.1.15 [→ 50])
P1.12	Preset frequency 2	P3.3.1 [→ 46]	300.00	Hz	15.00	106	Select with digital input: Preset frequency selection 1 (P3.5.1.16 [→ 50])

Quick setup parameter group.							
Code	Parameter	Min	Max	Unit	Default	ID	Description
P1.13	Acceleration time 1	0.1	3000.0	s	20.0	103	Time to accelerate from zero to maximum frequency.
P1.14	Deceleration time 1	0.1	3000.0	s	20.0	104	Time to decelerate from minimum to zero frequency.
P1.15	Auto control place	1	2		1	172	Selection of Auto control place (start/stop) 1 = I/O 2 = Fieldbus
P1.16	Automatic reset	0	1		0	731	0 = Disabled 1 = Enabled
P1.17	PID Mini-Wizard	0	1		0	1803	0 = Inactive 1 = Activate See PID Mini-Wizard (P1.17) [→ 13].
P1.18	Multi-Pump Wizard	0	1		0		0 = Inactive 1 = Activate See Multi-pump Mini-wizard (P1.18) [→ 15].
P1.19	Startup Wizard	0	1		0	1171	0 = Inactive 1 = Activate See Startup Wizard (P1.19) [→ 11].
P1.20	Fire Mode Wizard	0	1	0		1672	Choosing <i>Activate</i> initiates Fire Mode Wizard (see Fire Mode Wizard (P1.20) [→ 15]).
P.1.21	Bypass Wizard	0	1		0	1823	See the <i>Siemens BT300 Bypass Operator's Manual</i> (DPD01391).

Chapter 4 - Monitor Menu (M2)

Group 2: Monitor group

The Siemens BT300 drive provides you with a possibility to monitor the actual values of parameters and signals as well as status and measurements. Some of the values to be monitored are customizable.

Multi-Monitor (M2.1)

Multi-monitor

On the multi-monitor page, you can collect nine values that you wish to monitor.

Table 10: Multi-monitoring page.

STOP	READY		I/O
Main Menu ID: M 2			
	Monitor (8)		
	Parameters (16)		
	Diagnostics (6)		
OK			
STOP	READY		I/O
Monitor ID: M 2.1			
	Multimonitor		
	Basic (28)		
	Timer Functions (10)		
OK			
STOP	READY		I/O
Multimonitor ID: 25 FreqReference			
FreqReferen	Output frequ	Motor Speed	
59.99Hz	0.00Hz	0rpm	
Motor Curren	Motor Torque	Motor Voltag	
0.00A	0.0%	0.0V	
DC-link Volta	Unit Tempera	Motor Temper.	
321V	78.8°F	0.0%	
OK			
STOP	READY		I/O
FreqReference ID: 1 V 2.1.1.24			
<input checked="" type="checkbox"/>	Output frequency		
<input checked="" type="checkbox"/>	FreqReference		
<input checked="" type="checkbox"/>	Motor Speed		
<input checked="" type="checkbox"/>	Motor Current		
<input checked="" type="checkbox"/>	Motor Torque		
<input type="checkbox"/>	Motor Power		
OK			

Change the monitored value by activating the value cell (with arrow buttons left/right) and clicking OK. Then choose a new item on the Monitoring values list and click OK again.

Basic

The basic monitoring values are the actual values of selected parameters and signals as well as statuses and measurements. Different applications may have different statuses and different number of monitoring values.

Timer functions

Monitoring of timer functions and the Real Time Clock. See Timer functions (M3.11) [→ 64].

PID Controller 1

Monitoring of PID controller values. See PID-controller 1 (M3.12) [→ 69].

PID Controller 2

Monitoring of PID controller values. See PID-controller 2 (M3.13) [→ 75].

Multi-Pump

Monitoring of values related to the use of several drives. See Multi-pump (M3.14) [→ 80].

Fieldbus data

Fieldbus data shown as monitor values for debugging purposes. For example, during fieldbus commissioning. See Fieldbus Data Mapping (M3.6) [→ 57].

Basic (M2.2)

The basic monitoring values are presented in the following Table.



NOTE:

Only Standard I/O board status are available in the Monitor menu. Status for all I/O board signals can be found as raw data in the I/O and Hardware system menu.

Check expander I/O board status when required in the I/O and Hardware system menu.

Table 11: Monitoring menu items.

Code	Monitoring value	Unit	ID	Description
V2.2.1	Output frequency	Hz	1	Output frequency to motor
V2.2.2	Frequency reference	Hz	25	Frequency reference to motor control
V2.2.3	Motor speed	rpm	2	Motor speed in rpm
V2.2.4	Motor current	A	3	
V2.2.5	Motor torque	%	4	Calculated shaft torque
V2.2.7	Motor shaft power	%	5	Total power consumption of the drive
V2.2.8	Motor shaft power	kW/hp	73	Motor shaft power in kW or hp
V2.2.9	Motor voltage	V	6	Voltage fed to the motor.
V2.2.10	DC link voltage	V	7	Voltage fed to the motor.
V2.2.11	Unit temperature	°C	8	Heat sink temperature
V2.2.12	Motor temperature	%	9	Calculated motor temperature
V2.2.13	Analog input 1	%	59	Signal in percent of used range

Code	Monitoring value	Unit	ID	Description
V2.2.14	Analog input 2	%	60	Signal in percent of used range
V2.2.15	Analog output 1	%	81	Signal in percent of used range
V2.2.16	Motor Preheat		1228	0 = OFF 1 = Heating (feeding DC-current)
V2.2.17	Drive Status Word		43	Bit coded status of drive B1 = Ready B2 = Run B3 = Fault B6 = RunEnable B7 = AlarmActive B10 = DC Current in stop B11 = DC Brake Active B12 = RunRequest B13 = MotorRegulatorActive
V2.2.18	Last active fault		37	The fault code of latest activated fault that has not been reset.
V2.2.19	Fire mode status		1597	0 = Disabled 1 = Enabled 2 = Activated (Enabled + DI open) 3 = Test mode
V2.2.20	DIN Status Word 1		56	16-bit word where each bit represents the status of one digital input. 6 digital inputs at every slot are read. Word 1 starts from input 1 in slot A (bit0) and goes to input 4 in slot C (bit15).
V2.2.21	DIN Status Word 2		57	16-bit word where each bit represents the status of one digital input. 6 digital inputs at every slot are read. Word 2 starts from input 5 in slot C (bit0) and goes to input 6 in slot E (bit13).
V2.2.22	Motor current with 1 decimal		45	Motor current monitor value with a fixed number of decimals and less filtering. Can be used e.g. for fieldbus purposes to always get the right value regardless of frame size, or monitoring when less filtering time is needed for the motor current.
V2.2.23	Appl.StatusWord 1		89	Bit coded Application Status Word 1. B0 = Interlock1 B1 = Interlock2 B5 = I/O A Control Act. B6 = I/O B Control Act. B7 = Fieldbus Control Act. B8 = Hand Control Act. B9 = PC Control Act.j B10 = Preset Frequencies Act. B12 = FireMode Act. B13 = PreHeat Act
V2.2.24	Appl.StatusWord 2		90	Bit coded Application Status Word 2. B0 = Acc/Dec Prohibited B1 = MotorSwitch Act.

Code	Monitoring value	Unit	ID	Description
V2.2.25	kWhTripCounter Low		1054	Energy counter with kWh output. (Low Word)
V2.2.26	kWhTripCounter High		1067	Determines how many times energy counter has spun around. (High Word)

Timer functions monitoring (M2.3)

Here you can monitor values of timer functions and the Real Time Clock.

Table 12: Monitoring of timer functions.

Code	Monitoring value	Unit	ID	Description
V2.3.1	TC 1, TC 2, TC 3		1441	Possible to monitor the statuses of the three Time Channels (TC)
V2.3.2	Interval 1		1442	Status of timer interval
V2.3.3	Interval 2		1443	Status of timer interval
V2.3.4	Interval 3		1444	Status of timer interval
V2.3.5	Interval 4		1445	Status of timer interval
V2.3.6	Interval 5		1446	Status of timer interval
V2.3.7	Timer 1	s	1447	Remaining time on timer if active
V2.3.8	Timer 2	s	1448	Remaining time on timer if active
V2.3.9	Timer 3	s	1449	Remaining time on timer if active
V2.3.10	Real time clock		1450	

PID Controller 1 Monitoring (M2.4)

Table 13: PID1-controller value monitoring.

Code	Monitoring value	Unit	ID	Description
V2.4.1	PID1 setpoint	Varies	20	Process units selected with parameter
V2.4.2	PID1 feedback	Varies	21	Process units selected with parameter
V2.4.3	PID1 error value	Varies	22	Process units selected with parameter
V2.4.4	PID1 output	%	23	Output to motor control or external control (AO)
V2.4.5	PID1 status		24	0 = Stopped 1 = Running 3 = Sleep mode 4 = In dead band (see page 60 [→ 69])

PID Controller 2 Monitoring (M2.5)

Table 14: PID2-controller value monitoring.

Code	Monitoring value	Unit	ID	Description
V2.5.1	PID2 setpoint	Varies	83	Process units selected with parameter
V2.5.2	PID2 feedback	Varies	84	Process units selected with parameter
V2.5.3	PID2 error value	Varies	85	Process units selected with parameter
V2.5.4	PID2 output	%	86	Output to external control (AO)
V2.5.5	PID2 status		87	0 = Stopped 1 = Running 4 = In dead band (see Basic settings [→ 69])

Multi-pump monitoring (M2.6)

Table 15: Multi-pump monitoring.

Code	Monitoring value	Unit	ID	Description
V2.6.1	Motors running		30	The number of motors running when Multi-Pump function is used.
V2.6.2	Auto-change		1114	Informs the user if auto-change is requested.

Fieldbus data monitoring (M2.8)

Table 16: Fieldbus data monitoring.

Code	Monitoring value	Unit	ID	Description
V2.8.1	FB Control Word		874	Fieldbus control word used by application in bypass mode/format. Depending on the fieldbus type or profile the data can be modified before sent to application.
V2.8.2	FB speed reference		875	Speed reference scaled between minimum and maximum frequency at the moment it was received by the application. Minimum and maximum frequencies can be changed after the reference was received without affecting the reference.
V2.8.3	FB data in 1		876	Raw value of process data in 32-bit signed format
V2.8.4	FB data in 2		877	Raw value of process data in 32-bit signed format
V2.8.5	FB data in 3		878	Raw value of process data in 32-bit signed format
V2.8.6	FB data in 4		879	Raw value of process data in 32-bit signed format

Code	Monitoring value	Unit	ID	Description
V2.8.7	FB data in 5		880	Raw value of process data in 32-bit signed format
V2.8.8	FB data in 6		881	Raw value of process data in 32-bit signed format
V2.8.9	FB data in 7		882	Raw value of process data in 32-bit signed format
V2.8.10	FB data in 8		883	Raw value of process data in 32-bit signed format
V2.8.11	FB Status Word		864	Fieldbus status word sent by application in bypass mode/format. Depending on the FB type or profile the data can be modified before sent to the FB.
V2.8.12	FB speed actual		865	Actual speed in %. 0 and 100% correspond to minimum and maximum frequencies respectively. This is continuously updated depending on the momentary min and max frequencies and the output frequency.
V2.8.13	FB data out 1		866	Raw value of process data in 32-bit signed format
V2.8.14	FB data out 2		867	Raw value of process data in 32-bit signed format
V2.8.15	FB data out 3		868	Raw value of process data in 32-bit signed format
V2.8.16	FB data out 4		869	Raw value of process data in 32-bit signed format
V2.8.17	FB data out 5		870	Raw value of process data in 32-bit signed format
V2.8.18	FB data out 6		871	Raw value of process data in 32-bit signed format
V2.8.19	FB data out 7		872	Raw value of process data in 32-bit signed format
V2.8.20	FB data out 8		873	Raw value of process data in 32-bit signed format

Temperature inputs monitoring (M2.9)

Table 17: Temperature inputs monitoring.

Code	Parameter	Min	Max	Unit	Default	ID	Description
P2.9.1	Temp.Input 1	-50.0 -58.0	200.0 398.0	°C °F	200.0 398.0	50	Measured value of Temperature Input 1. The list of temperature inputs are filled by taking the 6 first available temperature inputs starting from slot C and going to slots D and E. If input is available but no sensor is connected the maximum value is shown because measured resistance is endless.
P2.9.2	Temp.Input 2	-50.0 -58.0	200.0 398.0	°C °F	200.0 398.0	51	Measured value of Temperature Input 2. The list of temperature inputs are filled by taking the 6 first available temperature inputs starting from slot

Code	Parameter	Min	Max	Unit	Default	ID	Description
							C and going to slots D and E. If input is available but no sensor is connected the maximum value is shown because measured resistance is endless.
P2.9.3	Temp.Input 3	-50.0 -58.0	200.0 398.0	°C °F	200.0 398.0	52	Measured value of Temperature Input 3. The list of temperature inputs are filled by taking the 6 first available temperature inputs starting from slot C and going to slots D and E. If input is available but no sensor is connected the maximum value is shown because measured resistance is endless.

Chapter 5 - Parameters (M3)

Find the parameter menu and the parameter groups as guided below.

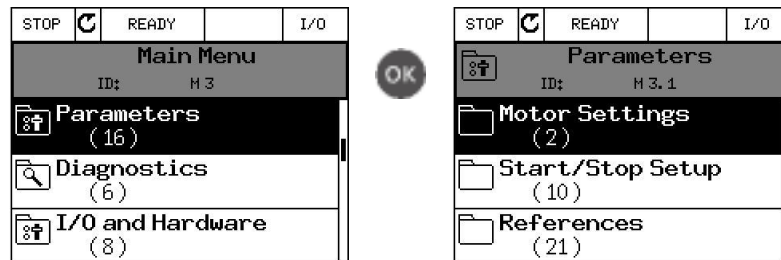

The application contains the following parameter groups:

Table 18: Parameter groups.

Menu and Parameter group	Description
Group 3.1: Motor settings [→ 42]	Basic and advanced motor settings.
Group 3.2: Start/Stop setup [→ 45]	Start and stop functions.
Group 3.3: Control reference settings [→ 46]	Frequency reference setup.
Group 3.4: Ramp & Brakes Setup [→ 49]	Acceleration/Deceleration setup.
Group 3.5: I/O Configuration [→ 50]	I/O programming
Group 3.6: Fieldbus Data Mapping [→ 57]	Process data in/out mapping
Group 3.6: Fieldbus Data Mapping [→ 57]	Fieldbus data out parameters.
Group 3.7: Prohibited Frequencies [→ 58]	Prohibit frequencies programming.
Group 3.8: Limit supervisions [→ 58]	Programmable limit controllers.
Group 3.9: Protections [→ 59]	Protections configuration
Group 3.10: Automatic reset [→ 63]	Auto reset after fault configuration.
Group 3.11: Timer functions [→ 64]	Configuration of 3 timers based on Real Time Clock.
Group 3.12: PID-controller 1 [→ 69]	Parameters for PID Controller 1. Motor control or external usage.
Group 3.13: PID-controller 2 [→ 75]	Parameters for PID Controller 2. External usage.
Group 3.14: Multi-pump [→ 80]	Parameters for multi-pump usage.
Group 3.16: Fire mode [→ 81]	Parameters for Fire Mode.

Parameter programming

Programming digital inputs in the Siemens application is very flexible. There are no digital terminals assigned only for certain functions. You can choose the terminal of your choice for the certain function; in other words, functions display as parameters for which the operator defines a certain input. For a list of the digital input functions, see the Table Digital Input Settings [→ 50].

- *Time Channels* can be assigned to digital inputs. For more information, see Digital inputs [→ 50].
- The selectable values of the programmable parameters are of type *DigIN SlotA.1* in which:

DigIN / dl' stands for digital input

Slot_' refers to the board

A and **B** are Siemens drive standard boards

C, D and **E** are option boards (see the following Figure).

The number after the board letter refers to the respective terminal on the selected board.

Hence, **SlotA.1 / A.1** means terminal **DIN1** on the standard board in board slot **A**.

- The parameter (signal) is not connected to any terminal, that is, it is not used, if, instead of a letter, the final number is preceded by a **0**. For example, **DigIN Slot0.1 / dl 0.1**.

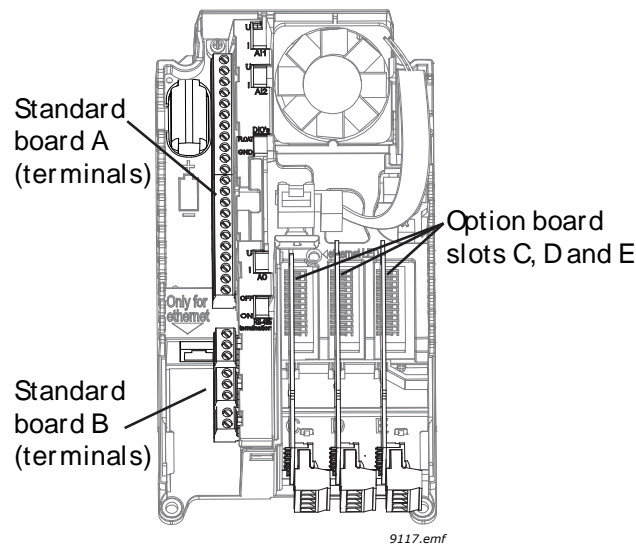

Figure 6: Option Board Slots.

Example Programming with the Graphical Keypad

Example

You want to connect the Control signal 2 A (parameter P3.5.1.2 [→ 50]) to digital input DI2 on Standard I/O board.

1	Locate the parameter Control signal 2 A (P3.5.1.2 [→ 50]) on the keypad.
---	--

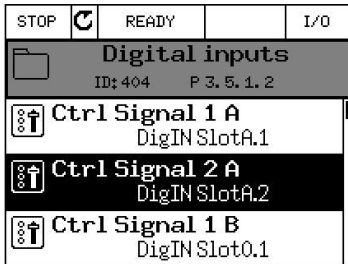
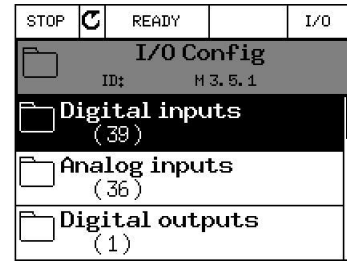
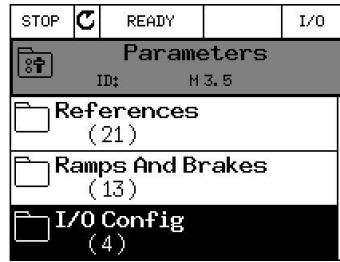
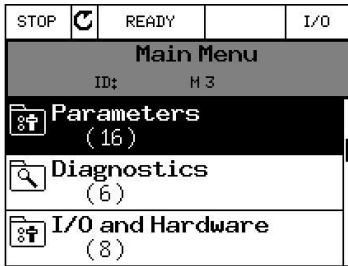

2 Enter the *Edit* mode.

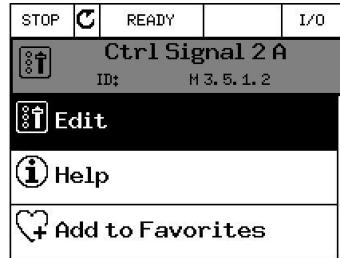
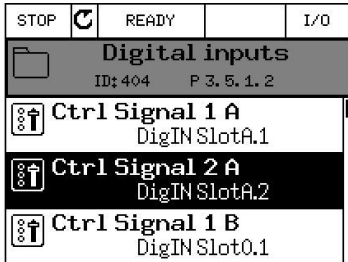

3 **Change the value:** The editable part of the value (DigIN Slot0) is underlined and blinking. Change the slot to DigIN SlotA or assign the signal to Time Channel with the arrow keys up and down. Make the terminal value (.1) editable by pressing the right key once and change the value to '2' with arrow keys up and down. Accept the change with OK button or return to previous menu level with BACK/RESET button.

Descriptions of signal sources:

Table 19: Descriptions of signal sources.

Source	Function
Slot0	1 = Always FALSE, 2-9 = Always TRUE
SlotA	Number corresponds to digital input in the slot.

SlotB	Number corresponds to digital input in the slot.
SlotC	Number corresponds to digital input in the slot.
SlotD	Number corresponds to digital input in the slot.
SlotE	Number corresponds to digital input in the slot.
TimeChannel (tCh)	1 = Time Channel1, 2 = Time Channel2, 3 = Time Channel3

Column explanations

Code	=	Location indication on the keypad; shows the operator the parameter number.
Parameter	=	Name of parameter.
Min	=	Minimum value of parameter.
Max	=	Maximum value of parameter.
Unit	=	Unit of parameter value; given if available.
Default	=	Value preset by factory.
ID	=	ID number of the parameter.
Description	=	Short description of parameter values or its function.

Motor settings (M3.1)

Basic Settings

Table 20: Basic motor settings.

Code	Parameter	Min	Max	Unit	Default	ID	Description
P3.1.1.1	Motor nominal voltage	Varies	Varies	V	Varies	110	Find this value U_n (V) on the rating plate of the motor. This parameter sets the voltage at the field weakening point to $100\% * U_n$ (V) _{Motor} . Note also used connection (Delta/Star).
P3.1.1.2	Motor nominal frequency	8.00	320.00	Hz	Varies	111	Find this value f_n on the rating plate of the motor. This parameter sets the field weakening point (P3.1.2.3 [→ 43]) to the same value.

Code	Parameter	Min	Max	Unit	Default	ID	Description
P3.1.1.3	Motor nominal speed	24	19200	rpm	Varies	112	Find this value n_n on the rating plate of the motor.
P3.1.1.4	Motor nominal current	Varies	Varies	A	Varies	113	Find this value I_n on the rating plate of the motor.
P3.1.1.5	Motor Cos Phi	0.30	1.00		Varies	120	Find this value on the rating plate of the motor
P3.1.1.6	Motor nominal power	Varies	Varies	hp	Varies	116	Find this value I_n on the rating plate of the motor.
P3.1.1.7	Motor current limit	Varies	Varies	A	Varies	107	Maximum motor current from drive. Also see page [→ 97]
P3.1.1.8	Motor type	0	1		0	650	Select what motor type is used. 0 = asynchronous induction motor, 1 = PM synchronous motor.

Motor Control Settings

Table 21: Advanced motor settings.

Code	Parameter	Min	Max	Unit	Default	ID	Description
P3.1.2.1	Switching frequency	1.5	Varies	kHz	Varies	601	Motor noise can be minimized using a high switching frequency. Increasing the switching frequency reduces the capacity of the drive. It is recommended to use a lower frequency when the motor cable is long in order to minimize capacitive currents in the cable.
P3.1.2.2	Motor switch	0	1		0	653	Enabling this function prevents the drive from tripping when the motor switch is closed and opened using flying start for example. 0 = Disabled 1 = Enabled
P3.1.2.4	Zero frequency voltage	0.00	40.00	%	Varies	606	This parameter defines the zero frequency voltage of the U/f curve. The default value varies according to unit size.
P3.1.2.5	Motor preheat function	0	3		0	1225	0 = Not used 1 = Always in stop state 2 = Controlled by DI 3 = Temp limit (heat sink) NOTE: Virtual digital input can be activated by Real Time

Code	Parameter	Min	Max	Unit	Default	ID	Description
							Clock
P3.1.2.6	Motor preheat temperature limit	-20	80	°F	0	1226	Motor preheat is switched on when the heat sink temperature goes below this level (if par. P3.1.2.5 [→ 43] is set to <i>Temperature limit</i> . If limit is e.g. 10°C (50°F) feeding current starts at 10°C and stops at 11°C (51.8°) (1°C (1.8°F) hysteresis).
P3.1.2.7	Motor preheat current	0	0.5*IL	A	Varies	1227	DC current for pre-heating of motor and drive in stop state. Activated by digital input or by temperature limit.
P3.1.2.9	U/f ratio selection [→ 97]	0	1		Varies	108	Type of U/f curve between zero frequency and the field weakening point. 0 = Linear 1 = Squared
P3.1.2.15	Over-voltage controller [→ 97]	0	1		1	607	0 = Disabled 1 = Enabled
P3.1.2.16	Under-voltage controller [→ 97]	0	1		1	608	0 = Disabled 1 = Enabled
P3.1.2.17	StatorVoltAdjust	50.0%	150.0%		100.0	659	Parameter for adjusting stator voltage in permanent magnet motors.
P3.1.2.18	Energy optimization	0	1		0	666	The drive searches for the minimum motor current in order to save energy and to lower the motor noise. This function can be used for example in fan and pump applications 0 = Disabled 1 = Enabled
P3.1.2.19	Flying Start Options	0	1		0	1590	0 = Shaft direction is searched in both directions. 1 = Shaft direction is only searched in the same direction as the frequency reference
P3.1.2.2	Brake chopper					504	
P3.1.2.3	Identification run					631	0=No action 1=Identification w/o run 2=Identification with run
P3.1.2.4	Motor preheat	0	3		0		0=Not used 1=Always in stop state 2=Controlled by digital input 3=Temperature limit (heatsink)

Code	Parameter	Min	Max	Unit	Default	ID	Description
							NOTE: Virtual digital input can be activated from RTC
P3.1.2.5	Motor preheat temperature level			°C			Motor preheat is switched on when heatsink temperature goes below this level
P3.1.2.6	Motor preheat current			A			DC-brake current for pre-heating of motor and drive in Stop state. Activated by digital input or by temperature limit.

Start/Stop setup (M3.2)

Start/Stop commands are given differently depending on the control place.

Auto control place (I/O A): Start, stop and reverse commands are controlled by 2 digital inputs chosen with parameters P3.5.1.1 [→ 50] and P3.5.1.2 [→ 50]. The functionality/logic for these inputs is then selected with parameter P3.2.6 [→ 45] (in this group).

Auto control place (I/O B): Start, stop and reverse commands are controlled by 2 digital inputs chosen with parameters P3.5.1.3 [→ 50] and P3.5.1.4 [→ 50]. The functionality/logic for these inputs is then selected with parameter P3.2.7 [→ 45] (in this group).

Hand control place (Keypad): Start and stop commands come from the keypad buttons, while the direction of rotation is selected by the parameter P3.3.7 [→ 46].

Auto control place (Fieldbus): Start, stop and reverse commands come from fieldbus.

Table 22: Start/Stop Setup menu.

Code	Parameter	Min	Max	Unit	Default	ID	Description
P3.2.1	Auto control place	0	1		0	172	Selection of auto control place (start/stop). 0 = I/O control 1 = Fieldbus control
P3.2.2	Hand/Auto	0	1		0	211	Switch between Hand and Auto control places 0 = Auto 1 = Hand
P3.2.3	Keypad stop button	0	1		0	114	0 = Stop button always enabled (Yes) 1 = Limited function of Stop button (No)
P3.2.4	Start function	0	1		Varies	505	0 = Ramping 1 = Flying start
P3.2.5	Stop function	0	1		0	506	0 = Coasting 1 = Ramping

Code	Parameter	Min	Max	Unit	Default	ID	Description
P3.2.6	I [→ 97]/O A start/stop logic	0	4		0	300	<i>Logic = 0:</i> Ctrl sgn 1 = Forward Ctrl sgn 2 = Backward <i>Logic = 1:</i> Ctrl sgn 1 = Forward (edge) Ctrl sgn 2 = Inverted Stop <i>Logic = 2:</i> Ctrl sgn 1 = Forward (edge) Ctrl sgn 2 = Bckwrđ (edge) <i>Logic = 3:</i> Ctrl sgn 1 = Start Ctrl sgn 2 = Reverse <i>Logic = 4:</i> Ctrl sgn 1 = Start (edge) Ctrl sgn 2 = Reverse
P3.2.7	I/O B start/stop logic	0	4		0	363	See above.
P3.2.7	AI1 start threshold	3.00	100.00	%	5.00	185	Threshold level to start the drive when start/stop logic is set to 5.
P3.2.8	Fieldbus start logic	0	1		0	889	0 = Rising edge required 1 = State
P3.2.9	Start delay	0.00	10.00	s	0.00	524	Delay time before final Run request to motor control after Start request is given NOTE: Delay time longer than 10s can be dangerous!

Control reference settings (M3.3)

The frequency reference source is programmable for all control places except *PC*, which always takes the reference from the PC tool.

Auto control place (I/O A): The source of frequency reference can be selected with parameter P3.3.3 [→ 46].

Auto control place (I/O B): The source of frequency reference can be selected with parameter P3.3.4 [→ 46].

Hand control place (Keypad): If the default selection for parameter P3.3.5 [→ 46] is used the reference set with parameter P3.3.6 [→ 46] applies.

Auto control place (Fieldbus): The frequency reference comes from fieldbus if the default value for parameter P3.3.9 [→ 46] is kept.

Table 23: Control reference settings.

Code	Parameter	Min	Max	Unit	Default	ID	Description
P3.3.1	Minimum frequency	0.00	P3.3.2 [→ 46]	Hz	0.00	101	Minimum allowed frequency reference
P3.3.2	Maximum frequency	P3.3.1 [→ 46]	320.00	Hz	60.00	102	Maximum allowed frequency reference

Code	Parameter	Min	Max	Unit	Default	ID	Description
P3.3.3	I/O control reference A selection	1	8		6	117	Selection of ref source when control place is I/O A 1 = Preset Frequency 0 2 = Keypad reference 3 = Fieldbus 4 = AI1 5 = AI2 6 = AI1+AI2 7 = PID 1 reference 8 = Motor potentiometer
P3.3.4	I/O control reference B selection	1	8		4	131	Selection of ref source when control place is I/O B. See above. NOTE : I/O B control place can only be forced active with digital input (P3.5.1.5 [→ 50]).
P3.3.5	Keypad Control Reference selection	1	8		2	121	Selection of ref source when control place is keypad: 1 = Preset Frequency 0 2 = Keypad 3 = Fieldbus 4 = AI1 5 = AI2 6 = AI1+AI2 7 = PID 1 reference 8 = Motor potentiometer
P3.3.6	Keypad reference	0.00	P3.3.2 [→ 46]	Hz	0.00	184	The frequency reference can be adjusted on the keypad with this parameter.
P3.3.7	Keypad direction	0	1		0	123	Motor rotation when control place is keypad 0 = Forward 1 = Reverse
P3.3.8	Keypad reference copy	0	2		1	181	Selects function for Run state & Reference copy when changing to Keypad control: 0 = Copy reference 1 = Copy ref & Run State 2 = No copying
P3.3.9	Fieldbus control reference selection	1	8		3	122	Selection of ref source when control place is Fieldbus: 1 = Preset frequency 0 2 = Keypad 3 = Fieldbus 4 = AI1 5 = AI2 6 = AI1+AI2 7 = PID 1 reference 8 = Motor potentiometer

Code	Parameter	Min	Max	Unit	Default	ID	Description
P3.3.10	Preset frequency mode	0	1		0	182	0 = Binary coded 1 = Number of inputs. Preset frequency is selected according to how many of preset speed digital inputs are active
P3.3.11	Preset frequency 0	P3.3.1	P3.3.2	Hz	5.00	180	Basic preset frequency 0 when selected by Control reference parameter (P3.3.3 [→ 46]).
P3.3.12	Preset frequency 1	P3.3.1	P3.3.2	Hz	10.00	105	Select with digital input: Preset frequency selection 0 (P3.5.1.15 [→ 50])
P3.3.13	Preset frequency 2	P3.3.1	P3.3.2	Hz	15.00	106	Select with digital input: Preset frequency selection 1 (P3.5.1.16 [→ 50])
P3.3.14	Preset frequency 3	P3.3.1	P3.3.2	Hz	20.00	126	Select with digital inputs: Preset frequency selection 0 & 1.
P3.3.15	Preset frequency 4	P3.3.1	P3.3.2	Hz	25.00	127	Select with digital input: Preset frequency selection 2 (P3.5.1.17 [→ 50])
P3.3.16	Preset frequency 5	P3.3.1	P3.3.2	Hz	30.00	128	Select with digital inputs: Preset frequency selection 0 & 2.
P3.3.17	Preset frequency 6	P3.3.1	P3.3.2	Hz	40.00	129	Select with digital inputs: Preset frequency selection 1 & 2.
P3.3.18	Preset frequency 7	P3.3.1	P3.3.2	Hz	50.00	130	Select with digital inputs: Preset frequency selection 0 & 1 & 2.
P3.3.19	Preset alarm frequency	P3.3.1	P3.3.2	Hz	25.00	183	This frequency used when fault response (in Group 3.9: Protections [→ 59]) is Alarm+preset frequency.
P3.3.20	Motor potentiometer ramp time	0.1	500.0	Hz/s	10.0	331	Rate of change in the motor potentiometer reference when increased or decreased.
P3.3.21	Motor potentiometer reset	0	2		1	367	Motor potentiometer frequency reference reset logic. 0 = No reset 1 = Reset if stopped 2 = Reset if powered down

Ramp & Brakes Setup (M3.4)

Two ramps are available (two sets of acceleration time, deceleration time and ramp shape). The second ramp can be activated by a digital input.

NOTE:

Ramp 2 always has higher priority and is used if a digital input for ramp selection is activated or the Ramp 2 threshold is smaller than RampFreqOut.

Table 24: Ramp and brakes setup.

Code	Parameter	Min	Max	Unit	Default	ID	Description
P3.4.1	Ramp 1 shape	0.0	10.0	s	0.0	500	S-curve time ramp 1
P3.4.2	Acceleration time 1	0.1	3000.0	s	20.0	103	Defines the time required for the output frequency to increase from zero frequency to maximum frequency.
P3.4.3	Deceleration time 1	0.1	3000.0	s	20.0	104	Defines the time required for the output frequency to decrease from maximum frequency to zero frequency.
P3.4.4	Ramp 2 shape	0.0	10.0	s	0.0	501	S-curve time ramp 2. See P3.4.1 [→ 49].
P3.4.5	Acceleration time 2	0.1	3000.0	s	10.0	502	See P3.4.2 [→ 49].
P3.4.6	Deceleration time 2	0.1	3000.0	s	10.0	503	See P3.4.3 [→ 49].
P3.4.7	Start magnetizing time	0,00	600,00	s	0,00	516	This parameter defines the time for how long DC current is fed to motor before acceleration starts.
P3.4.8	Start magnetizing current	Varies	Varies	A	Varies	517	
P3.4.9	DC braking time at stop	0,00	600,00	s	0,00	508	Determines if braking is ON or OFF and the braking time of the DC-brake when the motor is stopping.
P3.4.10	DC brake current	Varies	Varies	A	Varies	507	Defines the current injected into the motor during DC-braking. 0 = Disabled
P3.4.11	Frequency to start DC braking at ramp stop	0,10	10,00	Hz	1,50	515	The output frequency at which the DC-braking is applied.
P3.4.12	Flux braking	0	1		0	520	0 = Disabled 1 = Enabled
P3.4.13	Flux braking current	0	Varies	A	Varies	519	Defines the current level for flux braking.

I/O Configuration (M3.5)

Digital inputs

Digital inputs are very flexible to use. Parameters are functions that are connected to the required digital input terminal. The digital inputs are represented as, for example, *DigIN Slot A.2*, meaning the second input on slot A.

It is also possible to connect the digital inputs to time channels which are also represented as terminals.

NOTE:

The status of digital inputs and the digital output can be monitored in the Multi-monitoring view. See Multi-Monitor (M2.1) [→ 31].

Table 25: Digital Input Settings.

Code	Parameter	Default	ID	Description
P3.5.1.1	Control signal 1 A	DigIN SlotA.1	403	Start signal 1 when control place is I/O 1 (FWD)
P3.5.1.2	Control signal 2 A	DigIN Slot0.1	404	Start signal 2 when control place is I/O 1 (REV)
P3.5.1.3	Control signal 1 B	DigIN Slot0.1	423	Start signal 1 when control place is I/O B
P3.5.1.4	Control signal 2 B	DigIN Slot0.1	424	Start signal 2 when control place is I/O B
P3.5.1.5	I/O B control force	DigIN Slot0.1	425	TRUE = Force the control place to I/O B
P3.5.1.6	I/O B reference force	DigIN Slot0.1	343	TRUE = Used frequency reference is specified by I/O reference B parameter (P3.3.4 [→ 46]).
P3.5.1.7	External fault close	DigIN SlotA.3	405	FALSE = OK TRUE = External fault
P3.5.1.8	External fault open	DigIN Slot0.2	406	FALSE = External fault TRUE = OK
P3.5.1.9	Fault reset Close	DigIN SlotA.6	414	Resets all active faults (rising edge)
P3.5.1.10	Fault Reset Open	DigIN Slot0.1	213	Reset all active faults (falling edge)
P3.5.1.11	Run enable	DigIN Slot0.2	407	Must be on to set drive in Ready state
P3.5.1.12	Run interlock 1	DigIN Slot0.1	1041	Drive will not start before this input is activated (Damper interlock).
P3.5.1.13	Run interlock 2	DigIN Slot0.1	1042	As above.
P3.5.1.14	Motor preheat ON	DigIN Slot0.1	1044	FALSE = No action TRUE = Uses the motor preheat DC-Current in Stop state Used when parameter P3.1.2.5 [→ 43] is set to 2.
P3.5.1.15	Preset frequency	DigIN SlotA.4	419	Binary selector for Preset speeds (0-7).

Code	Parameter	Default	ID	Description
	selection 0			See page [→ 46].
P3.5.1.16	Preset frequency selection 1	DigIN SlotA.5	420	Binary selector for Preset speeds (0-7). See page [→ 46].
P3.5.1.17	Preset frequency selection 2	DigIN Slot0.1	421	Binary selector for Preset speeds (0-7). See page [→ 46].
P3.5.1.18	Timer 1	DigIN Slot0.1	447	Rising edge starts Timer 1 programmed in Group 3.11: Timer functions [→ 64] parameter group
P3.5.1.19	Timer 2	DigIN Slot0.1	448	See above
P3.5.1.20	Timer 3	DigIN Slot0.1	449	See above
P3.5.1.21	Disable timer function	DigIN Slot0.1	1499	
P3.5.1.22	PID1 setpoint boost	DigIN Slot0.1	1047	FALSE = No boost TRUE = Boost
P3.5.1.23	PID1 select setpoint	DigIN Slot0.1	1046	FALSE = Setpoint 1 TRUE = Setpoint 2
P3.5.1.24	PID2 start signal	DigIN Slot0.2	1049	FALSE = PID2 in stop mode TRUE = PID2 regulating This parameter will have no effect if PID2 controller is not enabled in the Basic menu for PID2
P3.5.1.25	PID2 select setpoint	DigIN Slot0.1	1048	FALSE = Setpoint 1 TRUE = Setpoint 2
P3.5.1.26	Motor 1 interlock	DigIN Slot0.1	426	FALSE = Not active TRUE = Active
P3.5.1.27	Motor 2 interlock	DigIN Slot0.1	427	FALSE = Not active TRUE = Active
P3.5.1.28	Motor 3 interlock	DigIN Slot0.1	428	FALSE = Not active TRUE = Active
P3.5.1.29	Motor 4 interlock	DigIN Slot0.1	429	FALSE = Not active TRUE = Active
P3.5.1.30	Motor 5 interlock	DigIN Slot0.1	430	
P3.5.1.31	Motor potentiometer UP	DigIN Slot0.1	418	FALSE = Not active TRUE = Active (Motor potentiometer reference INCREASES until the contact is opened)
P3.5.1.32	Motor potentiometer DOWN	DigIN Slot0.1	417	FALSE = Not active TRUE = Active (Motor potentiometer reference DECREASES until the contact is opened)
P3.5.1.33	Accel/Decel Time selection	DigIN Slot0.1	408	Used for switching between ramp 1 and 2. OPEN = Ramp1 shape, acceleration time 1 and deceleration time 1. CLOSED = Ramp2 shape, acceleration time 2 and

Code	Parameter	Default	ID	Description
				deceleration time 2.
P3.5.1.34	Fieldbus control	DigIN Slot0.1	411	TRUE = Forces control place to fieldbus.
P3.5.1.39	Fire Mode Active Open	DigIN Slot0.2	1569	
P3.5.1.40	Fire Mode Active Close	DigIN Slot0.1	1619	
P3.5.1.41	Fire mode reverse	DigIN Slot0.1	1618	Reverse command of rotation direction while running in Fire Mode. This function has no effect in normal operation. FALSE = Forward TRUE = Reverse
P3.5.1.42	Keypad Control	DigIN Slot0.1	410	
P3.5.1.43	Reset kWh Trip Counter	DigIN Slot0.1	1053	Reset kWh Trip Counter

Analog inputs

Table 26: Analog Input Settings.

Code	Parameter	Min	Max	Unit	Default	ID	Description
P3.5.2.1	AI1 signal selection				AnIN SlotA.1	377	Connect the AI1 signal to the analog input of your choice with this parameter. Programmable
P3.5.2.2	A [→ 97]1 signal filter time	0.00	300.00	s	1.0	378	Filter time for analog input
P3.5.2.3	AI1 signal range	0	1		0	379	0 = 0...10 V / 0...20 mA 1 = 2...10 V / 4...20 mA
P3.5.2.4	AI1 custom. min	-160.00	160.00	%	0.00	380	Custom range min setting 20% = 4-20 mA/2-10 V
P3.5.2.5	AI1 custom. max	-160.00	160.00	%	100.00	381	Custom range max setting
P3.5.2.6	AI1 signal inversion	0	1		0	387	0 = Normal 1 = Signal inverted
P3.5.2.7	AI2 signal selection				AnIN SlotA.2	388	See P3.5.2.1 [→ 52].
P3.5.2.8	AI2 signal filter time	0.00	300.00	s	1.0	389	See P3.5.2.2 [→ 52].
P3.5.2.9	AI2 signal range	0	1		1	390	0 = 0...10 V / 0...20 mA 1 = 2...10 V / 4...20 mA
P3.5.2.10	AI2 custom. min	-160.00	160.00	%	0.00	391	See P3.5.2.4 [→ 52].
P3.5.2.11	AI2 custom. max	-160.00	160.00	%	100.00	392	See P3.5.2.5 [→ 52].

Code	Parameter	Min	Max	Unit	Default	ID	Description
P3.5.2.12	AI2 signal inversion	0	1		0	398	See P3.5.2.6 [→ 52].
P3.5.2.13	AI3 signal selection				AnIN Slot0.1	141	Connect the AI3 signal to the analog input of your choice with this parameter. Programmable
P3.5.2.14	AI3 signal filter time	0.00	300.00	s	1.0	142	Filter time for analog input
P3.5.2.15	AI3 signal range	0	1		0	143	0 = 0...10 V / 0...20 mA 1 = 2...10 V / 4...20 mA
P3.5.2.16	AI3 custom. min	-160.00	160.00	%	0.00	144	20% = 4-20 mA/2-10 V
P3.5.2.17	AI3 custom. max	-160.00	160.00	%	100.00	145	Custom range max setting
P3.5.2.18	AI3 signal inversion	0	1		0	151	0 = Normal 1 = Signal inverted
P3.5.2.19	AI4 signal selection				AnIN Slot0.1	152	See P3.5.2.13 [→ 52]. Programmable
P3.5.2.20	AI4 signal filter time	0.00	300.00	s	1.0	153	See P3.5.2.14 [→ 52].
P3.5.2.21	AI4 signal range	0	1		0	154	0 = 0...10 V / 0...20 mA 1 = 2...10 V / 4...20 mA
P3.5.2.22	AI4 custom. min	-160.00	160.00	%	0.00	155	See P3.5.2.16 [→ 52].
P3.5.2.23	AI4 custom. max	-160.00	160.00	%	100.00	156	See P3.5.2.17 [→ 52].
P3.5.2.24	AI4 signal inversion	0	1		0	162	See P3.5.2.18 [→ 52].
P3.5.2.25	AI5 signal selection				AnIN Slot0.1	188	Connect the AI5 signal to the analog input of your choice with this parameter. Programmable.
P3.5.2.26	AI5 signal filter time	0.00	300.00	s	1.0	189	Filter time for analog input
P3.5.2.27	AI5 signal range	0	1		0	190	0 = 0...10 V / 0...20 mA 1 = 2...10 V / 4...20 mA
P3.5.2.28	AI5 custom. min	-160.00	160.00	%	0.00	191	20% = 4-20 mA/2-10 V
P3.5.2.29	AI5 custom. max	-160.00	160.00	%	100.00	192	Custom range max setting
P3.5.2.30	AI5 signal inversion	0	1		0	198	0 = Normal 1 = Signal inverted
P3.5.2.31	AI6 signal selection				AnIN Slot0.1	199	See P3.5.2.13 [→ 52]. Programmable
P3.5.2.32	AI6 signal filter time	0.00	300.00	s	1.0	200	See P3.5.2.14 [→ 52].

Code	Parameter	Min	Max	Unit	Default	ID	Description
P3.5.2.33	AI6 signal range	0	1		0	201	0 = 0...10 V / 0...20 mA 1 = 2...10 V / 4...20 mA
P3.5.2.34	AI6 custom. min	-160.00	160.00	%	0.00	203	See P3.5.2.16 [→ 52].
P3.5.2.35	AI6 custom. max	-160.00	160.00	%	100.00	204	See P3.5.2.17 [→ 52].
P3.5.2.36	AI6 signal inversion	0	1		0	209	See P3.5.2.18 [→ 52].

Digital outputs, slot B (Basic)

Table 27: Digital output settings on standard I/O board.

Code	Parameter	Min	Max	Unit	Default	ID	Description
P3.5.3.2.1	Basic RO1 function	0	35		2	11001	Function selection for Basic RO1: 0 = None 1 = Ready 2 = Run 3 = General fault 4 = General fault inverted 5 = General alarm 6 = Reversed 7 = At speed 8 = Motor regulator active 9 = Preset speed active 10 = Keypad control active 11 = I/O B control activated 12 = Limit supervision 1 13 = Limit supervision 2 14 = Start signal active 15 = Reserved 16 = Fire Mode activation 17 = RTC time chnl 1 control 18 = RTC time chnl 2 control 19 = RTC time chnl 3 control 20 = FB ControlWord B13 21 = FB ControlWord B14 22 = FB ControlWord B15 23 = PID1 in Sleep mode 24 = Reserved 25 = PID1 supervision limits 26 = PID2 supervision limits 27 = Motor 1 control 28 = Motor 2 control 29 = Motor 3 control 30 = Motor 4 control 31 = Motor 5 control 32 = Reserved (Always open) 33 = Reserved (Always open) 34 = Maintenance alarm 35 = Maintenance fault 36 = Thermistor fault 37 = Motor switch 38 = Bypass active 39 = Bypass running

Code	Parameter	Min	Max	Unit	Default	ID	Description
							40 = Drive active 41 = Drive output contactor 42 = Overload fault 43 = Essential Services active 44 = Auto bypass active 45 = Interlock proofing 46 = Interlock proofed 47 = Stop forced 48 = Remote start
P3.5.3.2.2	Basic RO1 ON delay	0.00	320.00	s	0.00	11002	ON delay for relay
P3.5.3.2.3	Basic RO1 OFF delay	0.00	320.00	s	0.00	11003	OFF delay for relay
P3.5.3.2.4	Basic RO2 function	0	35		3	11004	See P3.5.3.2.1 [→ 54]
P3.5.3.2.5	Basic RO2 ON delay	0.00	320.00	s	0.00	11005	See P3.5.3.2.2 [→ 54].
P3.5.3.2.6	Basic RO2 OFF delay	0.00	320.00	s	0.00	11006	See P3.5.3.2.3 [→ 54].
P3.5.3.2.7	Basic RO3 function	0	35		1	11007	See P3.5.3.2.1 [→ 54]. Not visible if only 2 output relays are installed

Expander slots C, D, and E digital outputs

Table 28: Slot C, D, E Digital Outputs.

Code	Parameter	Min	Max	Unit	Default	ID	Description
	Application dynamic output list						Shows only parameters for existing outputs in slots C, D, and E. Selections as in Basic RO1 Not visible if no digital output exists in slot C, D, or E.

Analog outputs, Slot A (Standard)

Table 29: Standard I/O board analog output settings.

Code	Parameter	Min	Max	Unit	Default	ID	Description
P3.5.4.1.1	AO1 function	0	19		2	10050	0 = TEST 0% (Not used) 1 = TEST 100% 2 = Output freq (0 -fmax) 3 = Freq reference (0-fmax) 4 = Motor speed (0 - Motor nominal speed) 5 = Output current (0-InMotor) 6 = Motor torque (0-TnMotor) 7 = Motor power (0-PnMotor) 8 = Motor voltage (0-UnMotor)

Code	Parameter	Min	Max	Unit	Default	ID	Description
							9 = DC link voltage (0-1000V) 10 = PID1 output (0-100%) 11 = PID2 output (0-100%) 12 = ProcessDataIn1 13 = ProcessDataIn2 14 = ProcessDataIn3 15 = ProcessDataIn4 16 = ProcessDataIn5 17 = ProcessDataIn6 18 = ProcessDataIn7 19 = ProcessDataIn8 Note: For ProcessDataIn, e.g. value 5000 = 50.00%
P3.5.4.1.2	AO1 filter time	0.00	300.00	s	1.00	10051	Filtering time of analog output signal. See P3.5.2.2 [→ 52] 0 = No filtering
P3.5.4.1.3	AO1 minimum	0	1		0	10052	0 = 0 mA / 0 V 1 = 4 mA / 2 V Note the difference in analog output scaling in parameter P3.5.4.1.4 [→ 55].
P3.5.4.1.4	AO1 minimum scale	Varies	Varies	Varies	0.0	10053	Min scale in process unit (depends on selection of AO1 function)
P3.5.4.1.5	AO1 maximum scale	Varies	Varies	Varies	0.0	10054	Max scale in process unit (depends on selection of AO1 function)

Expander slots C, D, and E Analog Outputs

Table 30: Slots C, D, and E analog outputs.

Code	Parameter	Min	Max	Unit	Default	ID	Description
	Application dynamic output list						Shows only parameters for existing outputs in slot C, D, and E. Selections as in Basic AO1 Not visible if no analog output exists in slot C, D, or E.

Fieldbus Data Mapping (M3.6)

Table 31: Fieldbus data mapping.

Code	Parameter	Min	Max	Unit	Default	ID	Description
P3.6.1	Fieldbus data out 1 selection	0	35000		1	852	Data sent to fieldbus can be chosen with parameter and monitor value ID numbers. The data is scaled to unsigned 16-bit format according to the format on keypad. E.g. 25.5 on keypad equals 255.
P3.6.2	Fieldbus data out 2 selection	0	35000		2	853	Select Process Data Out with parameter ID.
P3.6.3	Fieldbus data out 3 selection	0	35000		45	854	Select Process Data Out with parameter ID.
P3.6.4	Fieldbus data out 4 selection	0	35000		4	855	Select Process Data Out with parameter ID.
P3.6.5	Fieldbus data out 5 selection	0	35000		5	856	Select Process Data Out with parameter ID.
P3.6.6	Fieldbus data out 6 selection	0	35000		6	857	Select Process Data Out with parameter ID.
P3.6.7	Fieldbus data out 7 selection	0	35000		7	858	Select Process Data Out with parameter ID.
P3.6.8	Fieldbus data out 8 selection	0	35000		37	859	Select Process Data Out with parameter ID.

Fieldbus process data out

Values to monitor through fieldbus are:

Table 32: Fieldbus Process Data Out.

Data	Value	Scale
Process Data Out 1	Output frequency	0.01 Hz
Process Data Out 2	Motor speed	1 rpm
Process Data Out 3	Motor current	0.1 A
Process Data Out 4	Motor torque	0.1 %
Process Data Out 5	Motor power	0.1 %
Process Data Out 6	Motor voltage	0.1 V
Process Data Out 7	DC-link voltage	1 V
Process Data Out 8	Last active fault code	

Prohibited Frequencies (M3.7)

In some systems it may be necessary to avoid certain frequencies due to mechanical resonance problems. By setting up prohibited frequencies, it is possible to skip these ranges.

Table 33: Prohibited Frequencies.

Code	Parameter	Min	Max	Unit	Default	ID	Description
P3.7.1	Prohibited frequency range 1 low limit	-1,00	320,00	Hz	0,00	509	0 = Not used
P3.7.2	Prohibited frequency range 1 high limit	0,00	320,00	Hz	0,00	510	0 = Not used
P3.7.3	Prohibited frequency range 2 low limit	0,00	320,00	Hz	0,00	511	0 = Not used
P3.7.4	Prohibited frequency range 2 high limit	0,00	320,00	Hz	0,00	512	0 = Not used
P3.7.5	Prohibited frequency range 3 low limit	0,00	320,00	Hz	0,00	513	0 = Not used
P3.7.6	Prohibited frequency range 3 high limit	0,00	320,00	Hz	0,00	514	0 = Not used
P3.7.7	Ramp time factor	0,1	10,0	Times	1,0	518	Multiplier of the currently selected ramp time between prohibited frequency limits.

Limit supervisions (M3.8)

Choose here:

1. One or two (P3.8.1 [→ 58]/P3.8.5 [→ 58]) signal values for supervision.
2. Whether the low or high limits are supervised (P3.8.2 [→ 58]/P3.8.6 [→ 58]).
3. The actual limit values (P3.8.3 [→ 58]/P3.8.7 [→ 58]).
4. The hysteresis for the set limit values (P3.8.4 [→ 58]/P3.8.8 [→ 58]).

Table 34: Limits supervision settings.

Code	Parameter	Min	Max	Unit	Default	ID	Description
P3.8.1	Supervision #1 item selection	0	7		0	1431	0 = Output frequency 1 = Frequency reference 2 = Motor current 3 = Motor torque 4 = Motor power 5 = DC-link voltage 6 = Analog input 1 7 = Analog input 2

Code	Parameter	Min	Max	Unit	Default	ID	Description
P3.8.2	Supervision #1 mode	0	2		0	1432	0 = Not used 1 = Low limit supervision (output active over limit) 2 = High limit supervision (output active under limit)
P3.8.3	Supervision #1 limit	-200.000	200.000	Varies	25.00	1433	Supervision limit for selected item. Unit appears automatically.
P3.8.4	Supervision #1 limit hysteresis	-200.000	200.000	Varies	5.00	1434	Supervision limit hysteresis for selected item. Unit is set automatically.
P3.8.5	Supervision #2 item selection	0	7		1	1435	See P3.8.1 [→ 58]
P3.8.6	Supervision #2 mode	0	2		0	1436	See P3.8.2 [→ 58]
P3.8.7	Supervision #2 limit	-200.000	200.000	Varies	40.00	1437	See P3.8.3 [→ 58]
P3.8.8	Supervision #2 limit hysteresis	-200.000	200.000	Varies	5.00	1438	See P3.8.4 [→ 58]

Protections (M3.9)

Parameters of Motor thermal protection (P3.9.6 to P3.9.10)

The motor thermal protection is to protect the motor from overheating. The drive is capable of supplying higher than nominal current to the motor. If the load requires this high current, there is a risk that the motor will thermally overload. This is the case especially at low frequencies. At low frequencies, the cooling effect of the motor is reduced as well as its capacity. If the motor is equipped with an external fan, the load reduction at low speeds is small.

The motor thermal protection is based on a calculated model and it uses the output current of the drive to determine the load on the motor.

The motor thermal protection can be adjusted with parameters. The thermal current IT specifies the load current above which the motor is overloaded. This current limit is a function of the output frequency.

The thermal stage of the motor can be monitored on the control keypad display. See Group 2: Monitor group [→ 31].



⚠ CAUTION

The calculated model does not protect the motor if the airflow to the motor is reduced by blocked air intake grill.

The model starts from zero if the control board is powered off.

Stall Protection Parameters (P3.9.11 to P3.9.14)

The motor stall protection protects the motor from short time overload situations such as one caused by a stalled shaft. The reaction time of the stall protection can be set shorter than that of motor thermal protection. The stall state is defined with two parameters, P3.9.12 [→ 59] (Stall current [→ 59]) and P3.9.14 [→ 59] (*Stall frequency limit*). If the current is higher than the set limit and the output frequency is lower than the set limit, the stall state is true. There is actually no real indication of the shaft rotation. Stall protection is a type of over-current protection.

Under-load protection parameters (P3.9.15 to P3.9.18)

The purpose of the motor under-load protection is to ensure that there is load on the motor when the drive is running. If the motor loses its load, there might be a problem in the process, e.g. a broken belt or a dry pump.

Motor under-load protection can be adjusted by setting the under-load curve with parameters P3.9.16 (Underload protection: Field weakening area load [→ 59]) and P3.9.17 (Underload protection: Zero frequency load [→ 59]), see the following Table. The under-load curve is a squared curve set between the zero frequency and the field weakening point. The protection is not active below 5Hz (the under-load time counter is stopped).

The torque values for setting the underload curve are set in percentage which refers to the nominal torque of the motor. The motor's name plate data, parameter motor nominal current and the drive's nominal current IL are used to find the scaling ratio for the internal torque value. If other than nominal motor is used with the drive, the accuracy of the torque calculation decreases.

Table 35: Protections Settings.

Code	Parameter	Min	Max	Unit	Default	ID	Description
P3.9.1	Response to Analog input low fault	0	4		0	700	0 = No action 1 = Alarm 2 = Alarm, set preset fault frequency (par. P3.3.19 [→ 46]) 3 = Fault (Stop according to stop mode) 4 = Fault (Stop by coasting)
P3.9.2	Response to external fault	0	3		2	701	0 = No action 1 = Alarm 2 = Fault (Stop according to stop mode) 3 = Fault (Stop by coasting)
P3.9.3	Response to input phase fault	0	1		0	730	0 = 3-phase support 1 = 1-phase support NOTE: If 1-phase supply is used, 1-phase support must be selected.
P3.9.4	Undervoltage fault	0	1		0	727	0 = Fault stored in history 1 = Fault not stored in history
P3.9.5	Response to output phase fault	0	3		2	702	0 = No action 1 = Alarm 2 = Fault (Stop according to stop mode) 3 = Fault (Stop by coasting)

Code	Parameter	Min	Max	Unit	Default	ID	Description
P3.9.6	Motor thermal protection	0	3		2	704	0 = No action 1 = Alarm 2 = Fault (Stop according to stop mode) 3 = Fault (Stop by coasting)
P3.9.7	Motor ambient temperature factor	-20.0	100.0	°C	40.0	705	Ambient temperature in °C
P3.9.8	Motor thermal zero speed cooling	5.0	150.0	%	60.0	706	Defines the cooling factor at zero speed in relation to the point where the motor is running at nominal speed without external cooling.
P3.9.9	Motor thermal time constant	1	200	min	Varies	707	The time constant is the time within which the calculated thermal stage has reached 63% of its final value.
P3.9.10	Motor thermal load	0	150	%	100	708	
P3.9.11	Motor stall fault	0	3		0	709	0 = No action 1 = Alarm 2 = Fault (Stop according to stop mode) 3 = Fault (Stop by coasting)
P3.9.12	Stall current	0.00	2*I _H	A	I _H	710	For a stall stage to occur, the current must have exceeded this limit.
P3.9.13	Stall time limit	1.00	120.00	s	15.00	711	This is the maximum time allowed for a stall stage.
P3.9.14	Stall frequency limit	1.00	P3.3.2 [→ 46]	Hz	25.00	712	For a stall state to occur, the output frequency must have remained below this limit for a certain time.
P3.9.15	Underload fault (broken belt/dry pump)	0	3		0	713	0 = No action 1 = Alarm 2 = Fault (Stop according to stop mode) 3 = Fault (Stop by coasting)
P3.9.16	Underload protection: Field weakening area load [→ 97]	10.0	150.0	%	50.0	714	This parameter gives the value for the minimum torque allowed when the output frequency is above the field weakening point.
P3.9.17	Underload protection: Zero frequency load	5.0	150.0	%	10.0	715	This parameter gives value for the minimum torque allowed with zero frequency. If you change the value of parameter P3.1.1.4 [→ 42] this parameter is automatically restored to the default value.

Code	Parameter	Min	Max	Unit	Default	ID	Description
P3.9.18	Underload protection: Time limit [→ 97]	2.00	600.00	s	20.00	716	This is the maximum time allowed for an underload state to exist.
P3.9.19	Response to Fieldbus communication fault	0	4		3	733	0 = No action 1 = Alarm 2 = Alarm, set preset fault frequency (par. P3.3.19 [→ 46]) 3 = Fault (Stop according to stop mode) 4 = Fault (Stop by coasting)
P3.9.20	Slot communication fault	0	3		2	734	0 = No action 1 = Alarm 2 = Fault (Stop according to stop mode) 3 = Fault (Stop by coasting)
M3.9.14	PT-100 fault					740	0 = No action 1 = Alarm 2 = Fault (Stop according to stop mode) 3 = Fault (Stop by coasting)
P3.9.21	Thermistor fault	0	3		0	732	0 = No action 1 = Alarm 2 = Fault (Stop according to stop mode) 3 = Fault (Stop by coasting) It is recommended to set this value to 2 if an option card is installed which has a thermistor present.
M3.9.15	Response to Soft fill timeout	0	3		2	748	0 = No action 1 = Alarm 2 = Fault (Stop according to stop mode) 3 = Fault (Stop by coasting)
P3.9.22	Response to PID1 supervision fault	0	3		2	749	0 = No action 1 = Alarm 2 = Fault (Stop according to stop mode) 3 = Fault (Stop by coasting)
P3.9.23	Response to PID2 supervision fault	0	3		2	757	0 = No action 1 = Alarm 2 = Fault (Stop according to stop mode) 3 = Fault (Stop by coasting)
P3.9.25	TempFault Signal	0	6		Not Used	739	Selection for which signals to use for alarm and fault triggering.
P3.9.26	TempAlarm Limit	-30.0	200.0		130.0	741	Temperature for triggering an alarm.

Code	Parameter	Min	Max	Unit	Default	ID	Description
P3.9.27	TempFault Limit	-30.0	200.0		155.0	742	Temperature for triggering a fault.
P3.9.28	TempFault Response	0	3		Fault	740	Fault response for Temperature Fault. 0 = No response 1 = Alarm 2 = Fault (Stop according to stop mode) 3 = Fault (Stop by coasting)

Automatic reset (M3.10)

Table 36: Autoreset Settings.

Code	Parameter	Min	Max	Unit	Default	ID	Description
P3.10.1	Automatic reset	0	1		0	731	0 = Disabled 1 = Enabled
P3.10.2	Restart function	0	1		1	719	The start mode for Automatic reset is selected with this parameter: 0 = Flying start 1 = According to par. P3.2.4 [→ 45]
P3.10.3	Wait time	0,10	10000,0	s	0,50	717	Wait time before the first reset is executed.
P3.10.4	Trial time	0,00	10000,0	s	60,00	718	When the trial time has elapsed, and the fault is still active, the drive will trip to fault.
P3.10.5	Number of trials	1	10		4	759	NOTE: Total number of trials (irrespective of fault type)
P3.10.6	Auto-reset: Under-voltage	0	1		1	720	Auto-reset permitted? 0 = No 1 = Yes
P3.10.7	Auto-reset: Over-voltage	0	1		1	721	Auto-reset permitted? 0 = No 1 = Yes
P3.10.8	Auto-reset: Over-current	0	1		1	722	Auto-reset permitted? 0 = No 1 = Yes
P3.10.9	Auto-reset: AI low	0	1		1	723	Auto-reset permitted? 0 = No 1 = Yes
P3.10.10	Auto-reset: Unit over-temperature	0	1		1	724	Auto-reset permitted? 0 = No 1 = Yes

Code	Parameter	Min	Max	Unit	Default	ID	Description
P3.10.11	Auto-reset: Motor overtemperature	0	1		1	725	Auto-reset permitted? 0 = No 1 = Yes
P3.10.12	Auto-reset: External fault	0	1		0	726	Auto-reset permitted? 0 = No 1 = Yes
P3.10.13	Auto-reset: Underload fault	0	1		0	738	Auto-reset permitted? 0 = No 1 = Yes

Timer functions (M3.11)

The time functions (Time Channels) in the Siemens BT300 give you the possibility to program functions to be controlled by the internal RTC (Real Time Clock). Practically every function that can be controlled by a digital input can also be controlled by a Time Channel. Instead of having an external PLC controlling a digital input you can program the "closed" and "opened" intervals of the input internally.



NOTE:

The full functions of this parameter group can only be realized if the battery has been installed and the Real Time Clock (RTC) settings have been properly made during the Startup Wizard (see page [→ 11]). **It is not recommended** to use these functions without a battery backup because the drive's time and date settings will be reset at every power down if no battery is installed for the RTC.

Time channels

The on/off logic for the *Time channels* is configured by assigning *Intervals* or/and *Timers* to them. One *Time channel* can be controlled by many *Intervals* or *Timers* by assigning as many of these as needed to the *Time channel*.

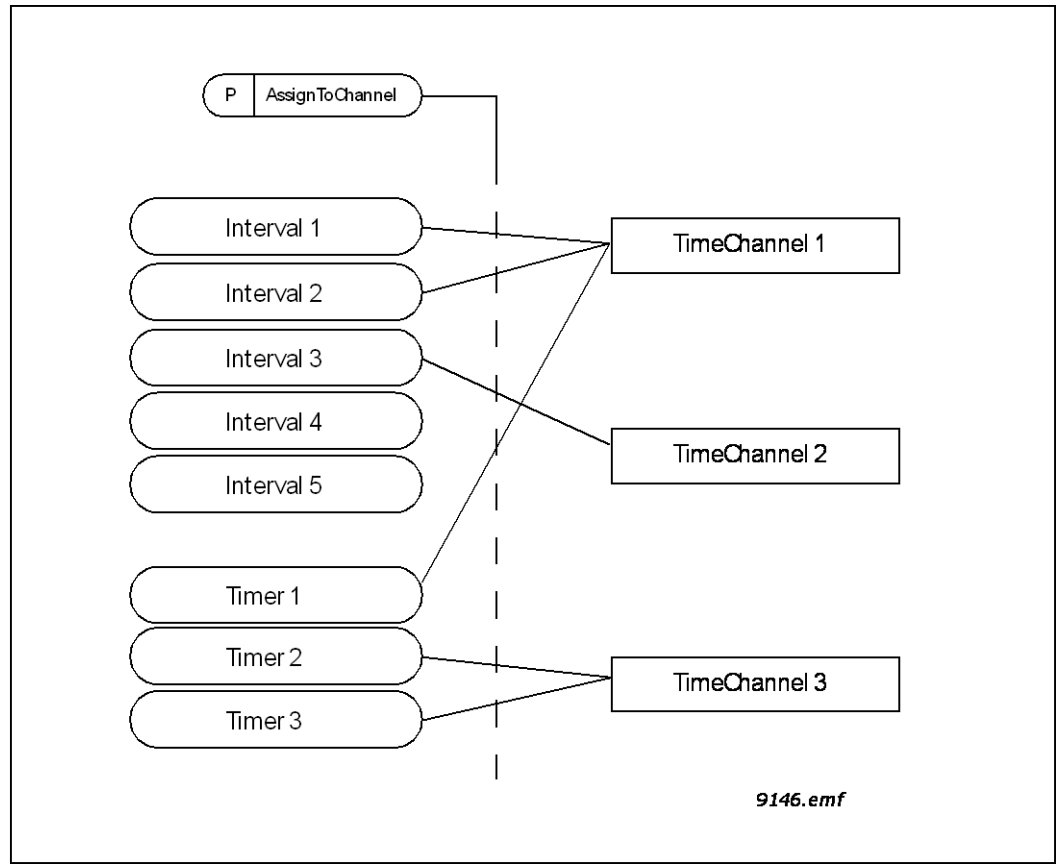

Figure 7: The intervals and timers can be assigned to time channels in a flexible way. Every interval and timer has its own parameter for assigning to a time channel.

Intervals

Every interval is given an "ON Time" and "OFF Time" with parameters. This is the daily time that the interval will be active during the days set with "From Day" and "To Day" parameters. E.g. the parameter setting below means that the interval is active from 7 am to 9 am every weekday (Monday to Friday). The Time Channel to which this Interval is assigned will be seen as a closed "virtual digital input" during that period.

ON Time: 07:00:00

OFF Time: 09:00:00

From Day: Monday

To Day: Friday

Timers

Timers can be used to set a Time Channel active during a certain time by command from a digital input (or a Time Channel).

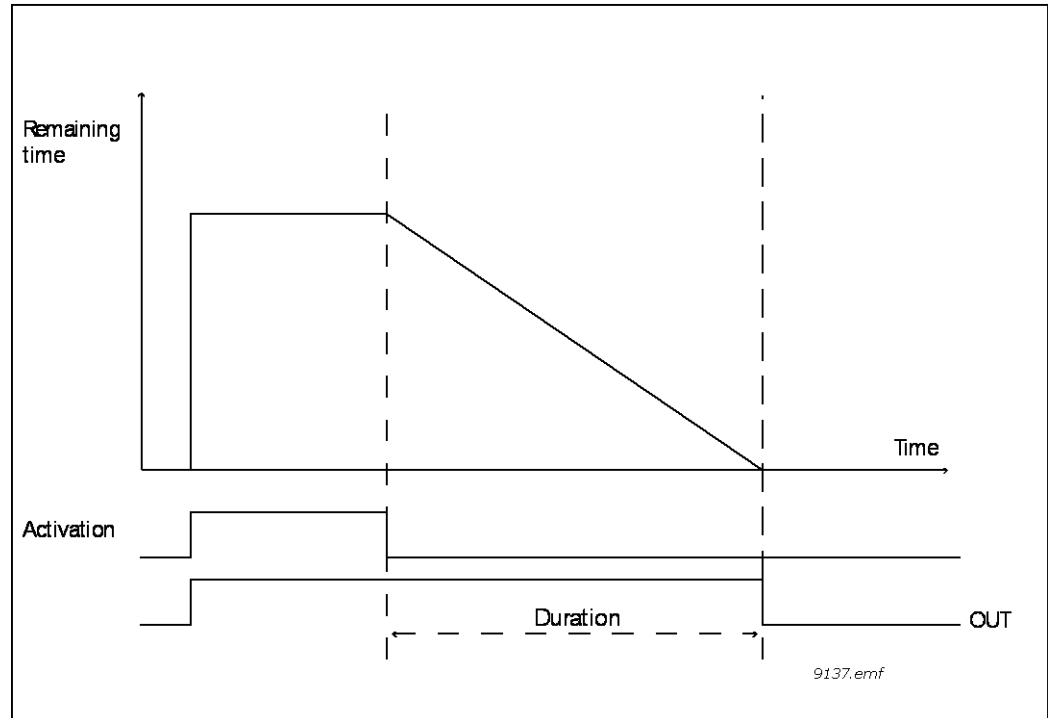

Figure 8: Activation signal comes from a digital input or "a virtual digital input" such as a Time channel. The Timer counts down from falling edge.

The below parameters will set the Timer active when Digital Input 1 on Slot A is closed and keep it active for 30 s after it is opened.

Duration: 30 s

Timer: DigIn SlotA.1

Tip: A duration of 0 seconds can be used for simply overriding a Time channel activated from a digital input without any off delay after the falling edge.

Example

Problem:

We have a variable frequency drive for air conditioning in a warehouse. It needs to run between 7am - 5pm on weekdays and 9am - 1pm on weekends. Additionally, we need to be able to manually force the drive to run outside working hours if there are people in the building and to leave it running for 30 min afterwards.

Solution:

We need to set up two intervals, one for weekdays and one for weekends. A Timer is also needed for activation outside the office hours. An example of configuration below.

Interval 1:

P3.11.1.1 [→ 64]: *ON Time:* 07:00:00

P3.11.1.2 [→ 64]: *OFF Time:* 17:00:00

P3.11.1.3 [→ 64]: *From Day:* '1' (=Monday)

P3.11.1.4 [→ 64]: *To Day:* '5' (=Friday)

P3.11.1.5 [→ 64]: *Assign to channel:* Time channel 1

*Interval 2:*P3.11.2.1 [→ 64]: *ON Time:* 09:00:00P3.11.2.2 [→ 64]: *OFF Time:* 13:00:00P3.11.2.3 [→ 64]: *From Day:* SaturdayP3.11.2.4 [→ 64]: *To Day:* SundayP3.11.2.5 [→ 64]: *AssignToChannel:* Time channel 1*Timer 1*

The manual bypassing can be handled by a digital input 1 on slot A (by a different switch or connection to lighting).

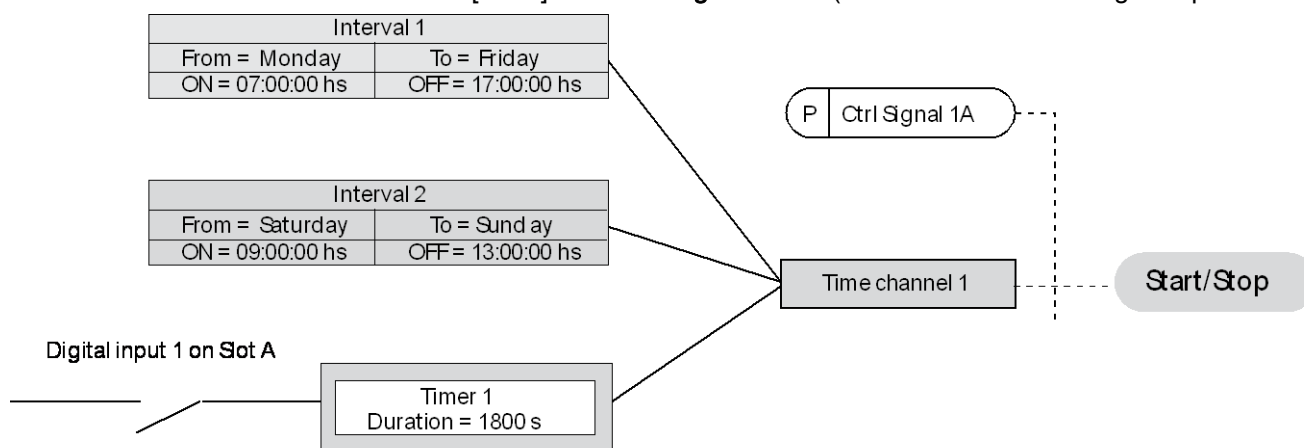
P3.11.6.1 [→ 64]: *Duration:* 1800s (30min)P3.11.6.2 [→ 64]: *Assign to channel:* Time channel 1P3.5.1.18 [→ 50]: *Timer 1: DigIn SlotA.1* (Parameter located in digital inputs menu.)

11092.eml

Figure 9: Final configuration where Time channel 1 is used as control signal for start command instead of a digital input.

Table 37: Timer functions.

Code	Parameter	Min	Max	Unit	Default	ID	Description
3.11.1 INTERVAL 1							
P3.11.1.1	ON time	00:00:00	23:59:59	hh:mm:ss	00:00:00	1464	ON time
P3.11.1.2	OFF time	00:00:00	23:59:59	hh:mm:ss	00:00:00	1465	OFF time
P3.11.1.3	From day	0	6		0	1466	ON day of week 0 = Sunday 1 = Monday 2 = Tuesday 3 = Wednesday 4 = Thursday 5 = Friday 6 = Saturday
P3.11.1.4	To day	0	6		0	1467	See above

Code	Parameter	Min	Max	Unit	Default	ID	Description
P3.11.1.5	Assign to channel	0	3		0	1468	Select affected time channel (1-3) 0 = Not used 1 = Time channel 1 2 = Time channel 2 3 = Time channel 3
3.11.2 INTERVAL 2							
P3.11.2.1	ON time	00:00:00	23:59:59	hh:mm:ss	00:00:00	1469	See Interval 1
P3.11.2.2	OFF time	00:00:00	23:59:59	hh:mm:ss	00:00:00	1470	See Interval 1
P3.11.2.3	From day	0	6		0	1471	See Interval 1
P3.11.2.4	To day	0	6		0	1472	See Interval 1
P3.11.2.5	Assign to channel	0	3		0	1473	See Interval 1
3.11.3 INTERVAL 3							
P3.11.3.1	ON time	00:00:00	23:59:59	hh:mm:ss	00:00:00	1474	See Interval 1
P3.11.3.2	OFF time	00:00:00	23:59:59	hh:mm:ss	00:00:00	1475	See Interval 1
P3.11.3.3	From day	0	6		0	1476	See Interval 1
P3.11.3.4	To day	0	6		0	1477	See Interval 1
P3.11.3.5	Assign to channel	0	3		0	1478	See Interval 1
3.11.4 INTERVAL 4							
P3.11.4.1	ON time	00:00:00	23:59:59	hh:mm:ss	00:00:00	1479	See Interval 1
P3.11.4.2	OFF time	00:00:00	23:59:59	hh:mm:ss	00:00:00	1480	See Interval 1
P3.11.4.3	From day	0	6		0	1481	See Interval 1
P3.11.4.4	To day	0	6		0	1482	See Interval 1
P3.11.4.5	Assign to channel	0	3		0	1483	See Interval 1
3.11.5 INTERVAL 5							
P3.11.5.1	ON time	00:00:00	23:59:59	hh:mm:ss	00:00:00	1484	See Interval 1
P3.11.5.2	OFF time	00:00:00	23:59:59	hh:mm:ss	00:00:00	1485	See Interval 1
P3.11.5.3	From day	0	6		0	1486	See Interval 1
P3.11.5.4	To day	0	6		0	1487	See Interval 1
P3.11.5.5	Assign to channel	0	3		0	1488	See Interval 1

Code	Parameter	Min	Max	Unit	Default	ID	Description
3.11.6 TIMER 1							
P3.11.6.1	Duration	0	72000	s	0	1489	The time the timer will run when activated. (Activated by DI)
P3.11.6.2	Assign to channel	0	3		0	1490	Select affected time channel (1-3) 0 = Not used 1 = Time channel 1 2 = Time channel 2 3 = Time channel 3
3.11.7 TIMER 2							
P3.11.7.1	Duration	0	72000	s	0	1491	See Timer 1
P3.11.7.2	Assign to channel	0	3		0	1492	See Timer 1
3.11.8 TIMER 3							
P3.11.8.1	Duration	0	72000	s	0	1493	See Timer 1
P3.11.8.2	Assign to channel	0	3		0	1494	See Timer 1

PID-controller 1 (M3.12)

Basic settings

Table 38: PID Basic Settings.

Code	Parameter	Min	Max	Unit	Default	ID	Description
P3.12.1.1	Gain	0.00	1000.00	%	100.00	118	If the value of the parameter is set to 100% a change of 10% in the error value causes the controller output to change by 10%.
P3.12.1.2	PID integration time	0.00	600.00	s	1.00	119	If this parameter is set to 1,00 second a change of 10% in the error value causes the controller output to change by 10.00%/s.
P3.12.1.3	PID derivation time	0.00	100.00	s	0.00	132	If this parameter is set to 1,00 second a change of 10% in the error value during 1.00 s causes the controller output to change by 10.00%.
P3.12.1.4	Process unit selection	1	38		1	1036	Select unit for actual value.

Code	Parameter	Min	Max	Unit	Default	ID	Description
P3.12.1.5	Process unit min	Varies	Varies	Varies	0	1033	The setpoint and feedback values are internally handled as percent, but can be scaled to process units on the panel. Process Unit selection selects unit. Process Unit Min and Max are the process values corresponding to 0% and 100% respectively (scaled linearly in between). Process Unit Decimals is for choosing how many decimals to show.
P3.12.1.6	Process unit max	Varies	Varies	Varies	100	1034	The setpoint and feedback values are internally handled as percent, but can be scaled to process units on the panel. Process Unit selection selects unit. Process Unit Min and Max are the process values corresponding to 0% and 100% respectively (scaled linearly in between). Process Unit Decimals is for choosing how many decimals to show.
P3.12.1.7	Process unit decimals	0	4		2	1035	Number of decimals for process unit value
P3.12.1.8	Error inversion	0	1		0	340	0 = Normal (Feedback < Setpoint -> Increase PID output) 1 = Inverted (Feedback < Setpoint -> Decrease PID output)
P3.12.1.9	Dead band hysteresis	Varies	Varies	Varies	0	1056	Dead band area around the setpoint in process units. The PID output is locked if the feedback stays within the dead band area for a predefined time.
P3.12.1.10	Dead band delay	0.00	320.00	s	0.00	1057	If the feedback stays within the dead band area for a predefined time, the output is locked.

Setpoints

Table 39: PID Setpoints.

Code	Parameter	Min	Max	Unit	Default	ID	Description
P3.12.2.1	Keypad setpoint 1	Varies	Varies	Varies	0	167	
P3.12.2.2	Keypad setpoint 2	Varies	Varies	Varies	0	168	
P3.12.2.3	Setpoint ramp time	0.00	300.0	s	0.00	1068	Defines the rising and falling ramp times for setpoint changes. (Time to change from minimum to maximum)
P3.12.2.4	Setpoint source 1 selection	0	16		1	332	0 = Not used 1 = Keypad setpoint 1 2 = Keypad setpoint 2 3 = AI1 4 = AI2 5 = AI3 6 = AI4 7 = AI5 8 = AI6 9 = ProcessDataIn1 10 = ProcessDataIn2 11 = ProcessDataIn3 12 = ProcessDataIn4 13 = ProcessDataIn5 14 = ProcessDataIn6 15 = ProcessDataIn7 16 = ProcessDataIn8 17 = Test Sequence AI's and ProcessDataIn are handled as percent (0.00-100.00%) and scaled according to Setpoint minimum and maximum. NOTE: ProcessDataIn use two decimals.
P3.12.2.5	Setpoint 1 minimum	-200.00	200.00	%	0.00	1069	Minimum value at analog signal minimum.
P3.12.2.6	Setpoint 1 maximum	-200.00	200.00	%	100.00	1070	Maximum value at analog signal maximum.
P3.12.2.7	Sleep frequency [→ 97]limit 1	0.00	320.00	Hz	0.00	1016	Drive goes to sleep mode when the output frequency stays below this limit for a time greater than that defined by parameter Sleep delay.
P3.12.2.8	Sleep delay 1	0	3000	s	0	1017	The minimum amount of time the frequency has to remain below the Sleep level before the drive is stopped.
P3.12.2.9	Wake-up level 1			Varies	0.0000	1018	Defines the level for the PID feedback value wake-up supervision. Uses selected

Code	Parameter	Min	Max	Unit	Default	ID	Description
							process units.
P3.12.2.10	Setpoint 1 boost	-2.0	2.0	x	1.0	1071	The setpoint can be boosted with a digital input.
P3.12.2.11	Setpoint source 2 selection	0	16		2	431	See par. P3.12.2.4 [→ 71]
P3.12.2.12	Setpoint 2 minimum	-200.00	200.00	%	0.00	1073	Minimum value at analog signal minimum.
P3.12.2.13	Setpoint 2 maximum	-200.00	200.00	%	100.00	1074	Maximum value at analog signal maximum.
P3.12.2.14	Sleep frequency limit 2	0.00	320.00	Hz	0.00	1075	See P3.12.2.7 [→ 71].
P3.12.2.15	Sleep delay 2	0	3000	s	0	1076	See P3.12.2.8 [→ 71].
P3.12.2.16	Wake-up level 2			Varies	0.0000	1077	See P3.12.2.9 [→ 71].
P3.12.2.17	Setpoint 2 boost	-2.0	2.0	Varies	1.0	1078	See P3.12.2.10 [→ 71].

Feedback

Table 40: PID Feedback.

Code	Parameter	Min	Max	Unit	Default	ID	Description
P3.12.3.1	Feedback function	1	9		1	333	1 = Only Source1 in use 2 = SQRT(Source1);(Flow= Constant x SQRT(Pressure)) 3 = SQRT(Source1- Source 2) 4 = SQRT(Source 1) + SQRT (Source 2) 5 = Source 1 + Source 2 6 = Source 1 - Source 2 7 = MIN (Source 1, Source 2) 8 = MAX (Source 1, Source 2) 9 = MEAN (Source 1, Source 2)
P3.12.3.2	Feedback function gain	-1000.0	1000.0	%	100.0	1058	Used e.g. with selection 2 in <i>Feedback function</i>
P3.12.3.3	Feedback 1 source selection	0	14		2	334	0 = Not used 1 = AI1 2 = AI2 3 = AI3 4 = AI4 5 = AI5 6 = AI6 7 = ProcessDataIn1 8 = ProcessDataIn2 9 = ProcessDataIn3 10 = ProcessDataIn4 11 = ProcessDataIn5

Code	Parameter	Min	Max	Unit	Default	ID	Description
							12 = ProcessDataIn6 13 = ProcessDataIn7 14 = ProcessDataIn8 AI's and ProcessDataIn are handled as % (0.00-100.00%) and scaled according to Feedback min and max. NOTE: ProcessDataIn use two decimals.
P3.12.3.4	Feedback 1 minimum	-200.00	200.00	%	0.00	336	Minimum value at analog signal minimum.
P3.12.3.5	Feedback 1 maximum	-200.00	200.00	%	100.00	337	Maximum value at analog signal maximum.
P3.12.3.6	Feedback 2 source selection	0	14		0	335	See P3.12.3.3 [→ 72]
P3.12.3.7	Feedback 2 minimum	-200.00	200.00	%	0.00	338	Minimum value at analog signal minimum.
P3.12.3.8	Feedback 2 maximum	-200.00	200.00	%	100.00	339	Maximum value at analog signal maximum.

Feedforward

Feedforward usually needs accurate process models, but in some simple cases a gain + offset type of feedforward is enough. The feedforward part does not use any feedback measurements of the actual controlled process value (water level in the example on page [→ 115]). Siemens feedforward control uses other measurements which are indirectly affecting the controlled process value.

Table 41: Feedforward.

Code	Parameter	Min	Max	Unit	Default	ID	Description
P3.12.4.1	F [→ 97]eedforward function	1	9		1	1059	See P3.12.3.1 [→ 72].
P3.12.4.2	Feedforward function gain	-1000	1000	%	100.0	1060	See P3.12.3.2 [→ 72].
P3.12.4.3	Feedforward 1 source selection	0	14		0	1061	See P3.12.3.3 [→ 72].
P3.12.4.4	Feedforward 1 minimum	-200.00	200.00	%	0.00	1062	See P3.12.3.4 [→ 72].
P3.12.4.5	Feedforward 1 maximum	-200.00	200.00	%	100.00	1063	See P3.12.3.5 [→ 72].
P3.12.4.6	Feedforward 2 source selection	0	14		0	1064	See P3.12.3.6 [→ 72].

Code	Parameter	Min	Max	Unit	Default	ID	Description
P3.12.4.7	Feedforward 2 min	-200.00	200.00	%	0.00	1065	See P3.12.3.7 [→ 72].
P3.12.4.8	Feedforward 2 max	-200.00	200.00	%	100.00	1066	See P3.12.3.8 [→ 72].

Soft fill

Code	Parameter	Min	Max	Unit	Default	ID	Description
P3.12.5.1	Enable soft fill	0	1		0	1094	0 = Disabled 1 = Enabled
P3.12.5.2	Soft fill frequency	0.00	50.00	Hz	20.00	1055	The drive accelerates to this frequency before starting to control.
P3.12.5.3	Soft fill level	Varies	Varies	Varies	0.0000	1095	The drive runs at the PID start frequency until the feedback reaches this value. At this point the controller starts to regulate (depending on acting mode).
P3.12.5.4	Soft fill timeout	0	30000	s	0	1096	If the desired value is not reached within this time a fault or alarm is created. 0 = No timeout

Process Supervision

Process supervision is used to control that the actual value stays within predefined limits. With this function you can e.g. detect a major pipe burst and stop unnecessary flooding. See more in the Process supervision [→ 79] section of *Chapter 5*.

Table 42: Process Supervision.

Code	Parameter	Min	Max	Unit	Default	ID	Description
P3.12.5.1	Enable process supervision	0	1		0	735	0 = Disabled 1 = Enabled
P3.12.5.2	Upper limit	Varies	Varies	Varies	Varies	736	Upper actual/process value supervision.
P3.12.5.3	Lower limit	Varies	Varies	Varies	Varies	758	Lower actual/process value supervision.
P3.12.5.4	Delay	0	30000	s	0	737	If the desired value is not reached within this time a fault or alarm is created.

Pressure Loss Compensation

Table 43: Pressure Loss Compensation.

Code	Parameter	Min	Max	Unit	Default	ID	Description
P3.12.6.1	E [→ 97]nable setpoint 1	0	1		0	1189	Enables pressure loss compensation for setpoint 1. 0 = Disabled 1 = Enabled
P3.12.6.2	Setpoint 1 max compensation	Varies	Varies	Varies	Varies	1190	Value added proportionally to the frequency. Setpoint compensation = $\text{Max compensation} \cdot (\text{FreqOut} - \text{MinFreq}) / (\text{MaxFreq} - \text{MinFreq})$
P3.12.6.3	Enable setpoint 2	0	1		0	1191	See P3.12.6.1 [→ 75].
P3.12.6.4	Setpoint 2 max compensation	Varies	Varies	Varies	Varies	1192	See P3.12.6.2 [→ 75].

PID-controller 2 (M3.13)

Basic settings

For more detailed information, see PID-controller 1 (M3.12) [→ 69].

Table 44: PID-2 Basic Settings.

Code	Parameter	Min	Max	Unit	Default	ID	Description
P3.13.1.1	Enable PID	0	1		0	1630	0 = Disabled 1 = Enabled
P3.13.1.2	Output in Stop	0.0	100.0	%	0.0	1100	The output value of the PID controller in % of its maximum output value while it is stopped from digital input
P3.13.1.3	PID gain	0.00	1000.00	%	100.00	1631	This parameter defines the gain of the PID controller. If the value of the parameter is set to 100% a change of 10% in the error value causes the controller output to change by 10%.
P3.13.1.4	PID integration time	0.00	600.00	s	1.00	1632	This parameter defines the derivation time of the PID controller. If it is set to 1,00 second a change of 10% in the error value during 1.00 s causes the controller output to change by 10.00%. If the parameter value is set to 0s the PID controller will operate as PI controller.

Code	Parameter	Min	Max	Unit	Default	ID	Description
P3.13.1.5	PID derivation time	0.00	100.00	s	0.00	1633	This parameter defines the derivation time of the PID controller. If it is set to 1,00 second a change of 10% in the error value during 1.00 s causes the controller output to change by 10.00%. If the parameter value is set to 0s the PID controller will operate as PI controller.
P3.13.1.6	Process unit selection	1	38		1	1635	The setpoint and feedback values are internally handled as percent, but can be scaled to process units on the panel. Process Unit selection selects unit. Process Unit Min and Max are the process values corresponding to 0% and 100% respectively (scaled linearly in between). Process Unit Decimals is for choosing how many decimals to show.
P3.13.1.7	Process unit min	Varies	Varies	Varies	0	1664	The setpoint and feedback values are internally handled as percent, but can be scaled to process units on the panel. Process Unit selection selects unit. Process Unit Min and Max are the process values corresponding to 0% and 100% respectively (scaled linearly in between). Process Unit Decimals is for choosing how many decimals to show.
P3.13.1.8	Process unit max	Varies	Varies	Varies	100	1665	The setpoint and feedback values are internally handled as percent, but can be scaled to process units on the panel. Process Unit selection selects unit. Process Unit Min and Max are the process values corresponding to 0% and 100% respectively (scaled linearly in between). Process Unit Decimals is for choosing how many decimals to show.
P3.13.1.9	Process unit decimals	0	4		2	1666	How many decimals to be shown with the process units. Internally accuracy is always 4 decimals.

Code	Parameter	Min	Max	Unit	Default	ID	Description
P3.13.1.10	Error inversion	0	1		0	1636	Dead band around the setpoint. When we are within this area the PID controller output will be locked. The size of the Dead Band area around the setpoint is set in process units. I.e. 2 bar will give us a dead band of +- 2bar around the setpoint. We can also set a delay.
P3.13.1.11	Dead band hysteresis	Varies	Varies	Varies	0.0	1637	Dead band around the setpoint. When we are within this area the PID controller output will be locked. The size of the Dead Band area around the setpoint is set in process units. I.e. 2 bar will give us a dead band of +- 2bar around the setpoint. We can also set a delay
P3.13.1.12	Dead band delay	0.00	320.00	s	0.00	1638	Dead band around the setpoint. When we are within this area the PID controller output will be locked. The size of the Dead Band area around the setpoint is set in process units. I.e. 2 bar will give us a dead band of +- 2bar around the setpoint. We can also set a delay

Setpoints

Table 45: PID-2 Setpoints.

Code	Parameter	Min	Max	Unit	Default	ID	Description
P3.13.2.1	Keypad setpoint 1	0.00	100.00	Varies	0.00	1640	Setpoint in process unit that can be selected as setpoint source (parameters).
P3.13.2.2	Keypad setpoint 2	0.00	100.00	Varies	0.00	1641	Setpoint in process unit that can be selected as setpoint source (parameters).
P3.13.2.3	Setpoint ramp time	0.00	300.00	s	0.00	1642	Sometimes we don't want to make fast step changes in the setpoint because it might upset the process. Then we can set a ramping time for the setpoint. The time set with this parameter is the time it takes for the setpoint to change from 0% to 100%. NOTICE! When starting the drive the setpoint will always ramp from the feedback value to the setpoint.

Code	Parameter	Min	Max	Unit	Default	ID	Description
P3.13.2.4	Setpoint source 1 selection	0	16		1	1643	Select from where we should take the signal for this setpoint. Notice! ProcessDataIn uses two decimals as format.
P3.13.2.5	Setpoint 1 minimum	-200.00	200.00	%	0.00	1644	Minimum value at analog signal minimum.
P3.13.2.6	Setpoint 1 maximum	-200.00	200.00	%	100.00	1645	Maximum value at analog signal maximum.
P3.13.2.7	Setpoint source 2 selection	0	16		0	1646	See P3.13.2.4 [→ 77].
P3.13.2.8	Setpoint 2 minimum	-200.00	200.00	%	0.00	1647	Minimum value at analog signal minimum.
P3.13.2.9	Setpoint 2 maximum	-200.00	200.00	%	100.00	1648	Maximum value at analog signal maximum.

Feedback

For more detailed information, see PID-controller 1 (M3.12) [→ 69].

Table 46: PID-2 Feedback.

Code	Parameter	Min	Max	Unit	Default	ID	Description
P3.13.3.1	Feedback function	1	9		1	1650	Choose a single signal used as feedback or make calculations based on one or two signals.
P3.13.3.2	Feedback function gain	-1000.0	1000.0	%	100.0	1651	Feedback Gain is added after the feedback function (parameter) before fed straight to the PID.
P3.13.3.3	Feedback 1 source selection	0	14		1	1652	Select from where we should take the signal for this feedback. Notice! ProcessDataIn uses two decimals as format.
P3.13.3.4	Feedback 1 minimum	-200.00	200.00	%	0.00	1653	Minimum value at analog signal minimum.
P3.13.3.5	Feedback 1 maximum	-200.00	200.00	%	100.00	1654	Maximum value at analog signal maximum.
P3.13.3.6	Feedback 2 source selection	0	14		2	1655	Select from where we should take the signal for this feedback. Notice! ProcessDataIn uses two decimals as format.
P3.13.3.7	Feedback 2 minimum	-200.00	200.00	%	0.00	1656	Minimum value at analog signal minimum.

Code	Parameter	Min	Max	Unit	Default	ID	Description
P3.13.3.8	Feedback 2 maximum	-200.00	200.00	%	100.00	1657	Maximum value at analog signal maximum.

Process supervision

For more detailed information, see PID-controller 1 (M3.12) [→ 69].

Table 47: PID-2 Process Supervision.

Code	Parameter	Min	Max	Unit	Default	ID	Description
P3.13.4.1	Enable supervision	0	1		0	1659	0 = Disabled 1 = Enabled
P3.13.4.2	Upper limit	Varies	Varies	Varies	Varies	1660	Process supervision is used to supervise that the actual value stays within some predefined limits. With this function we can e.g. detect a major pipe burst and stop unnecessary flooding. An upper and lower limit for the supervision range can be set, including a delay when triggering faults.
P3.13.4.3	Lower limit	Varies	Varies	Varies	Varies	1661	Process supervision is used to supervise that the actual value stays within some predefined limits. With this function we can e.g. detect a major pipe burst and stop unnecessary flooding. An upper and lower limit for the supervision range can be set, including a delay when triggering faults.
P3.13.4.4	Delay	0	30000	s	0	1662	If the desired value is not reached within this time a fault or alarm is activated.

Multi-pump (M3.14)

The *Multi-pump* functionality allows you to control **up to 4 motors** (pumps, fans) with PID controller 1. The drive is connected to one motor which is the "regulating" motor connecting and disconnecting the other motors to/from the mains by means of contactors controlled with relays when needed in order to maintain the right setpoint. The *Auto-change* function controls the order/priority in which the motors are started in order to guarantee their equal wear. The controlling motor *can be included* in the Auto-change and interlocks logic, or it may be selected to always functions as Motor 1. Motors can be taken out of use momentarily, for example, for service, using the motor Interlock function [→ 119].

Table 48: Multi-pump parameters.

Code	Parameter	Min	Max	Unit	Default	ID	Description
P3.14.1	Number of motors	1	4		1	1001	Total number of motors (pumps/fans) used in multi-pump system
P3.14.2	Interlock function	0	1		1	1032	Enable/Disable use of interlocks. Interlocks are used to tell the system if a motor is connected or not. 0 = Disabled 1 = Enabled
P3.14.3	I [→ 97]nclude FC	0	1		1	1028	Include the variable frequency drive in the auto-change and interlocking system. 0 = Disabled 1 = Enabled
P3.14.4	A [→ 97]uto-change	0	1		0	1027	Disable/enable rotation of starting order and priority of motors. 0 = Disabled 1 = Enabled
P3.14.5	Auto-change interval	0.0	3000.0	h	48.0	1029	After the expiry of the time defined with this parameter, the auto-change function takes place if the capacity used lies below the level defined with parameters P3.14.6 [→ 80] and P3.14.7 [→ 80].
P3.14.6	Auto-change: Frequency limit	0.00	50.00	Hz	25.00	1031	These parameters define the level below which the capacity used must remain so that the auto-change can take place.
P3.14.7	Auto-change: Motor limit	0	4		1	1030	
P3.14.8	Bandwidth	0	100	%	10	1097	Percentage of the setpoint. E.g.: Setpoint = 5 bar, Bandwidth = 10%: As long as the feedback value stays within 4.5...5.5 bar motor disconnection or removal will not take place.

Code	Parameter	Min	Max	Unit	Default	ID	Description
P3.14.9	Bandwidth delay	0	3600	s	10	1098	With feedback outside the bandwidth, this time must pass before pumps are added or removed.

Fire mode (M3.16)

The drive ignores all commands from the keypad, fieldbuses and the PC tool and runs at preset frequency when activated. If activated, the alarm sign is shown on the keypad and **the warranty is void**. In order to enable the function, you need to set a password in the description field for parameter Fire Mode password [→ 81]. Please note the NC (normally closed) type of this input!



NOTE:

The warranty is void if this function is activated!

There is also a different password for test mode to be used for testing the Fire Mode without the warranty becoming void.

Table 49: Fire Mode Parameters.

Code	Parameter	Min	Max	Unit	Default	ID	Description
P3.16.1	Fire Mode password	0	9999		0	1599	1001 = Enabled 1234 = Test mode
P3.16.2	Fire Mode activation Open				DigIN Slot0.2	1596	Open = Fire Mode active Close = No action
P3.16.3	Fire Mode Active Close				DigIN Slot0.1	1597	Open = Inactive Close = Active
P3.16.4	Fire Mode frequency	8.00	P3.3.2 [→ 46]	Hz	0.00	1598	Frequency used when Fire Mode is activated.
P3.16.5	Fire Mode frequency source	0	8		0	1617	Selection of reference source when Fire Mode is active. This enables selection of e.g. AI1 or PID controller as reference source also while operating in Fire Mode. 0 = Fire Mode frequency 1 = Preset speeds 2 = Keypad 3 = Fieldbus 4 = AI1 5 = AI2 6 = AI1 + AI2 7 = PID1 8 = Motor potentiometer

Code	Parameter	Min	Max	Unit	Default	ID	Description
P3.16.6	Fire Mode reverse				DigIN Slot0.1	1618	Reverse command of rotation direction while running in Fire Mode. This function has no effect in normal operation. FALSE = Forward TRUE = Reverse
P3.16.7	Fire Mode status	0	3		0	1597	Monitoring value (see also Table [→ 32]) 0 = Disabled 1 = Enabled 2 = Activated (Enabled + DI Open) 3 = Test Mode
V3.16.8	Firemode counter	0	4294967 295			1679	Lets you know how many time fire mode has been activated. Fire mode cannot be reset.

Application settings (M3.17)

Table 50: Application settings.

Code	Parameter	Min	Max	Unit	Default	ID	Description
P3.17.1	Password	0	65000		0		
P3.17.2	KW/HP Select	KW	HP		KW	1198	
P3.17.3	°C/°F Select	°C	°F		°C	1197	
P3.17.4	Bypass	0	2		0	1809	0 = Disabled 1 = Conventional 2 = Electronic

Chapter 6 - Diagnostics (M4)

Under this menu, you can find Active faults [→ 83], Reset faults [→ 83], Fault history [→ 83], *Counters* and Software info [→ 85].

Active faults (M4.1)

Table 51:

Menu	Function	Note
Active faults	When a fault/faults display(s), the display with the name of the fault starts to blink. Press OK to return to the Diagnostics menu. The Active faults [→ 83] sub-menu shows the number of faults. Select the fault and press OK to see the fault-time data.	The fault remains active until it is cleared with the Reset button (press for 2 s) or with a reset signal from the I/O terminal or fieldbus or by choosing Reset faults [→ 83] (see below). The memory of active faults can store the maximum of 10 faults in the order of appearance.

Reset faults (M4.2)

Table 52:

Menu	Function	Note
Reset faults	In this menu you can reset faults. For detailed instructions, see Fault Displays [→ 125].	 CAUTION! Remove external Control signal before resetting the fault to prevent unintentional restart of the drive.

Fault history (M4.3)

Table 53:

Menu	Function	Note
Fault history	40 latest faults are stored in the Fault history.	Entering the Fault history and clicking OK on the selected fault shows the fault time data (details).
Application info	Application ID	Information (<i>Application ID</i> , <i>Version</i> and <i>Firmware interface</i>) about applications loaded into the variable frequency drive.
	Firmware interface	
Hardware info	Unit power	Unit power in hp
	Unit voltage	Nominal voltage of the unit

Menu	Function	Note
Statistics	Output current profile	
	Output frequency profile	
	Unit temperature profile	

Fault history

In menu M4.3, Fault history, you find the maximum number of 40 occurred faults. On each fault in the memory you will also find additional information. See the following Figure.

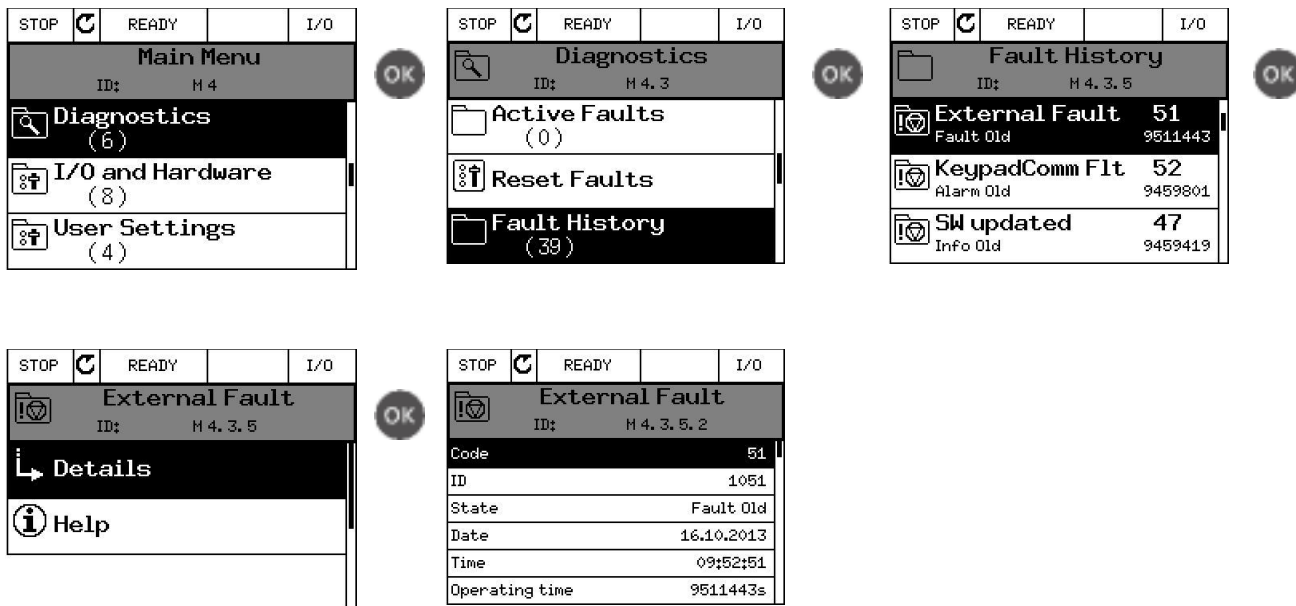

Total counters (M4.4)

Table 54:

Diagnostics menu, Total counters parameters.							
Code	Parameter	Min	Max	Unit	Default	ID	Description
V4.4.1	Energy counter			Varies		2291	Amount of energy taken from supply network. No reset.
V4.4.3	Operating time			y d hh:mm		2298	Control unit operating time
V4.4.7	Run time			y d hh:mm		2293	Motor running time
V4.4.11	Power on time			y d hh:mm			Amount of time the power unit has been powered so far. No reset.

Diagnostics menu, Total counters parameters.							
V4.4.15	Start command counter					2295	The number of times the power unit has been started.

Trip counters (M4.5)

Table 55:

Diagnostics menu, Trip counters parameters.							
Code	Parameter	Min	Max	Unit	Default	ID	Description
P4.5.1	Energy trip counter			Varies		2296	Resettable energy counter. NOTE: The highest energy unit shown on the standard keypad is <i>MW</i> . Should the counted energy exceed 999.9 MW, no unit is shown on the keypad.
P4.5.3	Operating time			y d hh:mm		2299	Resettable. See P4.5.1 [→ 85].

Software info (M4.6)

Table 56:

Diagnostics menu, Software info parameters.							
Code	Parameter	Min	Max	Unit	Default	ID	Description
V4.6.1	Software package					2524	
V4.6.4	System load	0	100	%		2300	Load on control unit CPU.
V4.6.5	Application name					2525	Name of application
V4.6.6	Application ID					837	
V4.6.7	Application version					838	

Chapter 7 - I/O and hardware (M5)

Various options-related settings are located in this menu.

Basic I/O (M5.1)

Monitor here the status of inputs and outputs.

Table 57: I/O and Hardware menu, Basic I/O parameters.

Code	Parameter	Min	Max	Unit	Default	ID	Description
V5.1.1	Digital input 1	0	1		0	2502	Status of digital input signal
V5.1.2	Digital input 2	0	1		0	2503	Status of digital input signal
V5.1.3	Digital input 3	0	1		0	2504	Status of digital input signal
V5.1.4	Digital input 4	0	1		0	2505	Status of digital input signal
V5.1.5	Digital input 5	0	1		0	2506	Status of digital input signal
V5.1.6	Digital input 6	0	1		0	2507	Status of digital input signal
V5.1.7	Analog input 1 mode	1	3		3	2508	Shows the selected (with jumper) mode for analog input signal 1 = 0...20 mA 3 = 0...10 V
V5.1.8	Analog input 1	0	100	%	0.00	2509	Status of analog input signal
V5.1.9	Analog input 2 mode	1	3		1	2010	Shows the selected (with jumper) mode for analog input signal 1 = 0...20 mA 3 = 0...10 V
V5.1.10	Analog input 2	0	100	%	0.00	2011	Status of analog input signal
V5.1.11	Analog output 1 mode	1	3		1	2012	Shows the selected (with jumper) mode for analog output signal 1 = 0...20 mA 3 = 0...10 V
V5.1.12	Analog output 1	0	100	%		2013	Status of analog output signal
V5.1.13	Relay Out 1	0	1		0	2014	Status of relay output signal
V5.1.14	Relay Out 2	0	1		0	2015	Status of relay output signal
V5.1.15	Relay Out 3	0	1		0	2016	Status of relay output signal

Option board slots

The parameters of this group depend on the option board installed. If no option board is placed in slots C, D, or E, no parameters are visible. See the Figure in the *Parameter Programming* section [→ 40] for the location of the slots.

When an option board is removed, the message `F39 Device removed` displays. For more information, see the Table in the *Fault Codes* section [→ 126].

Table 58: Option board-related parameters.

Menu	Function	Description
Slot C (M5.2)	Settings	Option board related settings.
	Monitoring	Monitor option board-related info.
Slot D (M5.3)	Settings	Option board related settings.
	Monitoring	Monitor option board-related info.
Slot E (M5.4)	Settings	Option board related settings.
	Monitoring	Monitor option board-related info.

Real time clock (M5.5)

Table 59: I/O and Hardware menu, Real time clock parameters.

Code	Parameter	Min	Max	Unit	Default	ID	Description
V5.5.1	Battery state	1	3		2	2205	Status of battery. 1 = Not installed 2 = Installed 3 = Change battery
V5.5.2	Time			hh:mm:ss		2201	Current time of day
V5.5.3	Date			dd.mm.		2202	Current date
V5.5.4	Year			yyyy		2203	Current year
V5.5.5	Daylight saving	1	4		1	2204	Daylight saving rule 1 = Off 2 = EU 3 = US 4 = Russia

Power unit settings, Cooling Fan control (M5.6)

The cooling fan operates in optimized or Always-On mode. In the optimized mode, fan speed is controlled according to the drive's internal logic that receives data from temperature measurements (if supported by the power unit) and the fan stops in 5 minutes when the drive is in Ready state. In Always-On mode, the fan runs in full speed, without stopping.

Table 60: Power unit settings, Cooling Fan control.

Code	Parameter	Min	Max	Unit	Default	ID	Description
V5.6.1.1	Fan control mode	0	1		1	2377	0 = Always On 1 = Optimized

Sine filter

Sine filter support restricts overmodulation depth and prevents thermal management functions from decreasing switching frequency.

Table 61: Power unit settings, Sine filter.

Code	Parameter	Min	Max	Unit	Default	ID	Description
V5.6.4.1	Sine filter	0	1		0	2527	0 = Disabled 1 = Enabled

Keypad (M5.7)

Table 62: I/O and Hardware menu, Keypad parameters.

Code	Parameter	Min	Max	Unit	Default	ID	Description
P5.7.1	Timeout time	0	60	min	0	804	Time after which the display returns to page defined with parameter P5.7.2. 0 = Not used
P5.7.2	Default page	0	4		0	2318	0 = None 1 = Enter menu index 2 = Main menu 3 = Control page 4 = Multi-monitor
P5.7.3	Menu index				0.0.0.0.0	2499	Set menu index for desired page and activate with parameter P.5.7.2 = 1.
P5.7.4	Contrast	30	70	%	50	830	Set contrast of the display (30...70%).
P5.7.5	Backlight time	0	60	min	5	818	Set the time until the backlight of the display turns off (0...60 min). If set to 0 s, backlight is always on.

Fieldbus (M5.8)

Parameters related to different fieldbus boards can also be found in the *I/O and Hardware* menu. These parameters are explained in more detail in the respective fieldbus manual.

Table 63: RS-485 (M5.8) Sub-menu.

Sub-menu level 2	Sub-menu level 3	ID	Sub-menu level 4
Common Settings (M5.8.1)	Protocol (P5.8.1.1)	2208	N2 BACnet MS/TP P1 Modbus RTU No Protocol (Default)
N2 (M5.8.3)	Parameters (M5.8.3.1)	2350	Device address (P5.8.3.1.1)
		2351	Comm. Timeout (P5.8.3.1.2)
	Monitoring (M5.8.3.2)	2399	FB Protocol Status (P5.8.3.2.1)
		2400	Comm Status (P5.8.3.2.2)
		2041	Invalid Data (P5.8.3.2.3)
		2402	Invalid Commands (P5.8.3.2.4)
		2403	Command NACK (P5.8.3.2.5)
		2404	Control Word (P5.8.3.2.6)
BACnet MS/TP (M5.8.3)	Parameters (M5.8.3.1)	2392	Baud Rate (P5.8.3.1.1)
		2330	Autobauding (P5.8.3.1.2)
		23331	MAC Address (P5.8.3.1.3)
		2332	Instance Number (P5.8.3.1.4)
		2333	Comm. Timeout (P5.8.3.1.5)
	Monitoring (M5.8.3.2)	2393	FB Protocol Status (P5.8.3.2.1)
		2394	Comm. Status (P5.8.3.2.2)
		2395	Actual Instance (P5.8.3.2.3)
		2396	Fault Code (P5.8.3.2.4)
		2397	Control Word (P5.8.3.2.5)
		2398	Status Word (P5.8.3.2.6)

Sub-menu level 2	Sub-menu level 3	ID	Sub-menu level 4
P1 (M5.8.3)	Parameters (M5.8.3.1)	2534	Slave Address (P5.8.3.1.1)
		2535	Baud Rate (P5.8.3.1.2)
		2536	Comm. Timeout (P5.8.3.1.3)
	Monitoring (M5.8.3.2)	2537	FB Protocol Status (P5.8.3.2.1)
Modbus RTU (M5.8.3)	Parameters (M5.8.3.1)	2320	Slave Address (P5.8.3.1.1)
		2378	Baud Rate (P5.8.3.1.2)
		2379	Parity Type (P5.8.3.1.3)
		2380	Stopbits (P5.8.3.1.4)
		2381	Comm. Timeout (P5.8.3.1.5)
		2374	Operate Mode (P5.8.3.1.6)
	Monitoring (M5.8.3.2)	2381	FB Protocol Status (P5.8.3.2.1)
		2382	Comm. Status (P5.8.3.2.2)
		2383	Illegal functions (P5.8.3.2.3)
		2384	Illegal data addr. (P5.8.3.2.4)
		2385	Illegal data values (P5.8.3.2.5)
		2385	Slave device busy (P5.8.3.2.6)
		2385	Memory parity error (P5.8.3.2.7)
		2388	Slave dev. Failure (P5.8.3.2.8)
		2389	Last fault response (P5.8.3.2.9)
		2390	Control Word (P5.8.3.2.10)
		2391	Status Word (P5.8.3.2.11)

Table 64: Ethernet (M5.9) Sub-menu.

Sub-menu level 2	Sub-menu level 3	ID	Sub-menu level 4
Common settings (M5.9.1)	IP address mode	2482	DCHP with AutoIP Fixed IP (P5.9.1.1)
	Fixed IP (M5.9.1.2)	2529	IP Address (P5.9.1.2.1)
		2530	Subnet Mask (P5.9.1.2.2)
		2531	Default Gateway (P5.9.1.2.3)
	IP address	2483	V5.9.1.3
	Subnet Mask	2484	V5.9.1.4
	Default Gateway	2485	V5.9.1.5
	MAC Address	2486	V5.9.1.6
Modbus TCP (M5.9.2)	Common Settings (M5.9.2.1)	2446	Connection limit (P5.9.2.1.1)
		2447	Slave address (P5.9.2.1.2)
		2448	Comm. Timeout (P5.9.2.1.3)
BACnet/IP (M5.9.3)	Settings (M5.9.3.1)	2406	Instance Number (P5.9.3.1.1)
		2407	Communication timeout (P5.9.3.1.2)
		2408	Protocol in use (P5.9.3.1.3)
		2409	BBMD IP (P5.9.3.1.4)
		2410	BBMD port (P5.9.3.1.5)
		2411	Time to live (P5.9.3.1.6)
	Monitoring (M5.9.3.2)	2412	FB Protocol Status (P5.9.3.2.1)
		2413	Comm. Timeout (P5.9.3.2.2)
		2414	Actual Instance (P5.9.3.2.3)
		2415	Control Word (P5.9.3.2.4)
		2416	Status Word (P5.9.3.2.5)

Chapter 8 - User Settings, Favorites, and User Level Menus

User settings (M6)

Table 65: User settings menu, General settings.

Code	Parameter	Min	Max	Unit	Default	ID	Description
P6.1	Language selections	Varies	Varies		Varies	802	Depends on language package.
P6.2	Application selection					801	
M6.5	Parameter backup	See the Parameter backup [→ 93]section.					
M6.6	Parameter compare						
P6.7	Drive name				Drive	2528	User specified drive name

Parameter backup

Table 66: User settings menu, Parameter backup parameters.

Code	Parameter	Min	Max	Unit	Default	ID	Description
	Save to set						
P6.5.1	Restore factory defaults					831	Restores default parameter values and initiates the Start-up Wizard
P6.5.2	Save to keypad	0	1		0		Save parameter values to keypad to e.g. copy them to another drive. 0 = No 1 = Yes
P6.5.3	Restore from keypad						Load parameter values from keypad to the drive.
B6.5.4	Save to Set 1						Store a customized parameter set (all parameters included in the application)
B6.5.5	Restore from Set 1						Load the customized parameter set to the drive
B6.5.6	Save to Set 2						Store a customized parameter set (all parameters included in the application)

Code	Parameter	Min	Max	Unit	Default	ID	Description
B6.5.7	Restore from Set 2						Load the customized parameter set to the drive

Favorites (M7)

Favorites are typically used to collect a set of parameters or monitoring signals from any of the keypad menus. You can add items or parameters to the Favorites folder, see Adding an item to Favorites [→ 26].

To remove an item or a parameter from the Favorites folder, do the following:

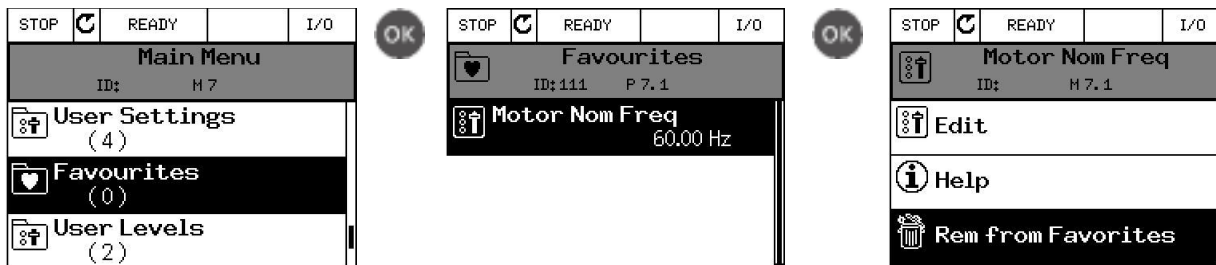

User levels

User level parameters are intended to restrict the visibility of parameters and to prevent unauthorized and inadvertent parameterization on the keypad.

Table 67: User level parameters.

Code	Parameter	Min	Max	Unit	Default	ID	Description
	Save to set						
P8.1	User level	0	1		0	1194	0 = Normal 1 = Monitoring In monitoring level only the Monitor, Favorites and User Levels menus are visible in the main menu.
P8.2	Access code	0	9		0	2362	If set to other value than 0 before switching to monitoring when e.g. user level <i>Normal</i> is active, the access code will be asked when trying to switch back to <i>Normal</i> . Can therefore be used to prevent unauthorized parameterization on the keypad.

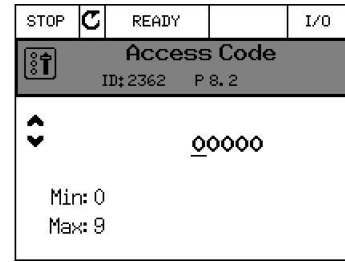
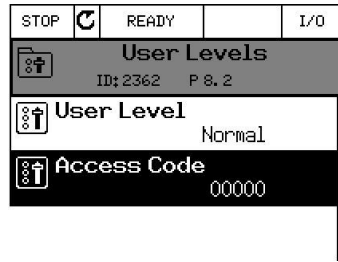
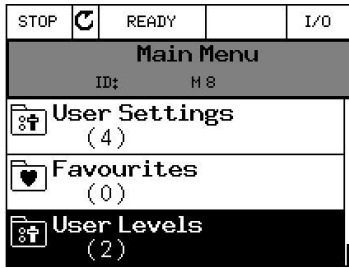

Chapter 9 - HVAC Application - Additional parameter information

Due to its simplicity of use, most parameters of the Siemens Application only require a basic description, which is given in the parameter tables in Chapter 5 - Parameters (M3) [→ 39].

In this chapter, you will find additional information on some of the more advanced application parameters. Should you not find the information you need, please contact Technical Support.

Group 3.1: Motor Settings

Motor current limit (P3.1.1.7)

This parameter determines the maximum motor current from the drive. The parameter value range differs from size to size.

When the current limit is active, the drive output frequency is decreased.



NOTE:

This is not an over-current trip limit.

U/f ratio selection (P3.1.2.9)

Table 68:

Selection number	Selection name	Description
0	Linear	The voltage of the motor changes linearly as a function of output frequency from zero frequency voltage (P3.1.2.4 [→ 43]) to the field weakening point (FWP) voltage at FWP frequency. This default setting should be used if there is no special need for another setting.
1	Squared	The voltage of the motor changes from zero point voltage (P3.1.2.4 [→ 43]) following a squared curve form from zero to the field weakening point. The motor runs under-magnetized below the field weakening point and produces less torque. Squared U/f ratio can be used in applications where torque demand is proportional to the square of the speed, e.g. in centrifugal fans and pumps.

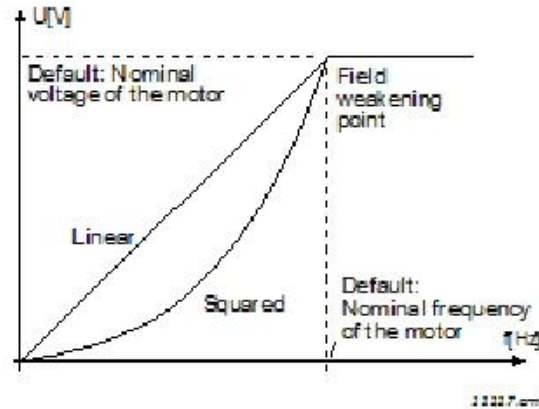

Figure 10: Linear and squared change of motor voltage.

Over-voltage controller (P3.1.2.15)

Under-voltage controller (P3.1.2.16)

These parameters allow the under-/overvoltage controllers to be switched out of operation. This may be useful, for example, if the mains supply voltage varies more than -15% to +10% and the application will not tolerate this over-/under-voltage. In this case, the regulator controls the output frequency taking the supply fluctuations into account.

Group 3.2: Start/Stop Setup

Stop function (P3.2.5)

Table 69:

Selection number	Selection name	Description
0	Coasting	The motor is allowed to stop on its own inertia. The control by the drive is discontinued and the drive current drops to zero as soon as the stop command is given.
1	Ramp	After the Stop command, the speed of the motor is decelerated according to the set deceleration parameters to zero speed.

I/O A start/stop logic (P3.2.6)

Values 0...4 offer possibilities to control the starting and stopping of the drive with a digital signal connected to digital inputs. CS = Control signal.

The selections including the text 'edge' shall be used to exclude the possibility of an unintentional start when, for example, power is connected, re-connected after a power failure, after a fault reset, after the drive is stopped by Run Enable (Run Enable = False) or when the control place is changed to I/O control. *The Start/Stop contact must be opened before the motor can be started.*

The used stop mode is *Coasting* in all examples.

Selection number	Selection name	Note
0	CS1: Forward CS2: Backward	The functions take place when the contacts are closed.

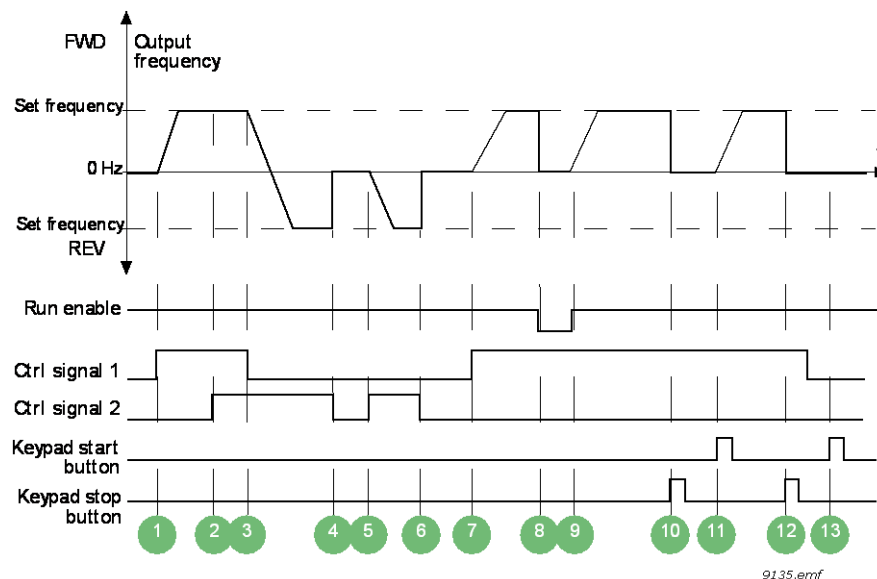

Figure 11: I/O A Start/Stop logic = 0.

Table 70: Legend

1	Control signal (CS) 1 activates causing the output frequency to rise. The motor runs forward.	8	Run enable signal is set to FALSE, which drops the frequency to 0. The run enable signal is configured with parameter P3.5.1.11.
2	CS2 activates which, however, has no effect on the output frequency because the first selected direction has the highest priority.	9	Run enable signal is set to TRUE, which causes the frequency to rise towards the set frequency because CS1 is still active.
3	CS1 is inactivated which causes the direction to start changing (FWD to REV) because CS2 is still active.	10	Keypad stop button is pressed and the frequency fed to the motor drops to 0. (This signal only works if P3.2.3 [→ 45] Keypad stop button [→ 45] = Yes)
4	CS2 inactivates and the frequency fed to the motor drops to 0.	11	The drive starts through pressing the Start button on the keypad.
5	CS2 activates again causing the motor to accelerate (REV) towards the set frequency.	12	The keypad stop button is pressed again to stop the drive.
6	CS2 inactivates and the frequency fed to the motor drops to 0.	13	The attempt to start the drive through pressing the Start button is not successful because CS1 is inactive.
7	CS1 activates and the motor accelerates (FWD) towards the set frequency		

Selection number	Selection name	Note
1	CS1: Forward (edge) CS2: Inverted stop	

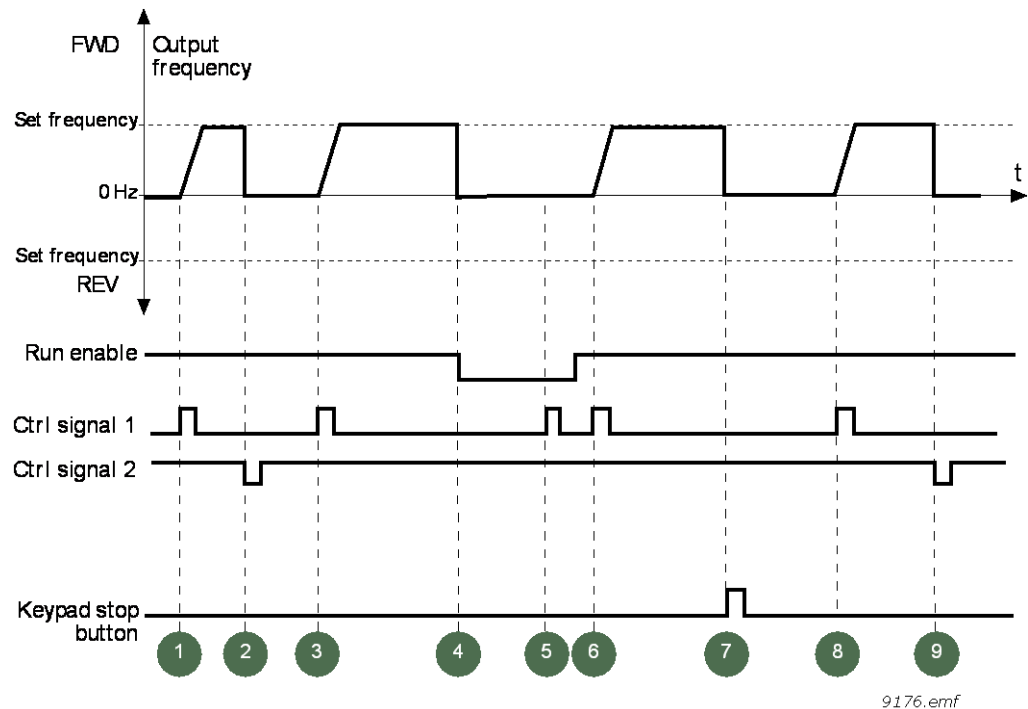
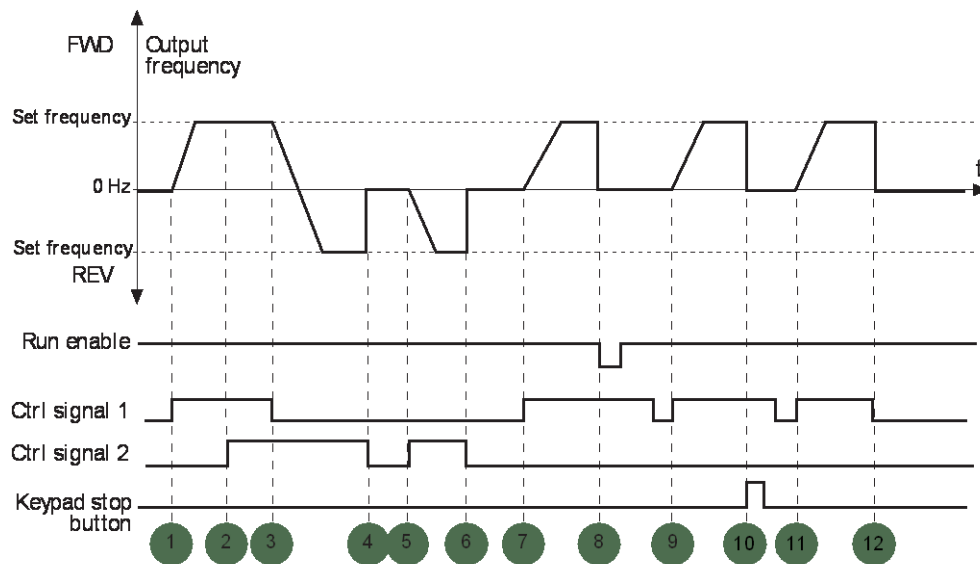

Figure 12: I/O A Start/Stop logic = 1.

Table 71: Legend

1	Control signal (CS) 1 activates causing the output frequency to rise. The motor runs forward.	6	CS1 activates and the motor accelerates (FWD) towards the set frequency because the Run enable signal has been set to TRUE.
2	CS2 inactivates causing the frequency to drop to 0.	7	Keypad stop button is pressed and the frequency fed to the motor drops to 0. (This signal only works if P3.2.3 [→ 45] Keypad stop button [→ 45] = Yes)
3	CS1 activates causing the output frequency to rise again. The motor runs forward.	8	CS1 activates causing the output frequency to rise again. The motor runs forward.
4	Run enable signal is set to FALSE, which drops the frequency to 0. The run enable signal is configured with parameter P3.5.1.10.	9	CS2 inactivates causing the frequency to drop to 0.
5	Start attempt with CS1 is not successful because Run enable signal is still FALSE.		

Selection number	Selection name	Note
2	CS1: Forward (edge) CS2: Backward (edge)	Used to exclude the possibility of an unintentional start. The Start/Stop contact must be opened before the motor can be restarted.



11093.emf

Figure 13: I/O A Start/Stop logic = 2.

Table 72: Legend

1	Control signal (CS) 1 activates causing the output frequency to rise. The motor runs forward.	7	CS1 activates and the motor accelerates (FWD) towards the set frequency
2	CS2 activates which, however, has no effect on the output frequency because the first selected direction has the highest priority.	8	Run enable signal is set to FALSE, which drops the frequency to 0. The run enable signal is configured with parameter P3.5.1.11.
3	CS1 is inactivated which causes the direction to start changing (FWD to REV) because CS2 is still active.	9	Run enable signal is set to TRUE, which, unlike if value 0 is selected for this parameter, has no effect because rising edge is required to start even if CS1 is active.
4	CS2 inactivates and the frequency fed to the motor drops to 0.	10	Keypad stop button is pressed and the frequency fed to the motor drops to 0. (This signal only works if P3.2.3 [→ 45] Keypad stop button [→ 45] = Yes)
5	CS2 activates again causing the motor to accelerate (REV) towards the set frequency.	11	CS1 is opened and closed again which causes the motor to start.
6	CS2 inactivates and the frequency fed to the motor drops to 0.	12	CS1 inactivates and the frequency fed to the motor drops to 0.

Selection number	Selection name	Note
3	CS1: Start CS2: Reverse	

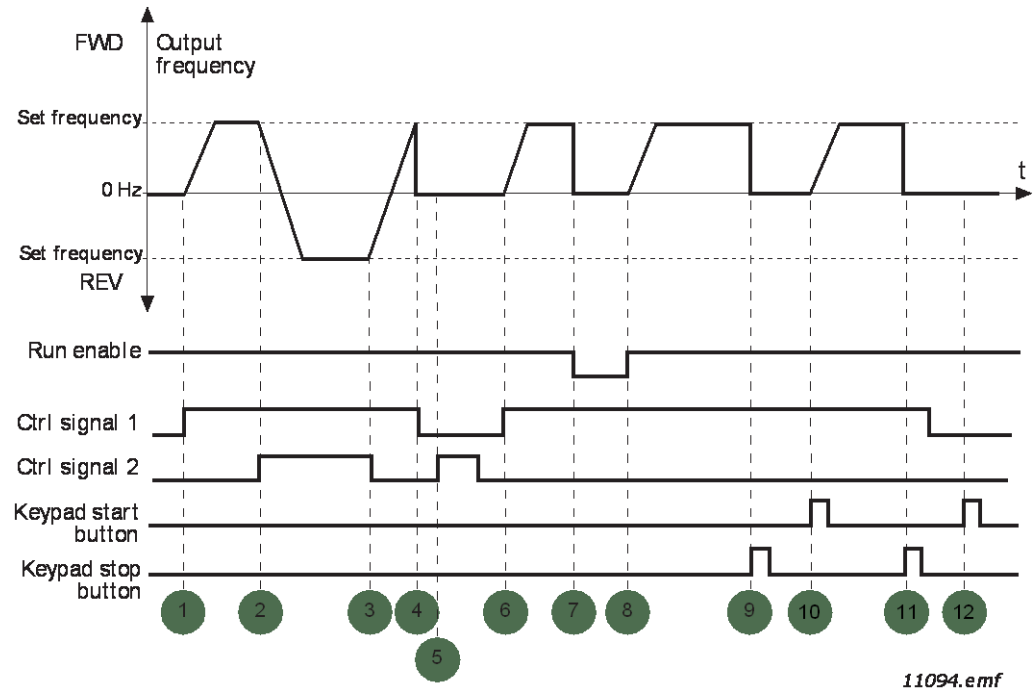
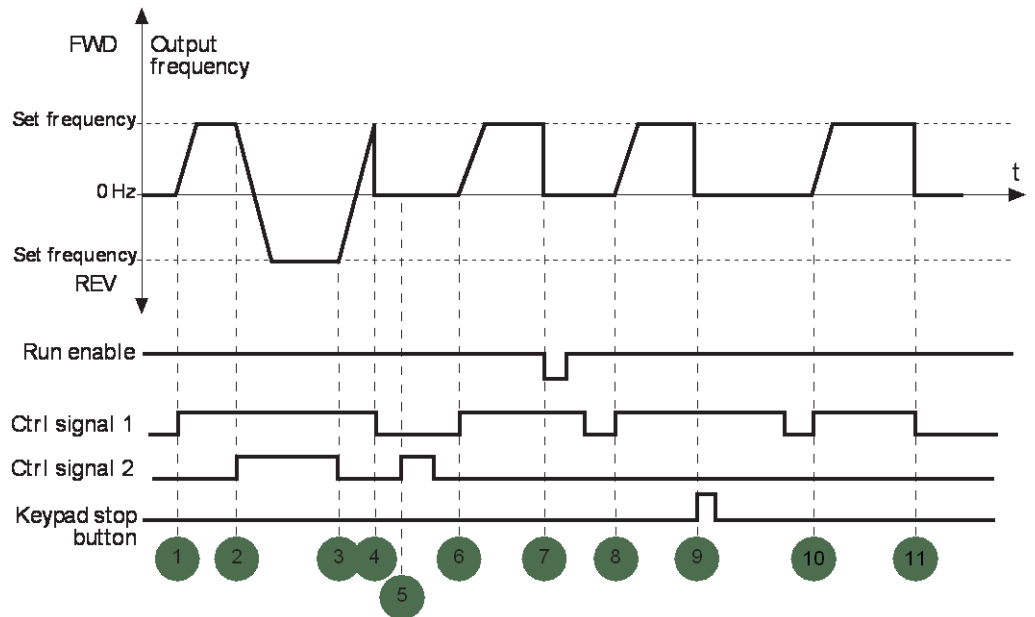

Figure 14: I/O A Start/Stop logic = 3.

Table 73: Legend

1	Control signal (CS) 1 activates causing the output frequency to rise. The motor runs forward.	7	Run enable signal is set to FALSE, which drops the frequency to 0. The run enable signal is configured with parameter P3.5.1.11.
2	CS2 activates which causes the direction to start changing (FWD to REV).	8	Run enable signal is set to TRUE, which causes the frequency to rise towards the set frequency because CS1 is still active.
3	CS2 is inactivated which causes the direction to start changing (REV to FWD) because CS1 is still active.	9	Keypad stop button is pressed and the frequency fed to the motor drops to 0. (This signal only works if P3.2.3 [→ 45] Keypad stop button [→ 45] = Yes)
4	Also CS1 inactivates and the frequency drops to 0.	10	The drive starts through pressing the Start button on the keypad.
5	Despite the activation of CS2, the motor does not start because CS1 is inactive.	11	The drive is stopped again with the stop button on the keypad.
6	CS1 activates causing the output frequency to rise again. The motor runs forward because CS2 is inactive.	12	The attempt to start the drive through pressing the Start button is not successful because CS1 is inactive.

Selection number	Selection name	Note
4	CS1: Start (edge) CS2: Reverse	Used to exclude the possibility of an unintentional start. The Start/Stop contact must be opened before the motor can be restarted.



11095.emf

Figure 15: I/O A Start/Stop logic = 4.

Table 74: Legend

1	Control signal (CS) 1 activates causing the output frequency to rise. The motor runs forward because CS2 is inactive.	7	Run enable signal is set to FALSE, which drops the frequency to 0. The run enable signal is configured with parameter P3.5.1.11.
2	CS2 activates which causes the direction to start changing (FWD to REV).	8	Before a successful start can take place, CS1 must be opened and closed again.
3	CS2 is inactivated which causes the direction to start changing (REV to FWD) because CS1 is still active.	9	Keypad stop button is pressed and the frequency fed to the motor drops to 0. (This signal only works if P3.2.3 [→ 45] Keypad stop button [→ 45] = Yes)
4	Also CS1 inactivates and the frequency drops to 0.	10	Before a successful start can take place, CS1 must be opened and closed again.
5	Despite the activation of CS2, the motor does not start because CS1 is inactive.	11	CS1 inactivates and the frequency drops to 0.
6	CS1 activates causing the output frequency to rise again. The motor runs forward because CS2 is inactive.		

Group 3.3: Control Reference Settings

Preset frequency mode (P3.3.10)

You can use the preset frequency parameters to define certain frequency references in advance. These references are then applied by activating/deactivating the digital inputs connected to parameters P3.5.1.15 [→ 50], P3.5.1.16 [→ 50] and P3.5.1.17 [→ 50] (Preset frequency selection 0 [→ 50], Preset frequency selection 1 [→ 50] and Preset frequency selection 2 [→ 50]). Two different logics can be selected:

Selection number	Selection name	Note
0	Binary coded	Combine activated inputs according to Table [→ 97] to choose the Preset frequency needed.
1	Number (of inputs used)	You can apply the <i>Preset frequencies</i> 1 to 3, depending on how many of the inputs assigned for <i>Preset frequency selections</i> are active.

Preset frequencies 1 to 7 (P3.3.11 to P3.3.18)

The values of the preset frequencies are automatically limited between the minimum and maximum frequencies (P3.3.1 [→ 46] and P3.3.2 [→ 46]). See the following Table.

Table 75: Selection of preset frequencies.

Required action			Activated frequency
Bold = input activated.			
Choose value 1 for parameter P3.3.3 [→ 46]			Preset frequency 0 [→ 50]
B2	B1	B0	Preset frequency 1 [→ 50]
B2	B1	B0	Preset frequency 2 [→ 50]
B2	B1	B0	Preset frequency 3 [→ 50]
B2	B1	B0	Preset frequency 4 [→ 50]
B2	B1	B0	Preset frequency 5 [→ 50]
B2	B1	B0	Preset frequency 6 [→ 50]
B2	B1	B0	Preset frequency 7 [→ 50]

Group 3.4: Ramp & Brakes Setup

Ramp 1 shape (P3.4.1)

The start and end of acceleration and deceleration ramps can be smoothed with this parameter. Setting value 0 gives a linear ramp shape which causes acceleration and deceleration to act immediately to the changes in the reference signal.

Setting value 0.1...10 seconds for this parameter produces an S-shaped acceleration/deceleration. The acceleration time is determined with parameters P3.4.2 [→ 49] and P3.4.3 [→ 49]. See the following Figure.

These parameters are used to reduce mechanical erosion and current spikes when the reference is changed.

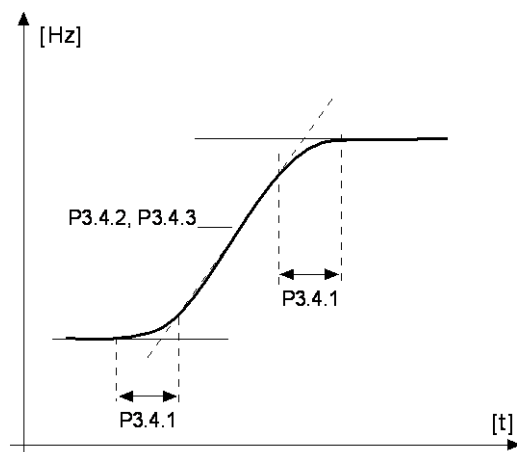

11096.emf

Figure 16: Acceleration/Deceleration (S-shaped).

Flux braking (P3.4.12)

Instead of DC braking, flux braking is a useful way to raise the braking capacity in cases where additional brake resistors are not needed.

When braking is needed, the frequency is reduced and the flux in the motor is increased, which in turn increases the motor's capability to brake. Unlike DC braking, the motor speed remains controlled during braking.

The flux braking can be set ON or OFF.



NOTE:

Flux braking converts the energy into heat at the motor, and should be used intermittently to avoid motor damage.

Group 3.5: I/O Configuration

Run enable (P3.5.1.11)

Contact open: Start of motor **disabled**
 Contact closed: Start of motor **enabled**

The variable frequency drive is stopped according to the selected function at P3.2.5 [→ 45]. The follower drive will always coast to stop.

Run interlock 1 (P3.5.1.12)

Run interlock 2 (P3.5.1.13 [→ 50])

The drive cannot be started if any of the interlocks are open.

The function could be used for a damper interlock, preventing the drive to start with damper closed.

Preset frequency selection 0 (P3.5.1.15)

Preset frequency selection 1 (P3.5.1.16)

Preset frequency selection 2 (P3.5.1.17 [→ 50])

Connect a digital input to these functions with the programming method presented on page [→ 40] to be able to apply Preset frequencies 1 to 7 (see the Table on page [→ 104]).

All1 signal filter time (P3.5.2.2 [→ 52])

When this parameter is given a value greater than 0 the function that filters out disturbances from the incoming analog signal is activated.



NOTE:

Long filtering time makes the regulation response slower!

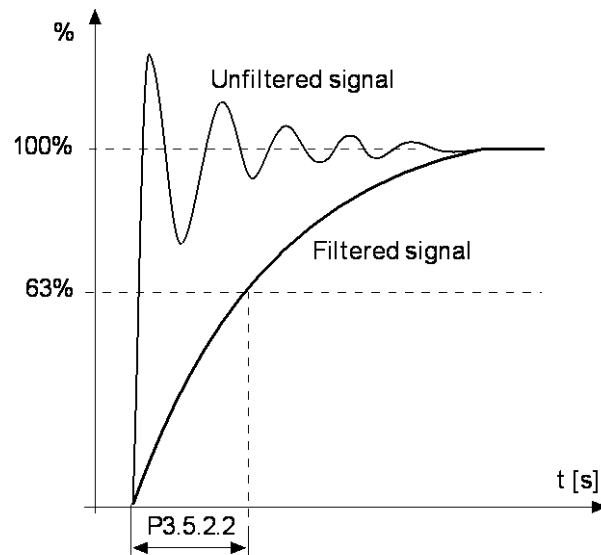

11097.emf

Figure 17: All1 signal filtering.

Basic RO1 function (P3.5.3.2.1)

Table 76: Output signals via RO1.

Selection	Selection name	Description
0	Not used	
1	Ready	The variable frequency drive is ready to operate
2	Run	The variable frequency drive operates (motor is running)
3	General fault	A fault trip has occurred
4	General fault inverted	A fault trip has <i>not</i> occurred
5	General alarm	
6	Reversed	The reverse command has been selected
7	At speed	The output frequency has reached the set reference
8	Motor regulator activated	One of the limit regulators (e.g. current limit, torque limit) is activated
9	Preset frequency active	The preset frequency has been selected with digital input
10	Keypad control active	Keypad control mode selected
11	I/O control B active	I/O control place B selected
12	Limit supervision 1	Activates if the signal value falls below or exceeds the set supervision limit (P3.8.3 [→ 58] or P3.8.7 [→ 58]) depending on the selected function.
13	Limit supervision 2	
14	Start command active	Start command is active.
15	Reserved	
16	Fire mode ON	
17	RTC timer 1 control	Time channel 1 is used.
18	RTC timer 2 control	Time channel 2 is used.
19	RTC timer 3 control	Time channel 3 is used.
20	FB Control WordB.13	
21	FB Control WordB.14	
22	FB Control WordB.15	
23	PID1 in Sleep mode	
24	Reserved	
25	PID1 supervision limits	PID1 feedback value is beyond supervision limits.

Selection	Selection name	Description
26	PID2 supervision limits	PID2 feedback value is beyond supervision limits.
27	Motor 1 control	Contactora control for <i>Multi-pump</i> function
28	Motor 2 control	Contactora control for <i>Multi-pump</i> function
29	Motor 3 control	Contactora control for <i>Multi-pump</i> function
30	Motor 4 control	Contactora control for <i>Multi-pump</i> function
31	Reserved	(Always open)
32	Reserved	(Always open)
33	Reserved	(Always open)
34	Maintenance warning	
35	Maintenance fault	
36	Thermistor fault	
37	Motor switch	
38	Bypass active	Selects relay output for the Bypass active signal. This signal is on when the drive is in Bypass mode.
39	Bypass running	Selects relay output terminal for Bypass contactora control.
40	Drive active	Selects relay output for the Drive active signal. This signal is on when the drive is in Drive mode.
41	Drive output contactora	Controls the Drives Output contactora.
42	Overload Fault	Selects relay output for the Overload fault signal. This signal is on when the Overload fault is active.
43	Essential Services active	Selects relay output for the Essential services signal.
44	Auto Bypass active	Selects relay output for the Auto Bypass active signal
45	Interlock Proofing	Selects relay output for the Interlock Proofing signal.
46	Interlock Proofed	Selects relay output for the Interlock Proofed signal.
47	Stop Forced	Selects relay output for the Local Stop Forced from keypad signal.
48	Remote Start	Selects relay output for the Remote Start signal

Group 3.9: Protections

Response to external fault (P3.9.2 [→ 59])

An alarm message or a fault action and message is generated by an external fault external fault signal in one of the programmable digital inputs (DI3 by default) using parameters P3.5.1.7 [→ 50] and P3.5.1.8 [→ 50]. The information can also be programmed into any of the relay outputs.

Motor thermal zero speed cooling (P3.9.8 [→ 59])

Defines the cooling factor at zero speed in relation to the point where the motor is running at nominal speed without external cooling. See the Table *Protections Settings* in the *Protections (M3.9)* section [→ 59].

The default value is set assuming that there is no external fan cooling the motor. If an external fan is used this parameter can be set to 90% (or even higher).

If you change the parameter P3.1.1.4 [→ 42] Motor nominal current, this parameter is automatically restored to the default value.

Setting this parameter does not affect the maximum output current of the drive which is determined by parameter P3.1.1.7 [→ 42] alone.

The corner frequency for the thermal protection is 70% of the motor nominal frequency (P3.1.1.2 [→ 42]).

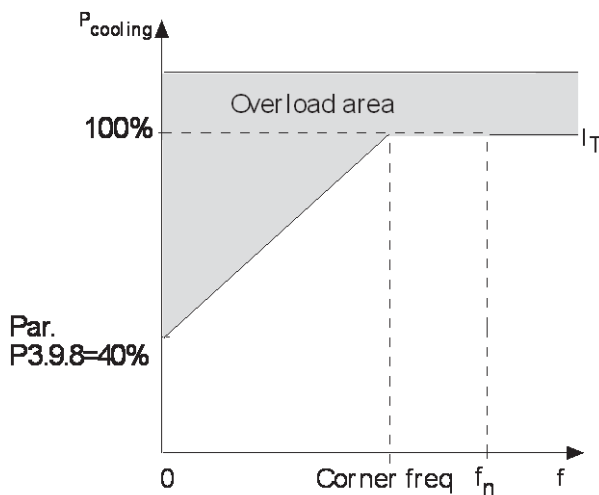

Figure 18: Motor thermal current I_T curve.

Motor thermal time constant (P3.9.9 [→ 59])

The time constant is the time within which the calculated thermal stage has reached 63% of its final

value. The bigger the frame and/or the slower the speed of the motor, the longer the time constant.

The motor thermal time is specific to the motor design and it varies between different motor

manufacturers. The default value of the parameter varies from size to size.

If the motor's t_6 -time (t_6 is the time in seconds the motor can safely operate at six times the rated current) is known (given by the motor manufacturer), the time constant

parameter can be set based on it. As a rule of thumb, the motor thermal time constant in minutes is equal to $2 \cdot t_6$. If the drive is in stop stage, the time constant is internally increased to three times the set parameter value. The cooling in stop stage is based on convection and the time constant is increased. See the Figure *Motor Temperature Calculation*.

Motor thermal load (P3.9.10)

Setting the value to 130% means that the nominal temperature will be reached with 130% of the motor's nominal current.

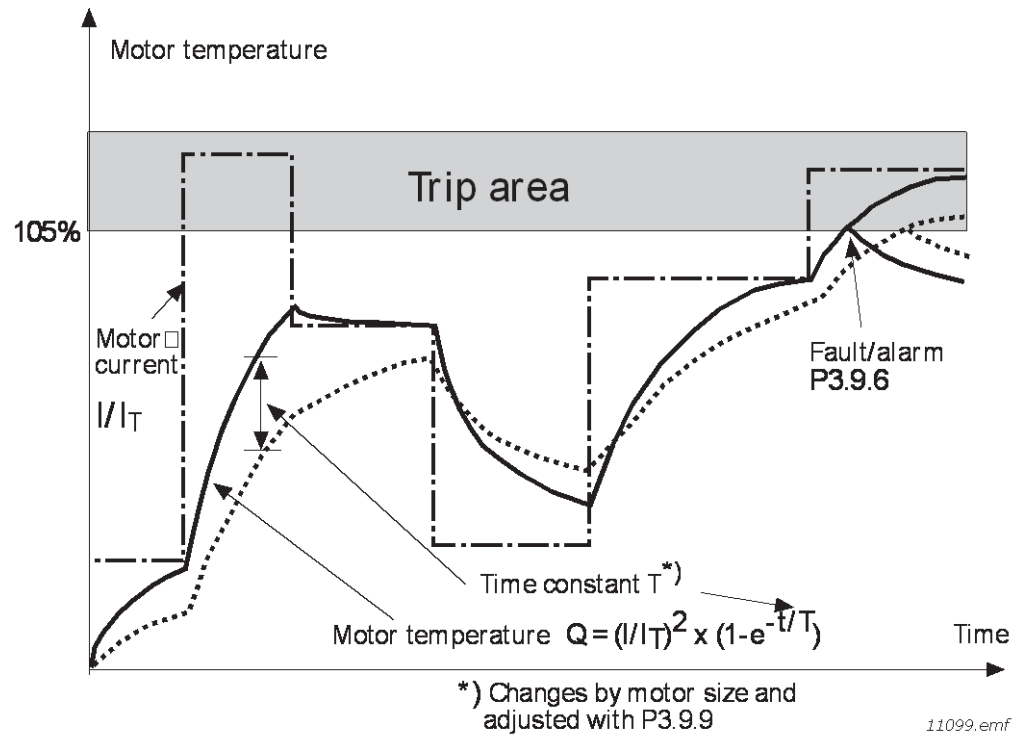

Figure 19: Motor Temperature Calculation.

Stall current (P3.9.12)

The current can be set to $0.0 \dots 2 \cdot I_L$. For a stall stage to occur, the current must have exceeded this limit. See the following Figure. If parameter P3.1.1.7 Motor current limit is changed, this parameter is automatically calculated to 90% of the current limit. See page [→ 97].



NOTE:

In order to guarantee desired operation, this limit must be set below the current limit.

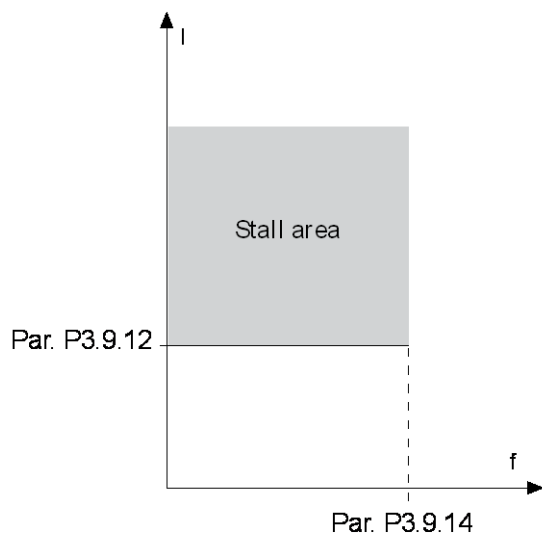

11100.emf

Figure 20: Stall characteristics settings.

Stall time limit (P3.9.13)

This time can be set between 1.0 and 120.0s.

This is the maximum time allowed for a stall stage. The stall time is counted by an internal up/down counter.

If the stall time counter value goes above this limit, the protection will cause a trip (see *Parameters of Stall Protection* (P3.9.11) [→ 59]).

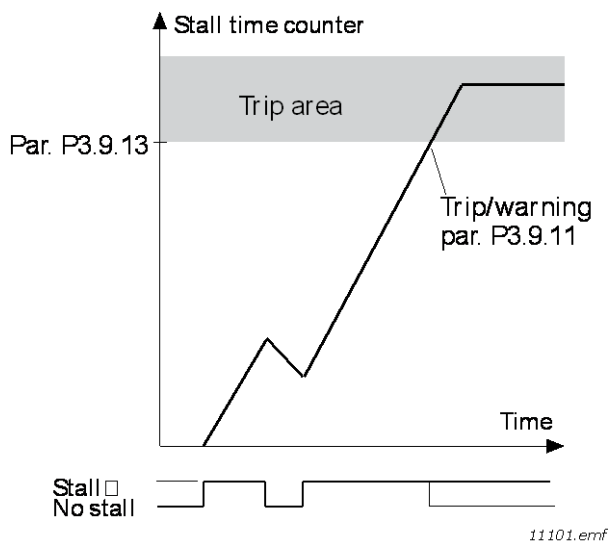

11101.emf

Figure 21: Stall time count.

Underload protection: Field weakening area load (P3.9.16)

The torque limit can be set between 10.0-150.0% $\times T_n$ Motor.

This parameter gives the value for the minimum torque allowed when the output frequency is above the field weakening point. See the following Figure.

If you change parameter P3.1.1.4 (Motor nominal current), this parameter is automatically restored to the default value. See page [→ 60].

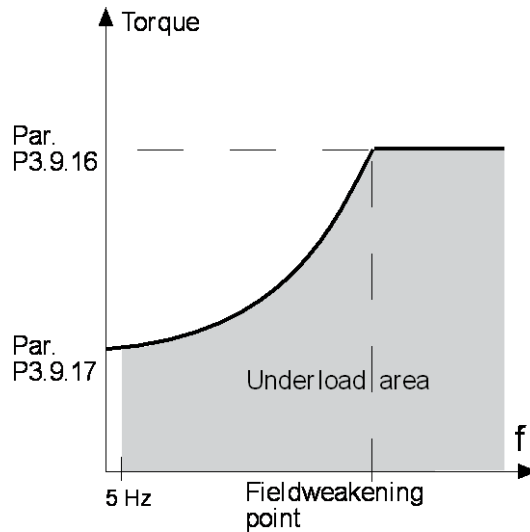

11102.emf

Figure 22: Setting of minimum load.

Underload protection: Time limit (P3.9.18)

This time can be set between 2.0 and 600.0 s.

This is the maximum time allowed for an underload state to exist. An internal up/down counter counts the accumulated underload time. If the underload counter value goes above this limit the protection will cause a trip according to parameter P3.9.15). If the drive is stopped the underload counter is reset to zero. See the following Figure and page [→ 60].

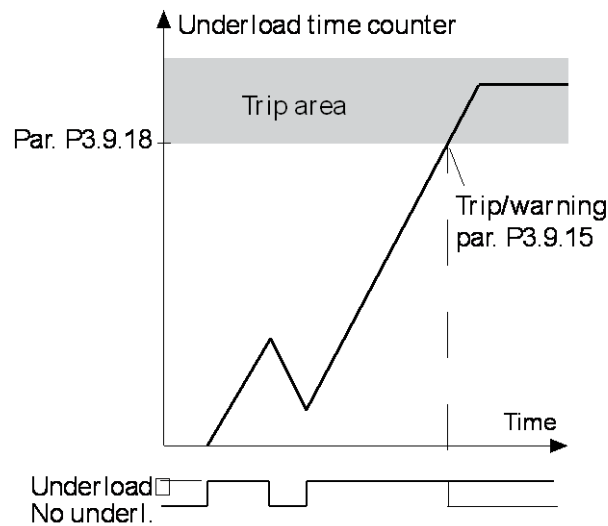

11103.emf

Figure 23: Underload time counter function.

Group 3.10: Automatic Reset

Automatic reset (P3.10.1 [→ 63])

Activate the *Automatic reset* after fault with this parameter.



NOTE:

Automatic reset is allowed for certain faults only. By giving the parameters P3.10.6 [→ 63] to P3.10.13 [→ 63] the value 0 or 1 you can either allow or deny the automatic reset after the respective faults.

Wait time (P3.10.3)

Automatic reset: Trial time (P3.10.4)

Number of trials (P3.10.5)

The Automatic reset function keeps resetting the faults appearing during the time set with this parameter. If the number of faults during the trial time exceed the value of parameter P3.10.5, a permanent fault is generated. Otherwise the fault is cleared after the trial time has elapsed and the next fault starts the trial time count again.

Parameter P3.10.5 determines the maximum number of automatic fault reset attempts during the trial time set by this parameter. The time count starts from the first auto-reset. The maximum number is independent of the fault type.

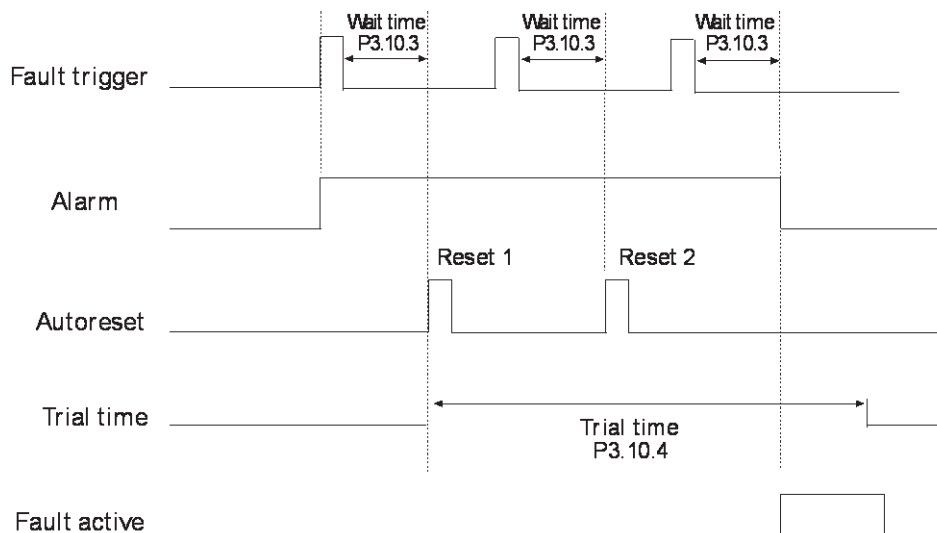

Number of trials: (P3.10.5 = 2)

11104.emf

Figure 24: Automatic reset function.

Group 3.12: PID Controller 1

Dead band hysteresis (P3.12.1.9)

Dead band delay (P3.12.1.10)

The PID controller output is locked if the actual value stays within the dead band area around the reference for a predefined time. This function will prevent unnecessary movement and wear on actuators, e.g. valves.

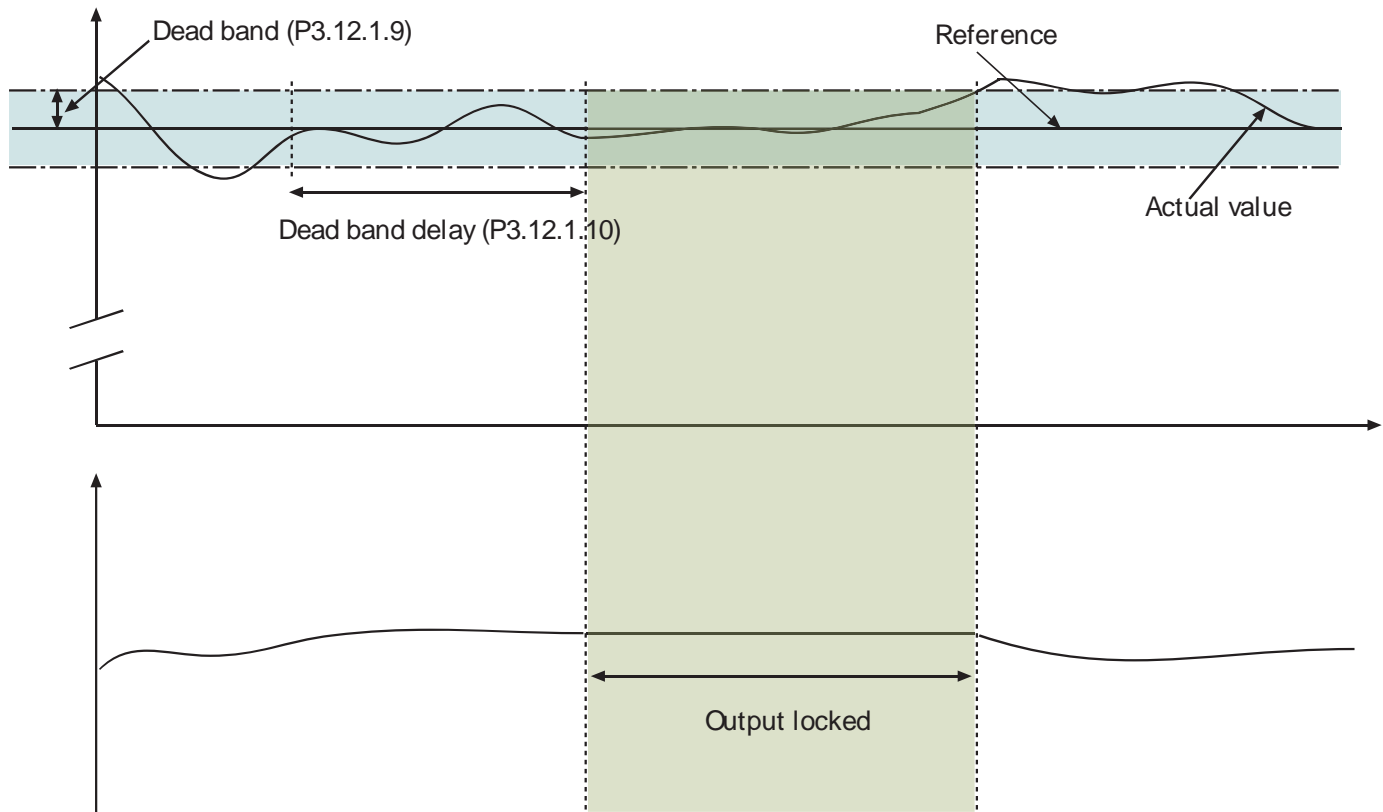

11105.emf

Figure 25: Dead band.

Sleep frequency limit 1 (P3.12.2.7)

Sleep delay 1 (P3.12.2.8)

Wake-up level 1 (P3.12.2.9)

This function will put the drive into sleep mode if the frequency stays below the sleep limit for a longer period than that set with the Sleep Delay (P3.12.2.8). This means that the start command remains on, but the run request is turned off. When the actual value goes below or above the wake-up level depending on the set acting mode, the drive will activate the run request again, if the start command is still on.

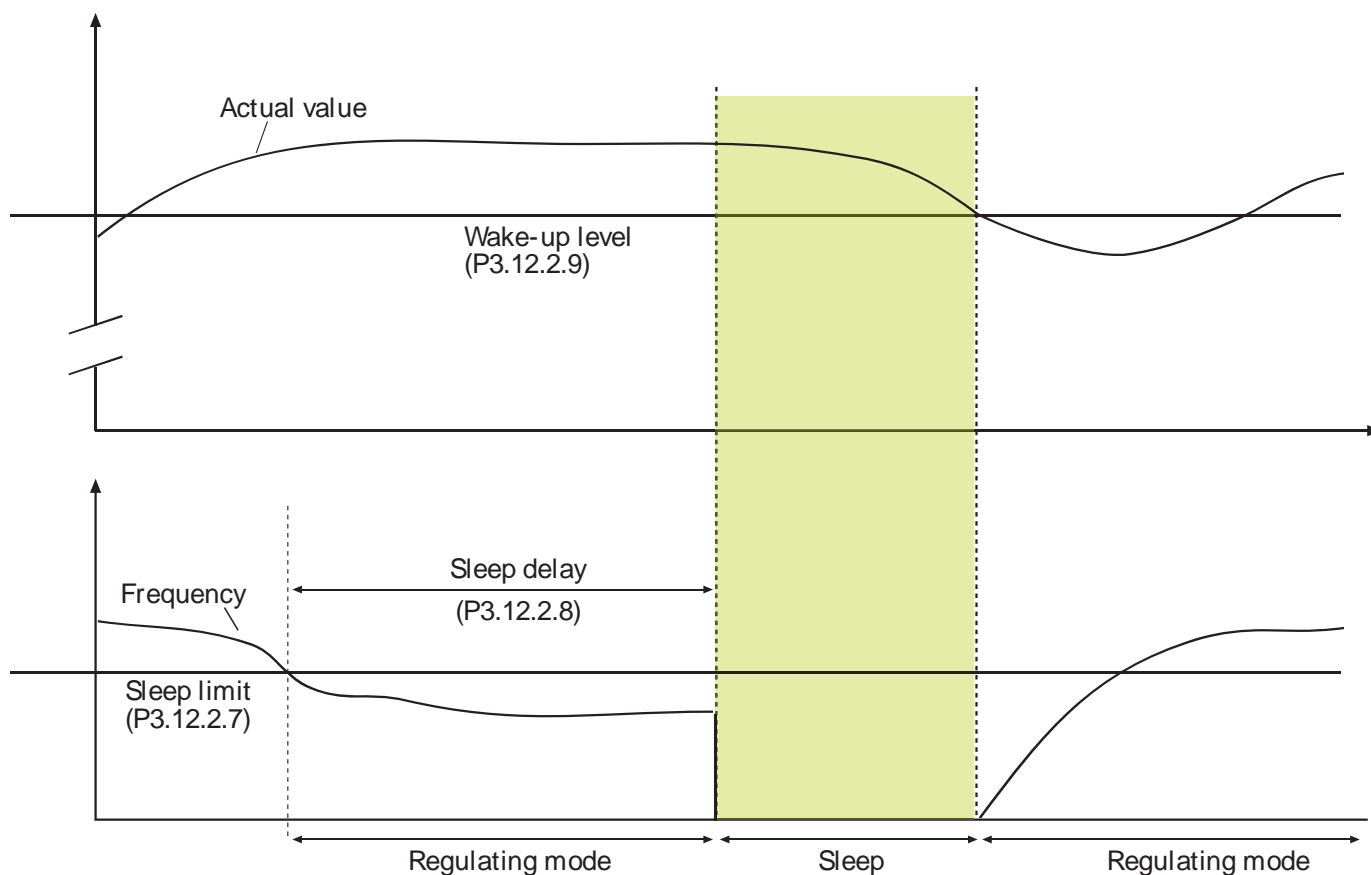

11106.emf

Figure 26: Sleep limit, Sleep delay, Wake-up level.

Feedforward function (P3.12.4.1)

Feedforward usually needs accurate process models, but in some cases, a gain + offset type of feedforward is enough. The feedforward part does not use any feedback measurements of the actual controlled process value (water level in the following Example). Siemens feedforward control uses other measurements which are indirectly affecting the controlled process value.

Example 1:

Controlling the water level of a tank by means of flow control. The desired water level has been defined as a setpoint and the actual level as feedback. The control signal acts on the incoming flow.

The outflow could be thought of as a disturbance that can be measured. Based on the measurements of the disturbance, we can try to compensate for this disturbance with a simple feedforward control (gain and offset) which is added to the PID output.

This way, the controller will react much faster to changes in the outflow than if you had just measured the level.

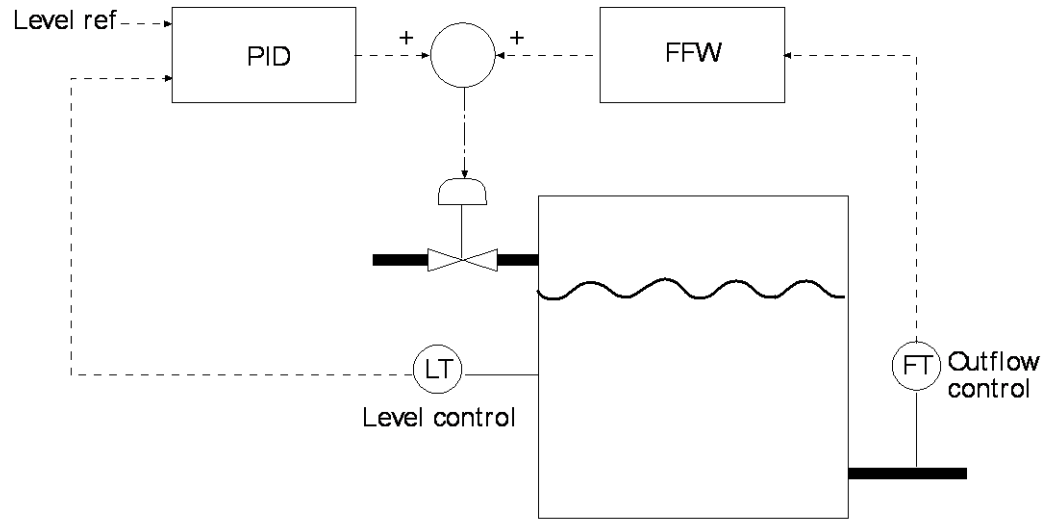

11107.emf

Figure 27: Feedforward control.

Enable process supervision (P3.12.5.1)

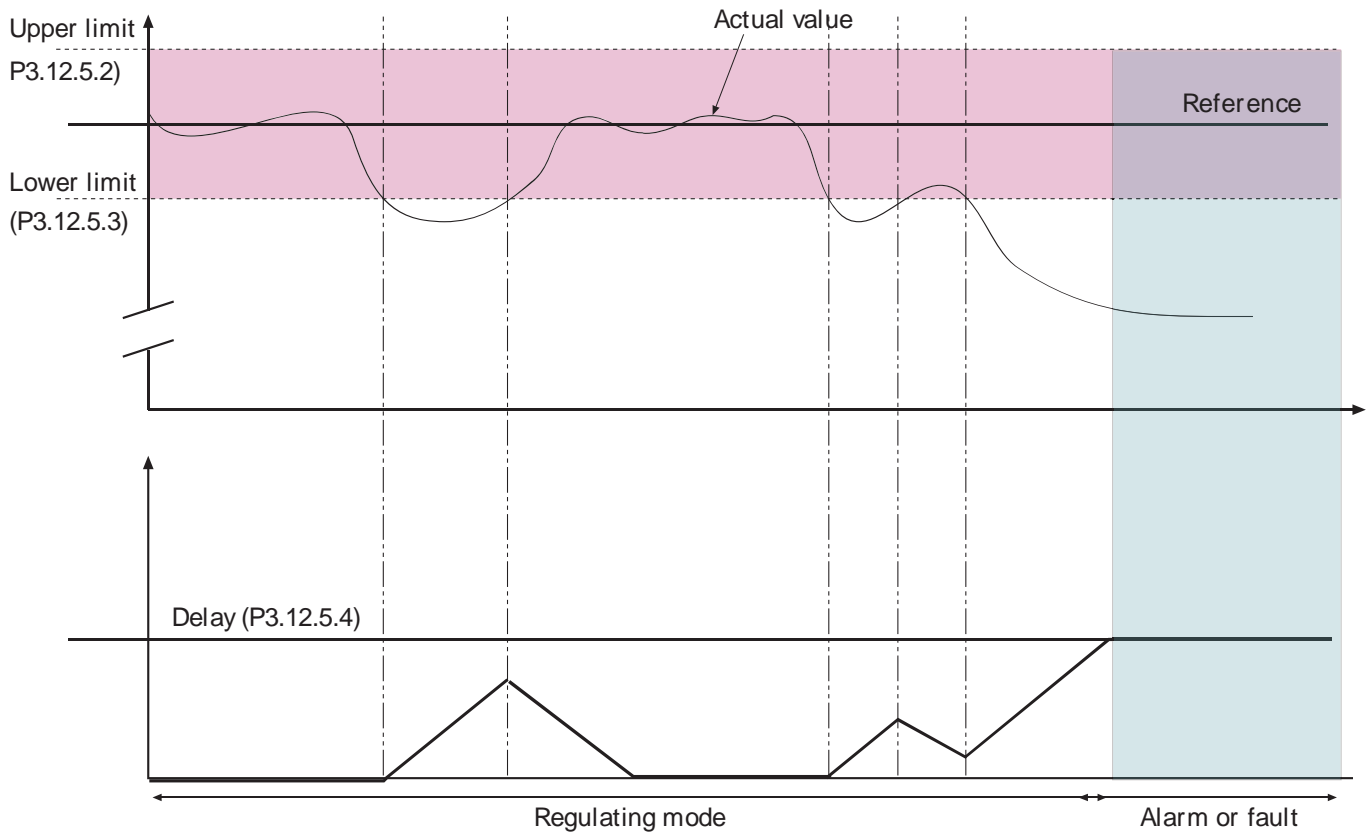

11108.emf

Figure 28: Process supervision.

Upper and lower limits around the reference are set. When the actual value goes above or below, a counter starts counting up towards the Delay (P3.12.5.4 [→ 74]). When the actual value is within the allowed area, the same counter counts down instead. Whenever the counter is higher than the Delay, an alarm or fault (depending on the selected response) is generated.

Pressure Loss Compensation

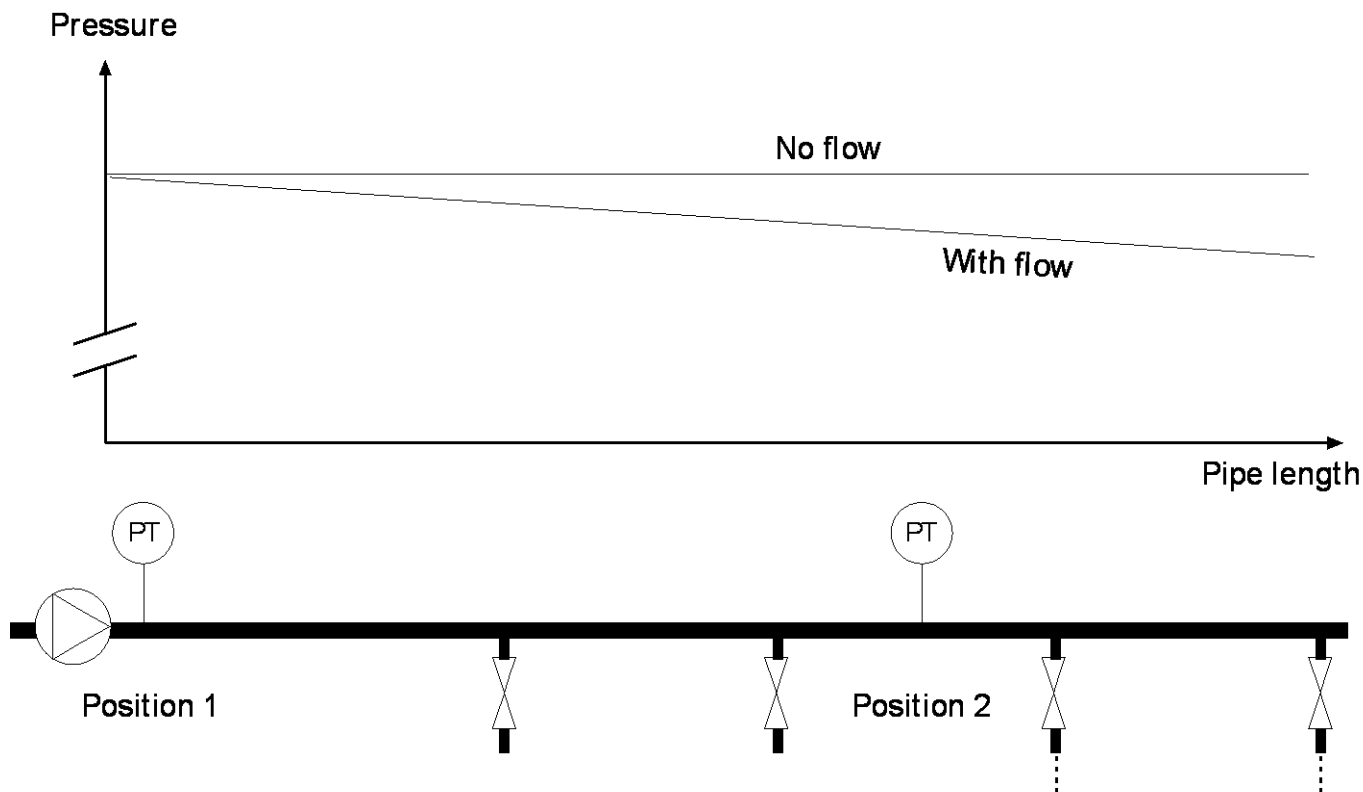

11109.emf

Figure 29: Position of pressure sensor.

If pressurizing a long pipe with many outlets, the best place for the sensor is probably halfway down the pipe (Position 2). However, sensors may, for example, be placed directly after the pump. This will give the right pressure directly after the pump, but farther down in the pipe the pressure will drop depending on the flow.

Enable setpoint 1 (P3.12.6.1)

Setpoint 1 max compensation (P3.12.6.2)

The sensor is placed in Position 1. The pressure in the pipe will remain constant when we have no flow. However, with flow, the pressure will drop farther down in the pipe. This can be compensated by raising the setpoint as the flow increases. In this case, the flow is estimated by the output frequency and the setpoint is linearly increased with the flow as in the figure below.

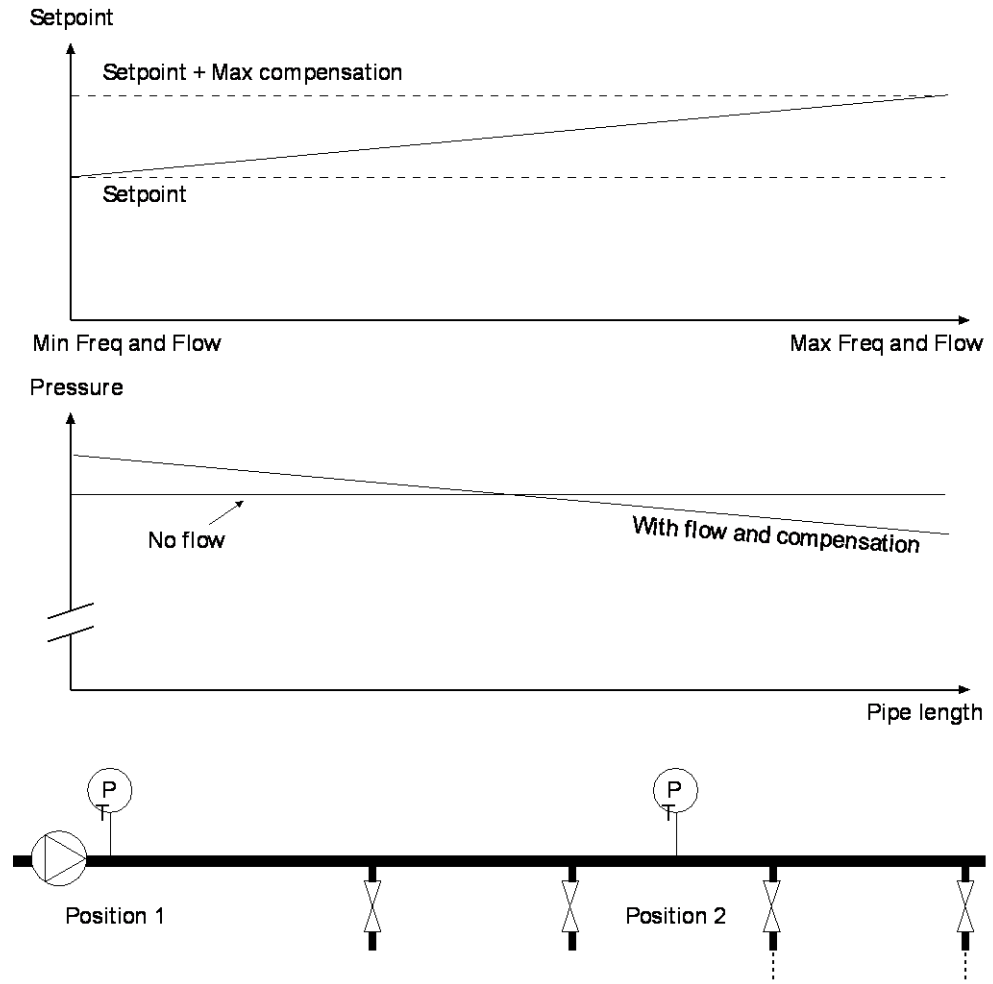

11110.emf

Figure 30: Enable setpoint 1 for pressure loss compensation.

Group 3.14: Multi-Pump

Motors are connected/disconnected if the PID controller is not able to keep the process value or feedback within the defined bandwidth around the setpoint.

Criteria for connecting/adding motors (also see the following Figure):

- Feedback value outside the bandwidth area.
- Regulating motor running at a “close-to-max” frequency (-2Hz).
- Conditions above are fulfilled for a time longer than the bandwidth delay.
- There are additional motors available.

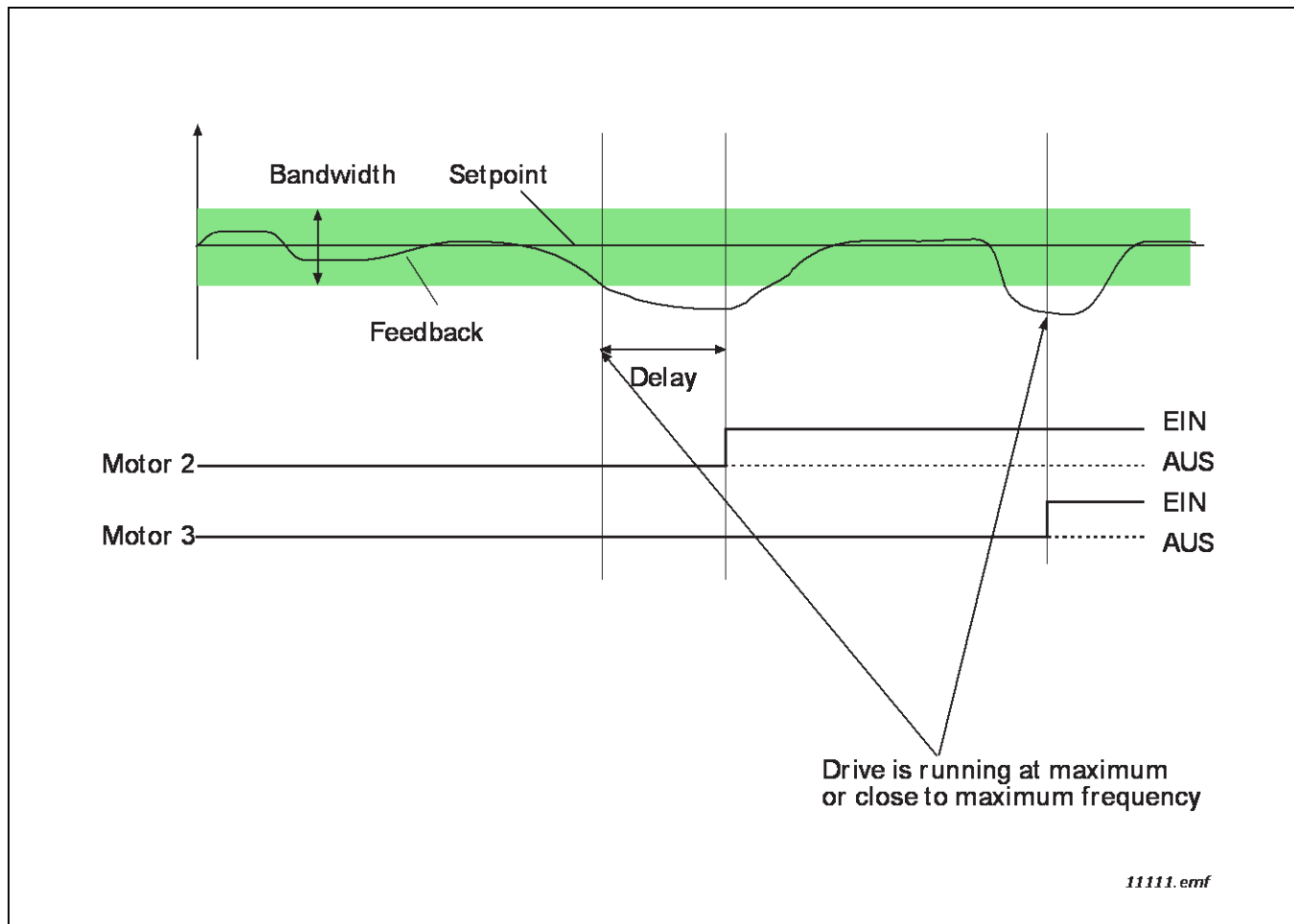

Figure 31:

Criteria for disconnecting/removing motors:

- Feedback value outside bandwidth area.
- Regulating motor running at a “close-to-min” frequency (+2 Hz).
- Conditions above are fulfilled for a time longer than the bandwidth delay
- There are more motors running than the regulating one.

Interlock function (P3.14.2)

Interlocks can be used to tell the Multi Pump system that a motor is not available, e.g. because the motor is removed from the system for maintenance or bypassed for manual control.

Enable this function to use the interlocks. Choose the needed status for each motor by digital inputs (parameters P3.5.1.26 to P3.5.1.30). If the input is closed (TRUE) the motor is available for the Multi Pump system, otherwise it will not be connected by the Multi Pump logic.

Example of the Interlock logic:

If the motor starting order is

1->2->3->4->5

When the interlock of motor 3 is removed, i.e. the value of parameter P3.5.1.28 [→ 50] is set to FALSE, the order changes to:

1->2->4->5.

If motor 3 is taken into use again (changing the value of parameter P3.5.1.28 [→ 50] to TRUE), the system runs without stopping and motor 3 is placed last in the sequence:

1->2->4->5->3

The next time the system is stopped or goes to sleep mode, the sequence returns to its original order.

1->2->3->4->5

Include FC (P3.14.3 [→ 80])

Selection	Selection name	Description
0	Disabled	Motor 1 (motor connected to variable frequency drive) is always frequency controlled and not affected by interlocks.
1	Enabled	All motors can be controlled and are affected by interlocks.

Wiring

There are two different ways to make the connections depending on whether selection 0 or 1 is set as parameter value.

Selection 0, Disabled:

The variable frequency drive or the regulating motor is not included in the auto-change or interlocks logic. The drive is directly connected to motor 1 as in the following Figure. The other motors are auxiliary ones connected to the mains by contactors and controlled by relays in the drive.

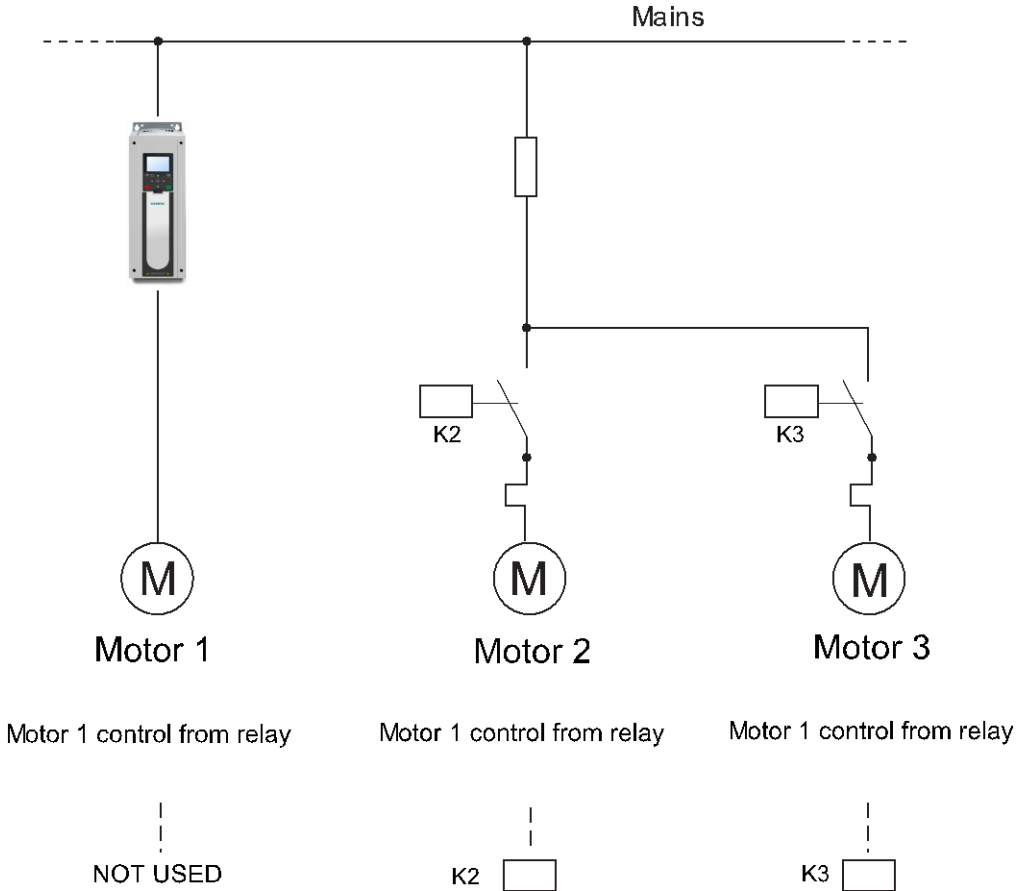

BT11112

Selection 1, Enabled:

If the regulating motor needs to be included in the auto-change or interlock logic make the connection according to the following Figure.

Each motor is controlled by a relay, but the contact logic ensures that the first connected motor is always connected to the drive and near the mains.

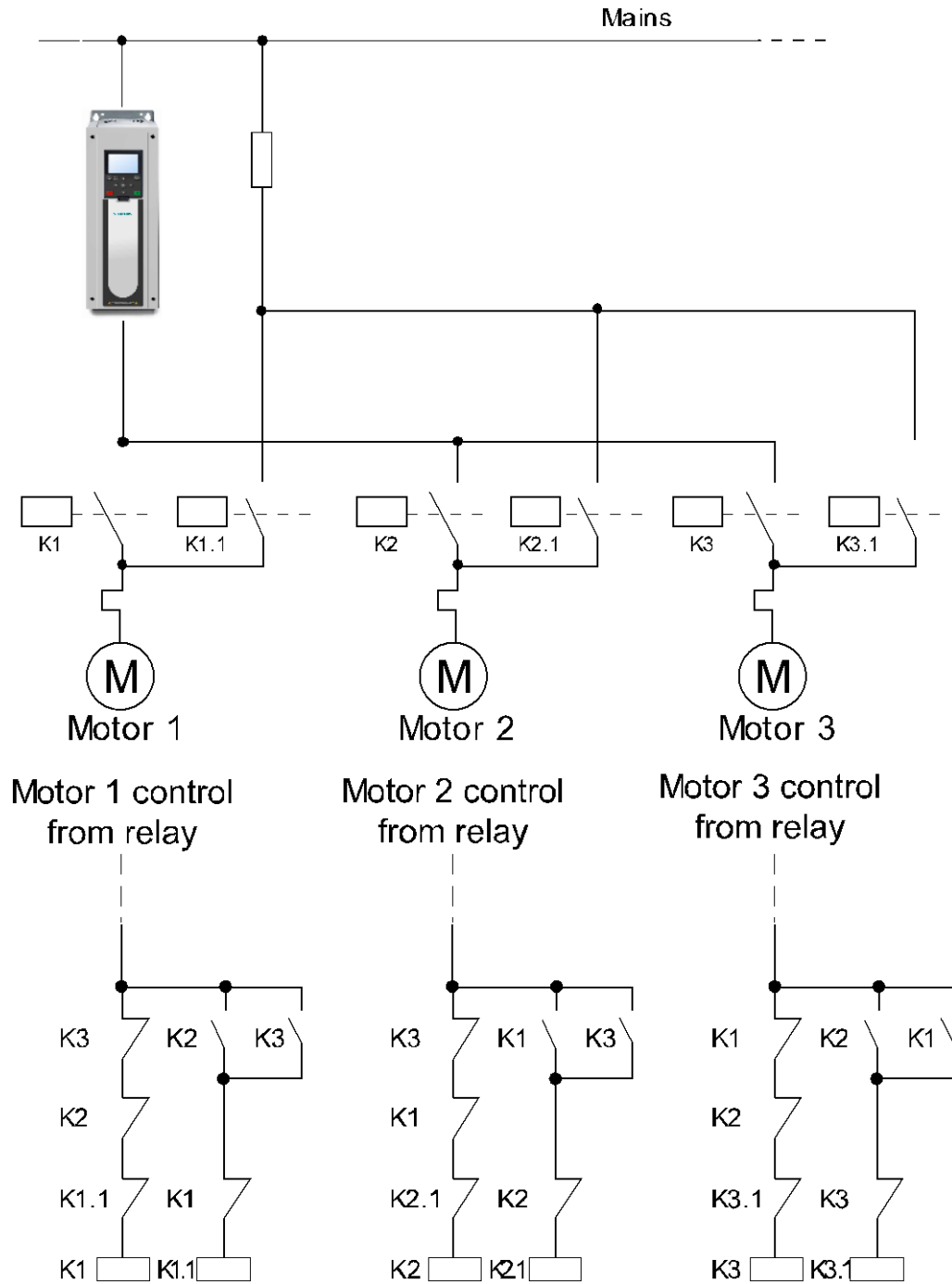

BT11113

Figure 32:

Auto-change (P3.14.4)

Selection	Selection name	Description
0	Disabled	The priority/starting order of the motors is always 1-2-3-4-5 in normal operation. It may have changed during its run if interlocks have been removed and added again, but the priority/order is always restored after a stop.
1	Enabled	The priority is changed at certain intervals to get an equal wear on all motors. The intervals of the auto-change can be changed (P3.14.5). You can also set a limit for how many motors are allowed to run (P3.14.7 [→ 80]) as well as for the maximum frequency of the regulating drive when the auto-change is done (P3.14.6 [→ 80]). If the auto-change interval P3.14.5 has expired, but the frequency and motor limits are not fulfilled, the auto-change will be postponed until all conditions are met (this is to avoid for example sudden pressure drops while the system is performing an auto-change when there is a high capacity demand at a pump station).

Example:

In the auto-change sequence after the auto-change has taken place, the motor with the highest priority is placed last and the others are moved up by one place:

Starting order/priority of motors: 1->2->3->4->5

--> *Autochange* -->

Starting order/priority of motors: 2->3->4->5->1

--> *Autochange* -->

Starting order/priority of motors: 3->4->5->1->2

Chapter 10 - Fault tracing

When the drive control diagnostics detect an unusual operating condition, the drive initiates a visible notification on the keypad. The keypad will show the code, the name and a short description of the fault or alarm.

Notifications vary in consequence and required action. *Faults* make the drive stop and require a reset of the drive. *Alarms* inform of unusual operating conditions, but the drive will continue to run. *Infos* may require resetting but do not affect the drive's operation.

For some faults, you can program different responses in the application. See the parameter group Protections [→ 59].

The fault can be reset with the *Reset button* on the control keypad or via the I/O terminal. The faults are stored in the Fault history menu which can be browsed. Fault codes are outlined in the following Table.



NOTE:

When contacting Siemens because of a fault condition, contact Technical Support at 1-800-877-7545 (Dial 2).

Always write down all texts and codes on the keypad display and a description of the problem together with the Drive Info file.

Fault Displays

When a fault displays and the drive stops, examine the cause of the fault, perform the actions advised here and reset the fault as instructed below.

1. Press the **Reset** button on the keypad for one second or
2. By entering the **Diagnostics** Menu (M4), entering **Reset faults** (M4.2) and selecting **Reset faults** parameter.

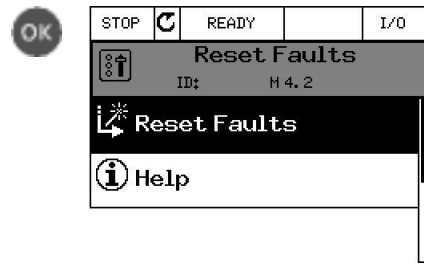
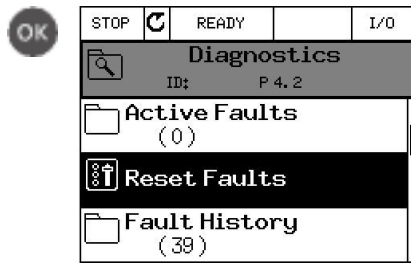
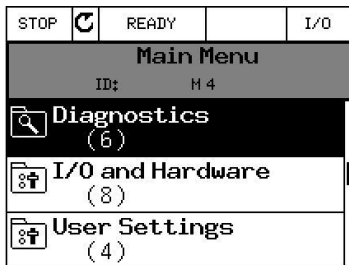

Fault history

In menu M4.3, Fault history, you find the maximum number of 40 occurred faults. On each fault in the memory you will also find additional information. See the following Figure.

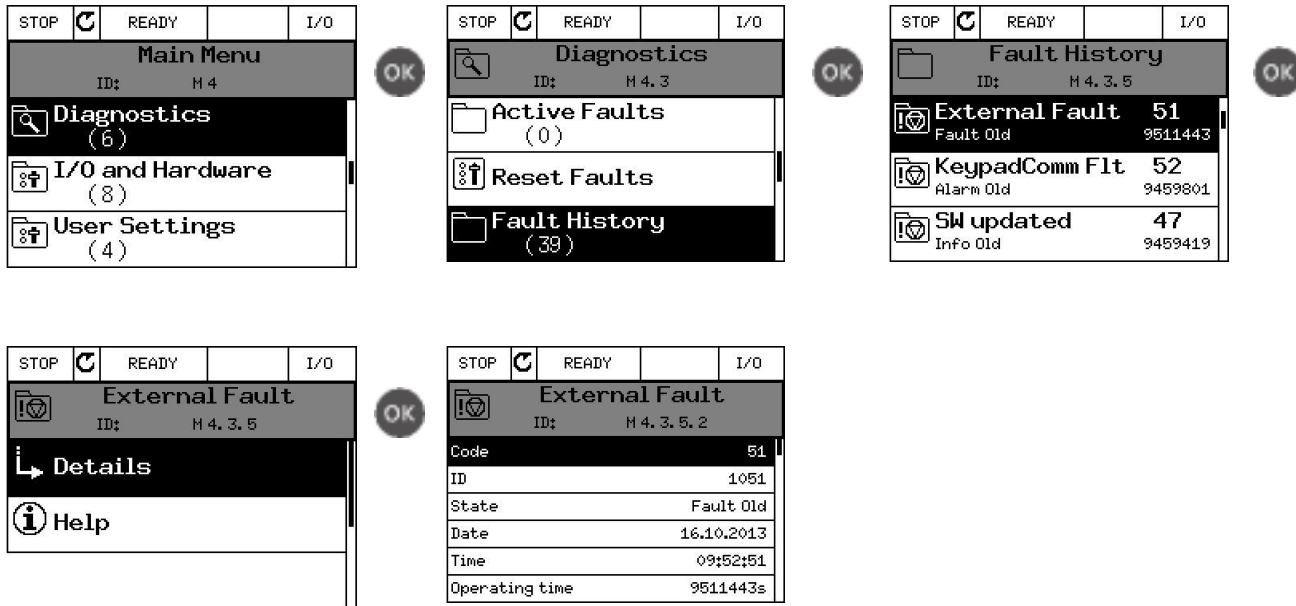

Fault codes

Table 77: Fault codes and descriptions.

Fault code	Fault ID	Fault name	Possible cause	Remedy
1	1	Over-current (hardware fault)	The drive has detected too high a current (>4*I _H) in the motor cable: <ul style="list-style-type: none"> • sudden heavy load increase • short circuit in motor cables • unsuitable motor 	Check loading. Check motor. Check cables and connections. Make identification run. Check ramp times.
	2	Over-current (software fault)		
2	10	Over-voltage (hardware fault)	The DC-link voltage has exceeded the limits defined. <ul style="list-style-type: none"> • too short a deceleration time • high over-voltage spikes in supply • Start/Stop sequence too fast 	Make deceleration time longer. Activate overvoltage controller. Check input voltage.
	11	Over-voltage (software fault)		
3	20	Earth fault (hardware fault)	Current measurement has detected that the sum of motor phase current is not zero. <ul style="list-style-type: none"> • insulation failure in cables or motor 	Check motor cables and motor.
	21	Earth fault (software fault)		

Fault code	Fault ID	Fault name	Possible cause	Remedy
5	40	Charging switch	The charging switch is open, when the START command has been given. <ul style="list-style-type: none"> ● faulty operation ● component failure 	Reset the fault and restart. Should the fault re-occur, contact the distributor near to you.
7	60	Saturation	Various causes: <ul style="list-style-type: none"> ● defective component ● brake resistor short-circuit or overload 	Cannot be reset from keypad. Switch off power. DO NOT RE-CONNECT POWER! Contact factory. If this fault appears simultaneously with F1, check motor cables and motor.
8	600	System fault	Communication between control board and power unit has failed.	Reset the fault and restart. Should the fault re-occur, contact your distributor.
	602		Watchdog has reset the CPU.	
	603		Voltage of auxiliary power in power unit is too low.	
	604		Phase fault: Voltage of an output phase does not follow the reference.	
	605		CPLD has faulted but there is no detailed information about the fault.	
	606		Control and power unit software are incompatible.	Update software. Should the fault re-occur, contact your distributor.
	607		Software version cannot be read. There is no software in the power unit.	Update power unit software. Should the fault re-occur, contact your distributor.
	608		CPU overload. Part of the software (for example the application) has caused an overload situation. The source of the fault has been suspended.	Reset the fault and restart. Should the fault re-occur, contact your distributor.
	609		Memory access has failed. For example, retain variables could not be restored.	
	610		Necessary device properties cannot be read.	
	647		Software error.	Update software. Should the fault re-occur, contact your distributor.
	648		Invalid function block used in application. System software and application are not compatible.	
649		Resource overload. Error when loading parameter initial values. Error when restoring parameters. Error when saving parameters.		

Fault code	Fault ID	Fault name	Possible cause	Remedy
9	80	Undervoltage (fault)	DC-link voltage is under the voltage limits defined. <ul style="list-style-type: none"> ● most probable cause: too low a supply voltage ● AC drive internal fault ● defect input fuse ● external charge switch not closed NOTE: This fault is activated only if the drive is in Run state.	In case of temporary supply voltage break reset the fault and restart the AC drive. Check the supply voltage. If it is adequate, an internal failure has occurred. Contact your distributor..
	81	Undervoltage (alarm)		
10	91	Input phase	Input line phase is missing.	Check supply voltage, fuses and cable.
11	100	Output phase supervision	Current measurement has detected that there is no current in one motor phase.	Check motor cable and motor.
13	120	AC drive undertemperature (fault)	Too low temperature measured in power unit's heatsink or board. Heatsink temperature is under -10°C (14°F).	
	121	AC drive undertemperature (alarm)		
14	130	AC drive overtemperature (fault, heatsink)	Too high temperature measured in power unit's heatsink or board. Heatsink temperature is over 100°C (212°F).	Check the correct amount and flow of cooling air. Check the heatsink for dust. Check the ambient temperature. Make sure that the switching frequency is not too high in relation to ambient temperature and motor load.
	131	AC drive overtemperature (alarm, heatsink)		
	132	AC drive overtemperature (fault, board)		
	133	AC drive overtemperature (alarm, board)		
15	140	Motor stalled	Motor is stalled.	Check motor and load.
16	150	Motor overtemperature	Motor is overloaded.	Decrease motor load. If no motor overload exists, check the temperature model parameters.
17	160	Motor underload	Motor is underloaded.	Check load.
19	180	Power overload (short-time supervision)	Drive power is too high.	Decrease load.
	181	Power overload (long-time supervision)		

Fault code	Fault ID	Fault name	Possible cause	Remedy
25		Motor control fault	Start angle identification has failed. Generic motor control fault.	
32	312	Fan cooling	Fan life time is up.	Change fan and reset fan life time counter.
33		Fire mode enabled	Fire mode of the drive is enabled. The drive's protections are not in use.	
37	360	Device changed (same type)	Option board changed for one previously inserted in the same slot. The board's parameter settings are saved.	Device is ready for use. Old parameter settings will be used.
38	370	Device changed (same type)	Option board added. The option board was previously inserted in the same slot. The board's parameter settings are saved.	Device is ready for use. Old parameter settings will be used.
39	380	Device removed	Option board removed from slot.	Device no longer available.
40	390	Device unknown	Unknown device connected (power unit/option board).	Device no longer available.
41	400	IGBT temperature	IGBT temperature (unit temperature + I ₂ T) is too high.	Check loading. Check motor size. Make identification run.
43	420	Encoder fault	Encoder 1 channel A is missing.	Check encoder connections. Check encoder and encoder cable. Check encoder board. Check encoder frequency in open loop.
	421		Encoder 1 channel B is missing.	
	422		Both encoder 1 channels are missing.	
	423		Encoder reversed.	
	424		Encoder board missing	
44	430	Device changed (different type)	Option board changed for one not present in the same slot before. No parameter settings are saved.	Set the option board parameters again.
45	440	Device changed (different type)	Option board added. The option board was not previously present in the same slot. No parameter settings are saved.	Set the option board parameters again.
51	1051	External fault	Digital input.	
52	1052 1352	Keypad communication fault	The connection between the control keypad and variable frequency drive is broken	Check keypad connection and possible keypad cable
53	1053	Fieldbus communication fault	The data connection between the fieldbus master and fieldbus board is broken	Check installation and fieldbus master.

Fault code	Fault ID	Fault name	Possible cause	Remedy
54	1354	Slot A fault	Defective option board or slot.	Check board and slot.
	1454	Slot B fault		
	1554	Slot C fault		
	1654	Slot D fault		
	1754	Slot E fault		
65	1065	PC communication fault	The data connection between the PC and variable frequency drive is broken.	
66	1066	Thermistor fault	The thermistor input has detected an increase of motor temperature.	Check motor cooling and load. Check thermistor connection (If thermistor input is not in use it has to be short circuited)
69	1310	Fieldbus mapping error	Non-existing ID number is used for mapping values to Fieldbus Process Data Out.	Check parameters in Fieldbus Data Mapping [→ 57] menu.
	1311		Not possible to convert one or more values for Fieldbus Process Data Out.	The value being mapped may be of undefined type. Check parameters in Fieldbus Data Mapping [→ 57] menu.
	1312		Overflow when mapping and converting values for Fieldbus Process Data Out (16-bit).	
101	1101	Process supervision fault (PID1)	PID controller: Feedback value outside of supervision limits (and the delay if set).	
105	1105	Process supervision fault (PID2)	PID controller: Feedback value outside of supervision limits (and delay, if set).	

Issued by
Siemens Industry, Inc.
Building Technologies Division
1000 Deerfield Pkwy
Buffalo Grove IL 60089
Tel. +1 847-215-1000

© 2013 Copyright Siemens Industry, Inc.
Technical specifications and availability subject to change without notice.