



SERIES DH3 | DIGIHELIC® DIFFERENTIAL PRESSURE CONTROLLER



Note: Shown with optional -SS bezel.
Backward compatible with Magnehelic® gage.

FEATURES/BENEFITS

- A low differential pressure gage, switch & transmitter combination instrument allows for local display, high/low alarm monitoring and connectivity to building automation systems
- Full scale accuracy of 1.5% or better even on extremely low ranges, and 0.5% for ranges above 5 in w.c. provide for greater measurement precision
- A reliable controller to measure low differential pressure, velocity or flow applications
- Secure menu program provides access to device operation only for the right skill level
- Optional stainless steel bezel is the same installation diameter as Magnehelic® gage and simplifies field upgrade to DH3 pressure controller

APPLICATIONS

- Cleanroom monitoring
- Filter status
- Duct or building static pressure
- Damper and fan control

DESCRIPTION

The **Series DH3 Digihelic® Differential Pressure Controller** is a 3-in-1 instrument possessing a digital display gage, control relay switches, and a transmitter with current output all packed in the popular Photohelic® gage style housing. Combining these 3 features allows the reduction of several instruments with one product, saving inventory, installation time and money. The Digihelic® controller is the ideal instrument for pressure, velocity and flow applications, achieving a 1% full scale accuracy on ranges down to the extremely low 0.25 in w.c. to 2.5 in w.c. full scale. Ranges of 5 in w.c. and greater maintain 0.5% FS accuracy. Bi-directional ranges are also available.

The Series DH3 Digihelic® controller allows the selection of pressure, velocity or volumetric flow operation in several commonly used engineering units. 2 SPDT control relays with adjustable deadbands are provided along with a scalable 4-20 mA process output.

Programming is easy using the menu key to access 5 simplified menus which provide access to: security level; selection of pressure, velocity or flow operation; selection of engineering units; K-factor for use with flow sensors; rectangular or circular duct for inputting area in flow applications; set point control or set point and alarm operation; alarm operation as a high, low or high/low alarm; automatic or manual alarm reset; alarm delay; view peak and valley process reading; digital damping for smoothing erratic process applications; scaling the 4-20 mA process output to fit your applications range and field calibration

SPECIFICATIONS

Service	Air and non-combustible, compatible gases.
Wetted Materials	Consult factory.
Housing Material	Die cast aluminum case and bezel.
Accuracy	±1.5% for 0.25 in and ±0.25 in w.c. ranges. Ranges 0.5 to 5 in w.c. and corresponding bi-directional (except ±2.5 in w.c.) ±1%; All other ranges: ±0.5% @ 77°F (25°C) including hysteresis and repeatability (after 1 hour warm-up).
Stability	< ±1% per year.
Pressure Limits	Ranges (uni- and corresponding bidirectional), ≤ 1 in w.c.: 9 psi; 2.5 and 5 in w.c.: 1.5 psi; 10 in w.c.: 3 psi; 25 in w.c.: 8 psi; 50 in w.c.: 15 psi; 100 in w.c.: 20 psi.
Temperature Limits	32 to 140°F (0 to 60°C).
Compensated Temperature Limits	32 to 140°F (0 to 60°C).
Thermal Effects	0.020%/°F (0.036/°C) from 77°F (25°C). For 0.25 in and ±0.25 in w.c. ranges: ±0.03%/°F (±0.054%/°C).
Power Requirements	12-28 VDC, 12-28 VAC 50 to 400 Hz.
Power Consumption	3 VA max.
Output Signal	4-20 mA DC into 900 Ω max.
Zero & Span Adjustments	Accessible via menus.
Response Time	250 ms (damping set to 1).
Display	Backlit 4 digit LCD 0.4" height LED indicators for set point and alarm status.
Electrical Connections	15 pin male high density D-sub connection. 18" (46 cm) cable with 10 conductors included.
Process Connections	1/8" female NPT. Side or back connections.
Mounting Orientation	Mount unit in vertical plane.
Size	5" (127 mm) OD x 3-1/8" (79.38 mm). For -SS Bezel 4-3/4" OD (120.7 mm) x 2-21/32" (67.5 mm).
Weight	1.75 lb (794 g).
Agency Approvals	CE.

SWITCH SPECIFICATIONS

Switch Type	2 SPDT relays.
Electrical Rating	1 A @ 30 VAC/VDC.
Set Point Adjustment	Adjustable via keypad on face.

DIMENSIONS

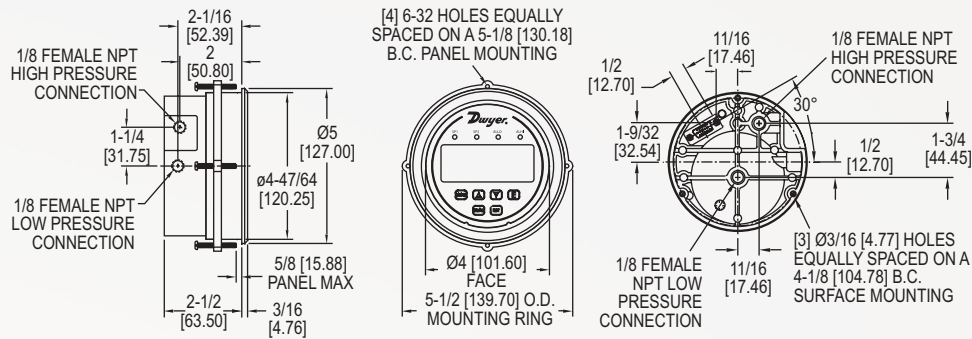

HOW TO ORDER

Use the **bold** characters from the chart below to construct a product code.

SERIES	DH3	-004	-SS	
DH3 - Digihelic® differential pressure controller				
RANGE				OPTIONS
002: 0 to 0.25 in w.c.		011: 0 to 100 in w.c.		AT: Aluminum tag
003: 0 to 0.5 in w.c.		013: 0 to ±0.25 in w.c.		COO: Certificate of origin
004: 0 to 1 in w.c.		014: 0 to ±0.50 in w.c.		FC: Factory calibration
005: 0 to 2.5 in w.c.		015: 0 to ±1.00 in w.c.		NIST: NIST traceable calibration certificate
006: 0 to 5 in w.c.		016: 0 to ±2.50 in w.c.		SS: Brushed 304 stainless steel bezel
007: 0 to 10 in w.c.		017: 0 to ±5.00 in w.c.		ST: Stainless steel tag
009: 0 to 25 in w.c.		018: 0 to ±10.0 in w.c.		
010: 0 to 50 in w.c.				

ACCESSORIES

Model	Description
A-298	Flat aluminum bracket for flush mounting
A-301	Static pressure tip, for 1/4" metal tubing connection
A-302	Static pressure tip, for 3/16" and 1/8" ID plastic or rubber tubing
A-302F-A	303 SS Static pressure tip with mounting flange, for 3/16" I.D. rubber or plastic tubing. 4" insertion depth, includes mounting screws
A-370	Flush mount bracket. Bracket is then surface mounted. Steel with gray hammertone epoxy finish
A-489	4" 303 SS straight static pressure tip with flange

ORDER ONLINE TODAY!

dwyer-inst.com/Product/SeriesDH3



DWYER INSTRUMENTS, INC.

©Copyright 2020 Dwyer Instruments, Inc.
Printed in U.S.A. 5/20

DS-DH3 Rev. 2

Important Notice: Dwyer Instruments, Inc. reserves the right to make changes to or discontinue any product or service identified in this publication without notice. Dwyer advises its customers to obtain the latest version of the relevant information to verify, before placing any orders, that the information being relied upon is current.