

G765-250 Technical Data Sheet

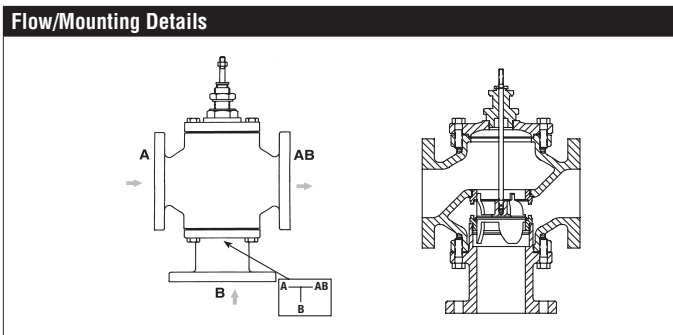

Technical Data	
Fluid	chilled, hot water, up to 60% glycol
Flow characteristic	linear
Controllable flow range	stem up - open B – AB
Valve Size [mm]	2.5" [65]
Pipe connection	250 lb flanged
Housing	Cast iron - ASTM A126 Class B
Stem	stainless steel
Stem seal	NLP EPDM (no lip packing)
Seat	Stainless steel AISI 316
Valve plug	bronze
Body Pressure Rating	ANSI Class 250, up to 280 psi below 350°F
ANSI Class	250
Number of Bolt Holes	8
Rangeability Sv	50:1
Cv	68
Weight	70.56 lb [32 kg]
Fluid Temp Range (water)	32...350°F [0...176°C]
Leakage rate	ANSI Class III
Servicing	repack/rebuild kits available



Application

This valve is typically used in large air handling units on heating or cooling coils. This valve is suitable for use in a hydronic system with variable flow. Valves are designed for ANSI 250 piping systems

Suitable Actuators

	Non-Spring	Spring	Electronic fail-safe
G765-250	EVB(X), RVB(X)	AF, 2*AFB(X)	AVKB(X), 2*GKB(X)

Dimensions (Inches [mm])

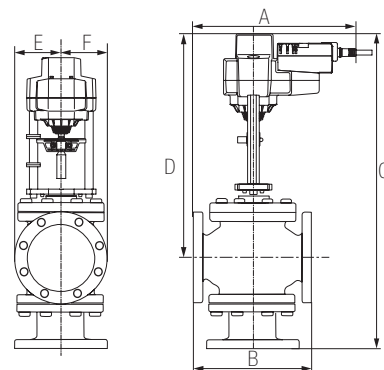

EVB, EVX, RVB, RVX

A	B	C	D	E	F
12.0" [304]	9.6" [245]	25.4" [646]	18.3" [464]	3.7" [95]	

Safety Notes

WARNING: This product can expose you to lead which is known to the State of California to cause cancer and reproductive harm. For more information go to www.p65warnings.ca.gov

Piping

The valves should be mounted in a weather-protected area in a location that is within the ambient limits of the actuator. Allow sufficient room for valve with actuator and for service. The preferred mounting position of the valve is with the valve stem vertical above the valve body, for maximum life. However, the assemblies can be mounted with valve stem vertical above the valve or up to 45° in relation to the horizontal pipe. The actuators should never be mounted underneath the valve, as condensation can build up and result in a failure of the actuators. Do not reverse flow direction.

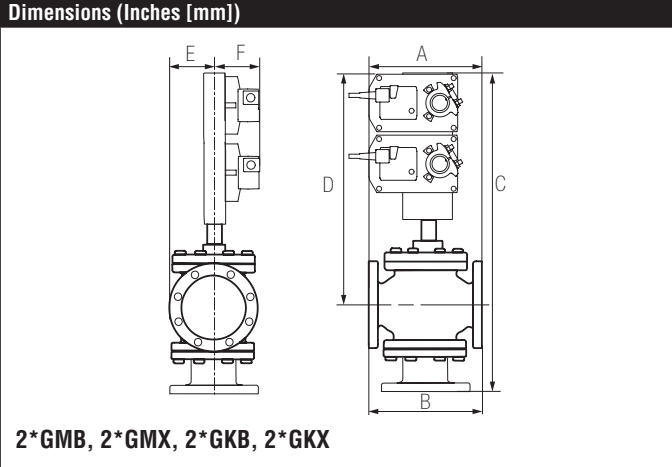

A	B	C	D	E	F
12.0" [304]	9.6" [245]	29.0" [736]	21.8" [554]	3.7" [95]	5.3" [135]

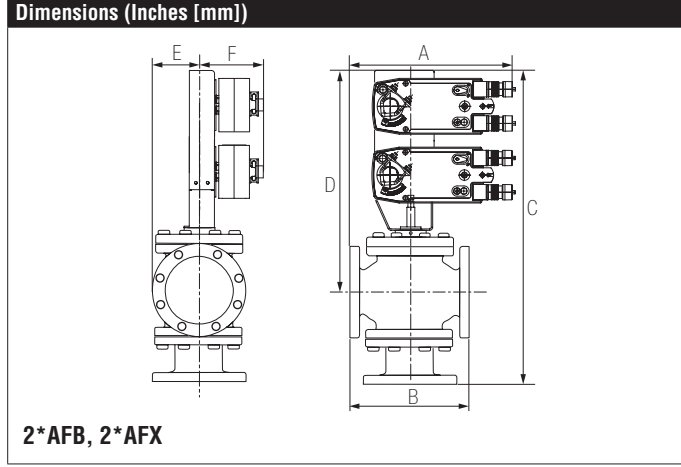

A	B	C	D	E	F
12.0" [304]	9.6" [245]	29.0" [736]	21.8" [554]	3.7" [95]	5.3" [135]

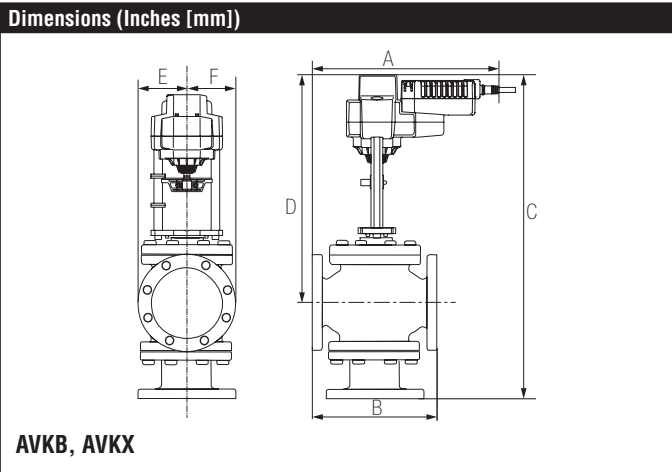

A	B	C	D	E	F
12.0" [304]	9.6" [245]	25.4" [646]	18.3" [464]	3.7" [95]	

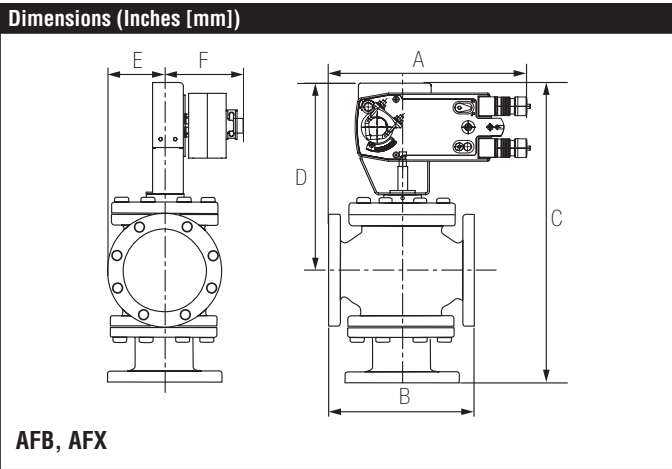

A	B	C	D	E	F
12.0" [304]	9.6" [245]	24.0" [610]	16.9" [428]	3.7" [95]	5.3" [135]

RVB24-MFT Technical Data Sheet

Modulating, Non-Spring Return, Linear, 24 V, Multi-Function Technology®



5-year warranty



Technical Data	
Power Supply	24 VAC, ±20%, 50/60 Hz, 24 VDC, ±10%
Power consumption in operation	6 W
Power consumption in rest position	1.5 W
Transformer sizing	11 VA (class 2 power source)
Electrical Connection	18 GA plenum cable, 3 ft [1 m], with 1/2" conduit connector, degree of protection NEMA 2 / IP54
Overload Protection	electronic throughout full stroke
Electrical Protection	actuators are double insulated
Operating Range	DC 2...10 V (default), 4...20 mA w/ ZG-R01 (500 Ω, 1/4 W resistor), variable (VDC, on/off, floating point)
Operating range Y variable	Start point DC 0.5...30 V End point DC 2.5...32 V
Input Impedance	100 kΩ for DC 2...10 V (0.1 mA), 500 Ω for 4...20 mA, 1500 Ω for On/Off
Position Feedback	DC 2...10 V
Stroke	0.75" [19 mm]
Actuating force motor	1010 lbf [4500 N]
Direction of rotation motor	reversible with switch
Position indication	Mechanically, with pointer
Manual override	5 mm hex crank (3/16" Allen), supplied
Running Time (Motor)	90 s, constant, independent of load
Ambient humidity	max. 95% r.H., non-condensing
Ambient temperature	-22...122°F [-30...50°C]
Storage temperature	-40...176°F [-40...80°C]
Degree of Protection	IP54, NEMA 2, UL Enclosure Type 2
Housing material	Die cast aluminium and plastic casing
Agency Listing	cULus acc. to UL60730-1A/-2-14, CAN/CSA E60730-1:02, CE acc. to 2004/108/EC and 2006/95/EC
Noise level, motor	65 dB(A)
Maintenance	maintenance-free
Quality Standard	ISO 9001
Weight	9.02 lb [4.1 kg]

Safety Notes

WARNING: For Belimo products sold in California: these products do or may contain chemicals which are known to the State of California to cause cancer and or birth defects or other reproductive harms. For more information see www.p65warnings.ca.gov.

Date created, 09/11/2019 - Subject to change. © Belimo Aircontrols (USA), Inc.

† Use flexible metal conduit. Push the listed conduit fitting device over the actuator's cable to butt against the enclosure. Screw in conduit connector. Jacket the actuators input wiring with listed flexible conduit. Properly terminate the conduit in a suitable junction box. Rated impulse Voltage 800V. Type of action 1. Control pollution degree 3.

Wiring Diagrams

INSTALLATION NOTES

- Actuators may be connected in parallel. Power consumption and input impedance must be observed.
- Actuators may also be powered by 24 VDC.
- A 500 Ω resistor (ZG-R01) converts the 4 to 20 mA control signal to 2 to 10 VDC.
- Control signal may be pulsed from either the Hot (Source) or Common (Sink) 24 VAC line.
- For triac sink the common connection from the actuator must be connected to the hot connection of the controller. Contact closures A & B also can be triacs. A & B should both be closed for the triac source and open for triac sink.
- Actuators with plenum cable do not have numbers; use color codes instead.
- Meets cULus requirements without the need of an electrical ground connection.
- WARNING! LIVE ELECTRICAL COMPONENTS!** During installation, testing, servicing and troubleshooting of this product, it may be necessary to work with live electrical components. Have a qualified licensed electrician or other individual who has been properly trained in handling live electrical components perform these tasks. Failure to follow all electrical safety precautions when exposed to live electrical components could result in death or serious injury.

