

The Advanced Pressure Monitor II (APM2) is a flexible, touch-screen local display unit that measures pressure, temperature, and humidity for pressurized spaces for the purpose of ensuring integrity of ventilation and airflow. The APM2 is more than a pressure monitor. Flexible use of analog inputs allows temperature and humidity sensors to be configured for these additional values to be displayed for the user. A digital output can also be used for local occupancy control of an airflow control valve or other two-state device.

The APM2 provides a bright, easy-to-read display that combines a free-form message banner on the left one-third of the screen, together with dynamic room operating parameters on the right two-thirds of the screen. The touch-screen display makes the APM2 easy to operate by just pressing areas of the screen to perform functions. Nuisance alarms are virtually eliminated because of the high accuracy and reliability of the APM2, and through the use of seven types of alarm functions. If desired, the APM2 can be configured so it never needs to be touched by staff on the floor.

FREE-FORM MESSAGE BANNER

Having only the value of a pressure reading on a display is not always meaningful to untrained staff. To address this, the left one-third of the screen is dedicated to a free-form message banner that is intended to provide notice to personnel outside the room what is happening inside the room. The conditions are red for "stop", yellow for "caution", and green or blue for "go". Text above and below the color icon can be customized by the user, and made full screen if desired. Each of the four colors can be assigned functions: room occupied, room unoccupied, APM2 is active, APM2 is in standby, or no action.

The right two-thirds of the screen shows the room label, intended pressure (positive, negative, neutral), operation (normal, alarm, door, valve), the pressure value (WC or Pa) and a slide-bar that indicates where the current pressure reading is relative to alarm setpoints.

ACCURACY

Using pressure transducer technology, the APM2 is capable of sensing at a 0.5% ($\pm 0.25\%$) full scale accuracy and with a display resolution up to 0.0001" WC. It can meet the stringent requirements of pressure sensing for laboratory animal facilities, critical healthcare spaces, biocontainment cleanrooms and any application where very low room pressure sensing is required.



FEATURES

- 4.3" Color touch-screen TFT display
- Monitor two spaces with one APM2 (option)
- One-touch room mode change
- Message banner informs staff of room condition
- Two levels of password protection
- Visual/audible local or remote alarming
- Valve flow alarming
- Door status indicator
- Positive, negative, or neutral setpoints
- French language support
- Mode switches alarm setpoints for positive, negative or neutral rooms
- Resistant to spray washdown (IP-54)
- Resistant to decontamination chemicals
- Mounts in standard off-the-shelf electrical box
- Clone configuration feature



NOTE: If the equipment is used in a manner not specified, the protection provided by the equipment may be impaired.

TABLE OF CONTENTS

Specifications	2
Ordering Guide	4
Applications	5
Installation	7
Dimensions	8
Phoenix Controls Wiring Recommendations ...	9
Maintenance	9
Ancillary Product Specifications	10
Phoenix Recommended Cables	16

SPECIFICATIONS

Choice of Full Scale Ranges			Environmental Data	
Bi-Directional	$\pm 0.05''$ WC (± 12.45 Pa) $\pm 0.10''$ WC (± 24.90 Pa) $\pm 0.25''$ WC (± 62.27 Pa) $\pm 0.50''$ WC (± 124.54 Pa) $\pm 1.00''$ WC (± 249.08 Pa)		Temperature Operating ³ °F (°C) 32 to +120 (0 to +50) Storage °F (°C) -20 to +160 (-30 to +70)	
Performance Data			Operating Humidity	5 to 95 % RH (non-condensing)
	Standard Accuracy	High Accuracy	Pressure Media	Air, or non-conductive non-explosive gasses
Accuracy RSS ^{1, 2} (at constant temp)	$\pm 0.5\%$ FS	$\pm 0.25\%$ FS	Altitude	6562 ft. (2000 m) max.
Non-linearity (BFSL-based)	$\pm 0.49\%$ FS	$\pm 0.24\%$ FS	Physical Description	
Hysteresis	$\pm 0.05\%$ FS	$\pm 0.05\%$ FS	Display	4.3" touch-screen TFT LCD, 480 x 272 pixels, dimmable, password protected
Non-repeatability	$\pm 0.05\%$ FS	$\pm 0.05\%$ FS	Faceplate and housing	Fire-retardant plastic (UL94V-0)
Zero setting tolerance	$\pm 0.5\%$ FS	$\pm 0.5\%$ FS	Electrical connections	Removable terminal blocks
Span setting tolerance	$\pm 0.5\%$ FS	$\pm 0.5\%$ FS	Pressure fittings	Barbed fittings for ¼" flexible tubing
Stability per year	$\pm 1.0\%$ FS		Weight	1 lb. 3 oz. (590 grams)
Overpressure	15.00" WC (0.5 PSI)		Relay Type	SPDT
Thermal Effects¹			Relay Contact Rating	0.6A @125 Vac / 2A @ 30 Vdc
Zero	$\pm 0.03\%$ FS/°F ($\pm 0.05\%$ FS/°C)		Mains Supply Voltage	
Span	$\pm 0.03\%$ FS/°F ($\pm 0.05\%$ FS/°C)		Not to exceed 18-32 Vac, 50-60 Hz, isolated, resettable fuse, 9.6 VA maximum. Mains supply voltage fluctuations up to $\pm 10\%$	
Mounting			Interoperability	
Rough-in electrical box	RACO 697, Appleton M3-350		No communication	
Position	Housing to be 90° in reference to level surface, $\pm 5^\circ$			
Wire				
Power	2 or 3-conductor (depending on application) stranded unshielded twisted pair, 16-22 AWG			
I/O	Stranded shielded twisted pair, Belden 950x, 16-28 AWG			
Communications - 3-conductor, twisted, shielded 22 AWG cable (See "Phoenix Recommended Cables" on page 17.)				
Inputs				
AI-1, AI-2	Analog Inputs. Multi-purpose, choose a function: - Function 1: Primary or secondary room input - Function 2: Tri-state input to switch pressure alarm thresholds 0 Vdc = Space is intended to be negative pressure. Alarm threshold values are placed in the negative range. 5 Vdc = Space is intended to be neutral pressure. Alarms are placed in the span zero neutral range. 10 Vdc = Space is intended to be positive pressure. Alarms threshold values are placed in the positive range. - Function 3: Temperature or humidity sensor (voltage output either 0-5 V or 0-10 V).			

DI-1	Digital Input, door status indicator or valve pressure switch indicator (choose one). Door status: visual on LCD, yellow on door open Dry contact Closed = Door closed or no valve alarm; Open = Door open or valve alarm Configurable, door open can disable alarming
Outputs	
AO-1	Analog Output. Filtered output signal of primary room pressure differential. Field selectable: 0-5 Vdc; 0-10 Vdc; or 4-20 mA. Speed of response = 100 ms Max., 3 time constants
DO-1	Digital Output. SPDT alarm relay to remote annunciator or the relay can be used for occupancy contact with message banner (choose one) Alarm deadband 0—10% of setpoint adjustable Contact rating 2.0A @ 30 Vdc/Vac, 0.6A @ 125 Vac Calibrated into a 50K Ω load, operable into a 5K Ω load or greater
Alarming	
Ranges	Positive, negative or spanning zero pressure (across neutral)
Audible	Dual piezo with 4 volume levels, (from 0—75dB)
Visual	LCD display Red = Alarm, Yellow = Warning, or Green = Normal, Backlight = 4 levels
Remote	Annunciation via Digital Output SPDT relay
Latch	Alarm must be acknowledged at the touch-screen and pressure must return within range
Silence	Selectable 0-9999 (9999 = forever) seconds
Delay	Selectable 0-9999 (9999 = forever) seconds
Valve	Flow alarm notification
BACnet	Alarm and event notification services
Display Parameters	
Temperature — °F or °C Pressure — "WC or Pa Humidity — %RH	
USB Port	
A mini-USB style port is provided for firmware updates or for copying configurations from one monitor to others that require similar parameters (i.e., cloning). Phoenix Controls REQUIRES either the Kingston DataTraveler 112 4GB flash drive or Sandisk Cruzer 2GB (minimum) flash drive, along with the aid of a short mini-USB adapter cable from Tensility Corporation (P/N 10-00003). No PC is required.	
Washdown and Chemical Resistance	
IP-54 rated against dust and liquid penetration. Exposed surfaces are chemically resistant to vaporized hydrogen peroxide (VHP), formaldehyde, chlorine dioxide (clidox), perchloric acid, sodium hypochlorite 3-6% (bleach), quaternary ammonium 7% in 1:128 tap water (ammonia).	
Regulatory Compliance	
CE, CSA, RoHS, WEEE, Electro Magnetic Compatibility Directive 2004/108/EC  	
¹ Units calibrated at nominal 70°F. Maximum thermal error computed from this datum. ² RSS is root sum of squares of non-linearity (BFSL), non-repeatability, and hysteresis. ³ Operating temperature limits of electronics only, not pressure transducer.	

ORDERING GUIDE

MONITORS

APM2 00 - ENG - ANU - STL

PRODUCT FAMILY

APM2 = Advanced Pressure Monitor II, comes standard with white faceplate and two pressure pickup ports.

OPERATIONAL PRESSURE RANGE

00 = ±0.05" WC (12.45 Pa) (±0.5% accuracy)
01 = ±0.10" WC (24.90 Pa) (±0.5% accuracy)
03 = ±0.25" WC (62.27 Pa) (±0.5% accuracy)
05 = ±0.50" WC (124.54 Pa) (±0.5% accuracy)
10 = ±1.00" WC (249.08 Pa) (±0.5% accuracy)
30 = ±0.05" WC (12.45 Pa) (±0.25% accuracy)
31 = ±0.10" WC (24.90 Pa) (±0.25% accuracy)
33 = ±0.25" WC (62.27 Pa) (±0.25% accuracy)
35 = ±0.50" WC (124.54 Pa) (±0.25% accuracy)
40 = ±1.00" WC (249.08 Pa) (±0.25% accuracy)

FACEPLATE LANGUAGE

ENG = English

NETWORK TYPE

ANU = Analog (firmware can be upgraded)

OPTIONS

NPP = No pressure ports, APM2XX is provided without the two standard pressure pickup ports
RET = Retrofit kit; includes modified APM2xx with 90 degree ports and faceplate that covers hole from APM1xx and excludes the two pressure pick-up ports that come standard with non-retrofit units. (see Note)
STL = Simulated brushed steel faceplate (No extra charge)

NOTE: Cannot be ordered with ±0.25 accuracy pressure range APM2xx, nor with options "NPP" or "STL"
 Calibration certificates are provided with all products except ±1.00% accuracy

Accessories

APM2 AC - F01

PRODUCT FAMILY

APM2 = Advanced Pressure Monitor II

PRODUCT OPTION

AC = Accessory

TYPE

ANC = Remote annunciator sounds an audible alarm; remote unit is located away from the wall-mounted unit housed in a single-gang stainless steel wall plate; includes a remote alarm speaker and remote acknowledge button to temporarily silence the alarm.
PPP = Pressure Pickup Port, an additional single-gang stainless steel plate used to sense room pressure - two PPPs are included standard with the APM2.

For all of the following transducers:

Remote pressure transducers can be used with the APM2 to measure differential pressure in a secondary space. The 264 and 267 transducers sense differential pressure and convert this pressure difference to a proportional electrical output signal - either 0-5 Vdc or 0-10 Vdc, respectively. Using 0-10 Vdc (267 model) provides a higher resolution output signal than 0-5 Vdc (264 model). Standard accuracy is usually adequate for most critical room applications. Use high accuracy if building specifications require it.

F00 = 264 transducer, 0-5V output, ±0.05" WC (12.45 Pa) (±1.00% accuracy)
F01 = 264 transducer, 0-5V output, ±0.10" WC (24.90 Pa) (±1.00% accuracy)
F03 = 264 transducer, 0-5V output, ±0.25" WC (62.27 Pa) (±1.00% accuracy)
F05 = 264 transducer, 0-5V output, ±0.50" WC (124.54 Pa) (±1.00% accuracy)
F10 = 264 transducer, 0-5V output, ±1.00" WC (249.08 Pa) (±1.00% accuracy)
F20 = 264 transducer, 0-5V output, ±0.05" WC (12.45 Pa) (±0.40% accuracy)
F21 = 264 transducer, 0-5V output, ±0.10" WC (24.90 Pa) (±0.40% accuracy)
F23 = 264 transducer, 0-5V output, ±0.25" WC (62.27 Pa) (±0.40% accuracy)
F25 = 264 transducer, 0-5V output, ±0.50" WC (124.54 Pa) (±0.40% accuracy)
F30 = 264 transducer, 0-5V output, ±1.00" WC (249.08 Pa) (±0.40% accuracy)
F40 = 264 transducer, 0-5V output, ±0.05" WC (12.45 Pa) (±.25% accuracy)
F41 = 264 transducer, 0-5V output, ±0.10" WC (24.90 Pa) (±.25% accuracy)
F43 = 264 transducer, 0-5V output, ±0.25" WC (62.27 Pa) (±.25% accuracy)
F45 = 264 transducer, 0-5V output, ±0.50" WC (124.54 Pa) (±.25% accuracy)
F50 = 264 transducer, 0-5V output, ±1.00" WC (249.08 Pa) (±.25% accuracy)
T00 = 267 transducer, 0-10V output, ±0.05" WC (12.45 Pa) (±1.00% accuracy)
T01 = 267 transducer, 0-10V output, ±0.10" WC (24.90 Pa) (±1.00% accuracy)
T03 = 267 transducer, 0-10V output, ±0.25" WC (62.27 Pa) (±1.00% accuracy)
T05 = 267 transducer, 0-10V output, ±0.50" WC (124.54 Pa) (±1.00% accuracy)
T10 = 267 transducer, 0-10V output, ±1.00" WC (249.08 Pa) (±1.00% accuracy)
T20 = 267 transducer, 0-10V output, ±0.05" WC (12.45 Pa) (±0.40% accuracy)
T21 = 267 transducer, 0-10V output, ±0.10" WC (24.90 Pa) (±0.40% accuracy)
T23 = 267 transducer, 0-10V output, ±0.25" WC (62.27 Pa) (±0.40% accuracy)
T25 = 267 transducer, 0-10V output, ±0.50" WC (124.54 Pa) (±0.40% accuracy)
T30 = 267 transducer, 0-10V output, ±1.00" WC (249.08 Pa) (±0.40% accuracy)
T40 = 267 transducer, 0-10V output, ±0.05" WC (12.45 Pa) (±.25% accuracy)
T43 = 267 transducer, 0-10V output, ±0.10" WC (24.90 Pa) (±.25% accuracy)
T44 = 267 transducer, 0-10V output, ±0.25" WC (62.27 Pa) (±.25% accuracy)
T45 = 267 transducer, 0-10V output, ±0.50" WC (124.54 Pa) (±.25% accuracy)
T50 = 267 transducer, 0-10V output, ±1.00" WC (249.08 Pa) (±.25% accuracy)

APPLICATIONS

The Advanced Pressure Monitor may be applied in many ways. Four examples are given below:

1. VAV Room with Occupied and Unoccupied Modes

VAV valves control supply and exhaust as a tracking pair, creating a pressurized space. The Message Banner is configured for specific colors to indicate Occupied and Unoccupied mode for the room. When the Occupied color is selected, the DO-1 relay CLOSES and the supply valve controller modifies airflow and temperature for the Occupied setting. When the Unoccupied color is selected, the DO-1 relay OPENS and the supply valve controller modifies airflow and temperature for the Unoccupied setting.

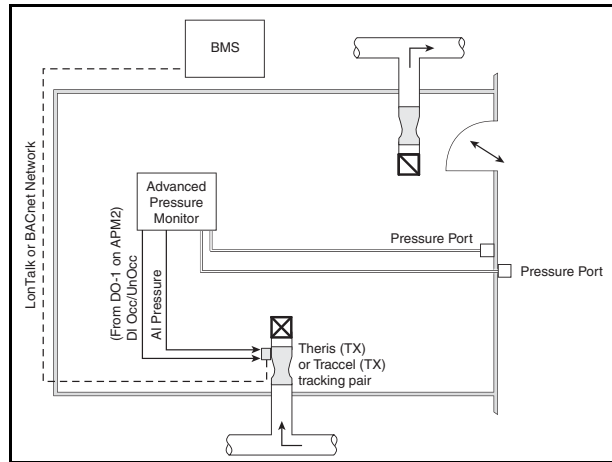

Figure 1. Simple constant volume room application

2. Switchable Positive and Negative Room with Reversible Alarm Setpoint and Flow Alarm

Variable air volume (VAV) valves control supply and exhaust as a tracking pair, creating a pressurized space that is either positive or negative. APM2 pressure alarm setpoints are defined for both positive and negative ranges (see Figure 2). When the room is negative, negative alarm setpoints are active. When the room is positive, positive alarm setpoints are active. A tri-state input to the APM2 switches the mode and setpoints: 0 Vdc = negative, 5 Vdc = neutral, and 10 Vdc = positive. A network signal from the BMS changes the airflow offset from positive to negative. The tracking pair of valves fitted with pressure switches provide a flow alarm input to the APM2, which is shown on the display in red as a VALVE alarm.

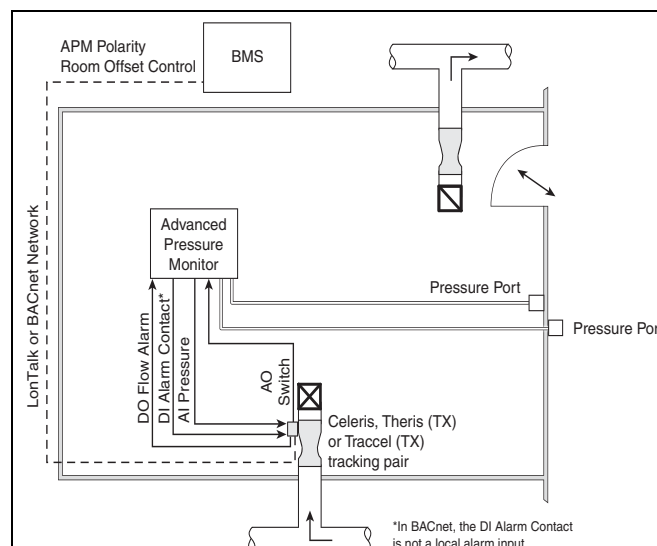

Figure 2. Switchable positive and negative room with reversible alarm setpoint and flow alarm application

3. Primary Room with Anteroom

Variable air volume (VAV) valves control supply and exhaust as a tracking pair, creating two pressurized spaces that are both negative to their respective references. A secondary differential pressure signal (remote sensor accessory) is provided to the APM2. The APM2 display shows both room conditions, toggling the display between the primary room and anteroom (see Figure 3). Both spaces can be configured to alarm independently. A door contact is also connected to the APM2. If the door is open, the display indicates DOOR in yellow.

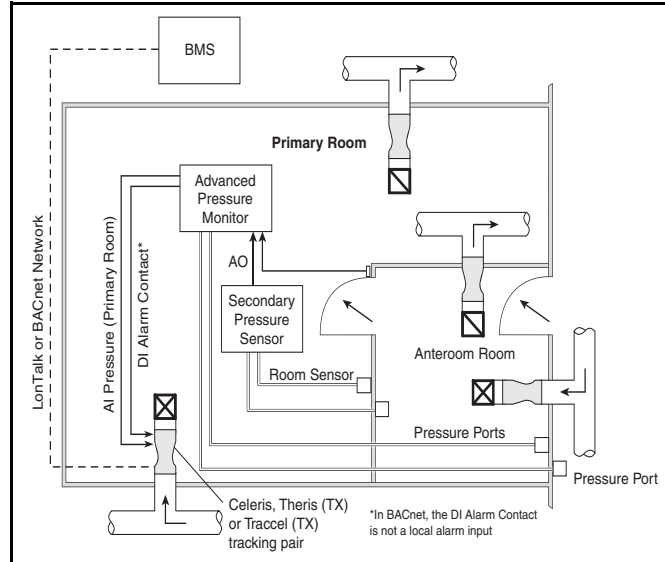

Figure 3. Primary room with anteroom application

4. Pressure Control Using Progressive Offset Control (POC)

In certain applications, active pressure control is desired. To achieve this, Phoenix Controls uses a control feature on Celeris valves called Progressive Offset Control, or POC. POC builds on the principle of volumetric offset by adding a differential pressure control algorithm that trims the offset to maintain a desired room pressure. The APM2 uses its high-speed analog output to feed a differential pressure signal to the Celeris valve controller (see Figure 4). The POC function then responds quickly to maintain directional airflow when a door to the pressurized space opens, and recovers quickly once the door closes.

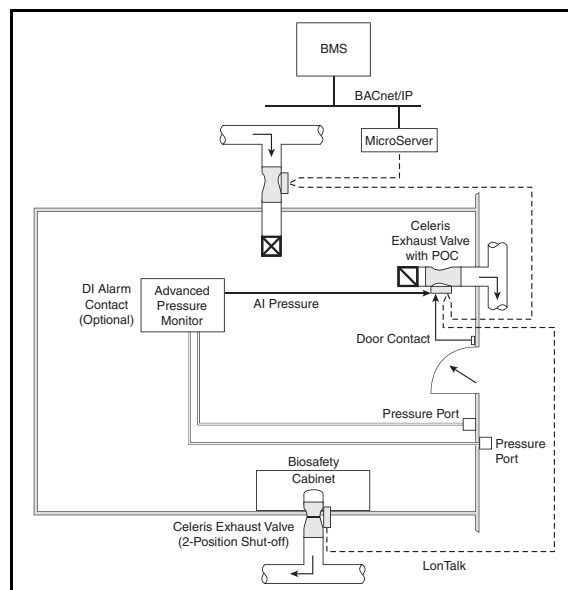

Figure 4. Pressure control using Progressive Offset Control (POC) application

INSTALLATION

Installation must be indoors, Pollution Degree 2, Installation category II.

- Each APM2 consists of a room pressure pick-up, a reference space pressure pickup and a room pressure monitor panel, which houses a differential pressure sensor.
- The two pressure pickup ports are installed in single gang electrical boxes, which are placed in the room walls.
- Standard 0.25" (6 mm) control tubing, maximum 250 feet (76.2 meters) length, is run within the wall from the sensors to the monitor panel. In some code jurisdictions, the tubing must be in EMT conduit. Tubing and conduit is provided by others.
- Install in a triple gang-double deep electrical box (RACO 697, Appleton M3-350 or equivalent).

NOTE: Secure the triple gang-double deep electrical box to the stud(s) by using the mounting hole in the side of the electrical box (see figure below for mounting hole location). Drive the mounting screws from the inside of the electrical box into the wall studs to prevent sharp objects protruding into the electrical box.

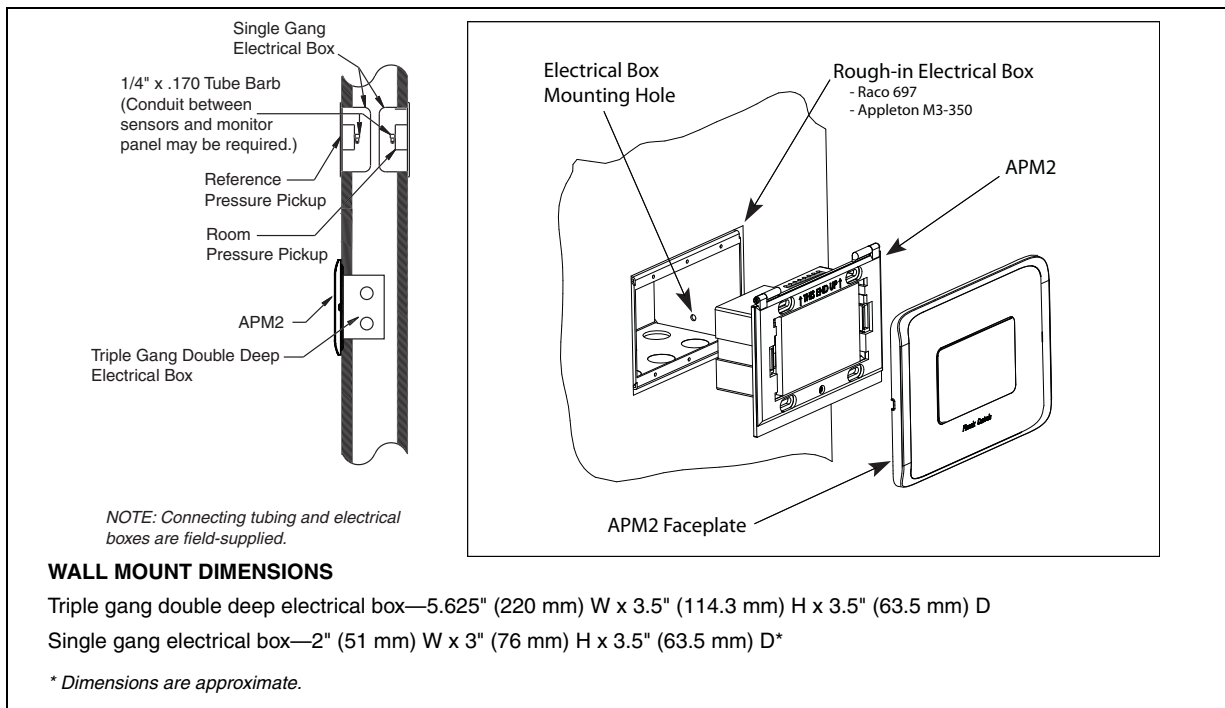

Faceplate

The faceplate of the APM2 is designed to snap-fit the unit and seal to the display and wall surface to resist the penetration of cleaning agents and dust (IP54). Available options are white or a simulated brushed stainless steel.



DIMENSIONS

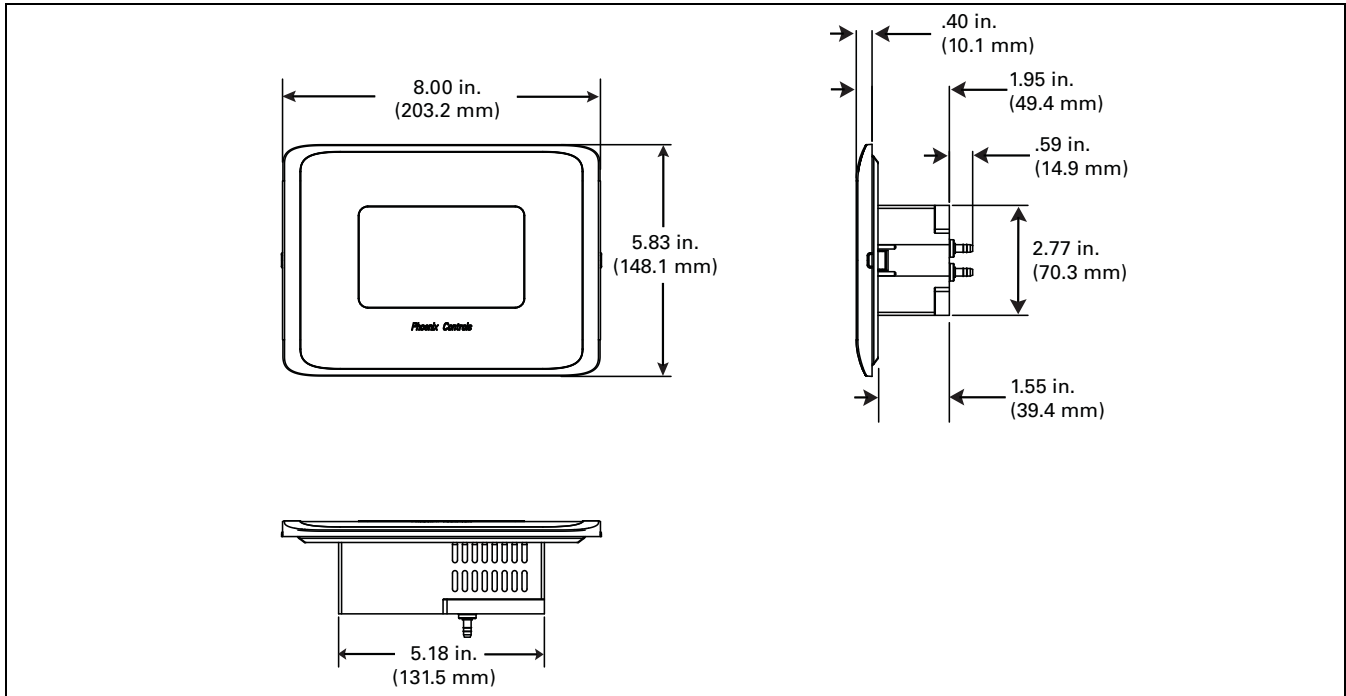

WIRING

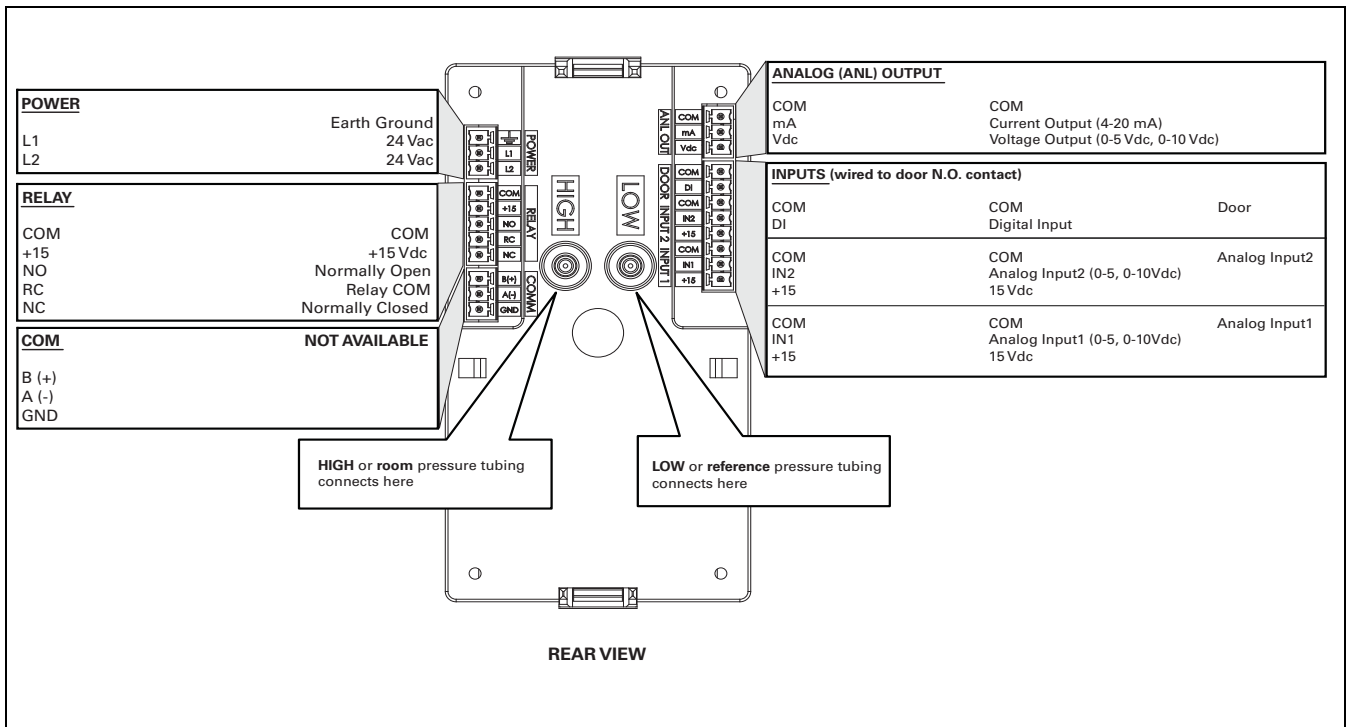

PHOENIX CONTROLS WIRING RECOMMENDATIONS

- All circuits must conform to the requirements of an NEC Class 2 (dry) circuit.
- Use multiple transformers instead of larger transformers when more than 100 VA is required.
- Each pressurization zone should have either a dedicated single-phase primary circuit, or a secondary circuit disconnect.
- Use cable sizes recommended by Phoenix Controls (See “Phoenix Recommended Cables” on page 17,).
- Use stranded wire for ease of installation.
- Follow good wiring practices:
 - Locate cables away from sources of electrical interference (EMI/RFI).
 - Do not run signal or communication cable in the same conduit or wire way as power cables.
 - If signal cable must cross power cables place these at a 90-degree angle.
 - Shield or drain wires, if required, should be wrapped with insulating tape to prevent contact with exposed conductors or contacts.
 - Maintain a consistent color code or polarity all the way through the wiring system.
 - Power supply and signal isolation on I/O devices vary from manufacturer to manufacturer. Verify the wiring device manufacturer’s recommendations for isolating power and signal common connections and maintain polarity.
 - Local and national electrical codes take precedence.
- Strip 0.25" (6.4 mm) of insulation from each conductor, twist the strands, insert the conductor fully into the terminal block, and tighten the terminal.
 - Test the wire connection by pulling on each conductor.
- See “Ancillary Product Specifications” on page 10, for approved cable manufacturers and wire types.

MAINTENANCE

The APM2 requires no ongoing preventative maintenance. Once the field engineer has completed the field start-up, the monitor will provide years of continuous operation. If calibration is required to verify accuracy of measurement, field calibration can be done using a calibration device such as a Setra Micro-Cal Model 869. Field calibration should be done by properly trained personnel.

Cleaning

Do not blow into the pressure tubing or fittings with mouth, compressed air or canned air. Such actions may permanently damage the pressure sensor. Do not clean or wash-down the APM2 with industrial cleaners or solvents. The housing may be wiped down with soap and water or isopropyl alcohol. The LCD may only be cleaned with isopropyl alcohol. Do not immerse unit.

AGENCY ELECTRICAL STANDARDS

This device falls into CSA "Pollution Degree 2" for PCB Installation and CSA "Installation Category 2".

This APM2 meets the following requirements:

- **CSA Standard C22.2 No. 0-M 91:** General Requirements - Canadian Electrical Code, Part 1
- **CAN/CSA C22.2 No. 0.4-04:** Bonding of Electrical Equipment
- **CAN/CSA C22.2 No. 61010-1-04:** Safety requirements for electrical equipment for measurement, control and laboratory Use Part-1: General Requirements
- **ANSI/UL61010-1 (Special Edition):** Safety requirements for electrical equipment for measurement, control and laboratory Use Part-1: General Requirements

ANCILLARY PRODUCT SPECIFICATIONS

NOTE: The following specifications are subject to changes without notice.

Model 264 Pressure Transducer (Remote Transducer 0-5 V Output)

Model 264 Pressure Transducer			
Performance Data			
	Standard Accuracy	Mid-Range Accuracy	High Accuracy
	± 1.0 % FS	± 0.4 % FS	± 0.25 % FS
Non-linearity (BFSL)	± 0.96 % FS	± 0.38 % FS	± 0.22 % FS
Hysteresis	0.10% FS	± 0.10 % FS	0.10% FS
Non-repeatability	0.05% FS	± 0.05 % FS	0.05% FS
Thermal Effects ²			
Compensated Range °F (°C)	0 - 150 (-18 - 65)		
Zero/Span Shift % FS/°F (°C)	0.033 (0.06)		
Maximum Line Pressure	10 psi		
Overpressure	Up to 10 psi (range dependent)		
Long-term Stability	0.5% FS / year		
Position Effect	Range	Zero Offset (% FS/G)	
Unit is factory calibrated at 0g effect in the vertical position	To 0.5" WC	0.60	
	To 1.0" WC	0.50	
Environmental Data			
Temperature			
Operating ³ °F (°C)	0 - +175 (-18 - +79)		
Storage °F (°C)	-65 - +250 (-54 - +121)		
Physical Description			
Case	Fire-retardant glass filled polyster (UL94 V-0 Approved)		
Dimensions	2.75" (69.85 mm) W x 5.062" (128.57 mm)H x 2.40" (61.07 mm) D		
Mounting	Four screw holes on removable zinc-plated steel base (designed for 2.75" snap track)		
Electrical Connection	Screw type terminal strip		
Pressure Fittings	3/16" OD barbed brass pressure fitting for 1/4" push-on tubing		
Zero and Span Adjustments	Accessible on top of case		
Weight (approximate)	10 ounces		
Pressure Media			
Typically air or similar non-conducting gases			
Electrical Data—Voltage			
Circuit	3-wire (Com, Exc, Out)		

Excitation	9 - 30 Vdc
Output ⁴	0 - 5 Vdc ⁵
Bi-directional output at zero pressure	2.5 Vdc ⁶
Output impedance	100Ω
Electrical Data—Current	
Circuit	2-wire
Output ⁷	4 - 20 mA ⁸
Bi-directional output at zero pressure	12 mA ⁹
Minimum supply voltage (Vdc)	9+0.02 x (resistance of receiver plus line)
Maximum supply voltage (Vdc)	30+0.004 x (resistance of receiver plus line)

¹ RSS of non-linearity, hysteresis and non-repeatability.

² Units calibrated at nominal 70 °F. Maximum thermal error computed from this datum.

³ Operating temperature limits of the electronics only. Pressure media temperatures may be considerably higher.

⁴ Calibrated into a 50KΩ load, operable into a 5KΩ load or greater.

⁵ Zero output factory set to within ± 50 mV (± 25 mV for optional accuracies).

⁶ Span (full scale) output factory set to within ± 50 mV (± 25 mV for optional accuracies).

⁷ Calibrated at factory with a 24 Vdc loop supply voltage and a 250Ω load.

⁸ Zero output factory set to within ± 0.16 mA (± 0.08 mA for optional accuracies).

⁹ Span (full scale) output factory set to within ± 0.16 mA (± 0.08 mA for optional accuracies).

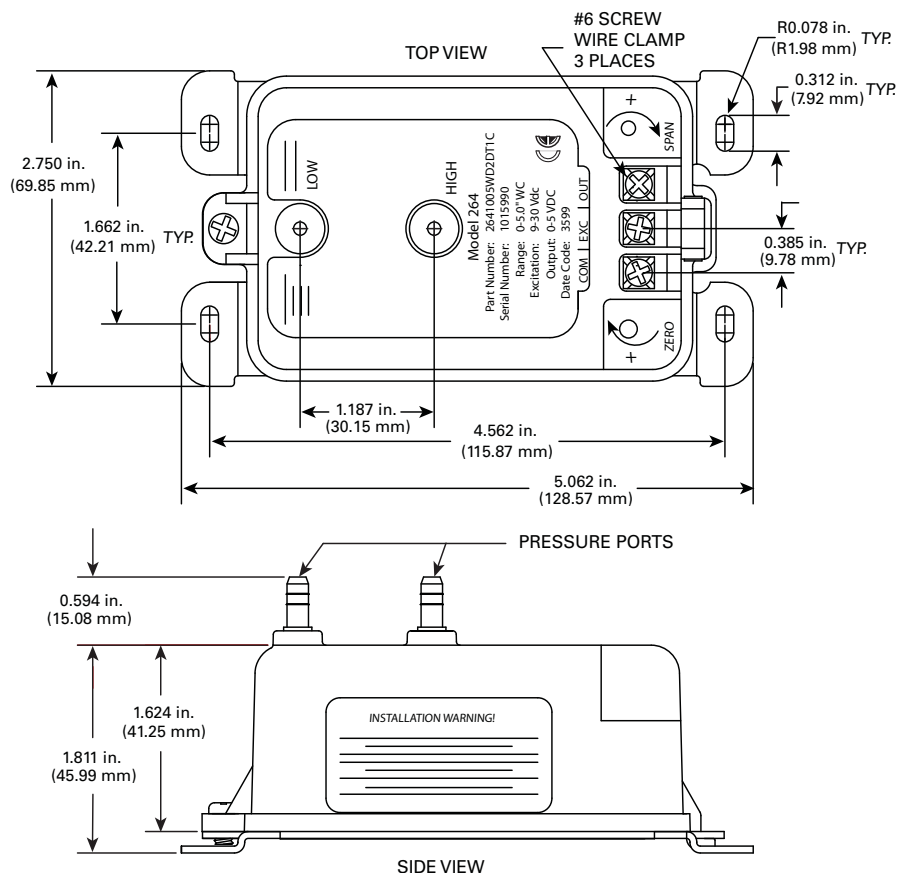

Model 267 Pressure Transducer (0-10 V Output)

Performance Data			
	Standard Accuracy	Mid-Range Accuracy	High Accuracy
Accuracy ¹ RSS (at constant temperature)	± 1.0 % FS	± 0.4 % FS	± 0.25 % FS
Non-linearity (BFSL)	± 0.98 % FS	± 0.38 % FS	± 0.22 % FS
Hysteresis	0.10% FS	± 0.10 % FS	0.10% FS
Non-repeatability	0.05% FS	± 0.05 % FS	0.05% FS
Thermal Effects²			
Compensated Range °F (°C)	40 - 150 (5 - 65)		
Zero/Span Shift % FS/°F (°C)	± 0.033 (± 0.06)		
Maximum Line Pressure	10 psi		
Overpressure	Up to 10 psi (range dependent)		
Warm-up Shift	± 0.1% FS Total		
Position Effect	Range	Zero Offset (% FS/G)	
Unit is factory calibrated at 0g effect in the vertical position	To 0.5" WC	0.60	
	To 1.0" WC	0.50	
Environmental Data			
Temperature			
Operating ³ °F (°C)	0 - +150 (-18 - +65)		
Storage °F (°C)	+65 - +180 (-54 - +82)		
Physical Description			
Case	IP65/NEMA plastic-filled polycarbonate (UL94 V-0 Approved)		
Dimensions	6.20" (158 mm) W x 2.68" (68 mm) H x 3.65" (93 mm) D		
Electrical Connection	Screw type terminal strip		
Electrical Termination	PG-9/PG13.5 Strain relief, 1/2" conduit opening, or 9-pin D-sub connector NOTE: 9-pin D-sub connector is not suitable for NEMA4/IP-65 environments		
Pressure Fittings	3/16" O.D. barbed brass for 1/4" push-on tubing (Standard) Static Pressure Probe (Optional) 1/4" NPTF brass (Optional)		
Weight (approximate)	9 ounces (255 g)		
Display	3-1/2 digit LCD integral display (1.74" (44.1 mm) W x 0.78" (19.8 mm) H)		
Pressure Media			
Typically air or similar non-conducting gases			
Electrical Data—Voltage			
Circuit	3-wire (Exc, Gnd, Sig)		
Excitation/Output (0-5 Vdc output)	9 - 30 Vac / 12 - 40 Vdc		
Excitation/Output (0-10 Vdc output)	11 - 30 Vac / 13 - 40 Vdc		

Bi-directional output at zero pressure	Mid-range of specified output		
Output impedance	100Ω		
Re-ranging	5 position dip switches (inside case)		
Electrical Data—Current			
Circuit	2-wire protected from miswiring		
Output ⁶	4 - 20 mA ⁷		
External Load	0 - 800Ω		
Bi-directional output at zero pressure	12 mA		
Minimum loop supply voltage (Vdc)	9 + 0.02 x (resistance of receiver plus line)		
Maximum supply voltage (Vdc)	30 + 0.004 x (resistance of receiver plus line)		
Re-ranging	4 position dip switches (inside case)		

¹ RSS of non-linearity, hysteresis and non-repeatability.

² Units calibrated at nominal 70 °F. Maximum thermal error computed from this datum.

³ Operating temperature limits of the electronics only. Pressure media temperatures may be considerably higher or lower.

⁴ Calibrated into a 50K Ω load, operable into a 5K Ω load or greater.

⁵ Zero output factory set to within ± 50 mV (± 25 mV for optional accuracies).

Span (full scale) output factory set to within ± 50 mV (± 25 mV for optional accuracies).

⁶ Calibrated at factory with a 24 Vdc loop supply voltage and a 250 Ω load.

⁷ Zero output factory set to within ± 0.16 mA (± 0.08 mA for optional accuracies).

Span (full scale) output factory set to within ± 0.16 mA (± 0.08 mA for optional accuracies).

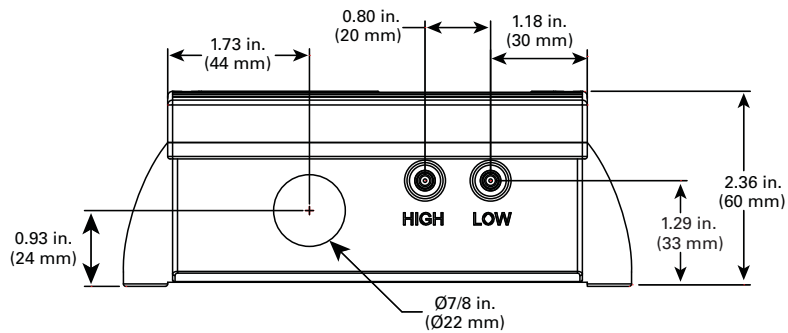
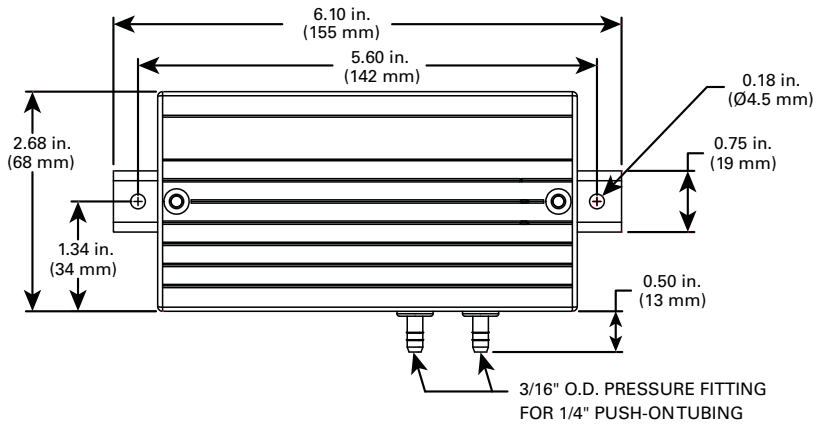

Remote Annunciator

Enclosure	2.75" W x 4.5" H stainless steel wall cover plate
External Supply	15 Vdc, 50 mA maximum
Display Panel	Green and red LED indicators and Acknowledge (ACK) switch
Audible Alarm	0-85 dBA measured 4" from annunciator
Acknowledge Switch	Momentarily turns off audible alarm

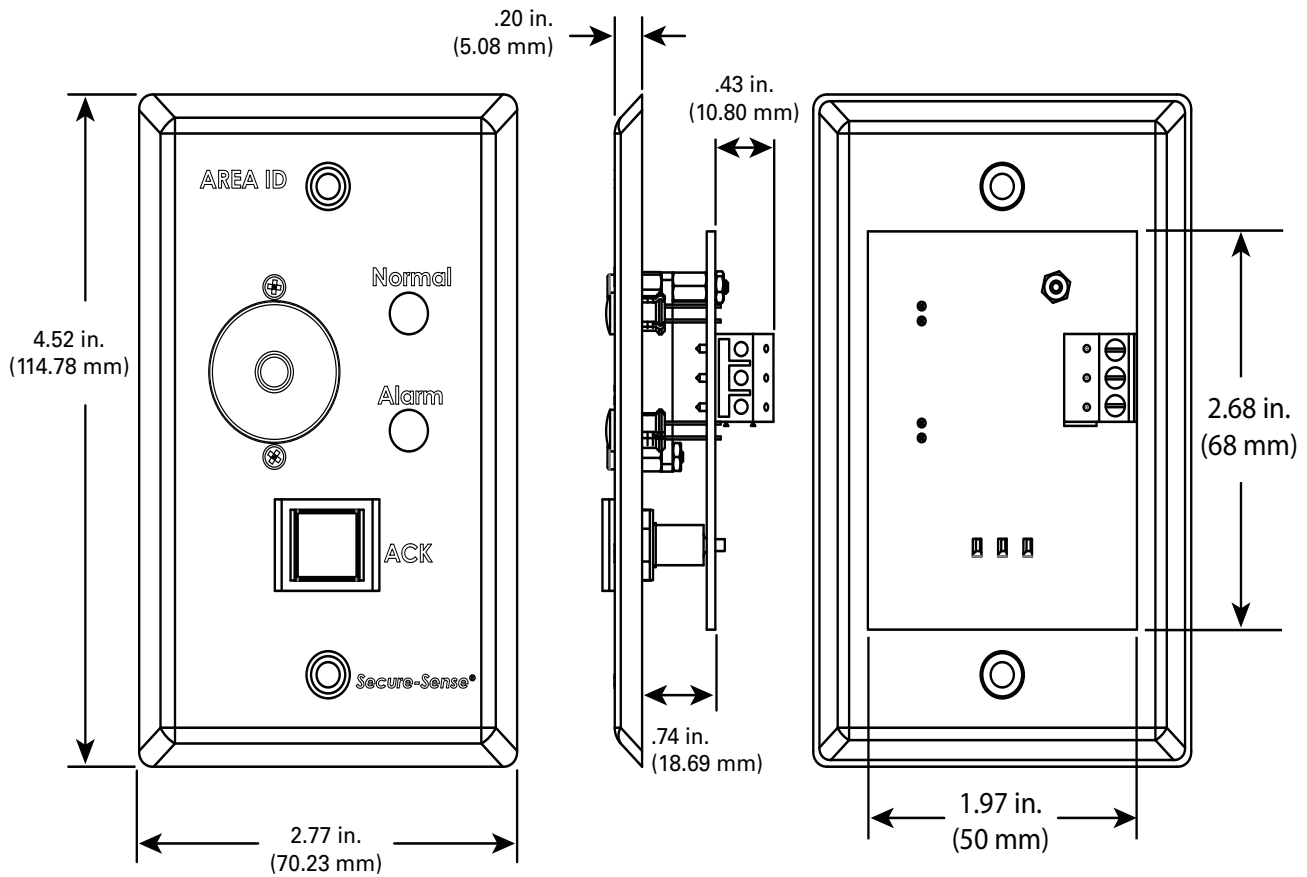

Pressure Pickup Port

Cover	Stainless steel standard wall cover plate
Mounting	Standard single gang electrical box (2 screws included)
Dimensions	2.77" (70.23 mm) W x 4.52" (114.78 mm) H x 1.02" (26.08 mm) D
Pressure Fitting	1/4" flexible push-on tubing (Standard)

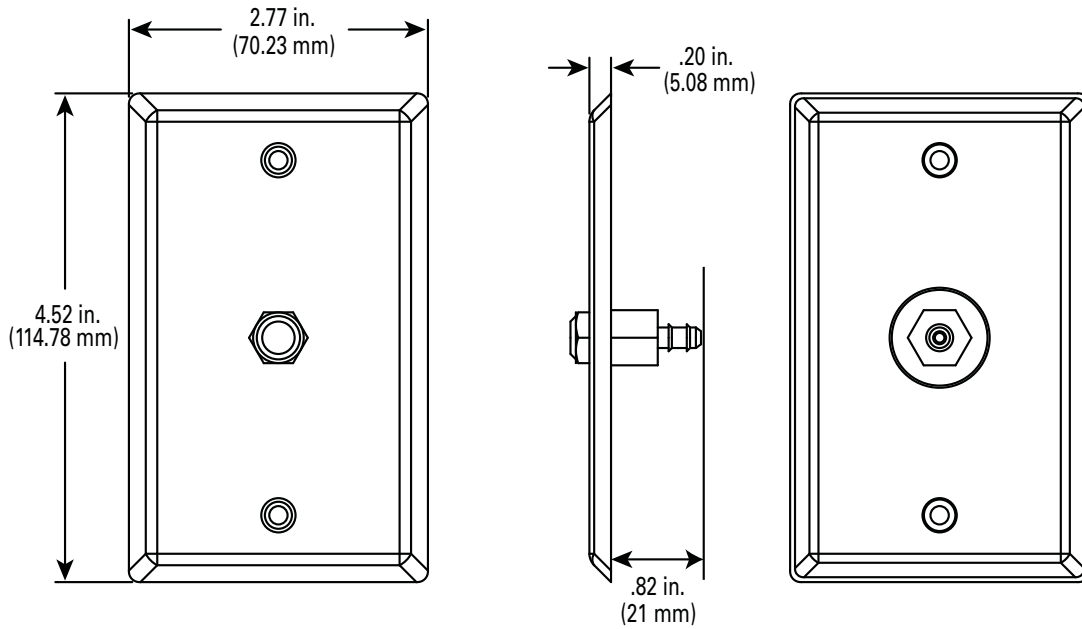

PHOENIX RECOMMENDED CABLES

Cable Type	Plenum Rated	Function	Wire Gauge	Primary Vendor/Part #	Alternate Vendor/Part #	Color Code	Notes
TSP	No	I/O signal wiring	22	Belden 9501		1: Black&Red	Twisted Shielded Pair
2 TSP	No	I/O signal wiring	22	Belden 9502		1: Black&Red 2: Black&White	Two Twisted Pair, Shielded
3C Round	No	Signal	22	Belden 8443		1: Red 2: Black 3: Green	Must be stranded
3C or 4C Round	Yes	Signal	22	Belden 88444	Windy City 004380	1: Red 2: Black 3: Green 4: White (not used as 3C)	Must be stranded
4C Round	No	Signal	22	Belden 8444	Manhattan M13304	1: White 2: Green 3: Black 4: Red	Must be stranded
5C Round	No	Signal	22	Belden 8445	Manhattan M13305	1: White 2: Brown 3: Black 4: Red 5: Green	Must be stranded
8C	No	Signal	22	Belden 9421	Manhattan M13308	1: White 2: Orange 3: Black 4: Red 5: Green 6: Yellow 7: Blue 8: Brown	No substitutes
8C	Yes	Signal	22	Comtran 4956		1: White 2: Orange 3: Black 4: Red 5: Green 6: Yellow 7: Blue 8: Brown	No substitutes
3C MS/TP	No	Shielded	22	Belden 3106A (120 ohm)		1: White with Orange stripe 2: Orange with White stripe 3: Blue with White stripe	Shielded with drain
3C MS/TP	Yes	Shielded	22	Connect-Air W223C-2060YPC		1: Black 2: White 3: Red	Foil shield with drain wire