



# RIW - Scheibenbremsen

## RIW – Disk brakes

Bauart / design ASKU SCHOLTEN

# NO 18931

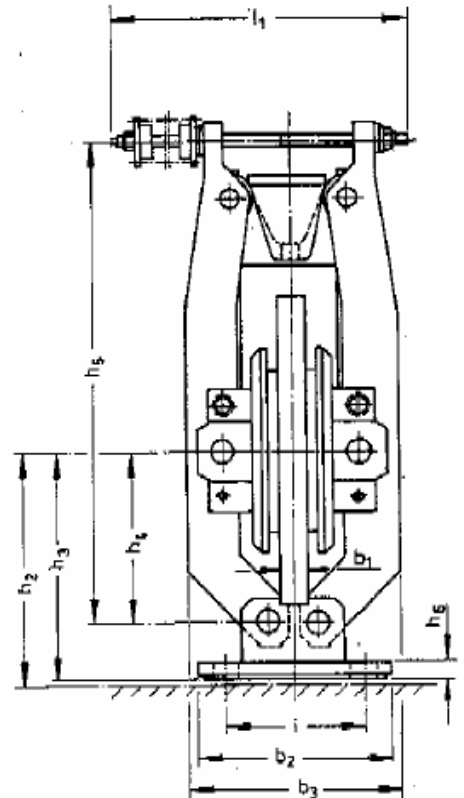
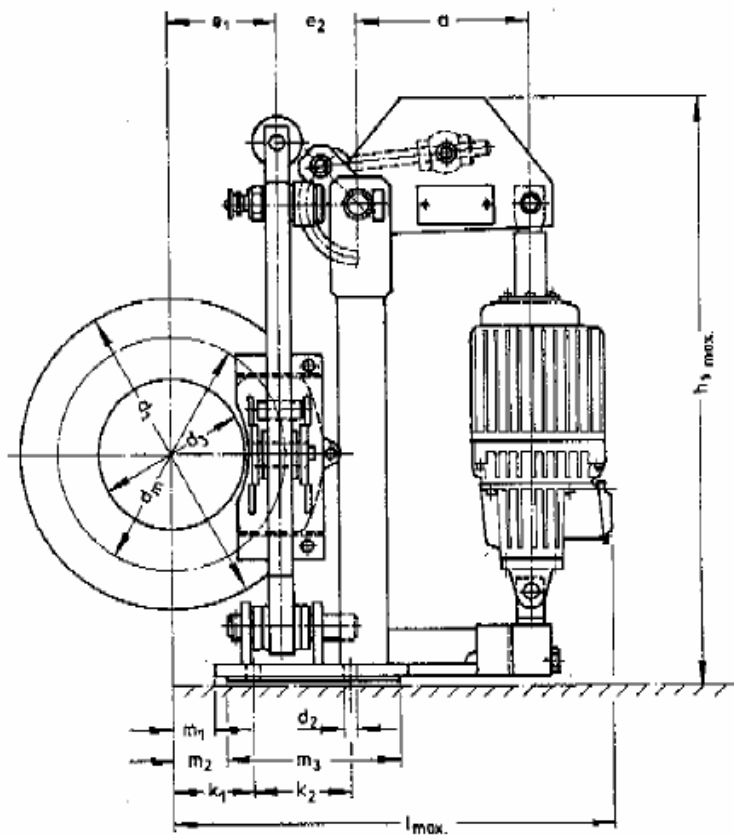

Bezeichnung einer Scheibenbremse  $\varnothing 510$  für Lüftgerät  
Ed 121/12 .....  
RIW – Scheibenbremse 510 – 121/12 NO 18931

Designation of a disk brake  $\varnothing 510$  for brake lifter  
Ed 121/12 .....  
RIW – Disk brake 510 – 121/12 NO 18931

Brems- scheib e brake disk  d <sub>1</sub>	Abmessungen – dimensions ( mm )																				Stück- gewicht unit weight ≈ kg	Lüfter lifter Ed	Kupplg Nabe coupl. hub d <sub>3 max.</sub>	M <sub>B max.</sub> μ=0,4 Nm		
	a	b <sub>1</sub>	b <sub>2</sub>	b <sub>3</sub>	d <sub>2</sub>	d <sub>m</sub>	e <sub>1</sub>	e <sub>2</sub>	h <sub>1</sub>	h <sub>2</sub>	h <sub>3</sub>	h <sub>4</sub>	h <sub>5</sub>	h <sub>6</sub>	i	k <sub>1</sub>	k <sub>2</sub>	l	l <sub>1</sub>	m <sub>1</sub>					m <sub>2</sub>	m <sub>3</sub>
315	180	30	200	220	14	246	110	80	570	230	225	170	480	17	140	70	80	487	375	50	55	180		30/5	145	
400	220	30	240	280	14	316	140	82,5	750	280	270	215	580	17	180	90	100	599	425	70	75	210		50/6	200	
	240																	619						80/12		
																										121/12
																										80/12
510	360	30	290	320	18	396	174	97	940	340	330	265	710	20	220	110	130	781	520	85	90	260		80/12	260	
									987															121/12		
									940															185/16		
640																								121/12	300	
																								185/16		
																								201/12		
	330	30	360	370	27	520	240	90	1155	420	410	325	890	25	270	165	150	837	795	135	140	295		301/12		

Diese Tabelle soll lediglich einen Überblick von einigen ausgeführten Scheibenbremsen geben. Selbstverständlich sind wir in der Lage, für jeden Bedarfsfall, d.h. für jedes Bremsmoment und jede Bremskraft die optimale Lösung zu finden.

RIW – Elastische Kupplung mit Bremscheibe siehe NO 15442.

This table shall give only a view on a few delivered disk brakes.

Selfevident, we are in a position to find an optimal solution for each demand, i.e. each brake moment and each brake force.

RIW – Elastic coupling with brake disk see NO 15442.

# RIW

MASCHINENBAU  
KRANTECHNIK

GM  
BH

47119 Duisburg  
Vincweg 15

Telefon: 0203/8096 - 0  
Telefax: 0203/8096 - 183