

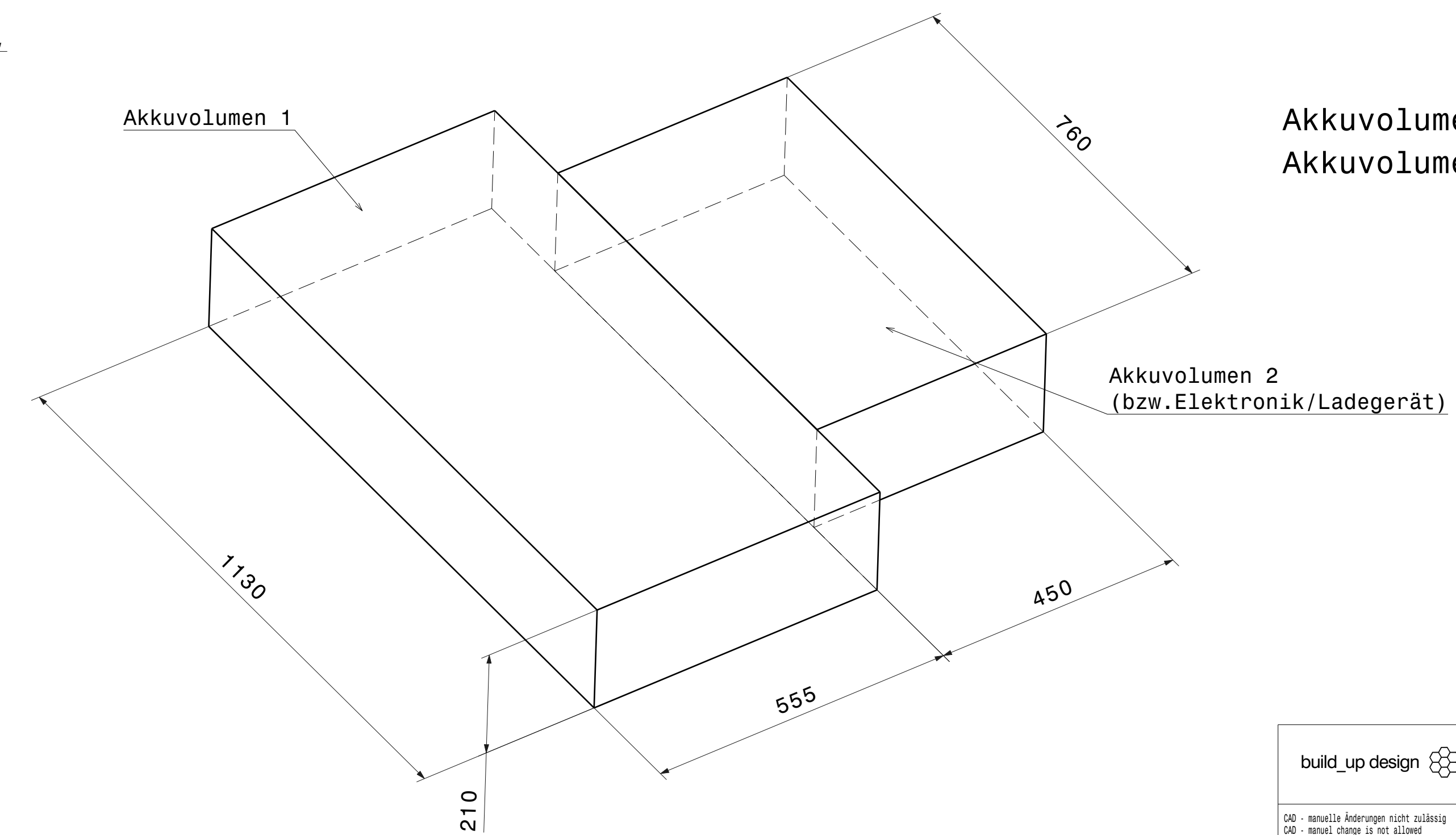

Hotzenblitz mit KREISEL Akku /Antrieb

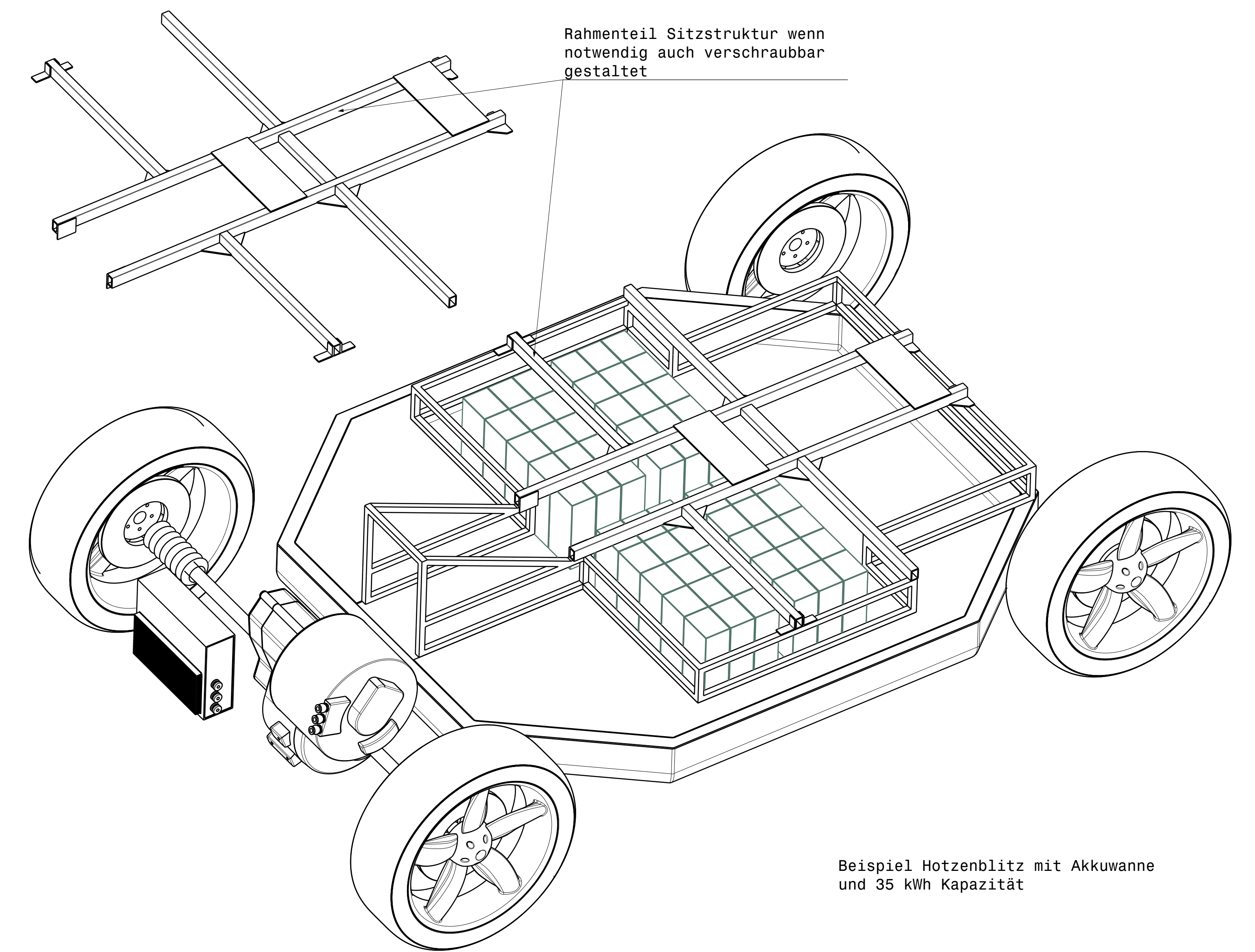
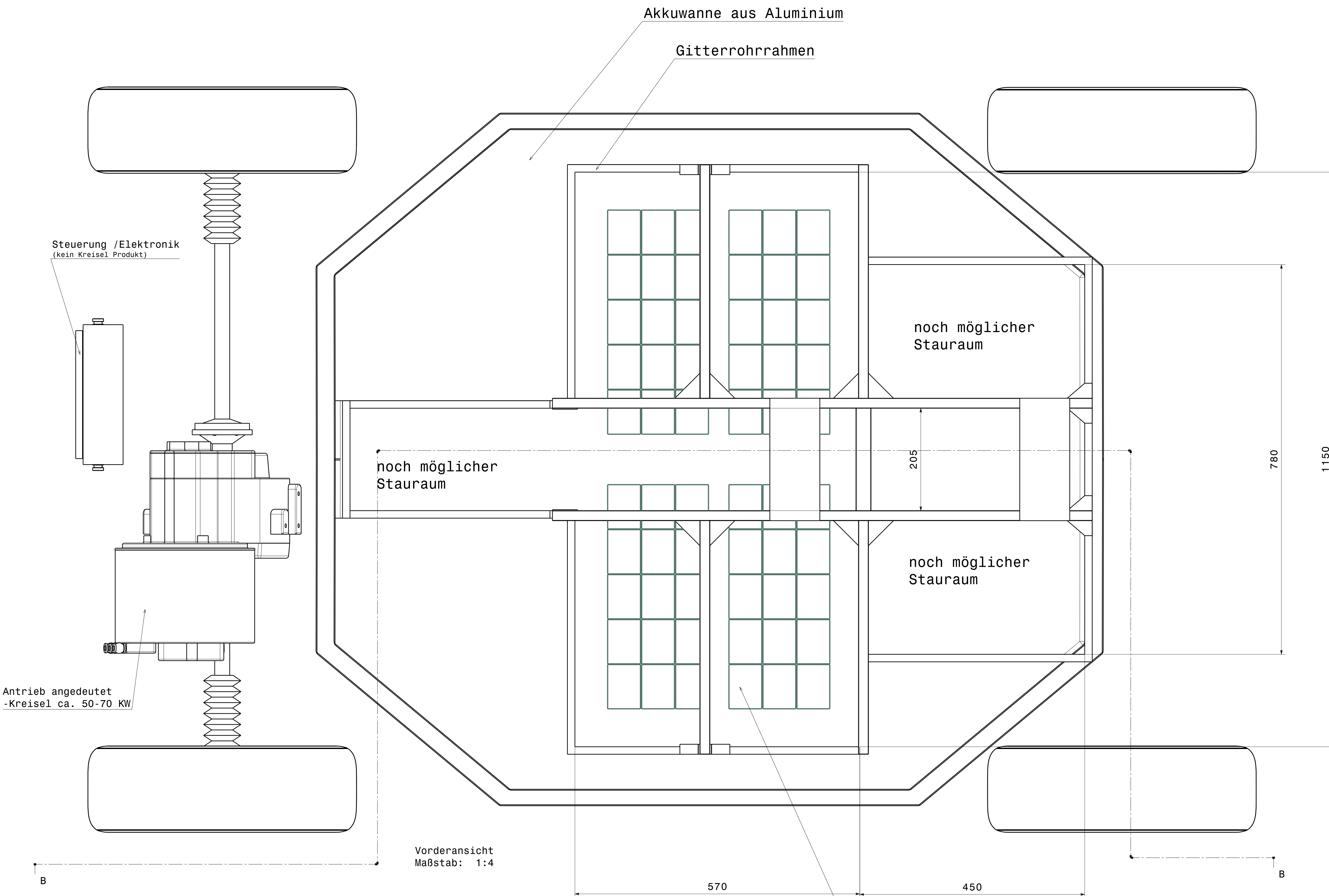
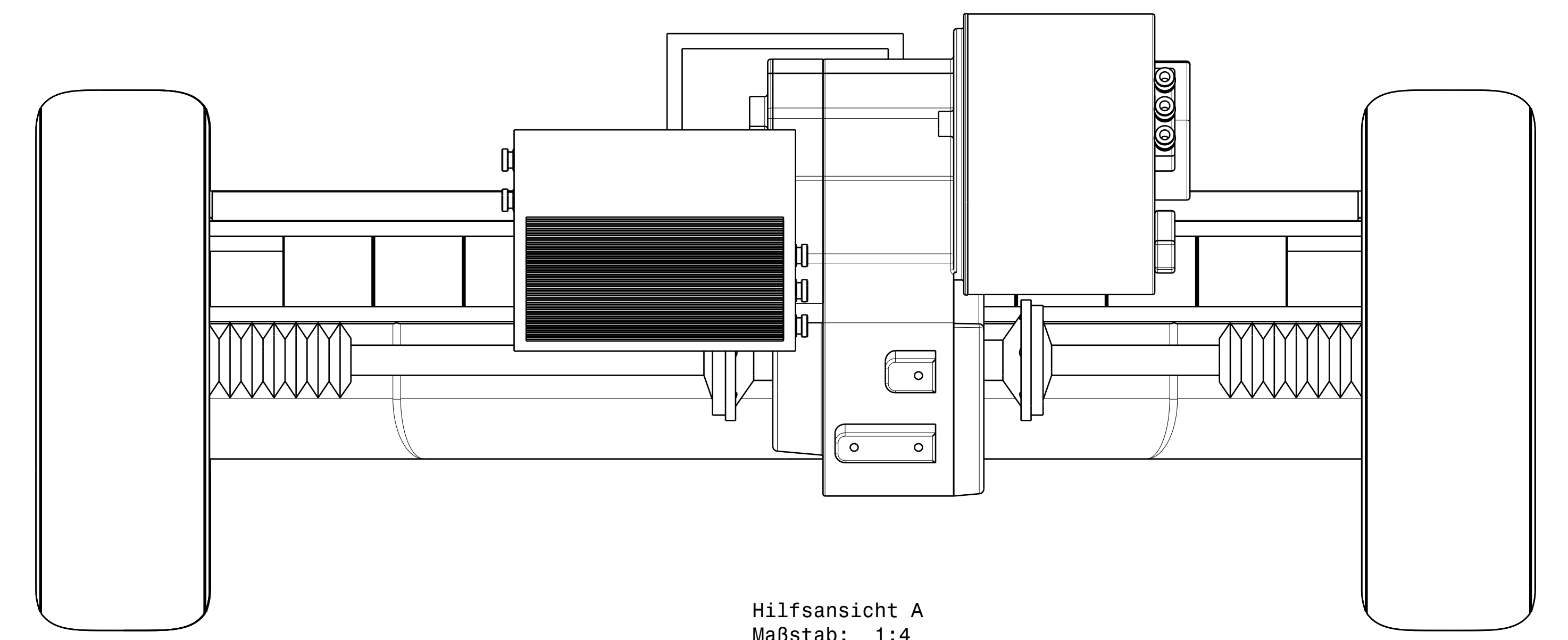
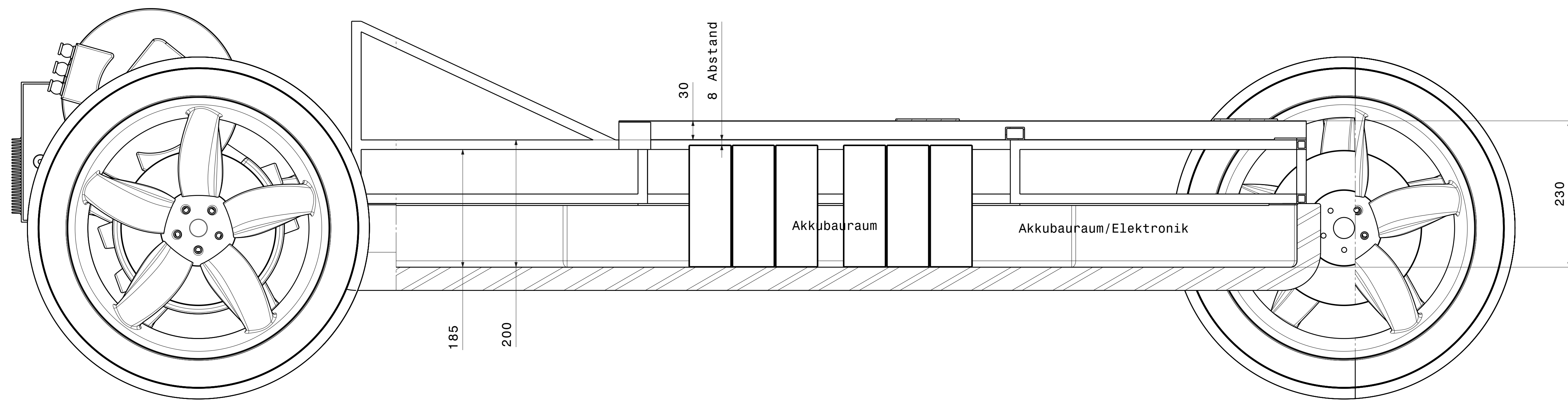

Akkuvolumen 1: ca. 130 Liter
Akkuvolumen 2: ca. 70 Liter

Beispiel Gesamtkaku : 4 x Akkupack

Kapazität: 35 kWh
Spannung: 218 Volt (seriell)
Gewicht: 156 kg

KREISEL 

BLIRND 46P LQ 2,6 kg
3,635 V Nennspannung
585,2 Wh Energiegehalt
161 Ah
1,14 dm³
192,0 x 89,5 x 66,7 mm (LxBxH)

KREISEL 

Akkupack:
15 Akkus BLIRND 46P LQ
54,5 Volt
8,8 kWh
39Kg

build_up design 	Allegemeinbereich generell, tolerance ISO 2768-mk	Maßstab 1:1	Lagerplatz Stoffe, Lacke Herstellf., Maßstabmaterial	Dokument ZB-Z
00 - werka 01 - werka 02 - werka 03 - werka 04 - werka 05 - werka 06 - werka 07 - werka 08 - werka 09 - werka 10 - werka 11 - werka 12 - werka 13 - werka 14 - werka 15 - werka 16 - werka 17 - werka 18 - werka 19 - werka 20 - werka 21 - werka 22 - werka 23 - werka 24 - werka 25 - werka 26 - werka 27 - werka 28 - werka 29 - werka 30 - werka 31 - werka 32 - werka 33 - werka 34 - werka 35 - werka 36 - werka 37 - werka 38 - werka 39 - werka 40 - werka 41 - werka 42 - werka 43 - werka 44 - werka 45 - werka 46 - werka 47 - werka 48 - werka 49 - werka 50 - werka 51 - werka 52 - werka 53 - werka 54 - werka 55 - werka 56 - werka 57 - werka 58 - werka 59 - werka 60 - werka 61 - werka 62 - werka 63 - werka 64 - werka 65 - werka 66 - werka 67 - werka 68 - werka 69 - werka 70 - werka 71 - werka 72 - werka 73 - werka 74 - werka 75 - werka 76 - werka 77 - werka 78 - werka 79 - werka 80 - werka 81 - werka 82 - werka 83 - werka 84 - werka 85 - werka 86 - werka 87 - werka 88 - werka 89 - werka 90 - werka 91 - werka 92 - werka 93 - werka 94 - werka 95 - werka 96 - werka 97 - werka 98 - werka 99 - werka	Projekt Hotzenblitz neuer Antrieb und Akku	AD		