

HYUNDAI

PETROL INVERTER GENERATOR

Models HY1000Si - HY2000Si

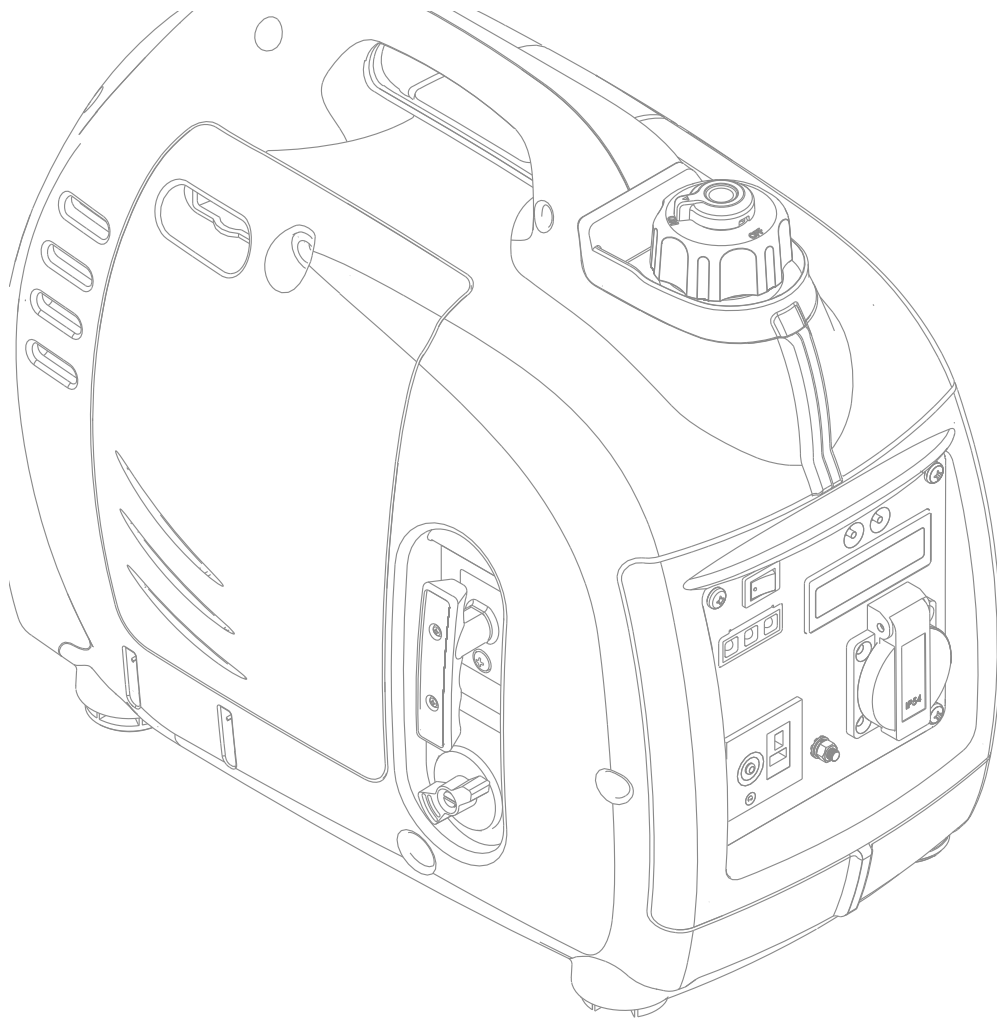

User Guide

Licensed by Hyundai Corporation, Korea

CONTENTS

1.0	Safety Information	03
2.0	Safety Label Location	04
3.0	Component Identification	05
1	Control Panel	06
2	ECON Switch	06
3	Hour Meter	07
4.0	Pre-operation Checks	08
1	Oil Level Check	09
2	Fuel Level Check	10
3	Air Filter Check	10
5.0	Starting the Engine	11
6.0	Generator Use	13
1	DC Applications	14
2	AC Applications	16
3	Output & Overload Indicator	16
4	Oil Alert System	17
7.0	Stopping the Engine	18
8.0	Maintenance	19
1	Oil Change	19
2	Air Cleaner Service	20
3	Spark Plug Service	22
4	Spark Arrester Maintenance	23
9.0	Transporting/Storage	25
10.0	Troubleshooting	27
11.0	Technical Specifications	28 - 29
12.0	Wiring Diagrams	30
13.0	Appendix	31
1	EC DEclarations of Conformity	31
2	Environmental Corrections	32
3	Noise & Access	33
14.0	Consumer Information	33

1.0 Safety Information.

To protect yourself and your property, please carefully read the following instructions.

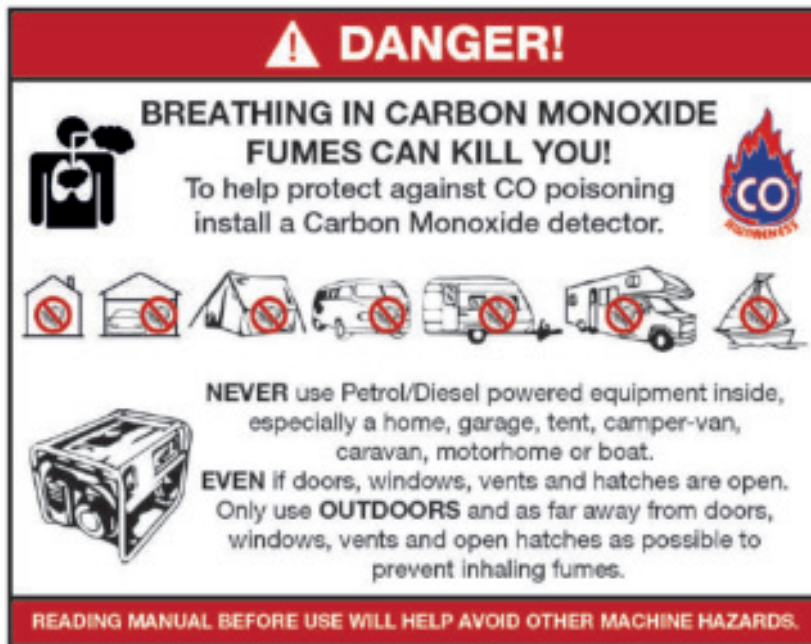

WARNING

- Read and understand the user manual before using the generator.
- DO NOT use in an enclosed area or a moving vehicle. The engine exhaust gas contains poisonous carbon monoxide. Use the generator in a well ventilated area.
- DO NOT touch the hot exhaust. When the generator is running, or before cooling.
- Petrol is explosive and flammable. When refuelling, the generator needs to be stopped, and fuel kept away from all ignition sources i.e. heaters, lamps, sparks from grinding or welding.
- DO NOT connect to the building's electrical system or another generator, in order to avoid electric shocks and fires.
- The generator must be kept one metre away from all other equipment and flammable materials.
- Place the generator on a the level surface, in order to avoid overturning or spilling fuel.
- Children and pets should be kept away from the generator at all times especially when in operation.
- DO NOT operate with wet hand/s.
- DO NOT let the generator to come into contact with rain, moisture or snow.
- All major repair work should be carried out by a professionally trained person.
- DO NOT use the generator for underground work.
- DO NOT use the generator in potentially explosive atmospheres.
- Always use personal protective equipment when you operate or maintain the generator, e.g. gloves, mask, earplugs.

2.0 Safety Label Locations.

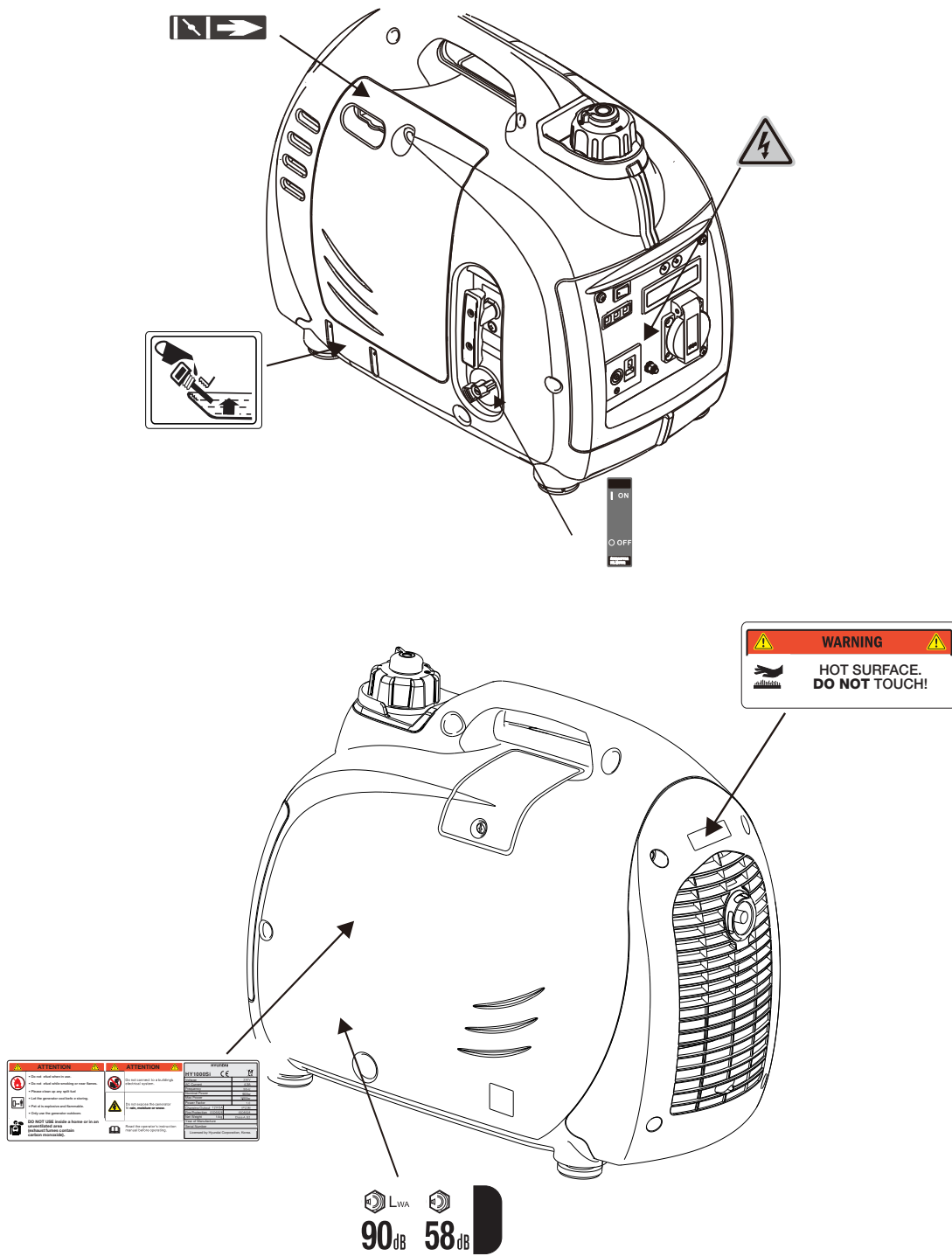

3.0 Component Locations.

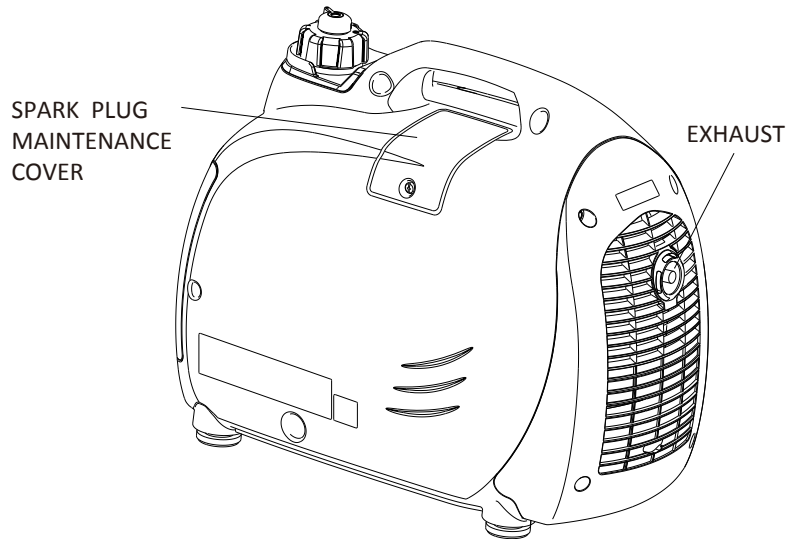
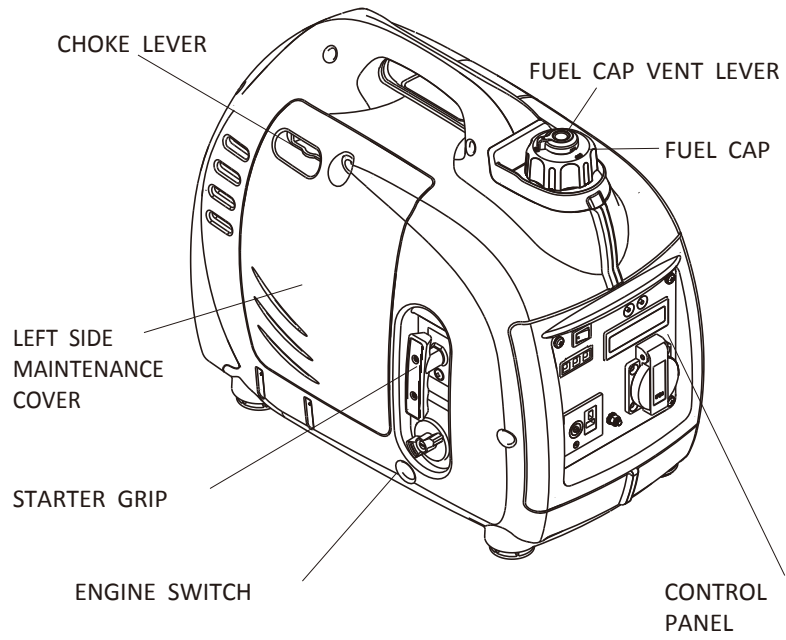

3.1 Control Panel.

- 1 ECON Switch
- 2 Oil Alert Indicator Light RED
- 3 Overload Indicator Light RED
- 4 Output Indicator Light GREEN
- 5 DC Circuit Fuse
- 6 DC Output Socket
- 7 Ground/Earth Terminal
- 8 AC Output Socket
- 9 Hour Meter

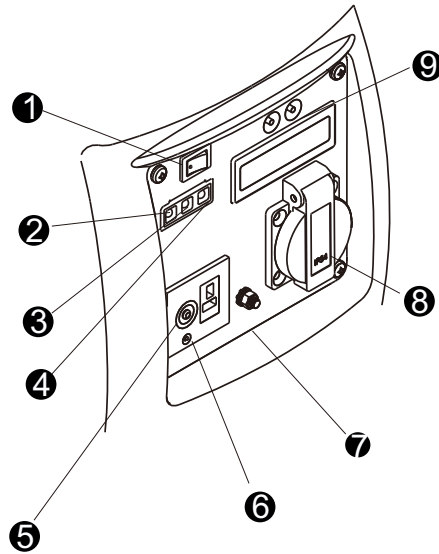

3.2 ECON Switch (Economy Control Switch)

"ON" (🐢)

When the economy control switch is turned to "ON" (🐢) the engine keeps running at idle state automatically when the electrical appliance is disconnected, and will return to the proper speed when the electrical load requires it.

The "ON" (🐢) function is recommended to minimise fuel consumption, reduce noise and prolong engine life.

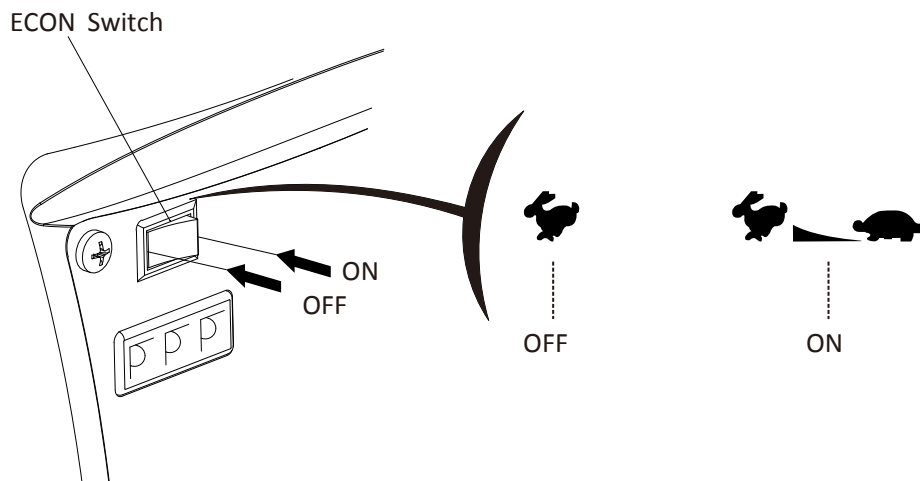

NOTE

When a high load electrical appliance is connected and in order to reduce voltage change, turn the economy control switch to the "OFF" (🔌) position. This will allow the engine speed to increase before the load is applied

In DC operation, turn the economy control switch to the "OFF" (🔌) position.

Connect both AC load and DC load, turn the economy control switch to the "OFF" (🔌) position.

When the economy control switch turns to the "OFF" (🔌) the engine runs at high speed.

3.3 Hour Meter

When the generator goes into overload protection mode, the overload indicator light (RED) will come on, by pressing the "RESET" button the output of the generator can be recovered. It will be unnecessary to restart engine.

Press and hold the "RESET" button for one second, until the overload indicator light (RED) goes off, and the output indicator light (GREEN) comes on.

Under non-overload condition the "RESET" button does not have any function.

When the "DISP" button is pressed the backlight will come on. Successive presses of the "DISP" button will display in turn at each press the Voltage - Frequency - Engine Speed & Cumulative Run Time.

NOTE

If the "DISP" button is not pressed for more than 10 seconds the backlight will turn off.

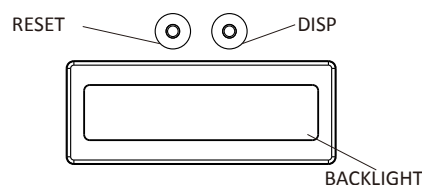

NOTE

When in protection condition, the output indicator light (GREEN) is off and the overload indicator light (RED) is on.

When the generator is started the "RESET" function is available to recover from an overload condition five times, after which time you will have to restart the engine.

4.0 Pre-Operation Checks.

4.1 Oil Level Check.



Make sure that the generator has been stopped and is on a level surface.

Remove the oil filler cap, and clean it with a clean cloth, reinsert the oil filler cap (do not screw it in) remove and check the oil level on the dipstick.

If the level is low, fill to the upper limit of the oil filler neck with the recommended oil.

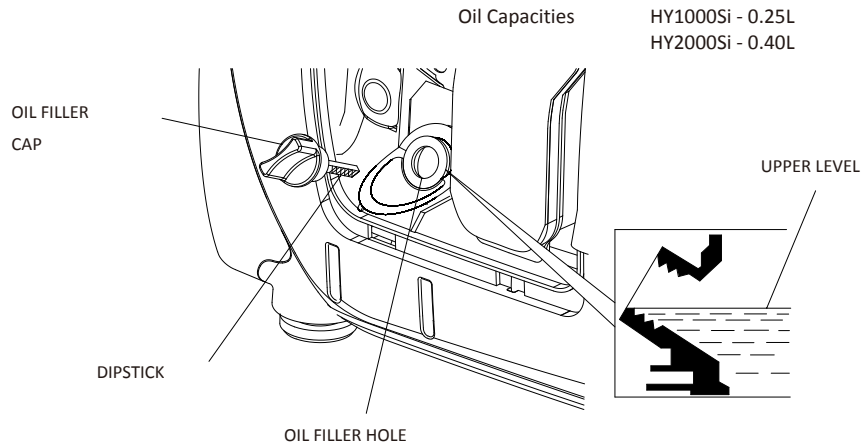

NOTE

DO NOT use non-detergent or 2 stroke oil this could shorten the engines working life.

DO NOT mix different types of engine oil in this engine.

Use a 4 stroke engine oil, certified to meet or exceed API standards: SG, SF or SAE rating.

Make sure that you carefully use and store the engine oil. Avoid getting dirt or dust into the engine oil.

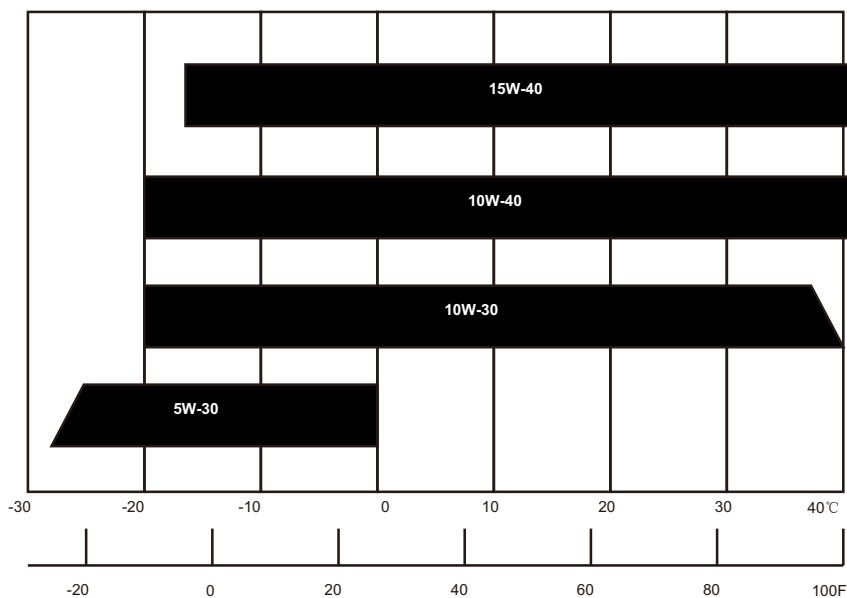

NOTE

If the engine oil falls below the safety margin the low oil alert system will automatically shut off the engine. The oil alert indicator light (RED) will come on. To avoid this inconvenience it is advisable to check the oil regularly

4.2 Fuel Level Check.

Unleaded petrol is the recommended fuel.

Never use stale or contaminated petrol or an oil/petrol mixture.

Avoid getting dirt or water into the fuel tank.

Do not use a mixture petrol containing ethanol or methanol. This will seriously damage the engine.

FUEL CAP

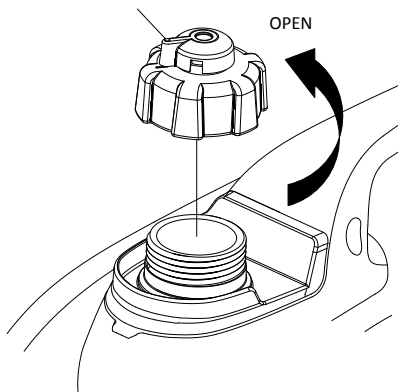

UPPER LIMIT MARK

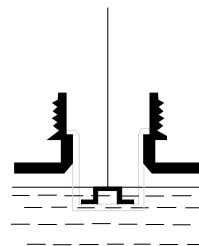

Fuel capacities: HY1000Si - 2.2L, HY2000Si 3.8L



Petrol is extremely explosive and flammable.

DO NOT smoke or allow naked flames or sources of ignition in or around the fuelling area or in fuel storage areas.

DO NOT overfill the fuel tank (DO NOT fuel above the RED upper limit mark). After refuelling make sure that the fuel cap is closed and secure properly.

Avoid spilling fuel by using correct refuelling methods. ALWAYS clean up spilt fuel immediately after it occurs.

Avoid breathing in petrol vapours and direct contact with the skin.

KEEP all fuels and oils away from and out of reach from children.

4.3 Air Filter Check.

Check the air cleaner element to make sure that it is clean and in good condition.

- a) Undo and remove the maintenance cover screws, and remove the cover.
- b) Press the latch tab on the top of the air cleaner.
- c) Remove the air cleaner cover.
- d) Check the element, clean and replace as necessary.

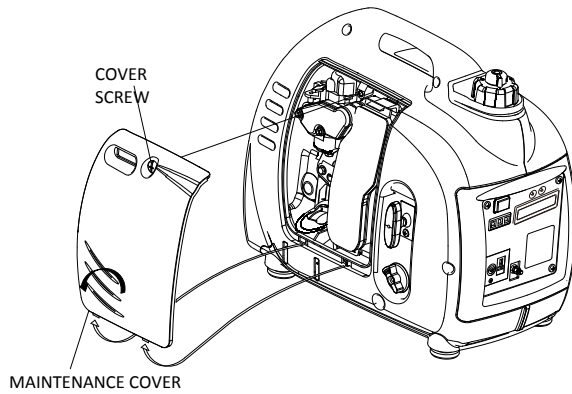

HY1000Si

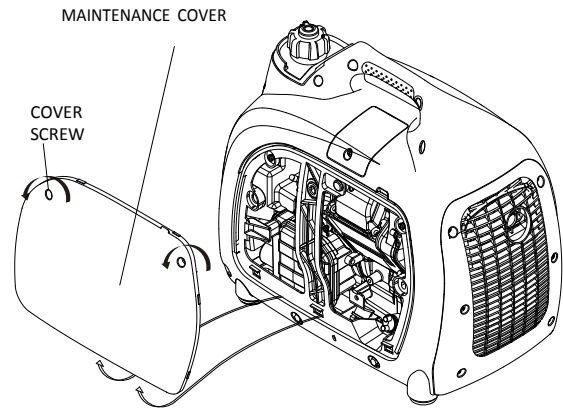

HY2000Si

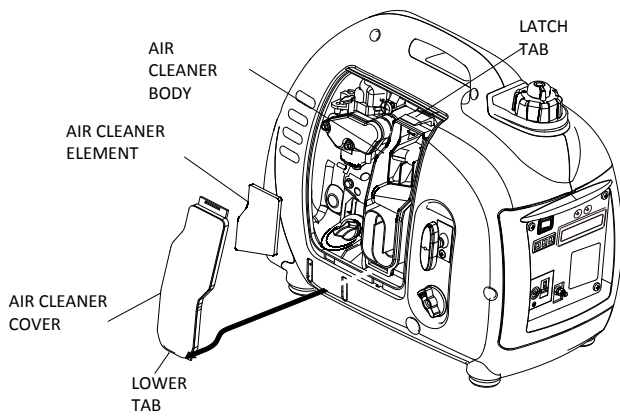

HY1000Si

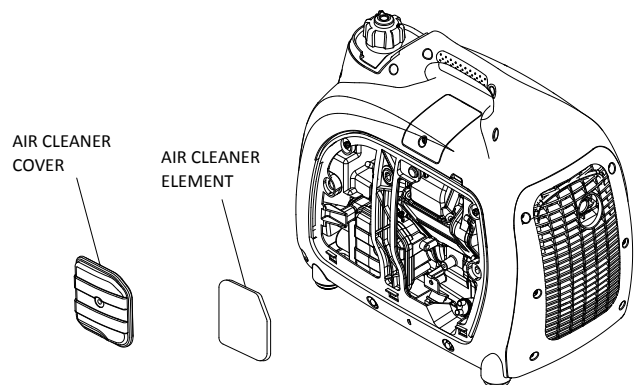

HY2000Si

5.0 Starting the Engine.

NOTE

Before starting the engine ALWAYS disconnect the load from the AC Socket.

When fuelling for the first time, or refuelling after long time storage, the engine switch should be turned on wait for 20 seconds. You will then need to pull the recoil starter 10 to 20 times to draw fuel into the carburettor.

5.1 Turn the fuel cap vent to the "ON" position. When transporting the generator, turn the fuel cap vent lever to the "OFF" position.

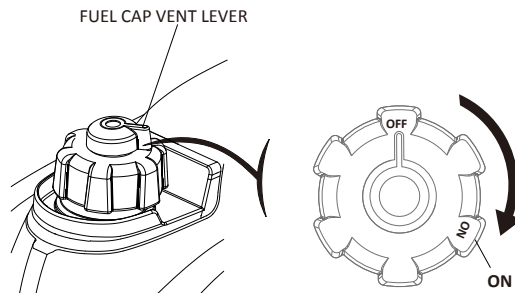

5.2 Turn the engine switch to the "ON" position.

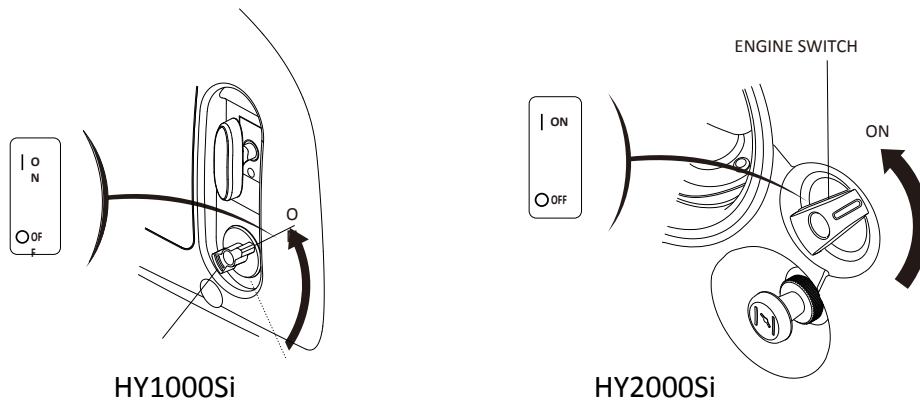

5.3 HY1000Si - Move the choke lever to the "START" position. HY2000Si - Pull the choke knob fully out.

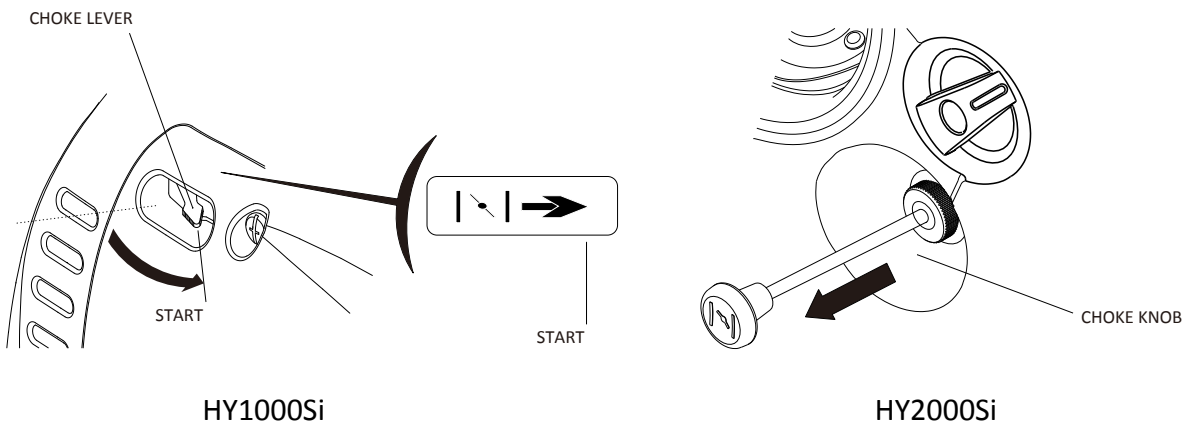

NOTE

DO NOT move the choke lever (HY1000Si) to the "START" position when the engine is hot or ambient temperature is high.

DO NOT pull the choke knob (HY2000Si) to the fully out position when the engine is hot or ambient temperature is high.

5.4 Pull the starter grip lightly until you feel resistance, then pull quickly toward the arrow as shown below.

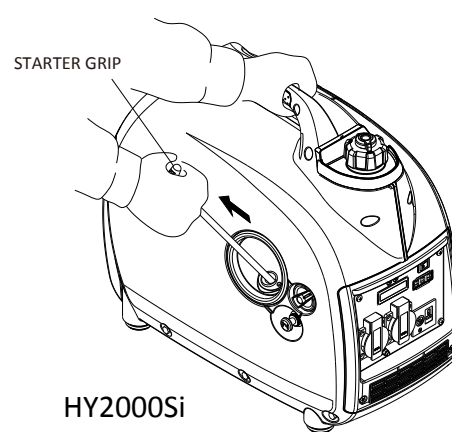
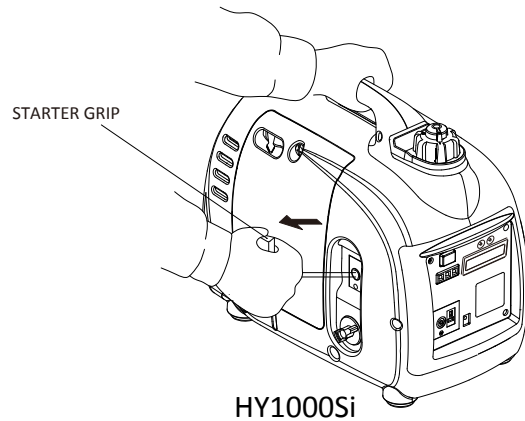

NOTE

Return the starter grip slowly by hand. DO NOT let the starter grip spring back.

5.5 After starting and warming up the engine, turn the choke lever (HY1000Si) to the "RUN" position.

After starting and warming up the engine, push the choke knob (HY2000Si) to the normal position.

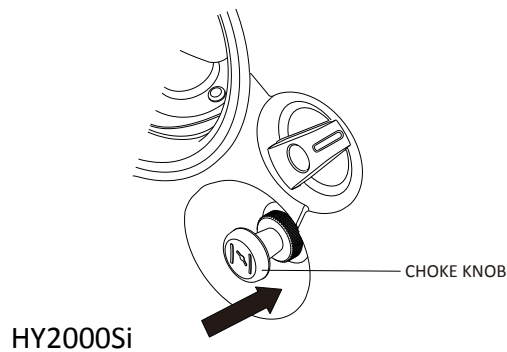
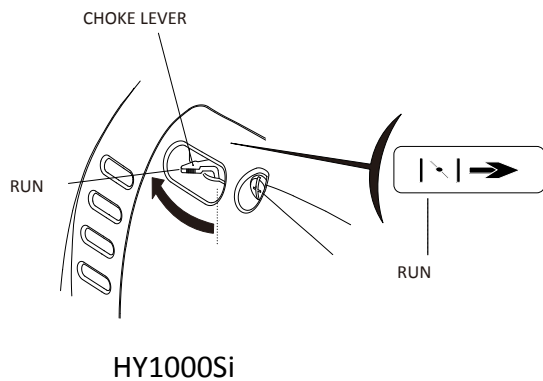

NOTE

If the generator stops and cannot be restarted check the oil level first.

Carburettor Modification for High Altitude Operation.

At high altitude, the standard carburetor air-fuel mixture will be too rich. Performance will decrease, and fuel consumption will increase. A very rich mixture will also foul the spark plug and cause difficult starting. If the generator operates at high altitude, change the main-nozzle or adjust the idling screw of carburetor.

If the generator always operates at altitude above 1,000 meters, contact your dealer to modify the carburetor.

Generator output power should be modified according to the altitude and ambient temperature. The correction factor refers to 13-2.

⚠ WARNING

If the carburetor has been modified for high altitude operation, the air-fuel mixture will be too lean for low altitude use. Operation at low altitude may cause the engine to overheat and result in serious engine damage. The carburetor needs to be returned to its original specification.

6.0 Generator Use.

⚠ WARNING

Make sure to ground/earth the generator when the connected appliance is grounded/earthed. DO NOT connect to the buildings electrical system. Back feeding it is both illegal and highly dangerous.

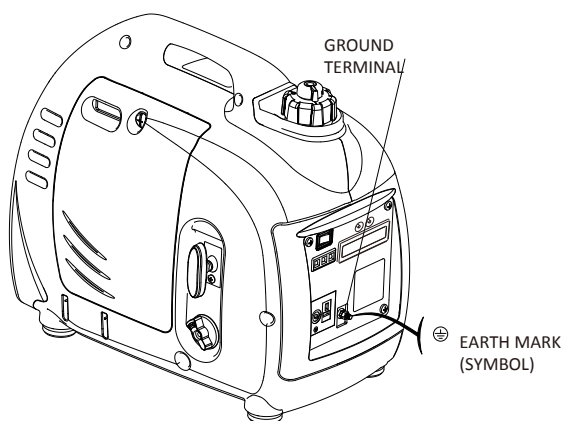

HY1000Si

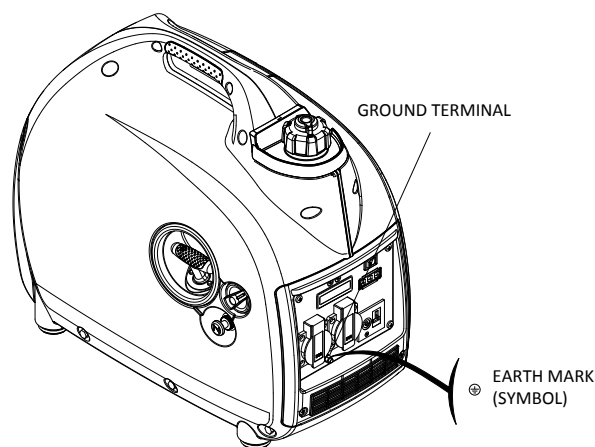

HY2000Si

WARNING

For continuous operation, do not exceed the rated output power of the generator.

DO NOT make parallel connection with mains electrical installations or other generators.

DO NOT connect an extension to the exhaust pipe.

When an extension cable is required, make sure that you use a tough rubber sheathed flexible cable (according to IEC245 or equivalent standards). The length of the extension cable:

60m for cable of 1.5 mm

100m for cable of 2.5 mm

Keep away from other electric cables or wires.

NOTE

The AC socket outlet can be used while the DC power is in use. If using both at same time, be sure not to exceed the total power for AC and DC. (**HY1000Si** AC - 0.9kVA, DC - 5A) (**HY2000Si** AC - 1.6kVA, DC - 5A).

Most motor appliances require upto 3 times more than their rated wattage when starting.

6.1 DC Application.

The DC receptacle, 15-30V under no-load condition, may be used for charging a 12V battery only.

NOTE

In DC operation, turn the ECON Switch to the "OFF" position (🔌)

6.1.1 Connect the DC receptacle to the battery terminals with the charging cable.

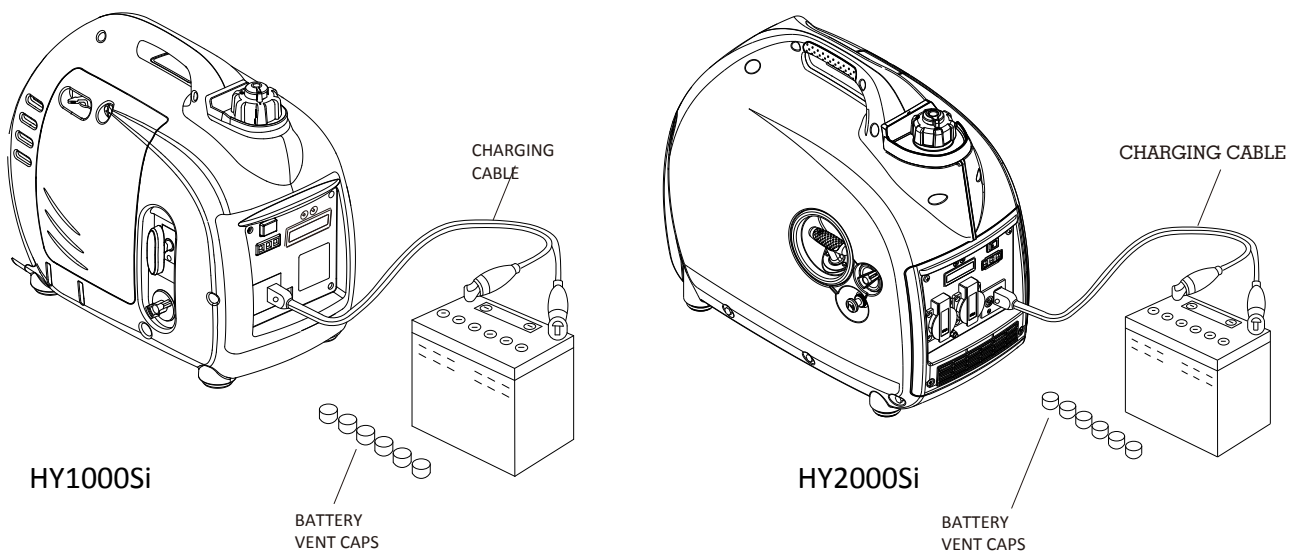

⚠ WARNING

To avoid producing the sparks at the terminals of battery, connect the charging cables firstly to the battery terminals, and then to the generator. When disconnecting the cables do so first at the generator.

Before connecting the charging cables to a battery that is installed in a vehicle, the grounded/chassis cable of the battery should be disconnected first. This sequence will prevent sparks or a short-circuit, if the cable accidentally contacts the vehicle's frame or body.

NOTE

Do not start the car's engine when the generator is still connected to the battery, otherwise the generator will be damaged.

Connect the positive battery terminal to the positive charging cable. Do not reverse the charging cable, otherwise generator or battery will be damaged seriously.

⚠ WARNING

When charging the battery releases highly explosive oxygen/hydrogen gases. Keep the battery away from sparks/fire and other sources of ignition. Always charge the battery in a well ventilated area.

Battery electrolyte contains sulphuric acid which will cause severe burns if it comes into contact with the skin and eyes. Therefore it is necessary to wear the protective clothing and mask.

If battery electrolyte gets into eyes or onto skin, flush thoroughly with warm water for 15 minutes at least, and call a doctor immediately.

If you accidentally swallow any battery electrolyte, call for medical/first aid assistance immediately. If no medical/first aid assistance is available call or get someone else to dial 999.

Keep batteries and electrolyte OUT OF REACH OF CHILDREN.

NOTE

The DC receptacle can be used while the AC power is in use.

When DC circuit overload will trip the DC circuit protector, remove load firstly, and then reset the protector after a few minutes.

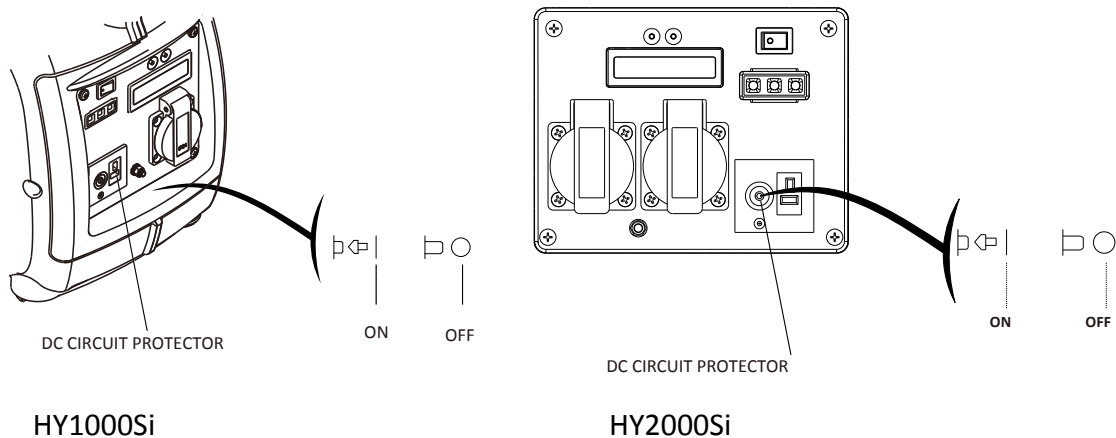

6.2 AC Applications.

6.2.1 Start engine and make sure the output indicator light (GREEN) is on.

6.2.2 Confirm all electrical appliances are switched off, then connect the appliance plugs to the generator AC socket.

NOTE

To obtain the best working and longest working life of the generator, you should make sure that you run the generator for 20 hours at 50% rated load.

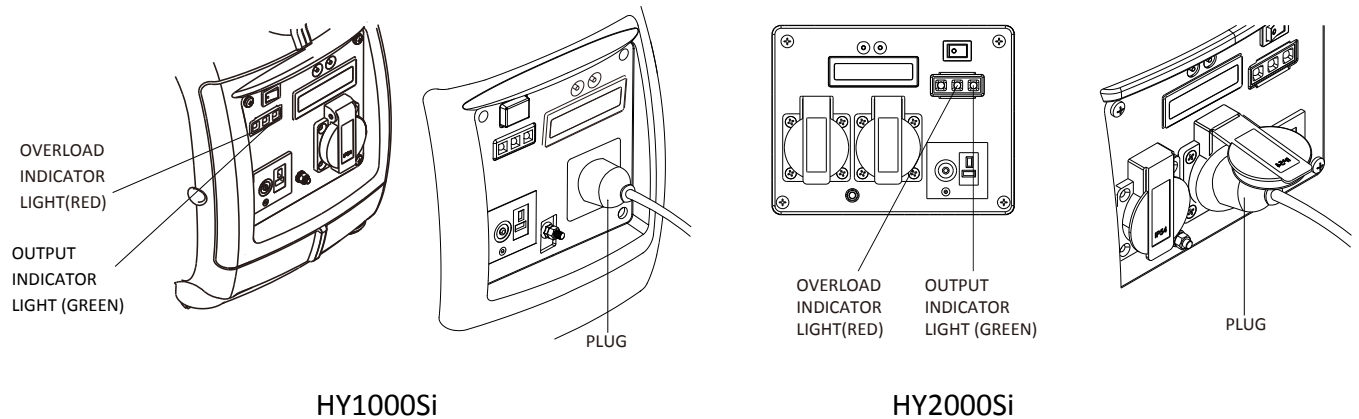

NOTE

Confirm all electrical appliances are in good working condition before connecting them to the generator. If an electrical appliance becomes abnormal, sluggish, or stops suddenly, shut off the generator engine immediately, and disconnect the appliance.

6.3 Output and Overload Indicator

In normal operating conditions, the output indicator light (GREEN) will remain on.

If the generator is overloaded (**HY1000Si** - over 1000w, **HY2000Si** - 2000w), or the connected appliance is short-circuited, the output indicator light (GREEN) will go out, and overload indicator light (RED) will come on. The 230v output will be cut and the engine will remain running.

If the overload indicator light (RED) is on, disconnect the electrical appliances first, then press and hold the reset button for 1 second. If the overload indicator light (RED) is off and the output indicator light (GREEN) is on, reconnect the electrical appliances. Otherwise stop the engine and check the generator.

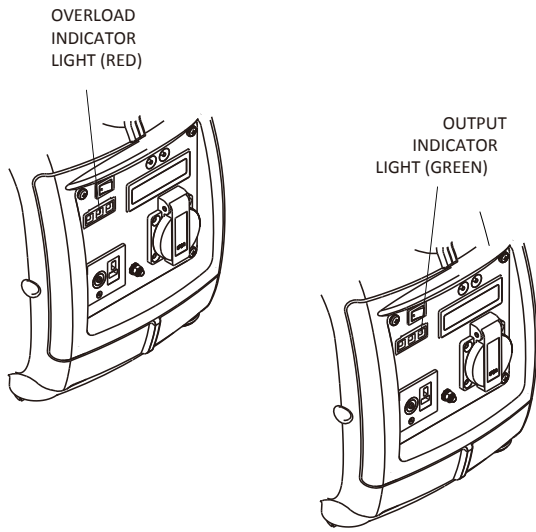

HY1000Si

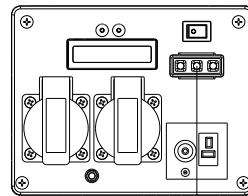

OVERLOAD INDICATOR LIGHT (RED)

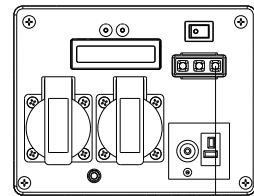

OUTPUT INDICATOR LIGHT (GREEN)

HY2000Si

NOTE

When you start the engine, it is normal for both the overload indicator light (RED) and output indicator light (GREEN) to be ON simultaneously. The overload indicator light will go OFF after 5 seconds, otherwise contact your dealer.

6.4 Oil Alert System.

The oil alert system is designed to prevent engine damage caused by an insufficient amount of oil in the crankcase. Before the oil level in the crankcase falls below a safe limit, the oil alert system will automatically shut down the engine (the engine switch remains in the "ON" position). If the oil alert system shuts down the engine, the oil alert indicator light (red) will be on. Check the engine oil level.

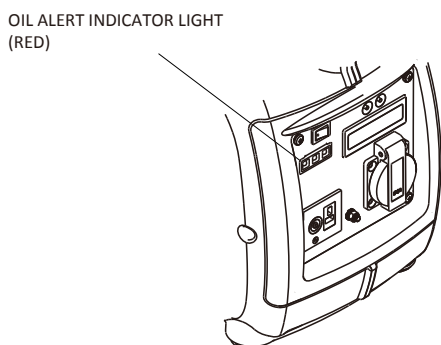

HY1000Si

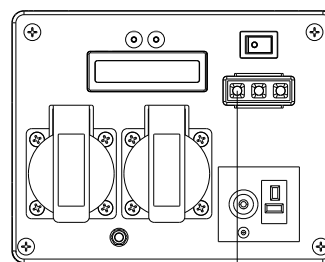

OIL ALERT INDICATOR LIGHT (RED)

HY2000Si

7.0 Stopping the Engine.

To stop the engine in an emergency, turn the engine switch to the “OFF” position.

7.1 Switch off the connected electrical appliances and remove their plugs from the AC sockets.

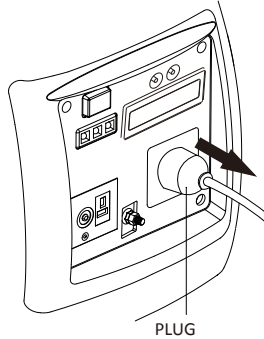

HY1000Si

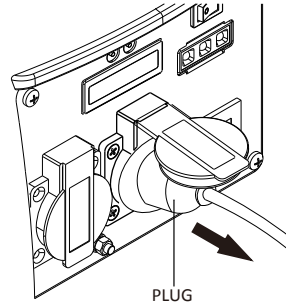

HY2000Si

7.2 Turn the engine switch to the “OFF” position.

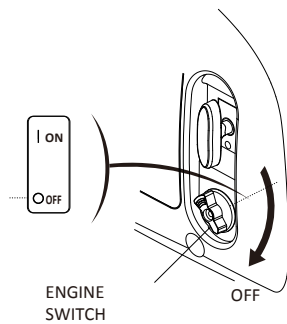

HY1000Si

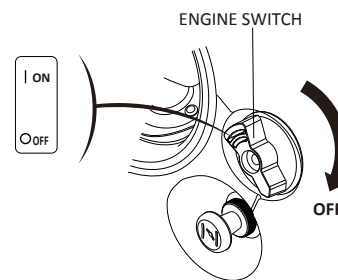

HY2000Si

NOTE

Make sure the fuel cap vent lever and engine switch are in the “OFF” position, after stopping and when transporting and storing the generator.

8.0 Maintenance.

The purpose of the maintenance schedule is to keep the generator in the best operating condition.



Stop the engine before performing any maintenance. If the engine must run, be sure the area is well ventilated. The exhaust contains poisonous carbon monoxide gas.

Only use genuine Hyundai spares to replace worn components.

Maintenance Schedule.

Regular Service Period (3)		Each use	First month or 10 hrs.	Every 3 months or 50 hrs.	Every 6 months or 100 hrs.	Every 2 years or 300 hrs.
Item						
Engine oil	Check level	⊙				
	Change		⊙		⊙	
Air cleaner	Check	⊙				
	Clean			⊙(1)		
Spark plug	Check-adjust				⊙	
Spark plug	Replace					⊙
Spark arrester					⊙	
Valve clearance	Check-adjust					⊙(2)
Combustion chamber	Clean	After every 300 hrs(2)				
Fuel tank & filter	Clean	Every year(2)				
Fuel line	Check	Every 2 years (Replace if necessary)(2)				

NOTE

(1) Service more frequently when used in dusty areas.

(2) These items should be serviced by your servicing dealer, unless you have the proper tools and are mechanically proficient. Refer to dealer for service procedures.

(3) For commercial use and/or long hours of operation you must maintain proper maintenance intervals.

8.1 Oil Change.

Drain the oil whilst the engine is still warm.

8.1.1 Loosen the maintenance cover screw, and remove the cover. 8.1.2

Remove the oil filler cap.

- 8.1.3 Drain dirty oil into a container thoroughly.
- 8.1.4 Refill the recommended oil and check the oil level.
- 8.1.5 Reinstall the oil filler cap.
- 8.1.6 Reinstall the maintenance cover and tighten the cover screw.

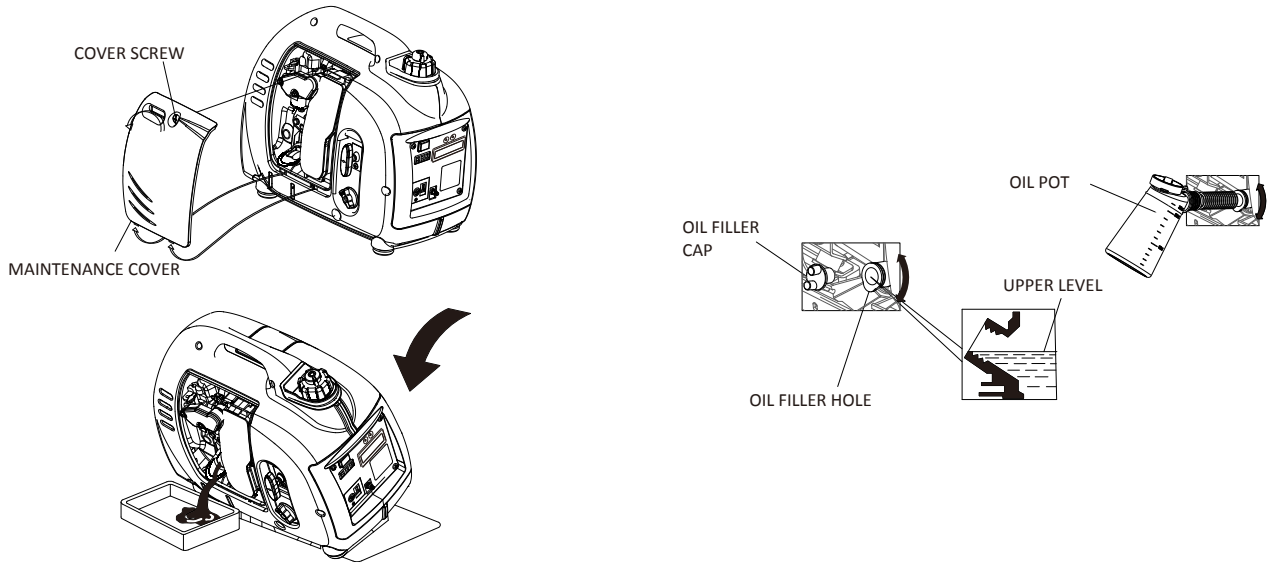

HY1000Si Oil Capacity: 0.25L
 HY2000Si Oil Capacity: 0.40L

After oil change, wash your hands with soap.

NOTE

To conform with environmental requirements, the used oil should be put into a sealed container and then be transported to an amenity recycling centre. Do not throw it into the rubbish or pour it on the ground.

8.2 Air Cleaner - Service.

A dirty air cleaner will restrict air flow into the carburetor. Clean and maintain the air cleaner regularly, especially in the extremely dusty areas.

WARNING

Do not use petrol or low ignition paint solvents for cleaning. They are flammable and explosive under certain conditions.

NOTE

Never run the generator without air cleaner or rapid engine wear may occur.

8.2.1 Loosen the two screws of the air cleaner maintenance cover, and remove the cover.

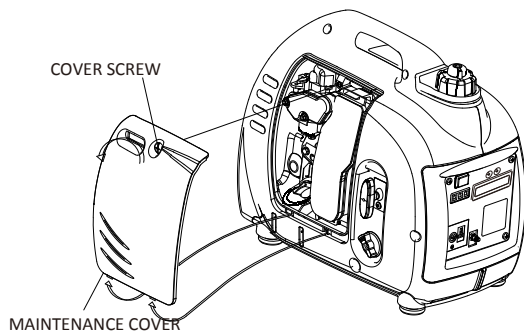

HY1000Si

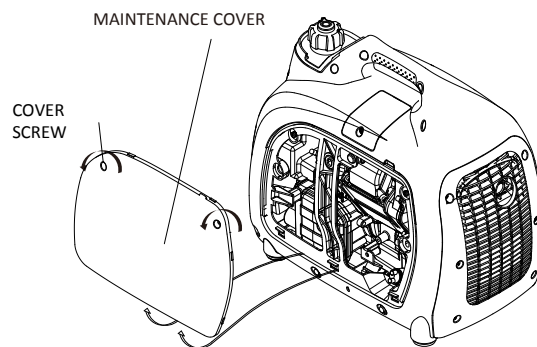

HY2000Si

8.2.2 Press down the latch tab on the top of the air cleaner, and open the air cleaner cover.

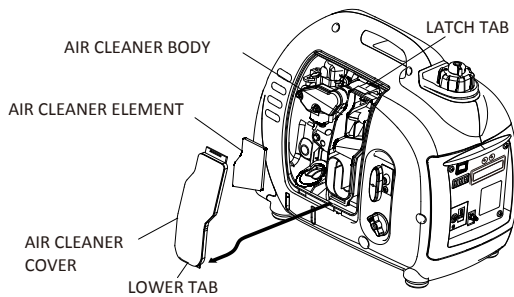

HY1000Si

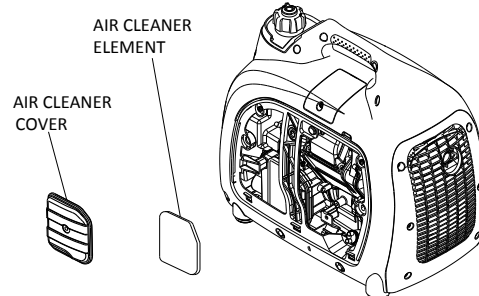

HY2000Si

8.2.3 Take out the air cleaner element, and clean it with a non-flammable or high flash point solvent, then dry it.

8.2.4 Soak the air cleaner element air filter in oil, and squeeze out the redundant oil.

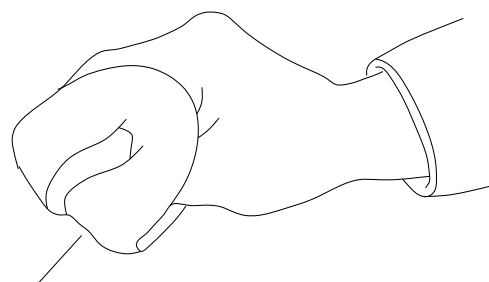

ELEMENT

8.2.5 Refit the air cleaner element and cover.

8.2.6 Refit the maintenance cover, and tighten the screws.

8.3 Spark Plug Service.

Recommended spark plug: A5RTC

Check the spark plug gap and clean the carbon deposition at the bottom of the spark plug.

8.3.1 Remove the spark plug maintenance cover.

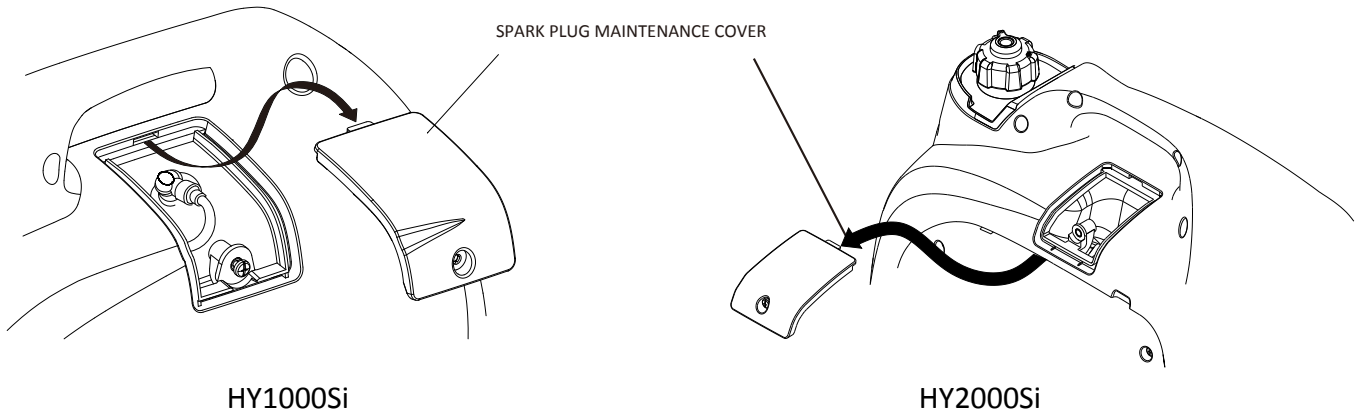

8.3.2 Take off the spark plug cap.

8.3.3 Clean the carbon deposition at the bottom of the spark plug.

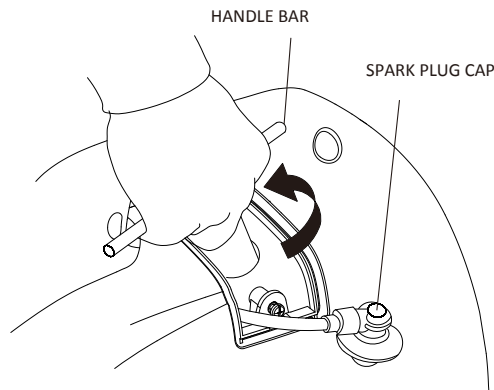

8.3.4 Take off the spark plug with the spark plug spanner.

8.3.5 Visually inspect the spark plug. Change for a new one if its insulator is cracked or chipped. Clean it with a wire brush if the spark plug is going to be re-used.

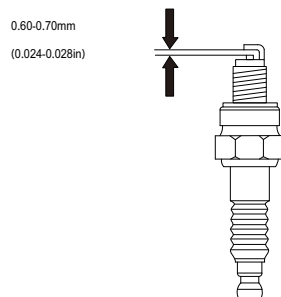

8.3.6 Measure the spark plug gap with a feeler gauge. The normal value: 0.6-0.7mm (0.024-0.028in). Adjust the gap by bending the electrode carefully.

8.3.7 Refit the spark plug carefully, by hand, to avoid cross-threading. A new spark plug should be tightened 1/2 turn with a spanner. A used spark plug should be tightened 1/8 to 1/4 turn with spanner.

8.3.8 Reinstall the spark plug cap.

8.3.9 Reinstall the spark plug maintenance cover.

NOTE

The spark plug must be securely tightened. If refitted incorrectly (i.e. cross threaded) this will damage the cylinder head.

Never use a spark plug with an improper heat range.

8.4 Spark Arrester Maintenance.



The spark arrester must be maintained every 100 hour service.

8.4.1 Remove the four/six screws, and remove the exhaust guard.

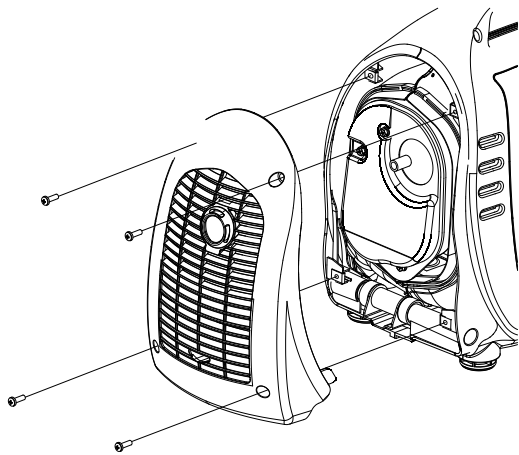

HY1000Si

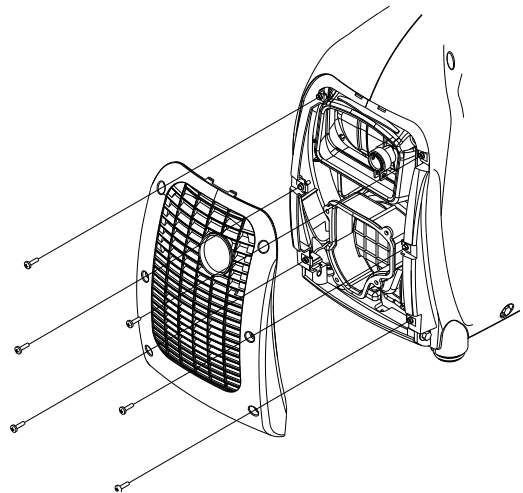

HY2000Si

8.4.2 Once the engine cools down remove the spark arrester from the exhaust.

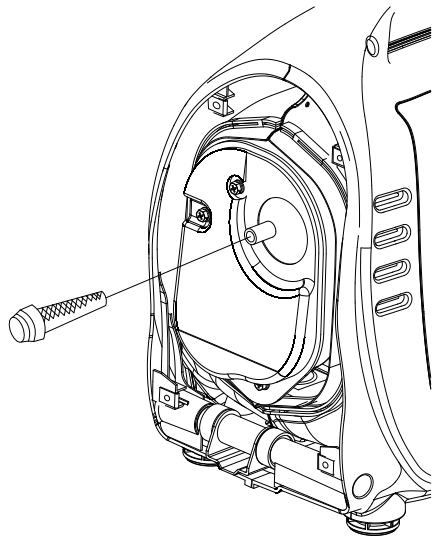

HY1000Si

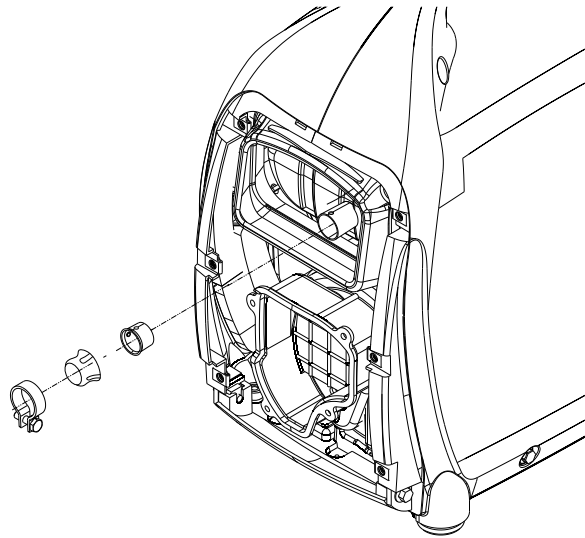

HY2000Si

8.4.3 Remove carbon deposits of the spark arrester using a wire brush. If the spark arrester is worn, replace it.

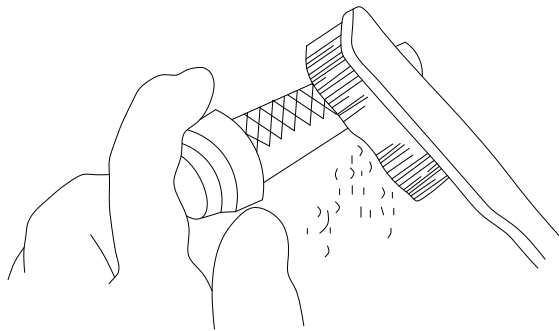

HY1000Si

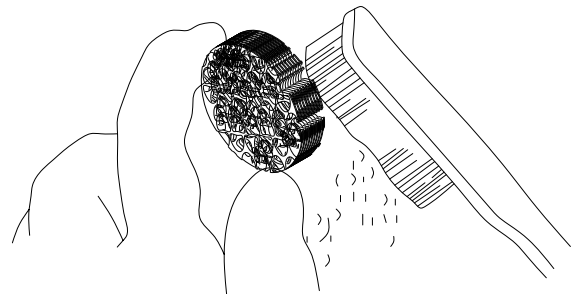

HY2000Si

8.4.4 Refit the spark arrester and exhaust guard.

9.0 Transporting/Storage.

Avoid fuel spillages during transportation or temporary storage, both the engine switch and the fuel cap vent lever should be turned to "OFF" position, and the generator should be turned off. DO NOT move a running generator, turn it off then move to new location.



Transporting the Generator.

DO NOT overfill the fuel tank.

DO NOT use the generator inside the transport vehicle. The generator should be used in an open and well ventilated area.

Avoid exposure to direct sunlight when the generator is being transported in an enclosed transport vehicle. High temperatures inside the transport vehicle could cause fuel to vaporise resulting in a possible explosion.

Drain off the fuel, when the generator is transported on rough roads.

Storing for a long period:

9.1 Make sure the storage area is clean and dry.

9.2 Drain off the fuel.



Petrol is highly explosive and flammable, keep away from naked flames and all other sources of ignition.

a. Drain off the petrol in the fuel tank, and store in a suitable container.

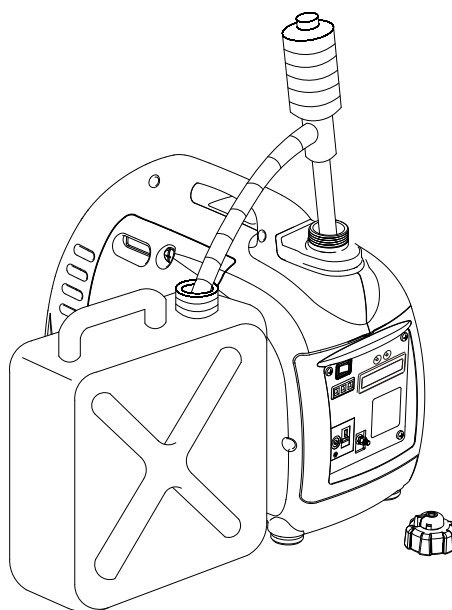

b. Turn the engine switch to "ON" position, and loosen the carburetor float bowl drain screw to discharge from inside of carburetor float bowl.

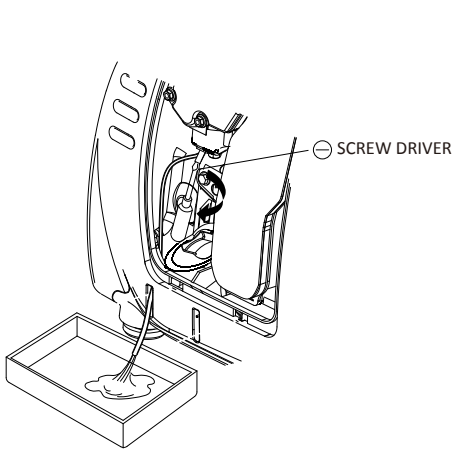

HY1000Si

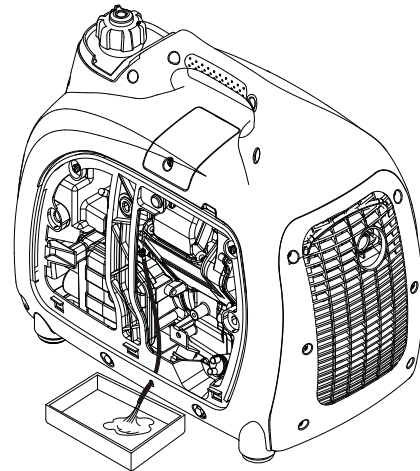

HY2000Si

c. Take off the spark plug cap, pull the recoil starter grip three or four times, discharge the petrol from the fuel pump and fuel lines.

d. Turn the engine switch to "OFF" position, and tighten the drain screw of carburetor.

e. Reinstall the spark plug cap.

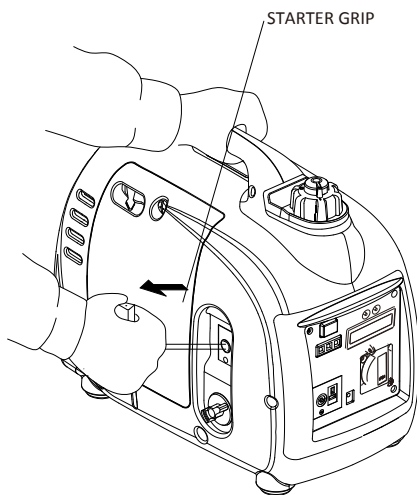

HY1000Si

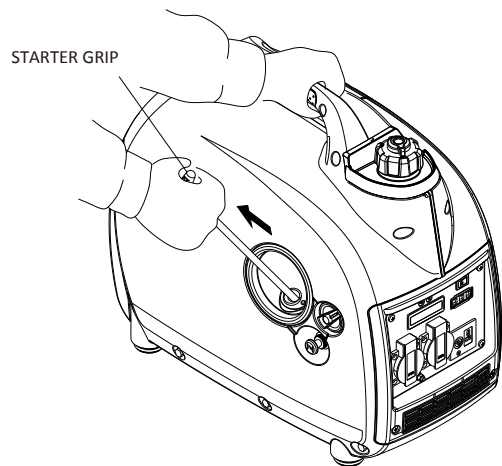

HY2000Si

9.3 Change the engine oil.

9.4 Remove the spark plug, and pour a tablespoon of clean engine oil (10~20ml) into the cylinder. Revolve the engine several times to distribute the oil, and reinstall the spark plug.

9.5 Pull the starter grip slowly until you feel resistance. At this point, the piston is coming up on its compression stroke and both the intake and exhaust valves are closed. In this position, it helps to protect the engine from internal corrosion.

10.0 Troubleshooting.

HY1000Si - Troubleshooting

When the engine cannot be started:

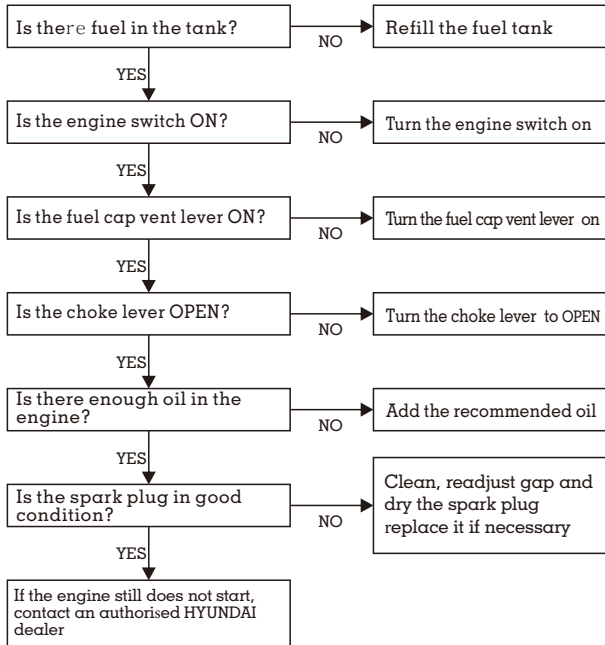

Appliance does not operate :

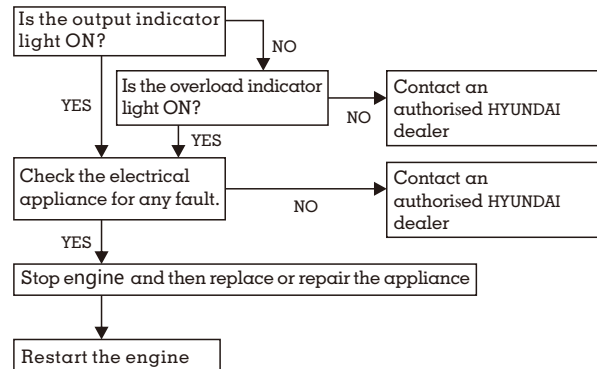

DC receptacle without any electricity :

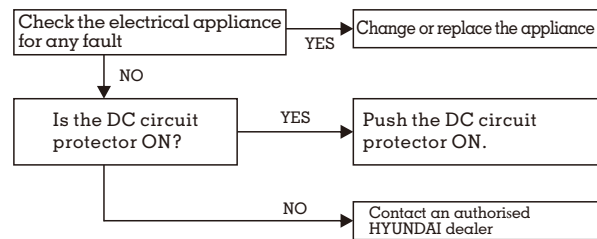

HY2000Si - Troubleshooting

When the engine cannot be started:

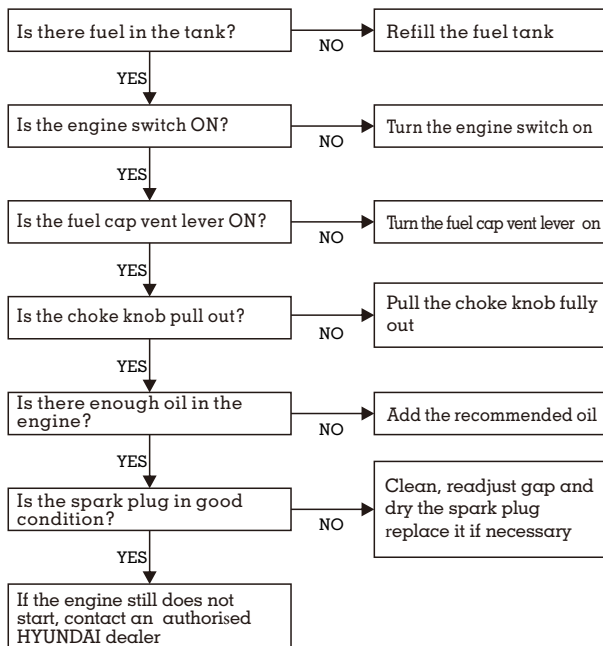

Appliance does not operate :

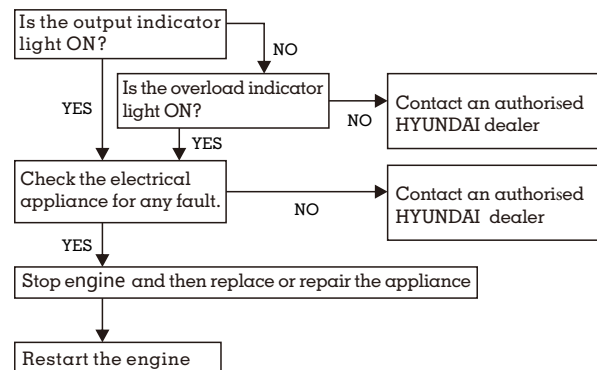

DC receptacle without any electricity :

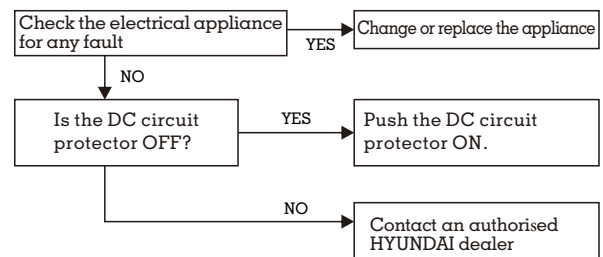

11.0 Technical Specifications

HY1000Si Technical Specifications

	Specifications	Parameters	
ENGINE	Model	HS 1200i.1	
	Type	4-stroke, overhead valve, single cylinder, forced-air cooling	
	Engine Displacement	53.2cm ³	
	Bore * Stroke	43.5mm * 35.8mm	
	Compression Ratio	1.8:5	
	Rated Speed	5500min ⁻¹	
	Ignition System	Full transistor	
	Start System	Recoil starter	
	Fuel Type	Unleaded petrol	
	Oil Capacity	0.25L	
	Oil Model	SE 15W-30	
	GENERATOR	Model	HY 1000Si
		Rated Frequency	50Hz
Rated Voltage		230V	
Rated Current		3.9A	
Rated Speed		5300min ⁻¹	
Nominal Power		0.9kW	
Maximum Power		1.0kW	

GENERATOR SET	DC Output	12V/5A
	Fuel Tank Volume	2.2L
	Continuous Running Time	6.6h
	Fuel Consumption	≤500g/(kW.h)
	Working Ambient Temperature	-20°C ~ 40°C
	Max. Altitude	1000m
	* Noise (dB/4m) L _{wA}	90
	* * Noise (dB/7m) L _{pA}	54~59
	Dimensions (L*W*H)	451mm * 242mm * 379mm
	Net Weight	14kg

Noise level is measured when the ECON Switch is turned to "ON" (☞☞☞)

* : L_{wA} shows the guaranteed sound power tested by 2000/14/EC.

* * : The noise level in "dB/7m" is the arithmetic mean value of sound press level (L_{pA}) in four directions measured 7 meters away from the generator.

The noise level may vary in different environments.

HY2000Si Technical Specifications

	Specifications	Parameters	
ENGINE	Model	149F	
	Type	4-stroke, overhead valve, single cylinder, forced-air cooling	
	Engine Displacement	79cm ³	
	Bore * Stroke	48.6mm * 43.0mm	
	Compression Ratio	1.8:7	
	Rated Power	2.3kVA/4500min ⁻¹	
	Ignition System	Full transistor	
	Start System	Recoil starter	
	Fuel Type	Unleaded petrol	
	Oil Capacity	0.41L	
	Oil Model	SE 15W-30	
	GENERATOR	Model	HY 2000Si
		Rated Frequency	50Hz
Rated Voltage		230V	
Rated Current		7.0A	
Rated Speed		4500min ⁻¹	
Nominal Power		1.6kW	
Maximum Power		2.0kW	

OTHER SPECIFICATIONS	DC Output	12V/5A
	Fuel Tank Volume	3.8L
	Continuous Running Time	8.0h
	Fuel Consumption	≤500g/(kW.h)
	Working Ambient Temperature	-20°C ~ 40°C
	Max. Altitude	1000m
	* Noise L _{wA}	90dB/4m
	* * Noise L _{pA}	54~59dB/7m
	Dimensions (L*W*H)	510mm * 455mm * 280mm
	Net Weight	20kg

Noise level is measured when the ECON Switch is turned to "ON" (☞☞☞)

* : L_{wA} shows the guaranteed sound power tested by 2000/14/EC.

* * : The noise level in "dB/7m" is the arithmetic mean value of sound press level (L_{pA}) in four directions measured 7 meters away from the generator.

The noise level may vary in different environments.

HY2000Si-115 Technical Specifications

	Specifications	Parameters	
ENGINE	Model	149F	
	Type	4-stroke, overhead valve, single cylinder, forced-air cooling	
	Engine Displacement	79cm ³	
	Bore*Stroke	48.6mm*43.0mm	
	Compression Ratio	1.8:7	
	Rated Power	2.3kVA/4500min ⁻¹	
	Ignition System	Full transistor	
	Start System	Recoil starter	
	Fuel Type	Unleaded petrol	
	Oil Capacity	0.41L	
	Oil Model	SE 15W-30	
	GENERATOR	Model	HY 2000Si
		Rated Frequency	50Hz
Rated Voltage		115V	
Rated Current		17.4A	
Rated Speed		4500min ⁻¹	
Nominal Power		1.6kW	
Maximum Power		2.0kW	

OTHER SPECIFICATIONS	DC Output	12V/5A
	Fuel Tank Volume	3.8L
	Continuous Running Time	8.0h
	Fuel Consumption	≤500g/(kW.h)
	Working Ambient Temperature	-20°C~40°C
	Max. Altitude	1000m
	* Noise L _{wA}	90dB/4m
	* * Noise L _{pA}	54~59dB/7m
	Dimensions (L*W*H)	510mm*455mm*280mm
	Net Weight	20kg

Noise level is measured when the ECON Switch is turned to "ON" (ON/OFF)

* : L_{wA} shows the guaranteed sound power tested by 2000/14/EC.

* * : The noise level in "dB/7m" is the arithmetic mean value of sound press level (L_{pA}) in four directions measured 7 meters away from the generator.

The noise level may vary in different environments.

12.0 Wiring Diagrams.

HY1000Si

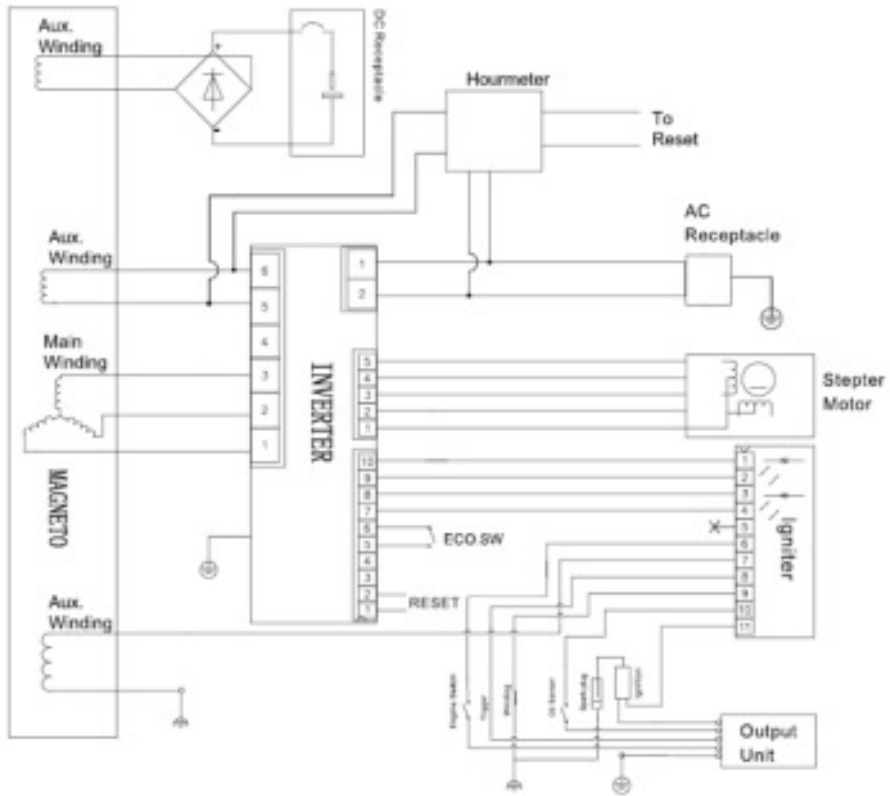

HY2000Si

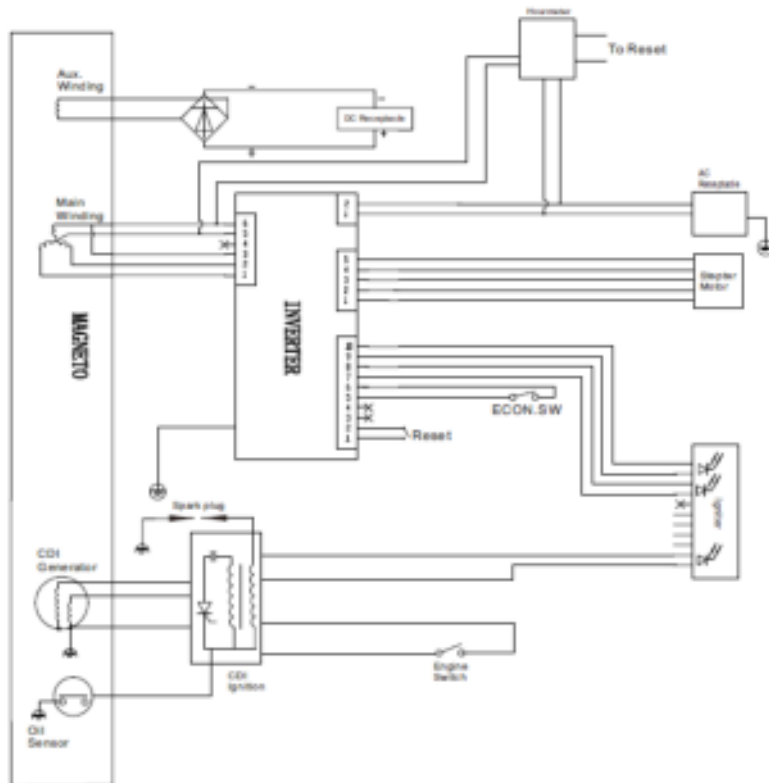

13.0 Appendix.

13.1 EC Declaration of Conformity

The generator complies with below the technical requirements:

- 2006/42/EC Machinery Safety. EN12601:2010 Reciprocating internal combustion engine driven generating sets safety.
- 2006/95/EC Low Voltage Electrical Equipment.
- 2004/108/EC Electromagnetic Compatibility.
- 97/68/EC (with amendment 2010/26/EU) Engine Emission of Pollutants.
- 2000/14/EC Outdoor Noise Directive.

EC DECLARATION OF CONFORMITY

The undersigned, as authorised by: **Genpower Ltd**

Declares that the following equipment manufactured under licence by **Hyundai Korea**

Conforms to the Directive: -
2000/14/EC (as amended)

Of the European Parliament and of the council on the approximation of the laws of the Member States relating to the noise emission in the environment by equipment for use outdoors.

Equipment Category: **Generator**
Product Name/Model: **Petrol – HY1000Si 2015
Petrol – HY2000Si 2015**
Type/Serial No: **Petrol Inverter generator**
The technical documentation is kept by: **Kevin Stanley, Genpower Ltd,
Isaac Way, London Road, Pembroke Dock,
SA72 4RW, United Kingdom.**
Electric power: **1.0 kW, 2.0 kW**

The conformity assessment procedure followed was in accordance with annex VI of the Directive.

Notified Body: **The Société Nationale de Certification et d'Homologation
s.à r.l. (SNCH) Luxembourg**
Certificate Number: **No. 0499**
Measured Sound Power Level: **HY1000Si 2015 88 dB (A) - HY1000Si 2015 88 dB (A)**
Guaranteed Sound Power Level: **HY2000Si 2015 90 dB (A) - HY2000Si 2015 90 dB (A)**

A copy of this certificate has been submitted to the European Commission and to EU Member State United Kingdom.

Place of Declaration: **Pembroke Dock, SA72 4RW**
Date: **15th April 2015**
Signed by: **Kevin Stanley**
Position in Company: **Product Manager**

Name and address of manufacturer or Authorised representative:



**Genpower Ltd, Isaac Way, London Road,
Pembroke Dock, SA72 4RW, United Kingdom.**

13.2 Environmental Corrections.

The standard condition of rated power output;

Altitude; 0 metres
 Ambient Temperature 25 °C
 Relative humidity; 1%

Altitude (m)	Ambient temperature°C				
	25	30	35	40	45
0	1	0.98	0.96	0.93	0.90
500	0.93	0.91	0.89	0.87	0.84
1000	0.87	0.85	0.82	0.80	0.78
2000	0.75	0.73	0.71	0.69	0.66
3000	0.64	0.62	0.60	0.58	0.56
4000	0.54	0.52	0.50	0.48	0.46

NOTE

Relative humidity 60% correction factor C- 0.01 ;
 Relative humidity 80% correction factor C -0.02 ;
 Relative humidity 90% correction factor C- 0.03 ;
 Relative humidity 100% correction factor C- 0.04 ;

Example :

Rated power (P) 1.6kVA generator (Altitude: 1000m) Ambient temperature: 35°C,
relative humidity: 80%

$$P=P_n * (C-0.02) = 1.6*(0.82-0.02) = 1.28\text{kVA}$$

13.3 Noise and Access.

Noise emission measure according to ISO 8528-10, EN ISO 3744, European Directive 2000/14/EC with amendment 2005/88/EC

Model of Generator Set:	HY1000Si	HY2000Si
Guaranteed Sound Power Level:	90dB(A)	90dB(A)
Measurement Uncertainty K:	1.7 dB(A)	1.7 dB(A)

The quoted figures are emission levels and are not necessarily safe working levels. Whilst there is a correlation between the emission and exposure levels, this cannot be used reliably to determine whether or not further precautions are required. Factors that influence the actual level of exposure of work-force include the characteristics of the work room, the other sources of noise, etc. i.e. the number of machines and other adjacent processes, and the length of time for which an operator is exposed to the noise. Also the permissible exposure level can vary from country. This information, however, will enable the user of the machine to make a better evaluation of the hazard and risk.

14.0 Consumer Information.

Consumer Service Information

Service dealers are trained professionally. They should be able to answer any questions you have. If the dealer does not solve your problems, please discuss them with the manager of the dealer. Most of your problems are solved in this way. If you are dissatisfied with the decision of the manager of the dealer, contact the Customer Relations Department of Genpower Ltd.

NOTES

NOTES



GENPOWER LTD

Isaac Way, Pembroke Dock, Pembrokeshire, UK, SA72 4RW

T: +44 (0) 1646687880

F: +44 (0) 1646 686198

E: sales@genpower.co.uk

www.hyundaipowerequipment.co.uk