

Plus Safe TUB / LID

Child Resistant Packaging for liquid and powder pouches

PRODUCT DATASHEET

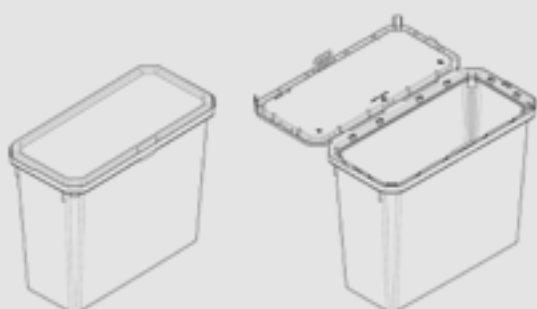

**Bergen
Plastics**

WHAT WE DO?

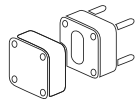

**INJECTION
MOULDING**

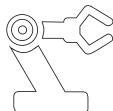

**AUTOMATED
ROBOTIC
ASSEMBLY**



**QUALITY
MANAGEMENT**



**PROJECT
MANAGEMENT**



LOGISTICS

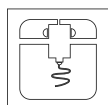

PROTOTYPING

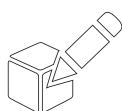

**INDUSTRIAL
DESIGN**



ENGINEERING

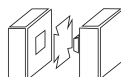

**IN-MOULD
LABELLING**



**LAB
SERVICES**

ABOUT BERGEN PLASTICS AS

Bergen Plastics is a leading European supplier of cost-effective thin wall packaging. We are the European market leader of child safe packaging. Our R&D team is continuously working to develop the future child safe packaging solutions. We are customer oriented in our thinking, sustainable in our actions and cost focused in our way of manufacturing. We develop product solutions and manufacture large quantities of products for leading multinational enterprises.

ENVIRONMENTAL ACCOUNTABILITY

The combination of low energy costs and the greenest energy in Europe makes Bergen Plastics the first choice among European customers focusing on sustainability.

CHARACTERISTICS OF PLUS SAFE DESIGN

- good combination between weight and strength
- available in standard colours
- max label facing for container and lid
- designed for automatic filling lines
- CRP-approved
- available in large quantities
- sustainable use of material and production process

CONTACT



BERGEN PLASTICS AS
SANDBREKKEVEGEN 85
5225 NESTTUN, BERGEN
PHONE: (+47)55925720
WWW.BERGEN-PLASTICS.NO
POST@BERGEN-PLASTICS.NO

Plus Safe Series™

IDEA DESCRIPTION



OPENING CLOSING FUNCTION

The *Plus Safe* is the result of dedicated research and development by Bergen Plastics, yielding a packaging certified according to ISO8317; with a high-level of child-resistance, that is also convenient for the customer. The interface between tub and lid makes it difficult for children to gain access to the contents, but the contents are still easily accessible for adults following the simple opening instructions.

INTRODUCTION TO SAFE SERIES

Bergen Plastics holds the market leader position in Europe concerning special packaging focusing on children`s safety. We offer offer the *Plus Safe™* container and lid series; a new benchmark in child-resistant packaging (CRP). This packaging has been tested and approved in accordance with ISO 8317.

OPENING INSTRUCTION

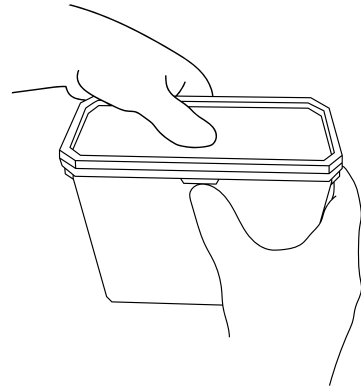

1. Press the lid down towards the surface.

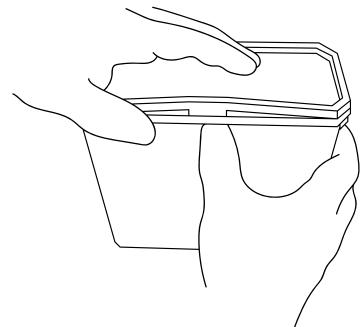

2. Push the main clip in towards the tub and upwards.

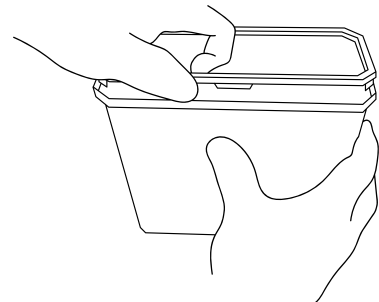

3. Grab the exposed lid and open along the path.

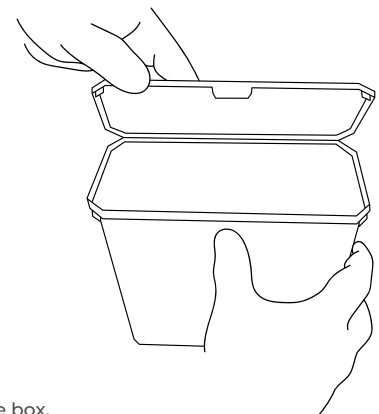

4. Open the box.

Plus Safe TUB

SPECIFICATION

SIZE

The *Plus Safe™* tub is available in three different sizes (110, 140 and 150). There is one lid option, which fits all 3 tub versions.

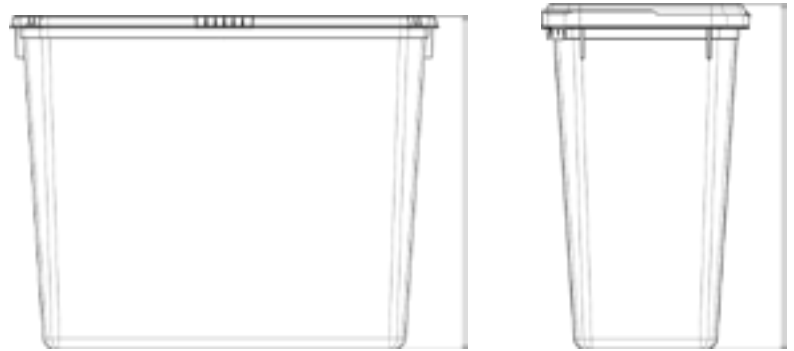

150 mm (156 mm with *Plus Safe* LID)

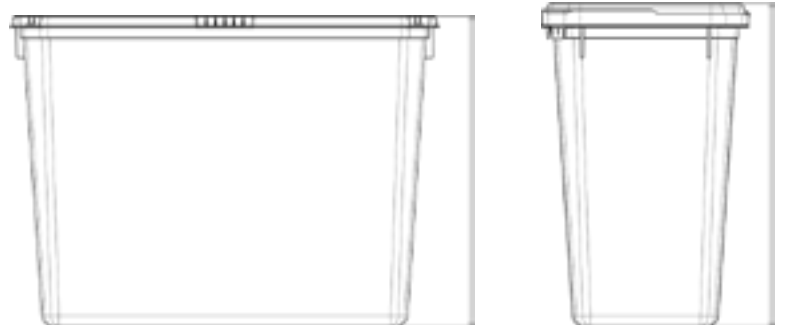

140 mm (146 mm with *Plus Safe* LID)



110 mm (116 mm with *Plus Safe* LID)

Plus Safe TUB

SPECIFICATION



Plus Safe TUB 110 mm

Plus Safe TUB 140 mm

Plus Safe TUB 150 mm

ARTICLE NAME

600001

600002

600003

ARTICLE NUMBER

POLYPROPYLENE (PP)

POLYPROPYLENE (PP)

POLYPROPYLENE (PP)

MATERIAL

any color possible

any color possible

any color possible

COLOUR

43,1 g ± 2 g

55,8 g ± 2 g

58,4 ± 2 g

WEIGHT

1.25 L

L

1.7 L

VOLUME



Plus Safe LID



Plus Safe LID



Plus Safe LID

LID

3360 psc. pr. box *
3360 psc. pr. pallet *

psc. pr. box *
psc. pr. pallet *

2208 psc. pr. box *
2208 psc. pr. pallet *

REMARKS

DIN 16901

DIN 16901

DIN 16901

TOLERANCES

ISO-8317 - CRP APPROVED

ISO-8317 - CRP APPROVED

ISO-8317 - CRP APPROVED

CERTIFICATE

* can be updated without notice

Plus Safe TUB

SPECIFICATION

ABOUT TOLERANCE

Any minor visual or technical defect, not impeding the functionality and general usage of the product, is deemed acceptable. This includes, but is not limited to, minor flash along the parting lines, minor unfilled areas, freezemarks, scratches, color variation, warping and bulging. It is the customer's responsibility to validate and decide if the packaging is suitable for their intended use.

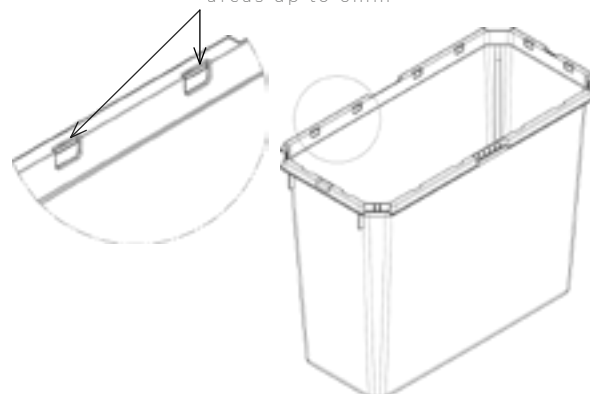
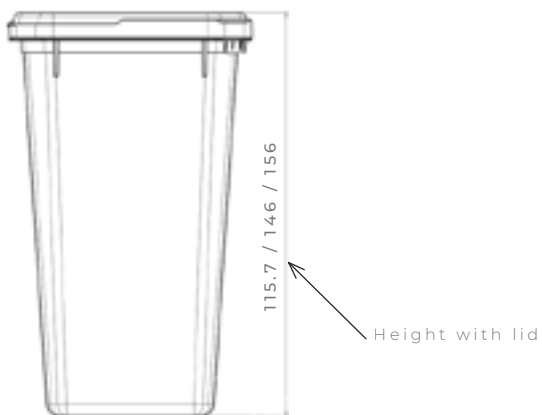
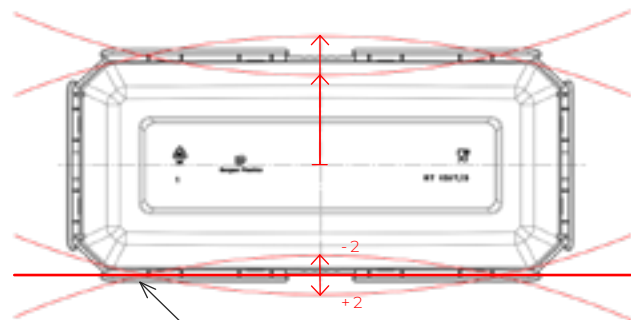
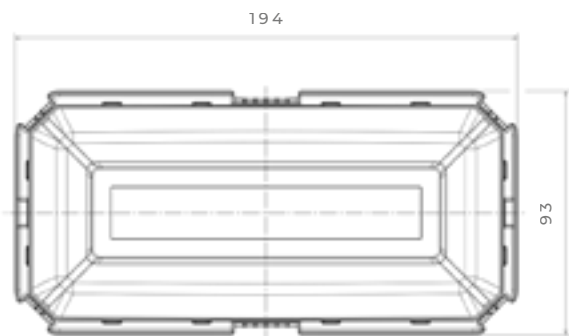
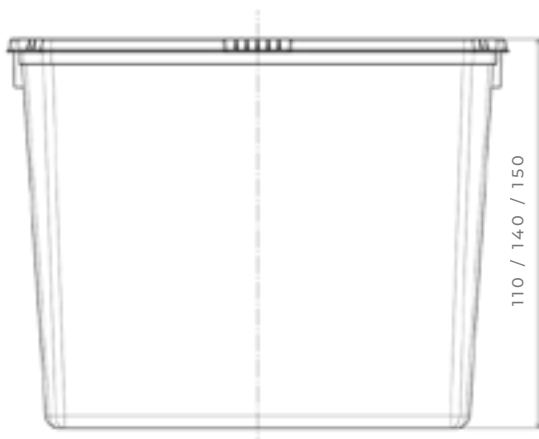

Plus Safe LID

SPECIFICATION

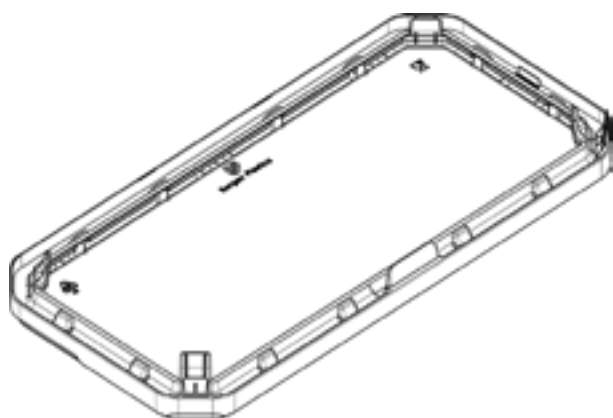
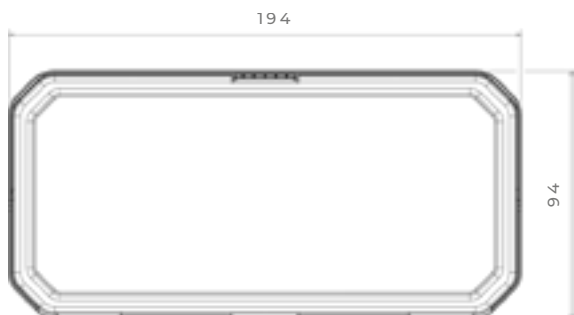

ABOUT TOLERANCE

The lid have two injection points in order to ease the filling during production. The injection points can be on both sides of the lids. Injection points can not be removed. The lidframe is

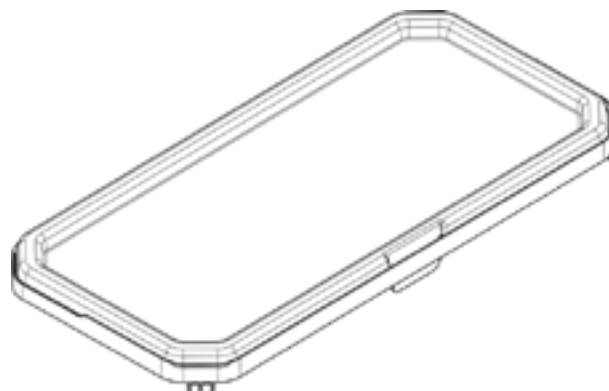

Plus Safe LID

ARTICLE NAME _____

600004

ARTICLE NUMBER _____

POLYPROPYLENE (PP)

MATERIAL _____

any color possible

COLOUR _____

20 ± 1 G

WEIGHT _____

420 psc. pr. box
8400 psc. pr. pallet

REMARKS _____

DIN 16901

TOLERANCES _____

ISO-8317 - CRP APPROVED

CERTIFICATE _____



Plus Safe TUB 600001, 600002, 600003

TUB _____

designed to lock onto the tub. Due to the hinges on the lid there can be some deformations on the frame. As long as the lid fits to the tub frame it is acceptable. Size and tolerances according to DIN 16901.

Safe Series™

LABELING



CONTACT



BERGEN PLASTICS AS
SANDBREKKEVEGEN 85
5225 NESTTUN, BERGEN
PHONE: (+47)55925720
WWW.BERGEN-PLASTICS.NO
POST@BERGEN-PLASTICS.NO

ABOUT COLORS



The *Safe Series™* can be manufactured and delivered in all colours requested by our customers. Prior to start of production our customers have to approve colour samples. There can be smaller difference in tolerances and measures related to colours. As our customer you are responsible to control and approve that colors are acceptable and approved. Colors can raise additional costs.

SIZE

The *Plus Safe™* TUB is available in different sizes (110/140/150) with *Plus Safe™* LID.

LABEL RECOMMENDATIONS

Plus Safe™ has been designed for optional label spacing.

Recommended max. dimensions for the conventional lid label.

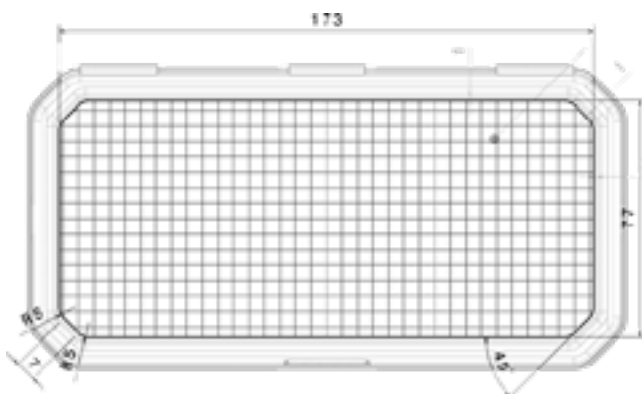
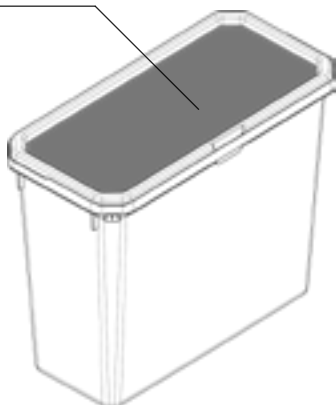

Recommended max. dimensions for the tub label (150 mm).

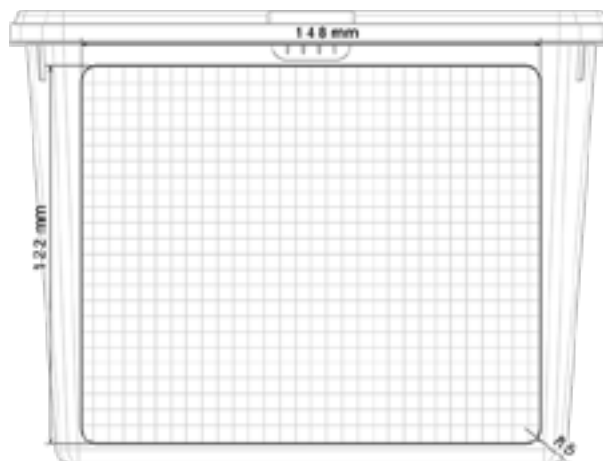
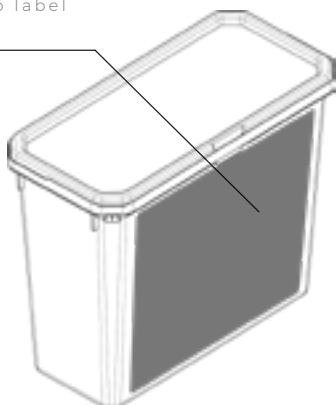

Safe Series™

RANGE OF CHOICES



DISCLAIMER

Before using a product sold by a Bergen Plastics company, user should make their own independent determination that the product is suitable for the intended use and can be used safely and legally. Seller makes no warranty. Express or implied (including any warranty of merchantability or fitness for particular purpose or any warranty) other than as separately agreed to by the parties in a contract.

In addition to the above, Bergen Plastics may further prohibit or restrict the use of its products in certain applications or markets. For further information, please contact a Bergen Plastics representative.

CONTACT



BERGEN PLASTICS AS
SANDBREKKEVEGEN 85
5225 NESTTUN, BERGEN
PHONE: (+47) 55925720
WWW.BERGEN-PLASTICS.NO
POST@BERGEN-PLASTICS.NO