

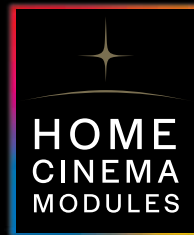

BENCHMARK ^{AV} DISTRIBUTION

Screens, speakers, amps, subwoofers, players, projectors, acoustic treatment, ...
Benchmark AV is your reference



Content

4	About
6	ATI - American muscle
8	CHIEF - Installer inspired
10	Da-Lite - Reflecting your vision
12	Dreamscreen - we want to cineamaze you
14	Green Glue - Noiseproof your life
16	Grimani Systems - Spellbinding home entertainment
18	Home Cinema Modules - Just sit back..
20	JVC - Go further, be the first
22	Luxul - Reliable network, reliable system
24	madVR - Every pixel counts
26	Mag Audio Theatron - Experience real cinema at home
28	Magnetar - World-class acoustics
30	Middle Atlantic - What great systems are built on
32	Musical Fidelity - Power amplifier
34	Panamorph - We bring cinema home
36	Prismasonic - Anamorphic lenses
38	R_volution - Your favorite movies, tv shows and concerts, all in one place
40	RBH - Redefining the way you experience sound
42	Reavon - Universal 4K HD Blu-Ray players
44	Sanus - Affordable racks and furniture
46	Screen Innovations - Beautiful Lifestyle Innovations
48	Senor - The best solution for your home
50	Sofabaton - Symplify your Entertainment-Life
52	Sonitus - World-class acoustics
54	SVS - Sound R Evolution

A real movie
theater in your
home...
It's possible



About our movie room

Audiocom - UDP-205 Référence

Audioquest

Chief - RPMA 281

CineSeats - Roma Elite and Selena

Control4

Emotiva - RMC-1

Grimani Systems - Rixos speakers and Sigma subwoofers

JVC - DLA NZ9

madVR Envy Extreme

Middle Atlantic Rack

Screen Innovations - Transformer

Trinnov - Altitude 32

Sonitus Acoustics

Zappiti - NAS RIP SE 4K HDR and Signature player

Video Player and UHD Blu-Ray player

Cables

Projector mount

Movie theater seats

Automation

Audio processor

Speakers, subwoofers and amplifiers

Projector

Video processor

Rackmount for the electronics

Projection screen

Audio processor

Acoustic treatment

Video server and player

About us

Benchmark AV started in 2017 with the distribution of a few brands like OPPO, Audiocom, Zappiti and SVS.

And now, in 2021, we have 20 brands imported from all over the world (America, Croatia, France,...) that we distribute around the Benelux !

But we want to be more than just a simple AV distributor. We want to help you carry out your every project.

Dear resellers, welcome to Benchmark AV



ATI: American muscle

Maximum Performance For more than three decades, designer/engineer Morris Kessler has created audio/video products with a simple goal in mind: delivering maximum performance and reliability. In his products, you will find no gratuitous features or needless ornamentation. But everywhere you look, you will find design touches that improve sound quality and increase dependability.

ATI provides solutions to virtually any audio/video situation, from basic stereo or whole-house audio installations to the most robust home theater set-up. Their products are built 100 percent to our specifications, and they monitor every aspect of the quality-control process ourselves. ATI products are simply the best value in the audio industry. Unmatched dependability and stunning sound quality is what you can expect.

ATI AT540NC Series

Designed and built on the musical and highly efficient Hypex N-Core® amplifier technology, the AT54XNC Series amplifiers deliver a substantial 500 watts per channel. By bridging each pair of amplifier output modules, output power is increased by 2.5x for greater headroom, loudspeaker drive and sonic impact. Available in 4 models from 1 to 4 channels, the AT54XNC Series offers efficient amplifier performance and value. High current toroidal transformers, a standard for all ATI power amplifiers, provide clean power and performance stability.



ATI AT1820 Series

Amplifier Technologies AT1820 Series amplifiers meet the needs of home audio systems from two channel to home theater. Simple and straightforward in design, the ATI AT1820 series offers models from 2 to 7 channels per chassis. AT1820 Series amps deliver 200 watts per channel to 8 ohms and 300 watts per channel to 4 ohms and offer tremendous value, performance, and reliability.





ATI AT520NC Series

- Amplifier Class D
- 200 Watts/channel @ 8Ω
- 2 to 8 channels



ATI AT540NC Series

- Amplifier Class D
- 500 Watts/channel @ 8Ω
- 1 to 4 channels



ATI AT1820 Series

- Amplifier Class AB
- 200 Watts/channel @ 8Ω
- 2 to 7 channels



ATI AT3300 Series

- Amplifier Class AB
- 330 Watts/channel @ 8Ω
- 2 to 8 channels



ATI AT4000 Series

- Amplifier Class AB
- 200 Watts/channel @ 8Ω
- 2 to 7 channels



ATI AT6000 Series

- Amplifier Class D
- 300 Watts/channel @ 8Ω
- 2 to 7 channels

CHIEF: Installer inspired



Committed to responding to industry needs in the commercial and residential markets, Chief offers a complete line of mounts, racks and accessories for TVs, displays, projectors and other AV components.

Tools:

If you need a specific mount for a projector, the MountFinder is the best tool to find the perfect mount ! All the tools are available on the CHIEF website !



No need to measure or calculate. Our MountFinder will help you select the mount that will best fit your TV.

MOUNTFINDER

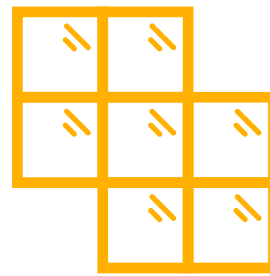

Design and order the parts necessary for TiLED™ LED Video Wall Mounting Configurations.

TILED™ LED VIDEO WALL CONFIGURATOR



Build and order the parts necessary to meet your exact application requirements.

FUSION MULTI-DISPLAY CONFIGURATOR

Some of their bests products



RPMA 281 (OPTIMISED FOR JVC PROJECTORS)
USED IN OUR REFERENCE MOVIE ROOM

The Custom RPA Elite Projector Mounts can be ordered to fit any projector for a quick and easy install.

- Microzone Adjustments make projector registration fast and precise (including flush mount installations)
- Centris Technology enables effortless fingertip positioning and self-adjusts to support different projector weights
- Quick connect/disconnect for convenient lamp and filter access on most projectors
- Maintains registration when disconnected and doesn't affect preset adjustments



CMS006
EXTENSION COLUMN

Save installation time and maximize security with these fixed columns.

- Aluminum extension column features easy installation and maximum strength
- Consists of 1.5" NPT column, threaded on both ends
- Use in combination with any Chief 1.5" NPT ceiling plate or other accessory
- TAA Compliant



TS525TU - WALLMOUNTS FOR TV 42" TO 75"

A lightweight, low-profile full-motion wall display mount for TVs 42-75". Easily installs with one person by mounting the top rail and sliding on the assembly.

- **Ultra Low Profile** Sleek design collapses to 1.5" (38 mm), providing an ultra-low profile for all types of TVs, including LED, LCD and Plasma
- **Extends up to 25" (635 mm)** Full extension maximizes viewing potential
- **Centris™ low-profile tilt** Provides up to 15° of effortless fingertip tilt to achieve optimal viewing angles
- **Centerless™ Lateral Shift** Post-installation lateral shift allows up to 16" (406 mm) of adjustment for limitless centering capability
- **Integrated Cable Management** Enclosed, tool-free cable covers and a wideopen wall plate make it easy to route power and signal cables, and connect to the wall for a seamless installation



SMART-LIFT - AUTOMATED PROJECTOR MOUNT

The SL236 automated projector mount lift provides extended travel with exceptionally smooth and quiet movement and is a great option for suspended and finished ceilings in homes and corporate offices.

Must order SLB interface bracket separately

Use Chief's MountFinder to determine which model number matches your specific projector



Da-Lite: Reflecting your vision



Future focused technology and innovations

Da-Lite keeps track of what's going in the AV market and develops projection solutions that match current and future projector technologies. The engineering of the HD Progressive line of projection surfaces is a great example of this. The features of these projection surfaces are developed to match the specific requirements of high resolution projection, like preventing microscopic variances in the base material for pixel preservation. The Da-Lite Dry Erase Screens also matches the latest technology for projection with touch interaction and Ultra Short Throw projection.

World-class customer service and project support

The multi-lingual Da-Lite field and inside sales teams are trained to support your project. We can assist with making the right choice for a projection screen that matches the projector capabilities for the optimal end result. Our customer service team will reply quickly and accurately to your questions and quote requests every day.

Extensive and quick customisation

Da-Lite projection screens are built to order from start to finish in-house to ensure a high level of flexibility. When your order comes in, we almost instantly start the production of your projection screen, and customizing can be done just as quick. Because of this, we are able to design and manufacture custom projection screens to match every challenging project.

Tools

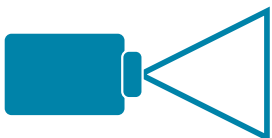

Based on Your project plans, Luxul engineers will provide a custom network design.

PROJECTOR CALCULATOR



The certified design will provide you with a list of both required and optional equipment.

PROJECTION SCREEN
ACADEMY



HomeScreen Deluxe

The HomeScreen Deluxe is a fixed frame screen with black velvet frame as well as the latest technology in projection surfaces designed for 4K and Ultra HD to maximize the technology of your projector. The larger standard black frame gives the eye a point of reference.

- Luxurious, high quality fixed frame screen with a black velvet frame finish and a wide selection of screen surfaces.
- The flat aluminium frame for the HomeScreen Deluxe has a black velvet cover, which eliminates reflection and serves to absorb projected light.
- The frame (8 cm wide and 3 cm deep) features a beveled edge, reducing shadowing in the viewing area.
- The projection screen surface is attached to the rear of the screen with Velcro®.
- The frame and projection screen surface can be custom made to project requirements.
- The projection surface is exceptionally flat, making it suitable for all types of data and video projection.
- The frame is easy to mount with the supplied mounting brackets.



Tensioned DescenderPro

The DescenderPro is a ceiling recessed-projection screen that combines new installation features with a new motorized ALR surface option in addition to the high resolution HD Progressive materials. One of the most noticeable new features is the possibility to just click-in the entire roller that includes the motor and screen surface after installation of the case. The new case design offers a clean finish without gaps or visible screws, after attaching the bottom plate to the case.

- The most comprehensive ceiling recessed projection screen in the market with tab-tensioned system for a perfectly flat screen surface. Redesigned and improved for ease of installation and a clean finish.
- Easy Serviceability System – the roller with motor and screen surface can be 'clicked' in-place for easy installation and servicing. Once installed, the motor and screen surface remain accessible.
- After installation, the closure panel and side-caps align for a clean finish without gaps.
- Choose between the unique 2-step installation or use direct 1-step installation-option.
- The tab-tensioning system will keep the projection surface under a constant tensioning for a perfectly flat viewing area.
- The case and the projection screen surface can be made to exactly the right size and the case is available in any colour for optimal integration into any interior.
- The Tensioned DescenderPro is supplied with a wall switch.
- The projection surface is extremely flat, making it suitable for all types of data and video projection.

Dreamscreen: We want to cineamaze you

One of their largest breakthroughs occurred in 2013/2014 when they discovered the basis of their most advanced sound transparent fabric ever; the UltraHD V5. The basis used to produce this groundbreaking product is now patent pending, and their application has been accepted and recommended by the International PCT at Level II and is now forwarded to local markets, starting with the US and the EU.

Currently they're developing new items for sound-proofing your room, including U-boats - basically rubber «feet» that you place your floor-studs on, as well as rubber-clips used on walls and ceilings for detached metal-stud-attachment. Floating your floor and decoupling your walls and ceiling with as little loss of room-volume as possible is indeed one of the most important elements when sound-proofing a room, and thus we found the need of improving some of the items available out there somewhat as well as reducing customers cost.

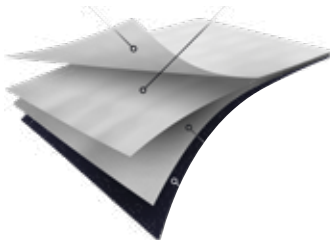

ULTRAWEAVE 7

Utilise their patented multiple layered principle in order to increase gain levels to the absolute possible maximum while still retaining the ultra matte characteristics of that of a perfectly performing unity gain type of screen. At the same time our goal was to keep the acoustical transparency at the highest possible level achieving this.

Our solution to this challenge was adding yet another custom designed reflective layer, increasing the amount of layers from 3 to 4. One front ultra-fine woven and three layers of knitted fabrics in different layouts and configurations. Everything is custom made down to the thread diameter and carefully tuned appearance of each layer.



TEXTILESHIELD
Repels liquid, fat and
solid stains



FLEXIBAFFLE V2

The FlexiBaffle V2 is a brand new concept where flexible steel studs allows you to build custom walls from 2m to 4m in width and depth from 20cm to 40cm without having to cut one single stud! The steel studs consist of two parts that is easily locked down to its required dimension using a pop nail tool.

This kit includes:

- Selection of flexible steel studs to make out any custom wall from 2-4m in width and 20-50cm in depth
- Pop nail tool as well as nails
- ProSilence rubber U-boats to decouple from floor
- ProSilence rubber clips to decouple from wall
- Fabric attachment profiles
- Black fabric

In addition, you will need the following components, sold separately:

- Fiber Gypsum or MDF to cover the front wall
- 30-50mm acoustical panels to cover the front wall

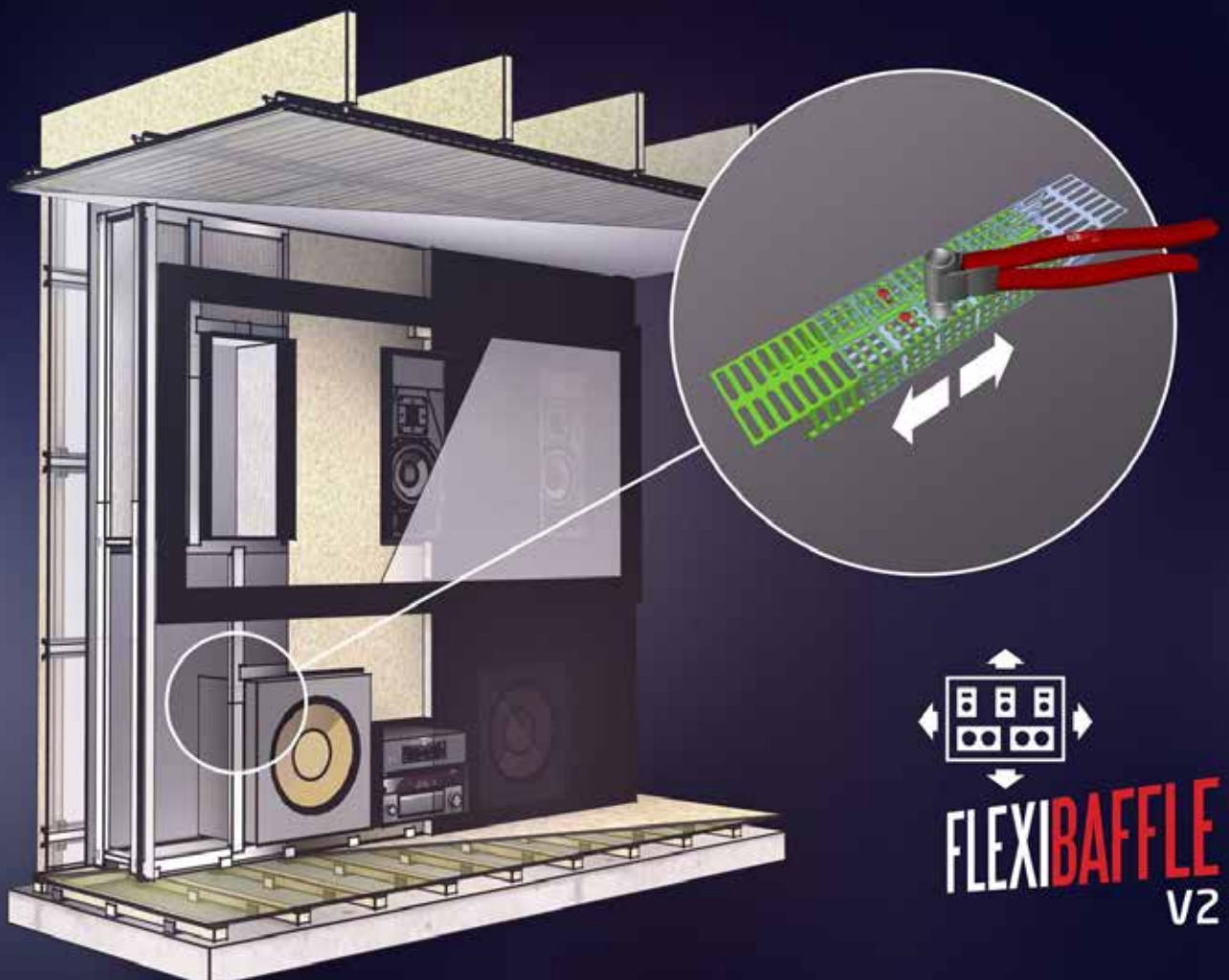

Green Glue: Noiseproof your life



Soundproofing with Green Glue Noiseproofing Compound is one of the most rewarding investments you can make in your home or business. Unwanted noise is everywhere, from footsteps stomping across the floor above, a television blaring in the next room, or traffic whizzing by your house. In a world where we are constantly distracted and forced to multi-task, it's no wonder that most of us treat unwanted noise as a form of pollution.

The range of Green Glue Noiseproofing Solutions lets you enjoy the benefits of quieter living and reduced fatigue and stress. It also raises the value of your investment. Best of all, soundproofing can be managed on a budget. At Green Glue Company, our products are ideally suited for professionals and DIY'ers seeking to renovate their property.



GREEN GLUE NOISE-
PROOFING COMPOUND

a viscoelastic damping compound used between two sheets of drywall for wall and ceilings so significantly reduce the amount of sound transferring from one room to another.



GREEN GLUE JOIST TAPE

used between sub flooring and joists to eliminate squeaking floors and minimizing impact noise such as footsteps.



GREEN GLUE NOISE-
PROOFING SEALANT

seal gaps between walls and ceilings and floors as well as spaces around electrical boxes, light fixtures or other potential sound leaks.

Green Glue Noiseproofing Compound Step-by-Step Guide



Step 1

Tap your GG tube on a hard surface to bring compound away from the tip and prevent dripping. Cut a 5 mm hole in the tip of the tube with a utility knife. Screw nozzle tightly over the tip of the tube and cut a 5 mm hole in the tip of the nozzle. Place the tube in a standard 750 gr caulk gun to prepare for installation.



Step 2

With the first layer of drywall already installed, as per local building codes, apply Green Glue Noiseproofing Compound to the back of the second layer drywall by pulling the trigger to dispense the product from the tube. Leave a 5 to 8 cm border around the panel to allow for handling. The application pattern does not matter so long as you've distributed product evenly across the drywall. For best performance it is recommended that you use two tubes of compound on each 120x240 cm drywall panel.



Step 3

Once the first tube is empty, discard the cartridge and replace with the prepared second tube and dispense onto the panel. Finishing or mudding the first layer of drywall is not necessary if you stagger the second layer of drywall to cover any seams (recommended method).

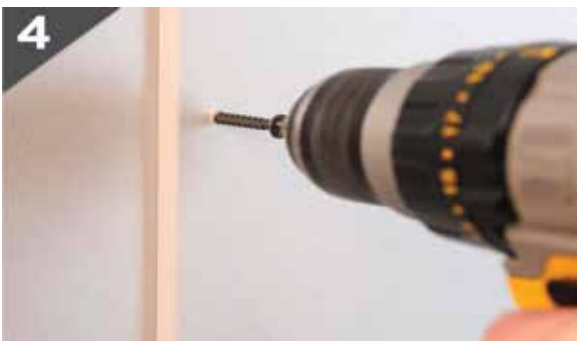

Step 4

Within 15 minutes of applying Green Glue to drywall, fasten the panel to the first layer of drywall, following local building codes. Leave a 5 mm gap along the top and bottom of the wall to allow for sealing. Continue with this process until you have applied Green Glue to all desired drywall panels.

Grimani Systems: Spellbinding home entertainment

With a combined 50+ years of experience building upwards of 600 recording and playback environments, Grimani Systems has created turnkey audio systems that immerse large private screening rooms with high-precision, dynamic, nuanced sound and deliver a transcendent and memorable experience.

From the most subtle Stradivarius violin to the biggest battle scene, Grimani Systems delivers crisp and immersive sound power. Our elegant technology solutions are designed specifically for luxury home cinemas, and truly convey the artistic vision of the musicians and filmmakers of the new ultra high-definition era.

ARCHITECTURE. Our components embody the highest level of design and mounting flexibility to blend seamlessly with the room's interior design and architecture.

POWER. Our systems deliver virtually unlimited acoustic power into large-room cinemas—effortlessly rendering music and film passages at virtually any volume level.

MUSICALITY. Our patented Conic Section Array™ waveguide, the loudspeaker's heart and soul, produces an unparalleled level of acoustical performance.

RELIABILITY. Smart efficiency through select components and the most direct digital signal routing of any large-room home cinema audio system ensures a superlative user experience and unmatched reliability.



ARCHITECTURALLY
INTEGRATED

All the Grimani Systems speakers are made as compact and shallow as possible in order to be concealed behind stretched fabric décor or acoustically transparent screen. The electronics are also efficiently conceived to use as little space as possible.



UNLIMITED POWER

The amplifiers and driver units all meet very high efficiency and high power specifications. Even at very high sound pressure levels, the system has ample reserve and headroom.



TIRELESSLY RELIABLE

With time-tested componentry, meticulous construction processes, and significant headroom, our devices will work reliably day-in and day-out. We can even monitor that all systems operate properly through cloud-based testing.



MUSICAL

Our systems are conceived as totally musical by audiophile engineers and designers with a long history in music performance and production.

RIXOS L
2-WAY BI-AMPLIFIED DSP

- Dual 8" woofers
- 1" dome in CSA™ waveguide
- 95dB efficiency
- 80Hz to 20kHz
- 600W rack amplifier
- DSP x-over and room EQ



RIXOS M
2-WAY BI-AMPLIFIED DSP

- Dual 6.5" woofers
- 1" dome in CSA™ waveguide
- 95dB efficiency
- 80Hz to 20kHz
- 300W rack amplifier
- DSP x-over and room EQ



RIXOS S & W
2-WAY BI-AMPLIFIED DSP

- 6.5" woofers
- 1" dome in CSA™ waveguide
- 91dB efficiency
- 80Hz to 20kHz
- 160W rack amplifier
- DSP x-over and room EQ



RIXOS C
CENTER BAR

- Dual 6.5" woofers
- 1" dome in CSA™ waveguide
- 95dB efficiency
- 80Hz to 20kHz
- 600W rack amplifier
- 2.5-way DSP x-over and room EQ



SIGMA
ACTIVE AMPLIFIED
DSP SUBWOOFER

- High performance
- High sound pressure level; 115dB in-room target
- Active amplified with integrated Digital Signal Processing EQ
- 18" driver
- 2000W integrated



HOME CINEMA MODULES: Just sit back...



Perfect sound and sharp images deserve first class seating

With a home cinema, you naturally want the clear sound and razor-sharp image. But of course you want to experience your film, series or documentary in full comfort. Home Cinema Modules have the chair for you, five models that you can customize to your taste and wishes.

Their chairs are designed in The Netherlands and produced in Europe. Every chair is custom made and of a guaranteed quality. So you can just sit back and enjoy whatever you are going to watch.

Our story

We are based in the Dutch town Enkhuizen, an hour north of Amsterdam, where the wind always blows, and people work hard. "The local attitude of giving your best effort, having fun doing it and always keeping your word, is in our DNA". Oh, and in the flatlands where we are, there is no escape from being down-to-earth. No-nonsense is our middle name.

Creating an immersive experience







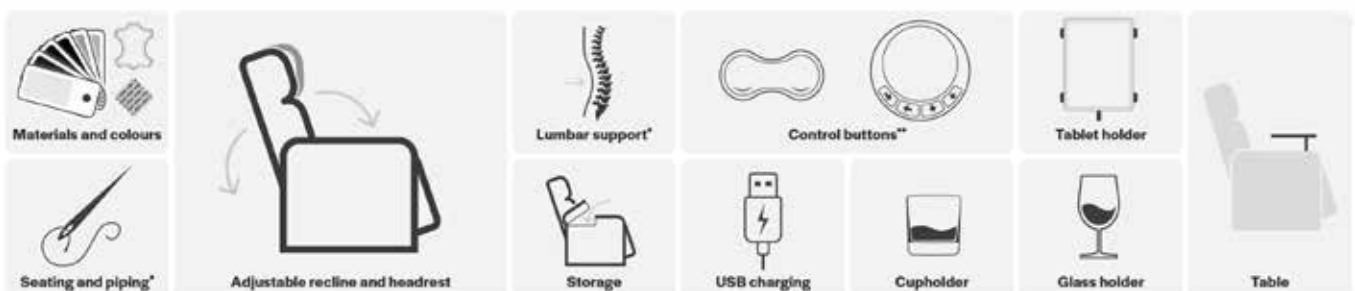





We call ourselves passionate nerds. We are genuinely in love with movies, the perfect cinema seat and creating the most glorious home cinema for our clients. If you are up for it, we can discuss the perfect stitching of a cinema chair. For hours. We can also talk about watching Formula 1 on a big screen, the best audio systems and the ultimate seating arrangement in your cinema. We are motivated to give you an immersive experience, within the comfort of your own home, from our passion and experience.

- Home Cinema Module from HCM Brochure 2021

Customazation options

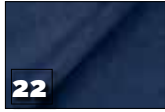
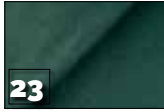

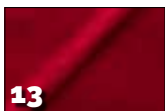
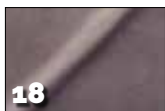
Fabric upholstery

Feel me Selection					
Hug me Selection					
Salvador Selection					

Leather upholstery

Fiesta Selection				
				
KEEN Selection				

Table of available options by model

Options	 HCM Atlas	 HCM Sirius	 HCM Regulus	 HCM Polaris	 HCM Vega
Your choice of material and colour Adjustable recline and headrest USB charging for your devices A glass and/or tablet holder Table in armrest (removable) Choice of control buttons Cupholder with integrated controls Cupholder (plain - stainless steel) Storage in armrest	✓	✓	✓	✓	✓
Optional lumbar support	✓	✗	✓	✗	✗
Diamond stitching	✗	✓ Headrest and seating	Standard	✓ Headrest and armrest	✓ Headrest and armrest
Row layout <small>When you choose more than one chair, join them in a row or place them separately.</small>					

JVC: Go further, be the first



3rd Generation Native 4K D-ILA Device

D-ILA device is the heart of projectors that plays an important role in projecting beautiful images. Device improvement continues to date – the third generation 0.69-inch native 4K D-ILA device improved the alignment control of liquid crystals and enhanced the flatness of image pixels to offer 1.5-times* the native contrast ratio compared to the Gen2 device. Additionally, improvements in the device manufacturing process have resulted in improved screen uniformity and enhanced image quality

Exceptional Brightness and Longevity with BLU-Escent Laser

Another essential aspect of projectors lies in their light source. The DLA-NZ series adopts JVC's original laser light source "BLU-Escent Laser" to achieve exceptional peak brightness of 3,300 lumens on the DLA-NZ900 and 2,700 lumens on the DLA-NZ800, both with longevity of 20,000 hours. When compared to the first-generation laser projector*, the projectors' brightness per effective wattage has improved 1.9-fold, which, as a result, also contributes to saving power through improved power efficiency.

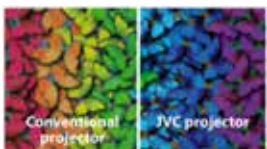

helps the projector achieve a wide color gamut beyond DCI-P3 as well as BT.709 for exceptionally rich colors

CINEMA FILTER



GEN2 8K/E-SHIFTX

C's proprietary 8K/e-shiftX, which is a combination of "e-shift technology" and "0.69-inch native 4K D-ILA devices" has made significant progress as the second generation 8K/e-shiftX



This D-ILA models support a variety of inputs including full 48Gbps 8K60p.

8K60P INPUT



GEN2 FRAME ADAPT HDR FUNCTION

The Frame Adapt HDR function has evolved into the second generation

JVC DLA-RS1100 D-ILA projector



Wrapped in a whole new design, which is packed with the latest projection features. For instance with the new 0.69-inch native 4K D-ILA device, the projector can produce high-definition native 4K resolution (4096 x 2160) images from its all-glass 65 mm diameter lens system.

HDR10 content can be projected at optimum quality with Auto Tone Mapping function, which automatically adjusts settings based on the mastering information. Combining brightness of 1,800 lm with dynamic contrast ratio of 400,000:1, the projector reproduces life like images for latest contents like HDR10 and Hybrid Log Gamma.

Original motion control technology Clear Motion Drive is renewed, and together with Motion Enhance which optimizes the driving of D-ILA device according to the motion of the image, motion blur is reduced significantly compared to conventional projectors.

JVC DLA-RS2100 D-ILA Laser projector



The DLA-RS2100E D-ILA projector is the world first home theater projector to feature 8K/60p/4K120p input. It is equipped with a new 8K/e-shift proprietary technology to reproduce 8K-quality images. The projector is driven by three native 4K D-ILA devices, high-quality 65 mm glass lens, and Ultra-High Brightness of 2,200 lumens. The BLU-Escent laser diode light source also contributes to project images that come close to reality. Compatible with the latest HDR10+, the projector boasts industry leading HDR performance. 8K, Laser, and HDR are the keywords that describe JVCs DLA-RS2100

JVC DLA-NZ800 D-ILA Laser projector



- Gen3 0.69-inch Native 4K D-ILA Devices (x3)
- 100,000:1 native contrast
- BLU-Escent Laser 2,700-lumen
- Gen2 "8K/e-shiftX"
- Gen2 Frame Adapt HDR with Deeper Blacks
- New Picture mode "Vivid"

JVC DLA-NZ900 D-ILA Laser projector



- Gen3 0.69-inch Native 4K D-ILA Devices (x3)
- 150,000:1 native contrast
- BLU-Escent Laser 3,300-lumen
- Gen2 "8K/e-shiftX"
- Gen2 Frame Adapt HDR with Deeper Blacks
- New Picture mode "Vivid"

Luxul: Reliable network, reliable system

Luxul is the leading innovator of simple-to-deploy professional grade IP networking solutions for use by custom installation professionals. Designed for use in both residential and commercial environments, the Luxul family offers a complete line of solutions that simplify network design and deployment—resulting in a scalable network that is both powerful and easy to install. With Luxul, installers can deliver the ultimate IP network without the complexity associated with traditional networking gear. All Luxul products include free lifetime support and a three-year limited warranty. Plus, Luxul equipment is available only through authorized distributors of residential and commercial integration products.

With Luxul You Get:

- **Simple Installation and Setup**
- **Products Not Sold Online!**
- **Free Lifetime Support**
- **3 Year Limited Warranty**

When you install a Luxul certified network we guarantee the performance of the network-including wifi coverage. If the network doesn't perform or provide full coverage, we will make it right at no additional cost to you.



Based on Your project plans, Luxul engineers will provide a custom network design.

THE RIGHT DESIGN



The certified design will provide you with a list of both required and optional equipment.

THE RIGHT EQUIPMENT



Complete the network design with domotz for remote monitoring and management.

THE RIGHT MANAGEMENT





AC3100 DUAL-BAND ACCESS POINT

The XAP-1610 is built with leading edge 802.11ac Wave 2 technology which offers support for more connected devices and increased data rates, delivering outstanding WiFi performance. It is compatible with all Luxul WiFi controllers, both standalone and embedded, and can be used standalone or as part of a multi- AP deployment. Installation is simple, requiring only a single Ethernet cable that delivers both power and data through the integrated PoE+ port.



EPIC 3 – DUAL BAND WIRELESS ROUTER

Featuring advanced 4x4 MU-MIMO (Wave 2) technology, the EPIC 3 with Domotz represents the latest in Wi-Fi technology and remote management for a superior Wi-Fi experience. Roaming is solved with its built-in wireless controller by our exclusive Roam Assist™ technology—allowing you to easily add up to two more wireless APs for a seamless Wi-Fi experience.



AGS-1008M 8-PORT GIGABIT SWITCH

Powered via PoE (or standard AC), the AGS-1008M 8-Port Gigabit Ethernet switch is a great choice for expanding your wired network in those hard to reach locations. With a magnetic mounting system as well as keyholes and optional rubber foot pads on the bottom of the switch, it offers the flexibility of being mounted to virtually any surface. The AGS-1008M lets you network up to eight Ethernet-enabled devices with full bi-directional Gigabit performance and is also compatible with Fast Ethernet devices.



AGS-1024 24-PORT GIGABIT SWITCH

The Luxul AV-Series 24-Port Gigabit Switch (AGS-1024) features rear panel ports and front facing LEDs (user selectable blue/green colors) for clean integration with AV rack systems. It provides exceptional performance, quality and reliability and is a great choice for expanding your wired network or setting up a VoIP, multimedia or extreme gaming environment. With a 48Gbps backplane, this 24-port switch lets you network up to twenty-four Ethernet-enabled devices at full-duplex, non-blocking Gigabit speeds.



madVR: Every pixel counts



OUR MISSION

Our mission is to create the ultimate cinema visual experience for you by providing the best video processing on the planet. No other company is dedicated to squeezing every single pixel to its extreme potential like we are. Every pixel counts. Don't settle for less..



madVR Envy MkII Series - Model Comparison

Features by model	Pro MkII	Extreme MkII
HDR Dynamic Tone Mapping (DTM)		
Frame by frame DTM, no metadata required	✓	✓
Advanced dual-algorithm scene change detection	✓	✓
Contrast Recovery (off, low, medium, high)	All	All
Shadow Detail Recovery (off, low, medium, high, very high, insane)	All except "insane"	All
Highlight Recovery up to 4K24 (off, low, medium, high, very high, insane)	All except "insane"	All
Highlight Recovery at 4K60 (off, low, medium, high, very high, insane)	-	All
DTM with 1080p60 HDR	★★★★★	★★★★★
DTM with 4K24 HDR	★★★★★	★★★★★
DTM with 4K60 HDR	★★★★	★★★★★
Scaling		
MotionAITM (per-pixel, AI-based motion interpolation)	-	✓
AI-based ring-free & artifact-free chroma upscaling	✓	✓
AI-based ring-free & artifact-free image upscaling	✓	✓
Upscaling can be switched to either optimize high or low quality sources	✓	✓
Upscaling to 4K24	★★★★★	★★★★★
Upscaling to 4K60	★★★★	★★★★★
Upscaling to 8K241	-	★★★★★
Upscaling to 8K601	-	★★★★★
Sharp & ring-free high quality downscaling	★★★★★	★★★★★

Aspect Ratios & Front Projection		
Automatic aspect ratio and black bar detection	✓	✓
Automatic IMAX aspect ratio changes	✓	✓
Masking for projection screens	✓	✓
Image shift for CIW projection	✓	✓
Advanced convergence correction	✓	✓
Automatic activation of JVC & Sony lens memories (via IP control)	✓	✓
Advanced geometry correction (e.g. for curved screens)	-	✓
AI-based anamorphic stretch upscaling for 1080p projectors	★★★★★	★★★★★
AI-based anamorphic stretch upscaling for 4K projectors	★★★★	★★★★★
AI-based anamorphic stretch upscaling for 8K projectors	-	★★★★★
Artifact Reduction and Edge/Texture Enhancement		
AI-based algorithm to reduce compression artifacts	★★★★	★★★★★
Algorithm to reduce banding artifacts	★★★★★	★★★★★
Edge enhancement (aka sharpening)	★★★★★	★★★★★
Texture detail enhancement	★★★★★	★★★★★
Planned Future Algorithms (added via software updates)		
AI-based motion interpolation	-	★★★★★
AI-based motion compensated video deinterlacing	-	★★★★★
AI-based motion compensated multi frame noise/grain reduction	-	★★★★★
AI-based grain agnostic sharpening	-	★★★★★
AI-based 4K HDR dynamic tone mapping processing	-	★★★★★
Additional undisclosed AI-based algorithms and features	-	★★★★★
General		
32 bit floating point per component processing	★★★★★	★★★★★
Extreme quality dithering algorithm	★★★★★	★★★★★
Smooth motion algorithm for displays with no (or poor) 24 FPS support	★★★★★	★★★★★
Automatic optimization of algorithm quality levels	✓	✓
3D LUT calibration using CalMAN, LightSpace, DisplayCAL, and more	✓	✓
Large 3D LUT w/ 274,625 (65 * 65 * 65) or 16,777,216 points (256 * 256 * 256)	✓	✓
Software updates easily installable via Envy menu	✓	✓
Remote technical assistance from authorized dealers ("madAssist")	✓	✓
Highly intuitive user interface, true plug-and-play installation in 1 minute	✓	✓
IP Control	✓	✓
Artifact Reduction and Edge/Texture Enhancement	Dual band IR + RF	Dual band IR + RF
AI-based algorithm to reduce compression artifacts	Pass-thru & TBD	Pass-thru & TBD
Algorithm to reduce banding artifacts	60 Hz: 4096x2160 in 12 bit 4:2:0, 4:2:2 or 8 bit 4:4:4, RGB	
Edge enhancement (aka sharpening)	30 Hz: 4096x2160 in 12 bit 4:2:0, 4:2:2 or 12 bit 4:4:4, RGB	
Texture detail enhancement	All up to 4K60	All up to 8K60
Hardware and Miscellaneous		
Warranty on parts and labor	24 months	36 months
General CPU processing power (cores / threads)	6/12	6/12
General graphics processing power (GFLOPS)	9.500	43.000
Specialized AI graphics processing power (Tensor core GFLOPS)	37,500	172.000 - 344.000
Quality when running multiple demanding algorithms simultaneously	★★★	★★★★★
HDMI 2.0b HDCP 2.2 18.0 Gbps input ports	1	1
HDMI 2.0b 18.0 Gbps input ports	1	1
HDMI 2.1 HDCP 2.3 48.0 Gbps output ports	1	1
HDMI 2.0b HDCP 2.2 18.0 Gbps zero-latency pass-thru	1	1
Paid options for future hardware updates	-	✓
Power consumption	60W - 205W	60W - 400W
Dimensions & Weight		
Unit dimensions with feet	440 x 443 x 192 mm	440 x 443 x 192 mm
Shipping weight	11.8kg	12.7kg
Rack units	4RU	4RU

Mag Audio Theatron: Experience real cinema at home

PRESENTATION

The MAG Theatron PERFORMANCE Series represents the next level of professional home theatre technology. Now you can enjoy the technology that is already thrilling audiences in thousands of theatres around the world.

Experience incredible dynamics combined with a unique beam pattern. You are enveloped, hear the finest details and almost limitless space.

All components and chassis are produced exclusively in the MAG Audio factory. MAG Audio has been a leading global supplier of professional sound systems for events and cinemas for over 25 years. Winner of many prestigious awards, member of the ICTA- International Cinema Technology Association and most recently exclusive audio supplier to the Cannes Film Festival.

UNIQUE FEATURES OF THEATRON PERFORMANCE LOUDSPEAKERS

- + Demodulationsringe zur Reduzierung von Verzerrungen
- + Three-way ventilation to increase dynamics and reduce compression
- + Two-layer sandwich copper-coated voice coils
- + Diaphragms with additional glass fibre for more stability and lower weight
- + 100% optimised transducer for the loudspeaker cabinet
- + Optimised delay behaviour between high and low frequency drivers
- + Asymmetrical left, right and centre horns for optimised coverage
- + Titanium high frequency driver with tangential surround



ABOUT THE SPEAKERS AND SUBWOOFERS

The high-performance speaker system is based on the same technology as MAG Audio's professional cinema speakers and uses very powerful woofers/midrange drivers together with extremely high-level tweeters.

From stadium concerts to large-scale cinemas, MAG subwoofers deliver the highest performance in terms of dynamic range and power handling.

Designed specifically for low-frequency effects, PERFORMANCE subwoofers use fibreglass-reinforced cone materials and a ribbed design with high-temperature sandwich voice coils.

This maintains rigidity and reliability while keeping weight low, resulting in superior sensitivity, dynamic range and power handling.

MAIN SPEAKERS			
			
M8-LCR	M12-LCR	M15-LCR	
SURROUND & ATMOS SPEAKERS			
			
SURROUND S4	SURROUND S6	SURROUND S8	ATMOS CS44
SUBWOOFERS			
			
HAMMER-12/15	DBA-12/18	SB-18/21	THOR-H

Magnetar: High-End Audio and Video 4K Ultra HD Blu-ray & Universal Players

ABOUT MAGNETAR

Magnetar's Brand concept: Restoring reality Committed to highlighting the extreme quality and innovative design of audio and video products, truly restores the color to the world we live in. Stemming from its product range: UDP Blu-ray Series, Magnetar adopts only the finest for the customers.

Magnetar Audio designs and manufactures 4K Ultra HD Blu-ray and SACD players.

BE A SELF EXPLORING ULTRA-WALKER

Magnetar's Brand concept: Restoring reality Committed to highlighting the extreme quality and innovative design of audio and video products, truly restores the color to the world we live in. Stemming from its product range: UDP Blu-ray Series, Magnetar adopts only the finest for the customers.

Whats more, "Self-Exploring" is the common goal Magnetar shares with all consumers. Quoted from Verhaeren "Life is a struggle with exploring the flame of his toil" Ultra-walkers require both passion and composure, romantic imagination balanced with rational practice. By the power of the exploration, bringing their fantasy to life.

Magnetar is such a ultra-walker, in the forefront on the industry with more than 20 years of professional R&D and OEM experience in High End Audio and Video products, and determined to push the limit in the quality and technology, keeping pace with new technological developments and firmly believing in its concept of restoring reality.

Magnetar provides sufficient energy for the spiritual pursuers of the new era.



Magnetar UDP800 4K Ultra HD Blu-ray Player

Equipped with the famous professional quad-core system Mediatek MT8581 chipset, the UDP800 4K UHD Blu-ray player features advanced image decoding and processing technology, with 4K ultra HD and HDR support, including Dolby Vision and HDR10+, providing clear and sharp picture and rich colors. With its metal body while being elegant and durable, the 4K UHD Blu-ray player UDP800 exudes the beauty of science and technology in simplicity and introversion, and makes your audio-video life even better.



Magnetar UDP900 Flagship Reference 4K Ultra HD Blu-ray Player

The latest designed 6-layer gold immersion main PCB circuit adopts high-precision, ultra-low noise 27MHz TCXO temperature compensated crystal oscillator doubling the high precision LDO power supply processing used on the UDP800 for ultimate accuracy. In addition, more digital signal processing and x10 LDO voltage stabilizers have been added compared to the UDP800. Murata multilayer ceramic capacitor TDK magnetic devices and 30 NCC electrolytic capacitors further improves audio and video quality. The UDP900 can play DVD, Blu-ray, and 4K UHD discs and even media files, featuring both H265 & H264 support. Picture quality is sharp and clear, with crisp details pleasing to the eyes.





Middle Atlantic: What great systems are built on



Middle Atlantic Products is part of the AV Division of Legrand, North & Central America, and has manufactured exceptional support and protection products to mount integrated AV systems in Residential, Commercial, Broadcast, and Security applications since 1979.

All of our products are designed and engineered in the US to maximize system reliability and to meet the needs of installers; from thermal considerations and built-in cable management, to pre-installed washers on our rack screws, we build in ways to save time and simplify the job. At the heart of every installation, you'll find Middle Atlantic Products - what great systems are built on.

Our Commitments

At Middle Atlantic, we practice truly sustainable manufacturing with the goal to minimize waste in all parts of our business. We don't do it because we have to. We don't do it because it's trendy. We do it because it is the right thing to do.

Our Quality Policy

To achieve excellence in both our products and our service, we will:

- Pursue internal and external customer satisfaction and meet applicable requirements
- Set objectives and continually improve and evolve our processes
- Reduce waste

Our Environmental Policy

To help protect the environment we will:

- Take action to protect the environment
- Assure MAP and our supply chain meet compliance obligations
- Set objectives and continually improve our processes
- Support Eco Design throughout product life cycle

Our Health and Safety Policy

To achieve a workplace free of injury and illness, we will:

- Develop and train qualified staff committed to accident prevention
- Set objectives and continually improve our safety practices and support wellness efforts at work and home
- Adhere to all safety rules regulations



ERK SERIES RACK - ERK-2125-CONFIG

Dimensions :
(D x H) 63,5 x 103,8 cm

An economical standalone rack with solid sides, the ERK series can also be ganged to create partitioned multi-bay installations for thermal management control, future growth or other purposes. Seismic certified to protect your components.

- Fully welded construction for strength
- Enclosure sides include top and bottom venting
- Convenient lacing points and slotted rail brackets for cable management
- Standard front and rear 10-32 threaded rackrail with numbered spaces
- Includes standard configurable rear door
- Includes LACE-OP lacer strip and 4 offset lacer bars
- Includes 15A, 10 outlet corded power strip
- Includes 3 vented shelves and one heavy-duty 4 point shelf
- Includes 3 2-space vent panels
- Includes fine floor caster base



ERK SERIES RACK - ERK-2725-CONFIG

Dimensions :
(D x H) 63,5 x 130,5 cm

An economical standalone rack with solid sides, the ERK series can also be ganged to create partitioned multi-bay installations for thermal management control, future growth or other purposes. Seismic certified to protect your components.

- Fully welded construction for strength
- Enclosure sides include top and bottom venting
- Convenient lacing points and slotted rail brackets for cable management
- Standard front and rear 10-32 threaded rackrail with numbered spaces
- Includes standard configurable rear door
- Includes LACE-OP lacer strip and 4 offset lacer bars
- Includes 15A, 10 outlet corded power strip
- Includes 3 vented shelves and one heavy-duty 4 point shelf
- Includes 3 2-space vent panels
- Includes fine floor caster base



ERK SERIES RACK - ERK-4025-CONFIG

Dimensions :
(D x H) 63,5 x 188,3 cm

An economical standalone rack with solid sides, the ERK series can also be ganged to create partitioned multi-bay installations for thermal management control, future growth or other purposes. Seismic certified to protect your components.

- Fully welded construction for strength
- Enclosure sides include top and bottom venting
- Convenient lacing points and slotted rail brackets for cable management
- Standard front and rear 10-32 threaded rackrail with numbered spaces
- Includes standard configurable rear door
- Includes LACE-OP lacer strip and 4 offset lacer bars
- Includes 15A, 10 outlet corded power strip
- Includes 3 vented shelves and one heavy-duty 4 point shelf
- Includes 3 2-space vent panels
- Includes fine floor caster base

Musical Fidelity: Power Amplifier



The perfect expansion

Power your main L/R channels, in its powerful bridged amplifier mode. Are you switching from 5.1 to 7.1? The M6x 250.4/2 gives you 2 channels of powerful bridged amp power for that too. Or use all 4 channels when upgrading your 7.1 system to a fully decked out 11.1 beast.

M6x 250.4/2 In Brief

- 250 watts per channel in stereo bridged mode
- 175 watts per channel in 4 channel mode
- Perfect expansion for your 5.1 or 7.1 AV receiver
- Perfect addition to our M6x 250.5, 250.7 or 250.11 home theater amps
- Excellent technical Musical Fidelity performance finally available for home theater enthusiasts
- Amazing load driving ability, unconditional stability will drive any loudspeaker
- RCA and balanced XLR inputs
- Trigger In/Out for seamless home theater integration
- Complete silent operation, no active cooling elements
- Excellent, massive and clean build quality

Bridged 2-Channel Stereo Mode

- Drive your main L/R channels in its powerful bridged stereo mode
- Already have a 5.1 power amp? The M6x 250.4/2 can be your new powerful stereo amplifier for your L/R main channels and expand your surround setup from 5.1 to 7.1
- Add 2 surround channels by upgrading your 5.1 system to 7.1
- Add 2 Dolby Atmos channels

4-Channel Mode

- Expand your 5.1 system to 9.1
- Expand your 7.1 system to 11.1
- Add surround channels and a passive subwoofer: turn your 2-channel HiFi Stereo System into a cinematic 5.1 experience by adding center and two surround channels, center and a passive subwoofer
- Add up to 4 Dolby Atmos channels



M6x 250.5 In Brief

- 250 watts per channel for each of its 5 channels
- Excellent technical Musical Fidelity performance finally available for home theater enthusiasts
- Amazing load driving ability, unconditional stability will drive any loudspeaker
- RCA and balanced XLR inputs
- Through Out for bi-amping
- Trigger In/Out for seamless home theater integration
- Complete silent operation, no active cooling elements
- Excellent, massive and clean build quality

**M6x 250.7 In Brief**

- 250 watts per channel for each of its 7 channels
- Excellent technical Musical Fidelity performance finally available for home theater enthusiasts
- Amazing load driving ability, unconditional stability will drive any loudspeaker
- RCA and balanced XLR inputs
- Through Out for bi-amping
- Trigger In/Out for seamless home theater integration
- Complete silent operation, no active cooling elements
- Excellent, massive and clean build quality

**M6x 250.11 In Brief**

- 250 watts per channel for each of its 11 channels
- Excellent technical Musical Fidelity performance finally available for home theater enthusiasts
- Amazing load driving ability, unconditional stability will drive any loudspeaker
- RCA and balanced XLR inputs
- Through Out for bi-amping
- Trigger In/Out for seamless home theater integration
- Complete silent operation, no active cooling elements
- Excellent, massive and clean build quality



Panamorph: We bring cinema home



Using the new anamorphic projector modes in today's most popular 4K home theater projectors from Sony, JVC, Digital Projection and Benq, anamorphic cinema provides up to 38% more brightness and 43% more pixels (Paladin DCR for 4K/4096/17:9 projectors) or 30% more brightness and 33% more pixels (Paladin for 4K/3840/16:9 projectors) compared to UHD letterbox projection for the brightest, most detailed movie experience in your theater – **even beyond that of non-anamorphic commercial cinemas** – while still providing multiple modes for watching TV content without moving the lens.

Paladin and Paladin DCR (Digital Cinema Resolution) lenses apply new vertical compression lens designs using patented, AR-coated, thin optical elements with integrated astigmatism correction for the highest clarity and transmission up through and including 8K projector resolutions while also allowing significantly greater light through the projector's primary lens compared to older horizontal expansion designs.



PALADIN DCR ON SONY 4K
PROJECTORS USING XM2 KIT



PALADIN DCR ON JVC 4K
PROJECTORS USING XM2 KIT



HOW DOES ANAMORPHIC ULTRAWIDE 4K CINEMA WORK?

Is your home theater all about getting the most immersive experience? The fact is that over 80% of the most popular movies are made in the UltraWide 2.4:1 aspect ratio for commercial theaters. These movies are meant and created to be the largest experience in your theater but on a flat panel TV or 16:9 projection system they are actually displayed as the smallest experience with the lowest performance.

So now today's most popular projector models also include anamorphic upconversion modes for use with an external anamorphic lens to convert their full performance into the larger 2.4:1 cinema movie format for the highest brightness and detail – all while still providing modes for watching 16:9 content. The anamorphic advantage means these projectors can actually deliver better movie performance than you can get in most commercial theaters.

HOW DOES ANAMORPHIC PROJECTION INCREASE THE BRIGHTNESS AND DETAIL OF MOVIES?

THE ORIGINAL MOVIE SURROUNDED BY UNUSED BLACK DISPLAY PIXELS.

Consumer UltraWide 4K movies are delivered using 3840 horizontal x 1600 vertical pixels to maintain their original 2.4:1 aspect ratio (ie $3840/1600=2.4$). When displayed in the center of the 4096 x 2160 pixels of a 4K/4096 projector there are 2,701,200 unused black display pixels surrounding the movie.



THE UP CONVERTED MOVIE USING THE REPURPOSED BLACK PIXELS.

Anamorphic 4K/4096 upconversion, now an included option in all new 2020 JVC and Sony 4K/4096 home theater projector models, applies digital scaling and possibly other image processing algorithms to convert the movie to a higher resolution of 4096 x 2133 so that previously unused display pixels are repurposed for a total increase of 43%. While no real, additional source resolution is implied, upconversion from real movie content has been proven to not only provide the additional image brightness from those millions of additional pixels but also additional realistic detail and subsequent improved clarity to the projected images. However, this process also leaves the movie appearing vertically stretched by 25%.



THE UP CONVERTED MOVIE ON A 2.4:1 SCREEN THROUGH A PALADIN DCR LENS.

The upconverted movie is optically compressed through an external Paladin DCR anamorphic lens to remove the 25% vertical stretch. This restores the original 2.4:1 movie aspect ratio while retaining the significant performance enhancement from the upconverted pixels for greater visual clarity combined with a net brightness increase of approximately 38% over projection of the original movie.



Prismasonic: Anamorphic Lenses

Cinomorph Anamorphic Lenses

A projector with a high quality anamorphic lens enables the use of an ultra wide screen with the side masking system. And this makes it possible to present the films exactly with the same intensive vibes as in the commercial cinemas. The setup is called Cinemascope. Also, it is appropriate to be aware that the big majority of all time movies has been filmed in this 2.40:1 aspect ratio, which refers to this word Cinemascope.

The true constant height system means that the widest movies are always also the biggest in size, and this is not happening in the home cinemas with a standard 16:9 aspect ratio. All the Cinomorph anamorphic lenses have the horizontal expansion optics, thus supporting perfectly a constant height, 2.40:1 Cinemascope setup. The lens series has different sister models based on both corrected prisms and cylindrical optics.

Why anamorphic ?

A native 16:9 projector produces gray bars on top and bottom of the picture, when the aspect ratio is wider than its native resolution. Thus, for movies in a 2.40:1 aspect ratio, as much as 33 % of the image's vertical resolution is lost since the pixels in those areas are displaying black. In 4K panel this means almost 2 millions wasted pixels.

In order to restore the resolution and the extra brightness it offers, the picture can be expanded vertically so that every pixel on a 16:9 panel becomes active. This picture processing can be done electrically with the AV equipment, but as a result the picture geometry now becomes distorted. Everything in the picture is now too tall and thin.

When the anamorphic lens is placed in front of the projector, it optically restores the original picture geometry by expanding the picture horizontally. It results not only a much bigger picture, but it now also feels like watching a film, not a video. Shouldn't you too be watching the movies in the original 2.40:1 Cinemascope format the way the directors recommend, just like in real commercial movie theaters.

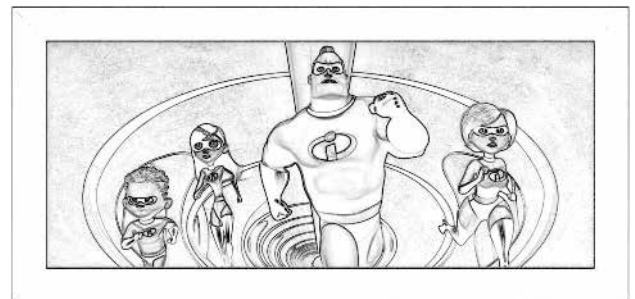
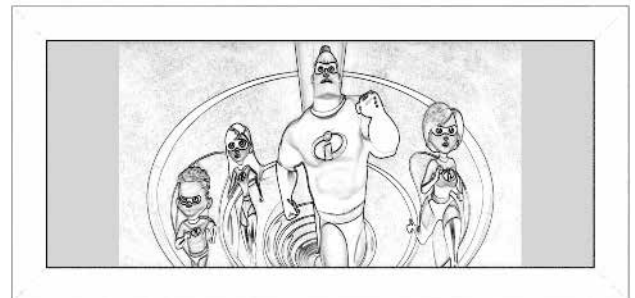
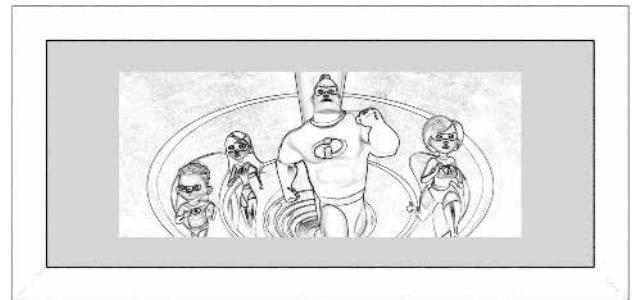

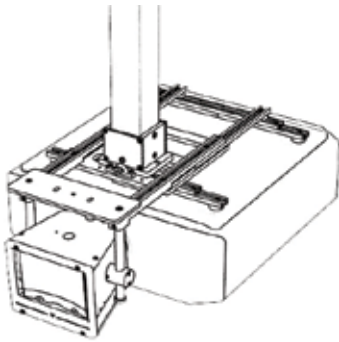

CEILING MOUNT

Ceiling mount for the Cinomorph lenses is an extremely sturdy, fully custom made construction, which allows to attach all the Prismasonic lens models with any projector in the market. Its design provides the system with a clean, compact and uncluttered look. The user defined, custom length extension rod can accommodate a drop from ceiling to inverted projector foot of between 22 - 106 cm (8.7 - 41.7 inches).



Cinomorph _prismatic

This lens is based on the movable achromatic prisms and the spherical focus corrector. The lens housing has two knobs on top to control the expansion ratio, which can be steplessly adjusted from pass thru mode up to 2.40:1 Cinemascope format. There is also a motor option available for assisting the aspect ratio switching.

Prism Optics

The optics is formed by two high precision, achromatic prisms and a spherical focus correction element. All the air-glass surfaces have broad band anti-reflection coatings to prevent the reflections, and to maximize the light output of the system. The achromatic optics means that the both prisms are made of two prism components of opposite polarity and different optical properties. The components are eventually seamlessly bonded together. The formed pair of achromatic doublets effectively reduces the chromatic aberration, which would occur as a color fringing in a picture projected through the single prisms.

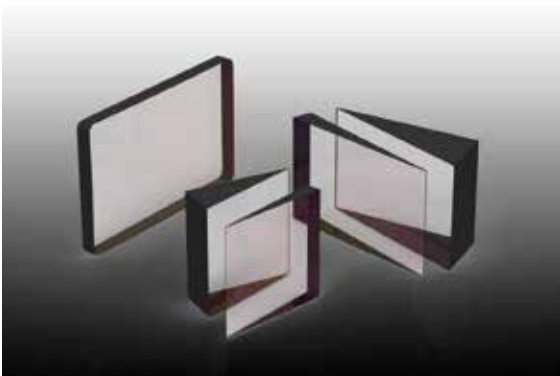

R_volution:

Your favorite movies, tv shows and concerts, all in one place

A Modern Media Center

The PlayerOne 8K includes R_video for free — the best entertainment hub available on the market, featuring an impressive user interface to explore your movies and TV shows. R_video scans your video files located on a local drive connected to your PlayerOne 8K, or on a NAS through the local network. Then R_video collects the cover art, background and various info such as casting, director, release date, rating, etc. Then you will just have to sit back in your home theater with your friends or family, choose your film or TV show easily. Browse a genre. Sort movies by rating, duration, or release date. Read a synopsis. Play the trailer. Then, press PLAY to enjoy your movie. After the end credit roll, wait for the auto launch of the next episode of your TV show. R_video is included with the purchase of the player. There is no need to purchase a subscription.

R_video features an automatic top banner (4K Ultra HD Blu-ray, Blu-ray, Blu-ray 3D, DVD, etc...), and a special top banner for Final Cut, Director's Cut, Theatrical Cut, Unrated, Disc 1/2, Bonus, Concert, Special Edition, etc. It also features: soundtracks while browsing movies or TV shows, parental control, exclusive R_video AI for the best movie identification possible, exclusive top quality multilingual movie covers, utilization of fanarts database, R_video DB and TMDB, filtering and sorting directly from the side of the user interface, automatic playback of the next TV show episode, search engine with display of movies from a specific actor or director and many more exclusive features.



R_VOLUTION PLAYERONE 8K



- Gold plated port
- Dobyly Vision and HDR10+
- 2.1 HDMI Output
- HDD Rack for 3.5" SATA (up to 32 To)*
- Bluetooth
- Wifi & Ethernet
- Android 11.0

The best possible picture technologies for an incredible home cinema experience

The R_volution PlayerOne 8K is a new media player compatible with Dolby Vision and HDR10+ powered by the powerful Amlogic Sg28X-K/J chipset !

The R_volution PlayerOne 8K is at the same time a high end media player and a media server capable of streaming content to other R_volution devices in a network through the exclusive R_share advanced streaming protocol.

The R_volution PlayerOne 8K comes with an internal hard drive bay capable of hosting up to 32 TB of movies,TV shows and concert files. It offers HDMI 2.1 output, compatibility with the latest AV1 codec up to 8K resolution in HDR and delivers stunning picture and sound quality to meet the needs of the most demanding home cinema enthusiasts.

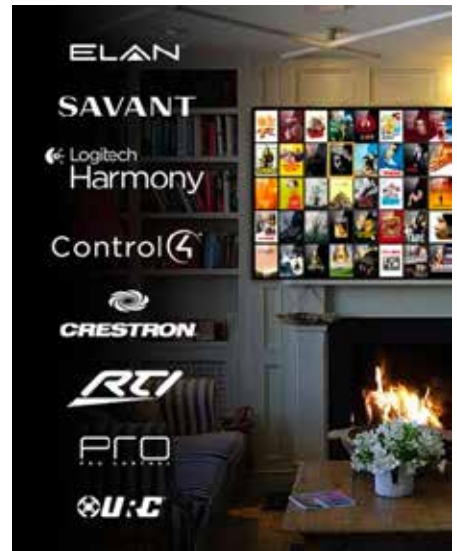

R_volution NAS

With high performance video processing technology and a rich media center application, the R_volution NAS RIP delivers an optimal value for R_volution users to build up an ideal audio / video library storage and feature rich entertainment hub. The R_volution NAS RIP was designed from the ground up to store movies and TV shows reliably on a modern array of hard disk drives without compression or loss of quality. Designed and assembled in France (Europe), the R_volution NAS RIP is highly scalable and able to continue operating even after a drive failure, without losing any content.

Our movie database named R_volution Db contains data for more than 1,200,000 movies titles including DVD, Blu-ray, Blu-ray 3D, 4K UHD, and 2,000,000 CD albums from around the world.

As your collection grows, you can add additional disks to increase storage capacity for your video and audio content. A single R_volution NAS provides storage capacity for up to 120,000 CDs, 12,000 DVDs, 2,000 Blu-ray or 1,000 4K UHD Discs. Several R_volution NAS servers can be grouped into a single system to store thousands of video and music content.

The R_volution NAS provides fail-safe storage for your collection using professional disk storage technology called RAID-5. If a drive fails, data is automatically restored to the hot spare disk, without loss of any content. The failed drive is replaced without turning off the server or disrupting playbacks in progress.

The R_volution NAS delivers movies, TV shows and music, over a standard residential network, simultaneously to R_volution players throughout the home. Once CDs, DVDs, Blu-rays, and UHDs are stored on R_volution NAS, they can be enjoyed immediately from any R_volution player.



HDD not included with the R_volution Players & NAS. We recommend HDD from Western Digital Blue or Seagate Exos or Barracuda for players And HDD from Western Digital RED or Seagate Ironwolf for NAS

RBH: Redefining the way you experience sound

THERE IS ONE SPEAKER FOR EVERY SITUATION.

RBH offers a wide range of speakers : freestanding, on-wall, in-wall and in-celling. Their subwoofers can also be placed in-wall, in-celling, and in-floor.

And if you only want a soundbar, there is the Ultra-3 that can be custom to match TV widths of 47 to 80" (perfect for the latest 48" OLED LG TV for exemple)

OUR MISSION

While there are many manufacturers of speakers, RBH Sound is unique in the fact we are one of the few remaining high performance loudspeaker companies still owned by the founder. While other companies have sold out to larger corporations, RBH Sound has chosen to stay privately held. This allows us to be flexible and react to the ever-changing needs of the audio market. It is our mission to "Redefine the Way You Experience Sound". To accomplish this, we engineer and design all of our products. Additionally, RBH Sound products are constantly tested and retested to ensure manufactured products are consistent with the design specifications. Building world class products is only half the battle; our marketing team has the tools and expertise to assist our channel partners in creating effective sales and marketing plans for their own markets.

DISCOVER OUR SERIES OF SPEAKERS



SIGNATURE SV SERIES

SIGNATURE IN-WALLS

VISAGE SERIES

ULTRA SERIES



SI-760R IN-WALL/LCR SPEAKER

Considered to be one of RBH's most versatile in-wall speakers, the SI-760R can be used horizontally or vertically for custom home theater systems or listening rooms. As the reference version of the SI-760, the SI-760R performs as main, center or surround speakers in a surround sound system. The SI-760R can also be teamed up with other Signature Reference Series models to create a custom timbre-matched home theater system.



SI-663R IN-WALL/LCR SPEAKER

The reference version of the SI-663, the SI-663R is designed for demanding custom installations where a center channel cannot be used or is intentionally removed for design considerations. When wired for dual channel operation, a pair of the SI-663R reference in-wall speakers can provide a discrete and dedicated center channel from the left and right speakers. When three SI-663/Rs can be used, the trio wired in single channel configuration, can provide a seamless, reference level front sound stage from their covert in-wall locations.



SI-615 IN-CEILING SPEAKER

When only the absolute finest performance will do, look to the Signature Series SI-615 in-ceiling speaker. Featuring a 6-1/2-inch aluminum cone woofer and a 3/4-inch pivoting ring-radiator tweeter, the SI-615 delivers award-winning performance that is on par with other Signature Series models. The SI-615 is primarily designed to be used as in-ceiling channels for object-based surround systems, but is also equally adept when used in a pair for high-end stereo listening or other whole-house audio applications. Accessories for this product may be found in the list below or check out the Accessories page for all of our speaker accessories.



SV-661WR ON-WALL SPEAKER

The SV-661WR is the higher-end brother to the already extremely capable SV-661W. Wall mounted performance is enhanced with upgrade to AMT tweeter and 6 1/2-inch reference aluminum cone woofers for increased power-handling and total accuracy. The SV-661WR easily makes the ultimate home theater possible without sacrificing valuable floor space. This speaker can be used as left and right main channels for music and home theater systems, or can also be used as center or surround channels. It can do it all. Seamlessly timbre matched to the entire reference SV family for easy integration as desired. Mount the SV-661WR throughout the home for music listening nirvana! Mounting is easy via a "French cleat" system.



SI-10 IN-WALL SUBWOOFER

Typically, freestanding enclosure or cabinet subwoofers perform well, but don't really complement an in-wall home theater installation. With the SI-10 in-wall subwoofer, we've taken the performance of our legendary TS-10 freestanding subwoofer and hidden it in the wall. The SI-10 features a non-powered 10-inch aluminum cone subwoofer inside a rigid MDF (medium density fiberboard) cabinet which fits in-between standard 2x4 wall studs. The only exposed part of the subwoofer is the black or white cloth grille.



Reavon: Universal 4K Ultra HD Blu-Ray Players

4K UHD DOLBY VISION SACD BLU-RAY PLAYER

This universal disc player has been elaborately engineered for the ideal disc playback. The UBR-X110 features extremely rigid construction to achieve high S/N ratio for quality audio and video performance. With support for the spectacular Ultra HD Blu-ray™ format, you can enjoy the beautiful experience with four times the resolution of 1080p Full HD. The UBR-X110 is compatible with the latest Dolby Vision® format that provides a stunning HDR imaging technology with extraordinary color, contrast, and brightness to the screen. Other features include SDR/HDR Preset Mode, SACD/DSD compatibility and dual HDMI output terminals.

PLAYING SACD DISCS

The Reavon UBR-X110 player is designed to extract information from CDs and SACDs as accurately as possible for optimal audio performance during playback.

UNIVERSAL PLAYER

As a universal disc player, the player can play various optical discs including the latest disc format Ultra HD Blu-ray which has four times the resolution of 1080p Full HD, as well as Blu-ray, Blu-ray 3D, DVD, CD and music, video and audio files such as FLAC, AIFF, DFF, DSF, JPG, TIFF, MKV and M2TS. The player can also play your audio and video contents from an external drive via USB or DLNA.

MEDIA INFORMATION ON-SCREEN DISPLAY

You can display the disc information on your screen by pressing and holding the remote control's INFO button. In addition to the playing disc's details, you can easily check mastering information such as MaxFALL (Maximum Frame Average Light Level) and MaxCLL (Maximum Content Light Level) available on some HDR content, as well as HDR and HDMI output information.

ULTRA-RIGID CONSTRUCTION

The 1.6mm thick chassis base is reinforced with a 3mm thick steel plate under the rigid base to minimize noise from mechanical movement of the optical assembly. The result is a significantly quieter, stiffer and stable chassis structure. This results in reduced vibration for increased performance and better overall operation of player components for more faithful listening.

100% DIGITAL

Dual HDMI output to separate audio and video and enjoy 4K HDR, while using an older generation non-4K compatible home theater soundbar or amplifier. High-efficiency CD-quality S/PDIF and coaxial digital audio output.

BACKLITE REMOTE CONTROL

The info button allows you to consult the detailed technical information of the program, such as audio and video output parameters. The Reavon UBR-X110 can be controlled by leading brands of universal remote controls such as RTI, Crestron, Control4 or Logitech Harmony.

Media Information	
Resolution	3840 x 2160
Frame Rate	23.976p
HDR Format	HDR10
Color Space	BT.2020 YCbCr4:2:0
Deep Color	10bit
Video Format	HEVC
Video Bitrate	48.5 Mbps
Audio Format	Dolby TrueHD Multi 48K
Audio Bitrate	5779.2 Kbps
Audio Channel	Multi

HDR Information	
Mastering Display	
Chromaticity (White)	x = 0.313,y = 0.329
Chromaticity (Red)	x = 0.680,y = 0.320
Chromaticity (Green)	x = 0.265,y = 0.690
Chromaticity (Blue)	x = 0.150,y = 0.060
Max. Light Level	1000nit
Min. Light Level	0.0050nit
Max. Content Light Level	0nit
Max. Frame-average Light Level	0nit
Electro-Optical Transfer Function	ST 2084

**Reavon UBR-X110
4K UHD Dolby Vision SACD Blu-ray Player**

This universal disc player has been elaborately engineered for the ideal disc playback. The UBR-X110 features extremely rigid construction to achieve high S/N ratio for quality audio and video performance. With support for the spectacular Ultra HD Blu-ray™ format, you can enjoy the beautiful experience with four times the resolution of 1080p Full HD. The UBR-X110 is compatible with the latest Dolby Vision® format that provides a stunning HDR imaging technology with extraordinary color, contrast, and brightness to the screen. Other features include SDR/HDR Preset Mode, SACD/DSD compatibility and dual HDMI output terminals.



Sanus: Affordable Racks and Furniture

RACKS AND FURNITURE

Whether you have just a few pieces of AV or network equipment to organize, or want to fully customize your set-up, SANUS server racks and media furniture provide the options and versatility to fit your needs.



Component Series AV Racks

Stable, secure storage to fit a complete AV system.

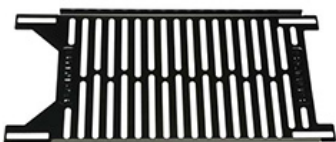

Component Series Rack Accessories

The Component Series AV racks accessories allow you to customize any Component Series rack to meet your exact needs.



EcoSystem AV Rack Accessories

With SANUS EcoSystem Accessories, your cables and cords stay organized providing a home for low-voltage equipment. Customize the EcoSystem rack to meet your specific needs and keep everything neat and tidy.



#1 Best-Selling TV Mount Brand

*In the U.S. NPD annual dollar sales period ending 12/21/20



U.S. - Based Customer Care

7-day a week expert customer care by phone, email, or chat



Warranty-backed Product

We stand behind our high quality products



Easy 1-2-3 Step Installation

Our products are designed for a DIY simple set-up



UL-Listed for Quality

Our rigorous testing ensures product quality and safety

Various options to meet your needs



MODEL CFR2115
15U AV Rack
Weight capacity : 225kg



MODEL CFR2127
27U AV Rack
Weight capacity : 340kg



MODEL CFR2136
36U AV Rack
Weight capacity : 350kg



MODEL CFR2144
44U AV Rack
Weight capacity : 450kg

Included rack accessories

	CFR2115	CFR2127	CFR2136	CFR2144
1U Shelves	1	2	2	2
2U Shelves	1	4	6	7
1U Blanking Panels	2	2	2	2
2U Blanking Panels	2	4	6	7
3U Blanking Panels	1	1	1	1
Tie Bars	1	2	3	4



Stackable Skeleton Racks and size option



15 U
CFR1615



20 U
CFR1620



30 U
CFR1615
+
CFR1615



35 U
CFR1620
+
CFR1615



40 U
CFR1620
+
CFR1620

Screen Innovations: Beautiful Lifestyle Innovations



TRANSFORMER

Transform Your Experience

Masking, Without Masking.

We weren't happy with the current offering in the screen masking arena so we ditched the mask completely and created a screen that, quite literally, grows to the perfect ratio, matching your content. It's like magic, and with Slate® you can now enjoy your perfect viewing experience in environments with ambient light.

The Perfect Ratio Every Time

Whether you're watching 16:9, 2.35:1, 2.40:1, or anything in-between - Transformer® fits. With our proprietary telescoping frame system, rest assured that your viewing experience will be the best one possible, every time.

1 Hour Installation







Gone are the overly complex, and time-consuming installations. With Transformer®, due to our simplified method of packing and pre-construction, you can unpackage your screen and complete the installation in 1 hour or less making our screen the most simple to install masking system in the world.

A Moving Experience

Getting the big screen experience is one thing. Getting the big screen experience with Transformer® is another thing all together. It's an experience that truly must be seen, heard, and felt to understand. That is why we created it - to give people something they have never experienced before.



Available materials

<p>BD Black Diamond</p>		<p>Max Width 1,800" (45720mm) Max Height 74" (1880mm) Gain 1.2 / 1.4 / .8</p>
<p>SL Slate</p>		<p>Max Width 3,600" (91440mm) Max Height 184" (4674mm) Gain 1.4 / 1.2 / .8</p>
<p>ST Short Throw</p>		<p>Max Width 113" (2870mm) Max Height 59" (1499mm) Gain .6</p>
<p>SW Solar White / Gray</p>		<p>Max Width 2,952" (74981mm) Max Height 184" (4674mm) Gain 1.3 / .85</p>
<p>PW Pure White / Gray</p>		<p>Max Width 3,600" (91440mm) Max Height 102" (2591mm) Gain 1.3 / .85</p>
<p>UT Unity</p>		<p>Max Width 3,600" (91440mm) Max Height 102" (2591mm) Gain 1.0</p>

Chose your favorite

Motorized :

- Zero-G
- Solo : Solo Pro 2 or Solo Pro
- Classic Motorized : 5 Series or 3 Series

Fixed :

- Zero Edge : Zero Edge Pro or Zero Edge
- Classic Fixed : 7 Series, 5 Series or 3 Series



SOLO



ZERO-G

Senor: The best solution for your home

The SENOR project began in 1995, with limited means but infinite ambitions for the future.

Now, after more than 25 years of hard work and strong commitment, we are proud that we have contributed our bit in the improvement of people's quality of life. As we have contributed along these years to the eradication of one of the main causes of unease and discomfort that we currently have to put up with: noise and vibration pollution.

Avoid the domino effect by installing SENOR insulators

After years of study and research, we are able to launch various vibration elimination tools for both construction and industrial sector. A revolutionary system that allows the constructive solution to be installed, both on ceilings, walls, floors and machinery, to be fully fixed. Our devices prevent any construction system from detaching from its location due to any contingency, such as a bad calculation of the weight distribution, the failure of one of the fixing mechanisms or simply a fire, thus avoiding further damage. This range, totally new and patented, is called DS and ANTI ROLL SYSTEM, (It is the most advanced security device of the moment).

Quality

SENOR guarantees through its international certificate that we comply with quality standards, being an organization with an effective quality management system, identifying areas for improvement and taking measures to progress in them. Our goal is to provide the best service to our customers.

We desing

We present the new products of SENOR with plus I+D+i of future present, range CONSTRUCTION and INDUSTRY. When you sit in front the News products SENOR then an incredible thing happen: the world around you appears in silence and you find yourself into an absolute tranquility.

To create such an intense experience we have gone further than ever, we have improved even the smallest detail, we have brought the new products "SENOR" to a new dimension.

We produce

All products manufactured by SENOR are registered and certified by the Spanish Patent and Trademark Office. Furthermore, a strong spirit with feet firmly planted on the ground and looking to the future, we develop solid foundations that support SENOR's philosophy: SAFETY, OPERATION, PERFORMANCE e INNOVATION. This strong determination and the truly unique product we produce have helped SENOR to be an international benchmark. We offer something unique

We offer something unique

SENOR, since its birth has always been clear that its main goal is to offer the market an innovation in terms of anti-vibration systems and all our products are aimed at the sector to benefit from these developments, both technology and installation and both of them offer a unique service that differentiates us from other competitors. Therefore, every year we surprise the market with our development and security system and, in this way, we will continue to work in the same way in the future.

Various products to meet your needs

TS-80 - The ultimate mount for concrete slab floors



The SE-TS-80 A 280 includes a PATENTED restraint system (two protrusions in its base) which limits the movement making sure the grip to the floor. It is designed in the shape of trapezium with X shaped base improving the elasticity of the system and proving an excellent performance in the soundproofing field.

TAV-500 - CUTTING-EDGE PERFORMANCE AND DESIGN



The TAV-500/11 R is a special acoustic plug to decouple the metal frame wall system from the slab and original walls. Thanks to this, the self-supporting metallic structure used in acoustic partitions and cladding systems gets completely isolated. Therefore, this is an essential product for deactivating noise pollution by solid means.

Its ergonomic design channels and isolates the fixing elements (screws) from the rest of materials, thus avoiding sound leakage

3800-01 / TD1+TA - ANTI-VIBRATION LATERAL WALL MOUNT FOR ACOUSTIC INSULATIONS



3800/01 TD1 + TA allows you to isolate and separate acoustic walls more economically than the 3802/03 model. However, 3800/01 TD1 + TA model has a disadvantage compared to the 3802/03 model: the ideal axial compression cannot be tested and reviewed by our engineers, since this process is carried out on site by the installer. What it does offer is the possibility of combining two thicknesses of sheet metal in order to extend or reduce the size of the air chamber depending on the acoustic needs of the work.

9600 TBM2 - HYBRID ACOUSTIC MOUNT FOR DOUBLE STUD PARTITION SYSTEM



9600 TBM2 model is designed to be used in double stud partition systems in buildings with low frequencies (cinema, pubs, disco, industry rooms, etc.) Its main purpose is to isolate the vibrations of partition walls. This wall mount works as follows: Brackets work freely during rubber and spring deformation in both directions. In this way, the polymer works always in axial compression.

Sofabaton: Simplify your Entertainment-Life

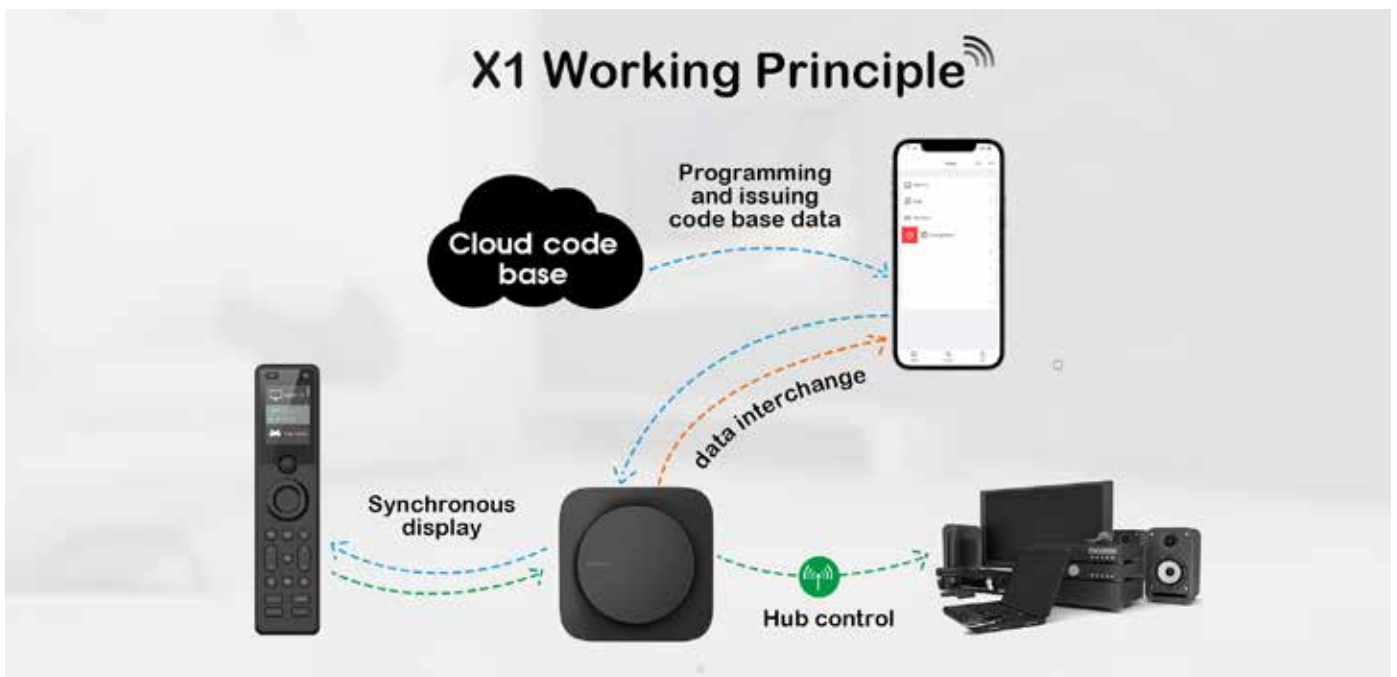
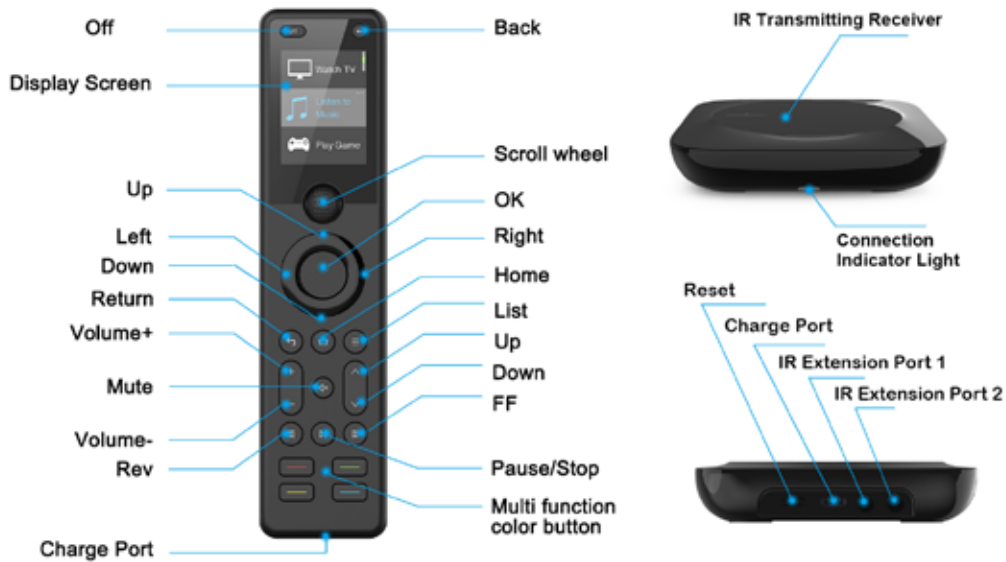

What is the Sofabaton X1 Series?

SofaBaton X1 remote is universally compatible with virtually all brands of audio and video equipment. Connects up to 40 devices in your home including TV, DVD, Blu-Ray, TV & cable boxes, gaming consoles, Apple TV, Roku and more. Seamlessly switch between devices via scroll wheel with 20inch display and enjoy convenient control with ease entertainment. This is an universal home theater remote for home cinema which is targeted at multi-devices scenario-based Activity control, while adding a wireless Hub,which we believe can better meet the needs of power users

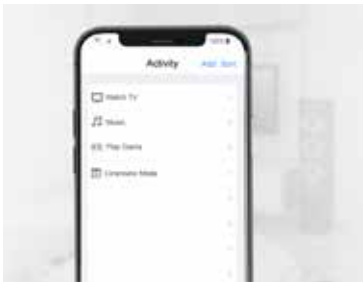

One Click Direct to Activity Mode

With SofaBaton Remote you can enjoy one click direct to the activity to trigger multiple devices, you can have fun creating as many as whatever you need. In Activities mode, Macros can be customized as flexible as you like.



No Bound By A Specific Point

SofaBaton centralizes command of all your devices by controlling them with IR, Wi-Fi or Bluetooth wireless signals within 10 meters 390 inches no need to worry about the device disconnected. You can hide away the cables and receivers and control everything from behind closed cabinets and doors, also you can point the remote anywhere.



Works with GA & Amazon Alexa

Works with alexa & google assistant to control your appliances, such as, "Google turn on your TV", "Google turn off TV".Or by just saying "Alexa,turn on TV", "Alexa,turn off TV"...



Compatible With Many Smart Home Devices

With the sudden development of technology By IFTTT/IOS shortcut Sofabaton Remote is accessible to your smart home system to your smart home systems which is easy to satisfy your new upgrade smart living+ mode.Make your home entertainment e life unprecedented minimalist. Say "GOODBYE" to the intricacies of remote control thoroughly.



Scroll Wheel Design

Smooth scroll wheel buttons with comfortable movement and pressing feel, which is very practical, allowing you to move up and down quickly and switch devices

Sonitus: World-Class acoustics.



From finest materials to finest products.

From the simple budget solution for a band garage to high class products for your studio, home cinema or even living room, depends where you wish to have a great sounding and looking space.

Products



LEVITERS

Sonitus Acoustics Leviter series are the first Sonitus Acoustics bright band absorber with a special velvet color coating (available in different colors). It is made of high performance Polyester acoustic foam and a velvet layer that is applied directly to the foam.



DIFFUSERS

Sonitus Acoustics diffusers are made of hard expanded polystyrene (EPS). Diffusers are used to make sound dispersion in your room, so that you get a similar sound energy in all parts of the room. Often used in home cinemas to get the same sound field for all listeners in the room at different positions. Sharpfusor and Fourfusor are 1D diffusers, also great for removing flutter echoes in spaces where absorption is not needed anymore. Installing the panels vertically and horizontally provides multi reflection. Low weight makes it easy to install on walls or ceilings.



BASS TRAPS

Bass Traps are acoustics absorbers for bringing low frequencies under control, eliminating standing waves and clarify sound image. Depending on room modes and sound quality in your space you can choose from 4 different Bass Trap models.

Versatile range,

- Cosmetic products that can be shown in your living room
- Professional products where you do not pay for the design and finish designed from the outset for professional studios or hidden behind an acoustic fabric in a home cinema room

Customized products

With the possibility of providing one of your family photo to transform an acoustic treatment to the design can adapt to a living room into an aesthetic setting representing family memories or pictures of landscapes, souvenirs,....

Very high quality products,

Tested, approved and imported by the leading acoustics specialists in the USA. Also used for many years by the world's leading manufacturers of loudspeakers and reference electronics in the world of hi-fi at the Munich trade fair (Europe's largest hi-fi trade fair).

Unbeatable price

- Product built in Croatia where raw materials and labour are much more affordable
- This results in a quality product sold 40% to 60% less than the competition.

Ecological mark

The manufacturer has invested considerably in packaging techniques that allow for to minimize transport packaging to its strict minimum.



BIGFUSOR MASSIVE SERIES



SVS: Sound R|Evolution

SVS Product Design Philosophy

SVS rumbled onto the audio scene to challenge the status quo of over-priced, underperforming "high-end" subwoofers and speakers and to bring convincing and immersive sound to more people than ever before. Why should thrilling home audio experiences be an elitist hobby limited to a small percentage of humanity? The SVS mission is to re-energize people's desire for awesome sound by bringing passion, fun and expertise back into to the mix. With this vision, SVS is leading a Sound R|Evolution.

From the stunning dynamics, revealing clarity and absolute transparency of our reference-grade loudspeakers, to the subterranean low frequency extension, effortless power, and unerring accuracy of our acclaimed subwoofers – award-winning SVS products guarantee a convincing, "like-being-there" experience with every listening session.



PRIME SERIES SPEAKERS

Truly immersive and high-end in every way, SVS Prime Series speakers borrow technology breakthroughs from the Ultra Series to set all performance benchmarks in their class making world-class audio more inclusive than ever before.



ULTRA EVOLUTION SPEAKERS

Breakthroughs in driver technology, acoustic engineering, and cabinet architecture fused with an obsessive pursuit of audio excellence. World-class sound is now possible for more people than ever.



1000 PRO SERIES SUBWOOFERS

Changed the subwoofer game by bringing world-class subwoofer performance to a new level of affordability. 1000 PRO Series subwoofers feature high-excursion 12-inch (SB-1000 PRO) and 10-inch (PB-1000 PRO) drivers and 325 watts RMS, 820+ watts peak power amplifier with advanced DSP tuning and smartphone app control.



2000 PRO SERIES SUBWOOFERS

Complete reimagining of the most popular SVS subwoofer models of all-time. 2000 Pro Series subwoofers feature 12-inch high-excursion driver and 550 watts RMS, 1,500+ watts peak power amplifier with advanced DSP tuning and smartphone app control.



3000 SERIES SUBWOOFERS

Reference subwoofer performance hits new lows. 3000 Series subwoofers feature 13-inch high-excursion driver with 800 watts RMS, 2,500+ watts peak power amplifier with fully discrete MOSFET output and SVS smartphone app for convenient DSP and control.



4000 SERIES SUBWOOFERS

Reference quality bass, groundbreaking SVS value. 4000 Series subwoofers feature 13.5-inch high-excursion driver, 1,200 watts RMS, 4,000+ watts peak power amplifier with fully discrete MOSFET output and SVS smartphone app for convenient DSP and control.



16-ULTRA SERIES SUBWOOFERS

The ultimate reference standard for bass. 16-Ultra Series subwoofer feature a 16-inch high-excursion driver with 8-inch voice coil, 1,500 watts RMS, 5,000+ watts peak power amplifier with fully discrete MOSFET output and SVS smartphone app for convenient DSP and control.



Address

256 Chaussée de Marche
5100 Jambes - Belgium

Opening hours

Tuesday to Saturday
10:00 - 18:00

Contact

benchmark-av.be
info@benchmark-av.be