

Case	<input type="checkbox"/> 'B', <input type="checkbox"/> 'H', <input type="checkbox"/> 'Y', <input type="checkbox"/> 'Z1', <input type="checkbox"/> 'Z2'
Display	<input type="checkbox"/> LCD, <input type="checkbox"/> LED, <input type="checkbox"/> LCD + backlight
Input	loop supply DC current
Measurement Range	4...20 mA
Operating Range	3...22 mA
Absolute Range	2...50 mA
Built-in Transmitter	<input type="checkbox"/> .....
Alarm Outputs	<input type="checkbox"/> 2 relays 5A/250VAC w/ NO contact, <input type="checkbox"/> 2 NPN 100mA/40V, non-isolated, <input type="checkbox"/> 2 PNP 100mA/40V, non-isolated
Alarm Differential (Hysteresis)	± 1 rightmost display digit
Keyboard Location ('Z1' and 'Z2' only)	<input type="checkbox"/> on front panel, <input type="checkbox"/> on rear panel
Loop Supply Voltage	4...36 VDC
Loop Voltage Drop	<input type="checkbox"/> < 3.5 V, <input type="checkbox"/> < 6.5 V
Measurement Error	< ± 0.05% from span ± 1 digit
Temperature Drift	< 0.025% from span for 1 °C
Warm-up Time	up to 1 min
Ambient Temperature / Humidity	-10...65 °C / <input type="checkbox"/> 0...85% RH, <input type="checkbox"/> 0...95% RH
Storage Temperature / Humidity	-20...65 °C / 0...95% RH
Protection Class: front / terminals	<input type="checkbox"/> IP68, <input type="checkbox"/> IP65, <input type="checkbox"/> IP54 / IP20

**LOOP-POWERED INDICATOR**

**BLP200**

OPERATION MANUAL



Please read this Operation Manual before mounting and operating.  
Save the Manual for future references.

**Warranty and Support**

..... serial number	<b>Warranty</b> BASI Instrument AB warrants this product to be free from defects in materials and workmanship for 2 years. If your unit is found to be defective within that time, we will promptly repair or replace it. This warranty does not cover accidental damage, wear or tear, or consequential or incidental loss. This warranty does not cover any defects caused by wrong transportation, storage, installation, or operating (see 'Specifications').
..... manufacturing date	
QC check mark .....(passed) (stamp)	<b>Technical support</b> In the unlikely event that you encounter a problem with your BASI device, please call your local dealer or contact directly our support team.
BASI Instrument AB p.o.box 53 SE-275 06 VOLLSJÖ, SWEDEN tel: +46 (0)40 88009 fax: +46 (0)40 929877 e-mail: sales@basi.se	
QD-8.2.4-WC	

Table 1

Parameter	Symbol	Description
<b>Configuration Parameters</b> (These parameters are part of Configuration level)		
Point Position	<b>Pnt</b>	Display decimal point position
Display Low	<b>L0</b>	Display value at low limit of the input range
Display High	<b>H1</b>	Display value at high limit of the input range
Display Offset	<b>OFFS</b>	Constant to be added to the measured input value
Filter Time	<b>Ft</b>	Relative time constant of the input filter
Filter Band	<b>Fb</b>	Zone around the measured value, within which the filter is active
Calibration	<b>CALE</b>	Enables / disables calibration mode
Alarm Set Point 1	<b>SP1</b>	Set-point value of alarm output 1
Direction 1	<b>dir1</b>	Control action direction of alarm output 1
Alarm Set Point 2	<b>SP2</b>	Set-point value of alarm output 2
Direction 2	<b>dir2</b>	Control action direction of alarm output 1
Return	<b>rtn</b>	Forced return to Basic level
<b>Keyboard locking Parameter</b> (This parameter is part of Hidden level)		
Lock Keyboard	<b>lock</b>	Keyboard locking mode
Return	<b>rtn</b>	Forced return to Basic level

Value	Unit	Notes
0 / 0.0 / 0.00 / 0.000	-	when indicating values with the input-signal measurement unit (ISU)
-1999 ... 9999	ISU	
-1999 ... 9999	ISU	
-1999 ... 9999	ISU	OFFSET
0 ... 255	-	higher value for better filtration
0 ... 3000	-	
<b>no. YES</b>	-	<u>For authorized personnel ONLY.</u>
-1999 ... 9999	ISU	
<b>---L---J---</b>	-	<b>---L_</b> (ON under set point), <b>---J---</b> (ON over set point)
-1999 ... 9999	ISU	
<b>---L---J---</b>	-	<b>---L_</b> (ON under set point), <b>---J---</b> (ON over set point)
-	-	
<b>dKEY, ESP, EKEY</b>	-	<b>dKEY</b> (keyboard disabled), <b>ESP</b> (only set-point adjustment enabled), <b>EKEY</b> (keyboard enabled)
-	-	

BLP200 is a loop-powered process indicator, equipped with a fully programmable 4-digit LCD or LED display, a 2-button keyboard, and 2 programmable alarm limits controlling 2 alarm outputs. BLP200-B and BLP200-H are designed for panel mounting, BLP200-Z1 and BLP200-Z2 – for mounting inside windowed sensor-protective heads as temperature displays with or without in-head transmitter, and BLP200-Y can be used as a stand-alone process transmitter with local display when a standard 4...20 mA in-head transmitter is also installed inside its protective box.

Electro-Magnetic Interference (EMI) Issues



Important note:

A built-in RC noise suppression circuit is connected in parallel with relay contacts. Full AC voltage isolation is NOT provided when relay contacts are open. Small AC current (≈ 1.5 mA at 230 VAC) still flows through the RC circuit.

- ◆ All signal wires must be shielded. They must not be packaged together with power cables.
- ◆ Never lay the signal wires close to inductive or capacitive noise sources, such as relays, contactors, motors, etc.
- ◆ All shields have to be grounded ONLY at one end, as closer as possible to the indicator terminals.
- ◆ Avoid sharing supply lines with powerful consumers, especially with inductive loads, switched on and off.
- ◆ To stop unwelcome interference signals entering through the power supply lines, use shielded 1:1 isolation transformer.
- ◆ Shunt all switched (not only those switched by the indicator) inductive consumers with special suppression networks: RC group and varistor - for AC loads, or diode - for DC loads.
- ◆ If the indicator operates in a very powerful EMI area, it has to be mounted inside a grounded metal shielding box.

Display Backlighting



- ◆ When installed (see 'Specifications'), the display backlight may be turned off.
- ◆ To disable the backlighting of a BLP200-B or BLP200-H, short out terminals A13 and A14.
- ◆ In case of a BLP200-Z1 or BLP200-Z2, short out the 2 bottom-right pins of the service connector (the ones accessible through the back panel).

Waste Disposal



Do not dispose of electronic devices together with household waste material.

If disposed of within European Union, this product should be treated and recycled in accordance with the laws of your jurisdiction implementing Directive 2012/19/EU on waste electrical and electronic equipment (WEEE).

Parameter Programming

Indicator parameters

BLP200 is a programmable device whose service behavior is determined by a set of parameters. All the parameters, along with their names, symbols, and value ranges, are given in Table 1.

Setting numerical parameter value

- ◆ Enter parameter value adjustment mode (see 'Program Levels').
- ◆ The whole part of the value together with the left zeroes appears on the display, and the rightmost digit blinks.
- ◆ To select another digit, press **SET**.
- ◆ The 3 rightmost digits can accept values from 0 to 9, and the leftmost digit can also accept the values - and +.
- ◆ To change the blinking digit value, use **UP**.
- ◆ Confirm the adjusted value by pressing simultaneously **SET + UP**.
- ◆ If the new value has not been confirmed and no key has been pressed for a certain period of time, value adjustment automatically ceases, and the parameter retains its initial value.

Setting symbolic parameter value

- ◆ Enter parameter value adjustment mode (see 'Program Levels').
- ◆ Read the blinking parameter value.
- ◆ To change the value, use **UP**, and to confirm, press **SET + UP**.
- ◆ If the new value has not been confirmed and no key has been pressed for a certain period of time, value adjustment automatically ceases, and the parameter retains its initial value.

☛ - Changing Point Position value reflects the real value of all parameters with ISU.  
E.g.: changing Point Position value from (0) to (0.0) would change a Set-point value of 100 to 10.0.

Wiring

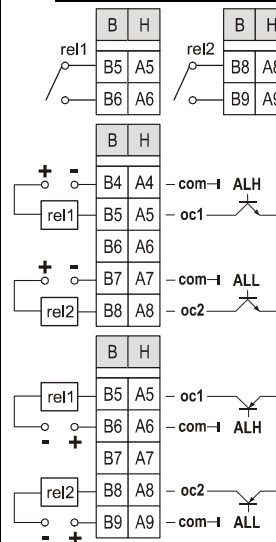

Wiring BLP200-B/H

- ◆ Wire the current loop through terminals B1(+) and B3(-) (for case 'B') or A1(+) and A3(-) (for case 'H').
- ◆ Connect the outputs with regard to their types (see 'Specifications') via the respective terminals.

Keyboard

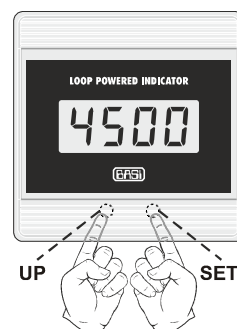

BLP200-B/H keyboard

There are 2 programming keys – **UP** (⬆) and **SET** (⬇) – on the device front panel.

BLP200-Z keyboard

The keys **UP** (⬆) and **SET** (⬇) are either on the front or the rear panel (see 'Specifications').

BLP200-Y keyboard

- ◆ The programming keys are hidden on the back of the electronic module.
- ◆ To reach the keys, open the box as described in 'Mounting'.
- ◆ After finishing off adjustments, close the box.

**Low-pass filter**

This first-order filter acts ONLY within a certain band around filter output value. This has been designed to cut periodic noises outside the communication signal spectrum.

- ◆ Filter operation is defined by two parameters:  
**Filter Time** (defines filter time constant) and **Filter Band** (defines filter active band around filter output value).
- ◆ If the newly measured value differs from the filter output by more than **Filter Band**, the filter resets with a new initial output value (newly measured value).

**Error Messaging**

- ◆  $\overline{\text{---}}$  (over range) - display value over **Display High** + 10 or sensor damaged.
- ◆  $\underline{\text{---}}$  (under range) - display value below **Display Low** - 10 or sensor damaged.

**Calibrating****Important notes:**

- ◆ 1-point calibration (only 4 mA or 20 mA) is enabled.
- ◆ After exiting calibration mode, the device automatically changes the value of the Calibration parameter to  $n\emptyset$ .

- ◆ Connect a milliampere simulator to the 'current loop' terminals and adjust simulated current to 4 mA or 20 mA.
- ◆ Set **Calibration** parameter to  $4\text{E}5$ .
- ◆ From Basic level, press and hold **SET** until  $rRL$  appears. Release the key.
- ◆ Select the 1<sup>st</sup> calibration point - ,  $4$  or ,  $20$  - and confirm with **SET + UP**.
- ◆ During calibration, the unit displays  $cccc$ .
- ◆ After finishing calibration of the 1<sup>st</sup> point, the device automatically starts the calibration procedure for the 2<sup>nd</sup> point. To interrupt, press **UP** to display  $rLn$  and return to Basic level with **SET**.
- ◆ To calibrate the 2<sup>nd</sup> point, repeat the above steps.

**Important notes:**

- ◆ Cases 'Z1' and 'Z2' are designed to be incorporated inside protective heads with distance between centers of the female threaded openings respectively 55 mm and 68 mm.
- ◆ Never over-tighten the screws because this may damage the indicator case!

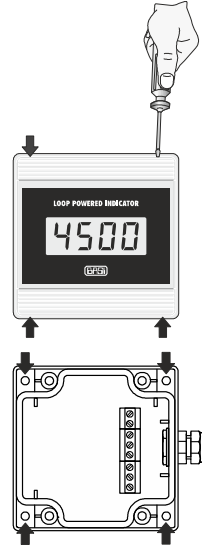
**Panel mounting ('B', 'H')**

- ◆ Place BLP200 into a 90x90 mm (for case 'B') or 90x42 mm (for 'H') panel cut-out.
- ◆ Tighten it into place using the enclosed mounting brackets.

**In-head mounting ('Z1', 'Z2')**

- ◆ Unscrew the protective head top cover.
- ◆ Dispose the wired indicator inside the head.
- ◆ Fix with the 2 attached screws.

**Wall mounting ('Y')**

- ◆ Insert the tip of a suitable screwdriver into one of the openings between the lower and the upper cap on the front panel. Use the screwdriver as a lever to open the caps.
- ◆ Unscrew the 4 screws and remove the part of the box containing the electronic module and the front panel.



For subsequent installations, skip this step because the mounting screws are already accessible through the 4 corner holes under the front panel caps.

- ◆ Fix the box to the wall with proper mounting screws through the 4 back holes on the terminal box.
- ◆ Put the electronic module and the front panel caps back.

**DIN-rail mounting ('Y')**

Your BLP200 can also be mounted on a 35 mm DIN rail by the means of special DIN rail clamps, which have to be ordered separately.

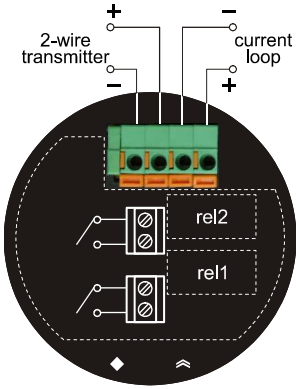

**Important note:**

See 'Specifications' for the current loop data and alarm outputs' load capabilities.

**Wiring BLP200-Z**

- ◆ Wire the indicator via its spring terminals as shown on the wiring diagram and on the unit back.
- ◆ When no transmitter is to be connected to the device, short out 'transmitter' terminals.
- ◆ Connect the outputs if such are installed (see 'Specifications') via the respective screw terminals on the external relay PCB.

**Wiring BLP200-Y**

- ◆ Open the box as described in 'Mounting' to access the 8 terminals on the main board.
- ◆ Wire the current loop through terminals 1(+) and 2(-) as shown on the left.
- ◆ In case of transmitter installed, wire as illustrated on the second diagram.
- ◆ To connect NPN or PNP outputs, follow respectively the third or the fourth wiring diagram.

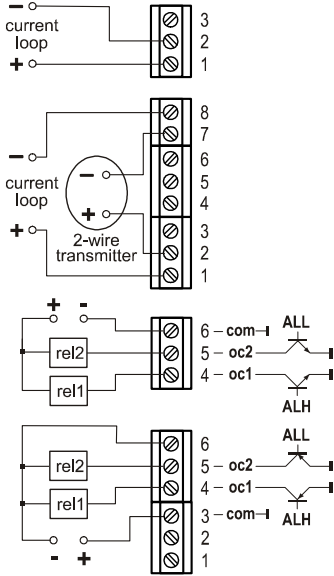

**Basic level**

At power-on, BLP200 enters Basic level. At this level, the device indicates the measured value (PV) with a resolution, according to the Point Position parameter.

**Configuration level**

This level contains the configuration parameters of the device.

- ◆ Enter from Basic level by pressing and holding **SET** until **CONF** appears.
- ◆ Scroll the parameters with **UP**.
- ◆ To enter parameter value adjustment mode, press **SET**.
- ◆ If no key has been pressed for a while, the device automatically returns to Basic level, storing all confirmed changes.
- ◆ For quick exiting and saving, use key combination **SET + UP**.
- ◆ For forced exit, select **REN** and press **SET**.

**Hidden level**

- ◆ Hold **SET** depressed while turning the power on and until **LOCK** appears.
- ◆ Set keyboard locking mode.

**Output Control**

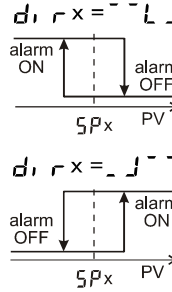

**Alarm output operation**

- ◆ The alarm outputs operate according to the alarm parameters.
- ◆ The outputs deactivate when an error has been detected (see 'Error messaging').



**Important note:**

At power-off, the relays retain their state.

**ON/OFF alarm algorithm**

The static characteristic of an alarm relay controlled by an ON/OFF algorithm is shown on the left drawing.