

Bipolar Signal Isolator v4 6 BSI134

Block Diagram

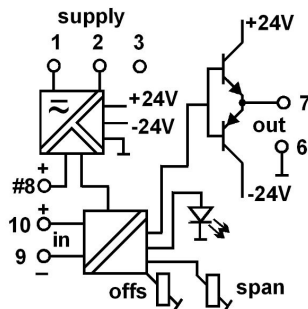

The BSI134 produces an isolated bipolar output signal from any type of input signal. Input signals can be bipolar or unipolar process signals such as -10 to +10V or 4 to 20mA. The output drive circuit is factory configured to provide load independent voltage or load independent bipolar current output. Maximum current drive for voltage output is 20mA at ±20V output. Applications requiring output >20mA up to 2A as is the case with hydraulic drive solenoids, can be accommodated using an external bipolar DC-power supply with a separate heat sink, carrying the drive transistors. Final calibration is trimmed using the front accessible OFFS and SPAN 15-turn trim adjustments. The output signal level is indicated by a green LED on



the front, giving a clear indication of module function. All units are fitted with a 0.5 second filter. This filter constant can be increased or decreased if required. RF and power transient protection are with all CE modules. Power supply isolation is achieved by the use of transformers for AC power and DC/DC converter for DC power.

General Specifications

Size: 52 W x 70 H x 110 D (mm).
 Mounting: DIN-Rail, gear plate.
 Termination: Screw terminals on front.
 Protection class: IP40.
 Weight: 0.330 kg.
 Dimensions standard unit: 52 x 70 x 110mm.
 Dimensions 100mA unit: 85 x 70 x 110mm.
 Housing material: ABS.
 Accuracy: 0.1% of span.
 Front 'OFFS' adjust: ±25% typical.
 Front 'SPAN' adjust: ±25% typical.
 Temperature effect: 0.02% per °C.
 Operating temperature: 0...+60°C.
 Output load effect: less than 0.25% up to max. load.
 Output loop drive: ±10mA into 0 - 2000Ω
 ±20mA into 0 - 1000Ω.
 Output voltage load: ±10V into 500Ω minimum
 ±20V into 1kΩ minimum
 Short circuit duration 10 minutes max.
 Input/output isolation: 2kV rms.
 Line Regulation: Less than 0.02% change for ±10% supply voltage change.
 Linearity: 0.05% of span.
 Repeatability: 0.05% of span.
 Storage temperature: -20 to +70°C.
 Response time: 0.5 sec for 0 - 90% of step input. Faster or slower response on request.
 Power requirements: 3W.
 Electromagnetic compatibility: Complies with CE and AS/NZS

6 BSI134-X XX X 0 XX

Power Supply:

- 1 = 90-280Vac 50/60Hz (65-280Vdc).
- *) 3 = 16-48Vac 50/60Hz (10-60Vdc)
- *) 6 = 8 - 60Vdc.
- *) 9 = Other (Specify).

Input:

Unipolar

- *)01 = 0 - 100mV (1MΩ) 11 = 0 - 100µA (1kΩ)
- *)02 = 0 - 200mV (1MΩ) 12 = 0 - 1mA (220Ω)
- *)03 = 0 - 500mV (1MΩ) 13 = 0 - 5mA (240Ω)
- 04 = 0 - 1V (1MΩ) 14 = 0 - 10mA (100Ω)
- 05 = 0 - 2V (1MΩ) 15 = 0 - 20mA (51Ω)
- 06 = 0 - 5V (1MΩ) 16 = 0 - 50mA (20Ω)
- 07 = 0 - 10V (1MΩ) 17 = 4 - 20mA (51Ω)
- 08 = 0 - 20V (1MΩ) 18 = 10 - 50mA (20Ω)
- 09 = 0 - 50V (1MΩ)
- 10 = 0 - 100V (1MΩ) *) 19 = Other specify

Bipolar

- *)20 = ±50mV (100kΩ) 25 = ±10V (1MΩ)
- *)21 = ±100mV (470kΩ) 26 = ±20V (1MΩ)
- *)22 = ±200mV (1MΩ) 27 = ±10mA (100Ω)
- 23 = ±1V (100kΩ) #*) 28 = 3 wire pot 1kΩ min
- 24 = ±5V (470kΩ) *) 29 = Other ± specify

Output:

- 1 = ±1V (50Ω min) 5 = ±1mA (20kΩ max).
- 2 = ±5V (250Ω min) 6 = ±5mA (4kΩ max).
- 3 = ±10V (500Ω min) 7 = ±10mA (2kΩ max).
- 4 = ±20V (1kΩ min) 8 = ±20mA (1kΩ max).
- *) 9 = Other specify.

Output Options:

- 00 = None.
- *) 01 = Output ramp.
- *) 02 = Output >20...500mA (External bipolar supply)
- *) 03 = Output 500mA-2A External bipolar supply.
- *) 04 = Dither for hydraulic applications.
- *) 05 = External ratio adjust, Specify range
- *) 06 = Zero output for loop loss (4 - 20mA input).
- *) 08 = Customised response time (Specify).
- *) 09 = Output 2A-5A External bipolar supply.
- *) 99 = Other (Specify).
- *) = Price Extra.
- # = 2.5V reference on pin 8 FOR potentiometer input only.

Connection

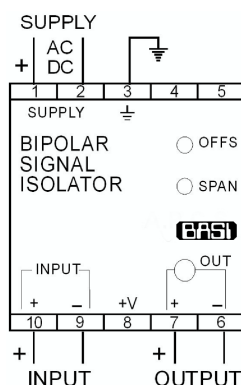

In the interest of development and improvement, BASI reserve the right to amend, without notice, details contained in this publication. BASI will accept no legal liability for any errors, omissions or amendments.