

AUDIOPHILE ACOUSTICS

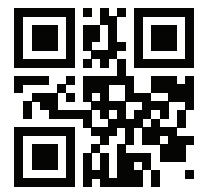

B2[®]

SWEET LIKE DANISH

Zero Five - The Falcon

Zero 8 - The Osprey

USER MANUAL

PRODUCT ID:

Z5FALCOND19

Z8OSPREYD19

WWW.B2AUDIO.COM / WWW.FACEBOOK.COM/B2AUDIO



INTRODUCTION

As one of the most iconic companies offering high output amplifiers, innovation has its price. They say imitation is as a kind of flattery, but it can easily become financially unwise going down the same route. B2 Audio is an innovator, and we set more trends instead of just following them. We have decided that it is time to start anew. Our team has reviewed each of our designs, noting what works, what doesn't, and what we could upgrade.

From each component used to the thickness of PCB, we left no rock unturned so to speak. The result is an entirely new amplifier line, designed in the USA with the help of the Danish DNA we offer in all of B2 audio's products. B2 Audio is proud to present the new Zero amplifiers:

Zero Five - The Falcon & Zero 8 - The Osprey

Zero Five - The Falcon & Zero 8 - The Osprey

Reviving the Zero's.

These amplifiers set multiple world records and have secured championships all over the world. This is a task with an immense responsibility. In their time the Zero line was the benchmark to compare with. Not only in terms of performance, but even appearance. We decided to merge the DNA and heritage of the Zero series amplifiers, but to build with the technology of the future. Our previous amplifiers have been noted as world's first and created a demand for how future amps should be equipped. The Zero 5 (The Falcon) and the Zero 8 (The Osprey) follow in the footsteps of our previous models. These amplifiers are not meant to be the most powerful on the market. They are a statement of quality both in design and in the components used. Sourced from all over the world and not accepting anything other than the best they boast amazing power ratings but offer reliability and a sense of pride in ownership rarely seen in this era. Unique features combined with proprietary designs will keep them ahead of the game, offering an advantage which will show the true value of the product.

To obtain the full potential of any amplifier & to minimize failure, it is advised to upgrade your stock electrical system. Don't take any shortcuts, a better electrical equals enhanced performance and stability.



AUDIOPHILE ACOUSTICS

IS THE CORNERSTONE OF B2 AUDIO. IT'S THE PHILOSOPHY OF ADDING SOMETHING UNIQUE. KEEP IN MIND THAT CONTINUOUS EXPOSURE TO SPL ABOVE 100 DB CAN SERIOUSLY DAMAGE YOUR HEARING. TODAY'S HIGH POWER AUTO SOUND SYSTEMS CAN EASILY PRODUCE SPL OVER 140 DB. ENJOY YOUR MUSIC WITH SENSE.

TABLE OF CONTENTS

DESIGN FEATURES	3	STRAPPED SPEAKER WIRING	9
PANEL LAYOUT	4	SLAVE 2 CONTROL PANEL & WIRING	10
POWER TERMINAL	5-6	ACCU8 CROSSOVER & BOOST	11
INSTALLATION & PREPARATION	7	TROUBLESHOOTING	12
SPEAKER CONNECTION	8	AUDIO PRECISION CHARTS	13
STRAPPED CONTROL PANEL SETTING	9	WARRANTY INFO	14

DESIGN FEATURES

	<i>Zero Five / The Falcon</i>	<i>Zero 8 / The Osprey</i>
CIRCUIT CONFIGURATION:	HI-EF CLASS D	HI-EF CLASS D
FREQUENCY RESPONSE:	10 HZ - 300 HZ	10 HZ - 300 HZ
SIGNAL TO NOISE RATIO:	> 95 DB	> 95 DB
INPUT SENSITIVITY:	5 V - 0.2 V	5 V - 0.2 V
CROSSOVER CIRCUIT:	18 DB / OCT	18 DB / OCT
LOW PASS CROSSOVER:	35 HZ - 250 HZ	35 HZ - 250 HZ
SUBSONIC CROSSOVER:	10 HZ - 50 HZ	10 HZ - 50 HZ
DAMPING FACTOR:	400	400
BASS BOOST (45 HZ):	0 - 9 DB	0 - 9 DB
PHASE:	0 - 180°	0 - 180°
REMOTE W/ CLIP INDICATOR:	INCLUDED	INCLUDED
POWER INPUT TERMINAL GAUGE:	0 GA X 3	0 GA X 4
FUSE RATING:	600 A	850 A
DIMENSIONS:	19.68" X 12.4" X 2.95"	23.62" X 12.4" X 2.95"
DIMENSIONS:	500 X 315 X 75 MM	600 X 315 X 75 MM

All features are subject to change in the continuing effort to improve the products without notice.

CONTINUOUS OUTPUT POWER (RMS)

		<i>The Falcon</i>		
	12 V < 1% THD	13.8 V < 1% THD	14.4 V < 1% THD	16 V < 1% THD
OUTPUT POWER @ 4 Ω:	1500 W	2000 W	2300 W	2500 W
OUTPUT POWER @ 2 Ω:	2500 W	3200 W	3600 W	3800 W
OUTPUT POWER @ 1 Ω:	3500 W	5000 W	5500 W	5800 W

CONTINUOUS OUTPUT POWER (RMS)

		<i>The Osprey</i>		
	12 V < 1% THD	13.8 V < 1% THD	14.4 V < 1% THD	16 V < 1% THD
OUTPUT POWER @ 4 Ω:	2200 W	3000 W	3400 W	3500 W
OUTPUT POWER @ 2 Ω:	3800 W	5500 W	5900 W	6000 W
OUTPUT POWER @ 1 Ω:	6000 W	8000 W	8500 W	9000 W

DESCRIPTION OF SPECIFICATIONS

Operation below minimum impedance will stress the amplifier & void the warranty.

Excessive heat will also appear at a faster rate and the amplifier will go into thermal protection.

Protection can also be caused by the following

- * Speaker overload
- * Short circuit
- * Input Voltage - RCA & Power Supply

The PCB is a HI-EF Class D design. THE HI-EF circuit optimizes efficiency & improves performance even at low voltages.

Operational voltage 9V ~16V. 18V models can be modified upon request, but with a limited warranty.

Operational voltage will also be affected by the load of the amplifier.

*In order to get the full power output of the amplifier, it is crucial that your electrical system is correctly (over)dimensioned.

PANEL LAYOUT

The Falcon / The Osprey

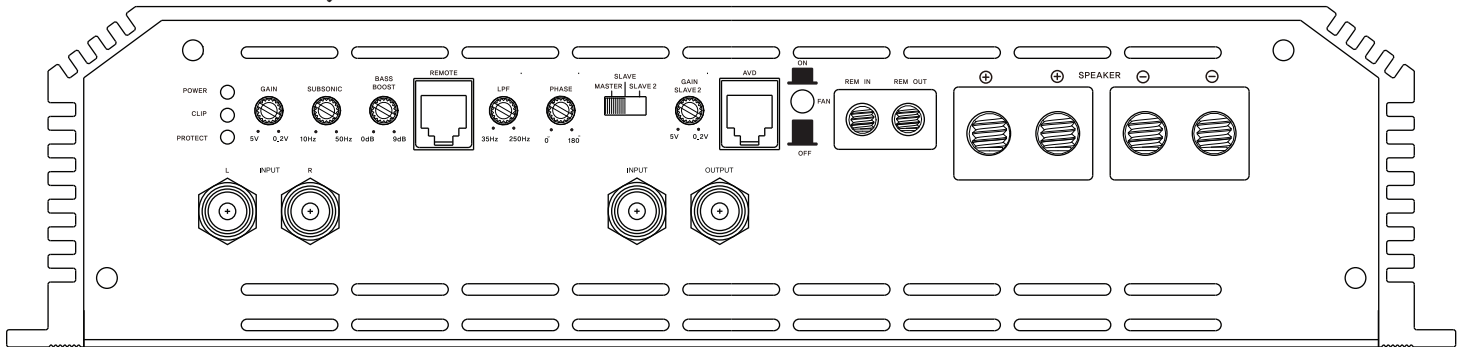

INPUT

RCA signal input for left & right channel.
A minimum of 0.2V input signal is required for correct operation. Using only 1 input will minimize input signal and amplifier will need to be gained as such.

POWER & PROTECTION INDICATOR

Power LED, blue light shows correct operation,
Protect LED, red light shows general malfunction, faulty connection or thermal protection.

CLIP INDICATOR

The LED will light up if signal is clipped. An occasional flashing light is acceptable, a constant lit diode is not.

GAIN (5V-0.2V)

Adjusts signal input voltage from the input source to match the amplifiers input stage.
0.2V ~ 5V is the operational voltage.
Voltages beyond may cause errors or damage to the input section.

SUBSONIC

Variable subsonic setting from 10 Hz to 50 Hz.
It is highly recommended to set it according to the tuning of your subwoofer enclosure to avoid unnecessary strain to your sound system.

BASS BOOST

Level control of 0~9 dB @ 45 Hz.

REMOTE LEVEL CONTROL PORT

Connection of external signal level control with clip indicator. Caution, it is not a volume knob and shall be adjusted in accordance with the amplifiers gain.

LPF (LOW PASS FILTER 20 HZ -200 HZ, 24 DB/OCT)

Adjusts the cut off point for the low pass crossover at the frequency chosen.

PHASE

Variable phase adjustment from 0 ~ 180°

MASTER / SLAVE / SLAVE 2

Master & slave settings enables strapping of the amplifier with another identical amplifier to achieve twice the power. When set in master, this unit will be sending the signal to the slave unit, that will have the switch set to input slave with the rca connected to the input. Slave 2 setting will work as a daisy chain of subsequent amplifiers. Here each amplifier will work independently, but the signal input will be taken from the master amplifier's output making gain matching easier.

GAIN SLAVE 2

In daisy chain mode or by gain matching, voltage could eventually differ a few tenths. The slave 2 gain provides fine tuning of the gain signal from the master amp's output.

AVD

Connection for external voltage display showing the true input voltage for the amplifier.

POWER TERMINALS

The Falcon

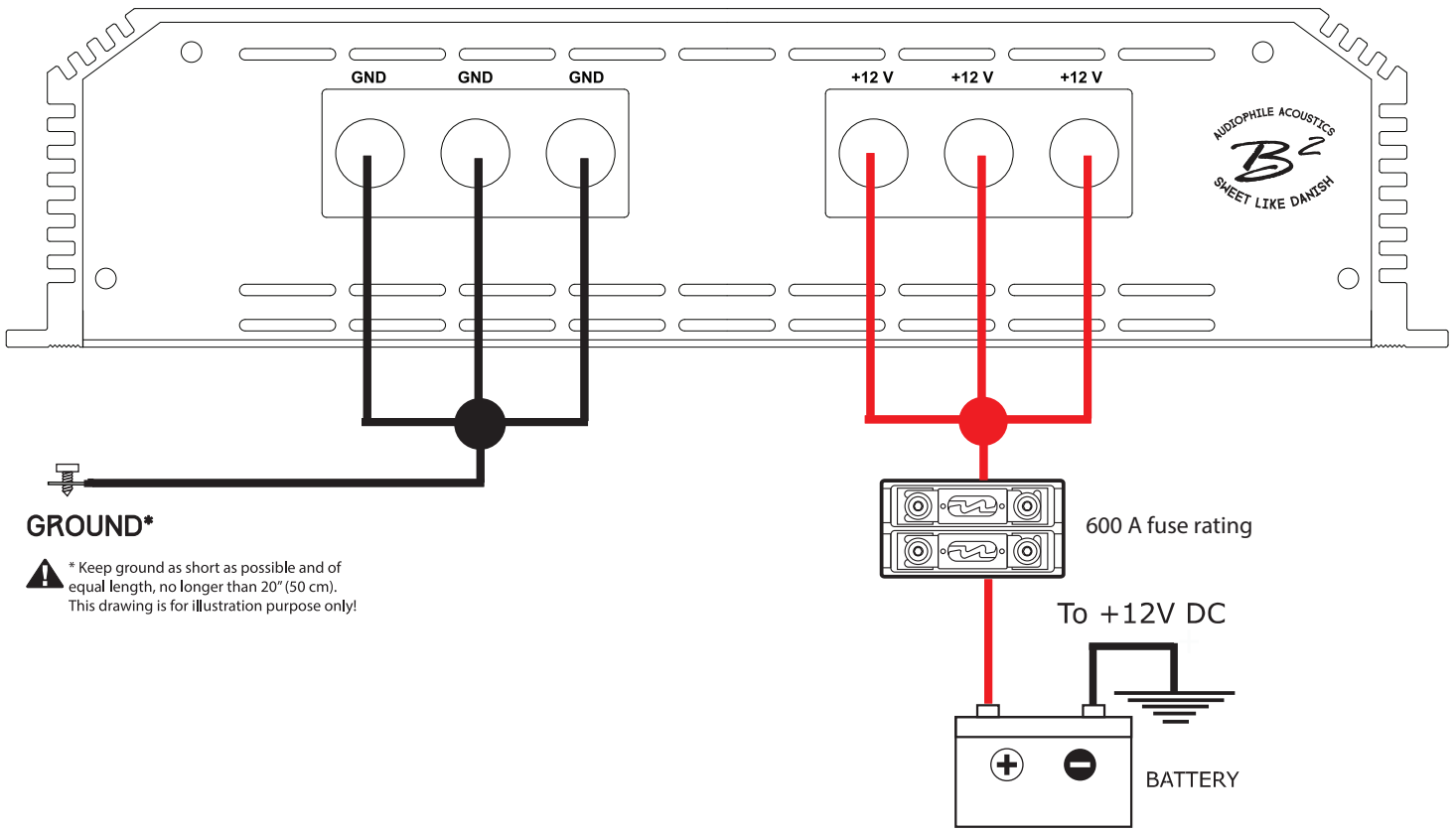

GROUND*

⚠ * Keep ground as short as possible and of equal length, no longer than 20" (50 cm). This drawing is for illustration purpose only!

POWER TERMINAL

GND (GROUND CONNECTION)

Connects to the vehicle's chassis. Keep as short as possible (< 20" / 50 cm). Use minimum 0AWG cable for optimal operation.

+12V (POWER CONNECTION)

Connects to the positive terminal of the battery. For specified performance 0AWG cable is required. Fuses shall be placed within 8" / 20 cm of the battery.

⚠ CAUTION

INSTALLATION OF THE AMPLIFIER SHALL BE DONE IN THE FOLLOWING STEPS:

1. Connect the +12V wire, keep in mind this wire has to be fused at the battery as well.
2. Ensure the ground is appropriate, then connect it to the amplifier.
3. Connect the switched remote.
4. Reattach negative wire (ground) to the battery.
5. Operation over 16V will cause the amplifier to go into protect & can void the warranty!

B² audio

POWER TERMINALS

The Osprey

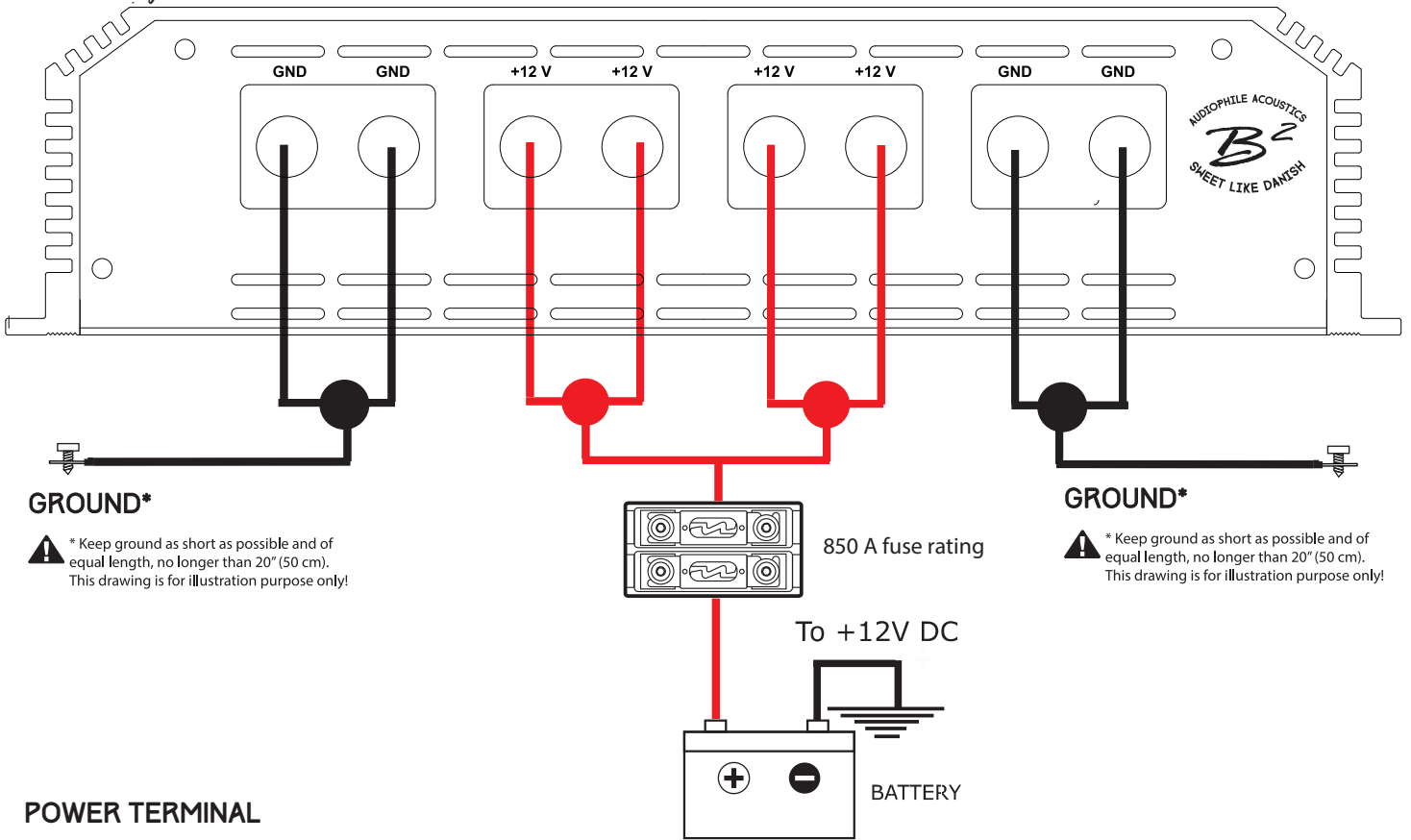

GROUND*

⚠ * Keep ground as short as possible and of equal length, no longer than 20" (50 cm). This drawing is for illustration purpose only!

GROUND*

⚠ * Keep ground as short as possible and of equal length, no longer than 20" (50 cm). This drawing is for illustration purpose only!

POWER TERMINAL

GND (GROUND CONNECTION)

Connects to the vehicle's chassis. Keep as short as possible (< 20" / 50 cm). Use minimum 0AWG cable for optimal operation.

+12V (POWER CONNECTION)

Connects to the positive terminal of the battery. For specified performance 0AWG cable is required. Fuses shall be placed within 8" / 20 cm of the battery.

⚠ CAUTION

INSTALLATION OF THE AMPLIFIER SHALL BE DONE IN THE FOLLOWING STEPS:

1. Connect the +12V wire, keep in mind this wire has to be fused at the battery as well.
2. Ensure the ground is appropriate, then connect it to the amplifier.
3. Connect the switched remote.
4. Reattach negative wire (ground) to the battery.
5. Operation over 16V will cause the amplifier to go into protect & can void the warranty!

B² audio

INSTALLATION

INSTALLATION CONSIDERATIONS

If you choose to install the amplifier by yourself, please read the entire owner's manual carefully. Before you start your installation, please take all steps into consideration. If in doubt, please go to www.b2audio.com for authorized distributors / dealers that will be able to configure your set up & ensure the warranty of your amplifier.

PREPARATION

Disconnect the negative (-) battery cable before mounting or making any connection. Check the battery & alternator ground (-) connection. Make sure they are properly connected/dimensioned & free of corrosion. Before selecting a mounting location for the amplifier, please take cooling & safety into consideration. Avoid areas with excessive vibration & up side down installation!

In order to avoid excessive heat from the amplifier, it is recommended to find a mounting location that allows for vertical positioning of the heatsink fins. For safety purposes, install the amplifier in a dry and well ventilated location and make sure no cables or other harness of the car is interfaced with the mounting location or will present a hazard to the car's cable, control cables, fuel lines/tanks, hydraulic lines or other components of the vehicle. Route the RCA cables away from high current wires, if possible run RCA, Power and Speaker cables individually and with a good distance from each other.

POWER CONNECTORS

12V (POWER CONNECTION)

Before mounting the amplifier, disconnect the negative (-) wire from the battery to protect any accidental damage to the amplifier or the audio system. The amplifier is equipped with quad 0 AWG power & ground terminals. It is crucial that all terminals are used with the adequate cable to ensure correct operation. Connect the power cables to the power terminal labeled as +12V.

The amplifier is not equipped with fuses, so external fuses are required at both the battery and the amplifier. Connect one end of the fuse holder to the power cable and the other end of the fuse holder to the positive battery terminal within 8" / 20 cm of the same cable. The same shall be done at the other end of the cable that connects to the amplifier. The fuses will protect the system and the vehicle against the possibility of a short circuit in the power cable. Make sure that the fuses and the fuse holder is according to the system requirements.

GND (GROUND CONNECTION)

Locate a secure grounding connection as close as possible to the amplifier. Make sure the location is clean and provides a direct electrical connection to the chassis of the vehicle. Connect one end of an equal sized cable as the positive cable to the location of ground. It is important that the ground cable is as short as possible, but no longer than 20" / 50 cm at maximum. Run one end of the cable to the grounding point. Run the other end of the cable to the mounting location. Connect the ground cable to the terminals labeled as GND.

REM (REMOTE CONNECTION)

Run a remote turn on cable from the switched +12 V source. This may be a toggle switch, a relay, the source unit's remote output cable or power antenna trigger cable. Connect the remote turn on cable to the power terminal labeled as REM. The REM out terminal is mainly intended for connection of another amplifier ran in a chain, but it can also be used for other units.

INPUT (RCA CABLE)

Run the RCA cables away from the high current cables / speaker cables and connect to the amplifier. Use high quality cables with a secure grounding point to avoid amplifier malfunction and / or alternator whine.

B² audio

SPEAKER CONNECTION

The Falcon / The Osprey

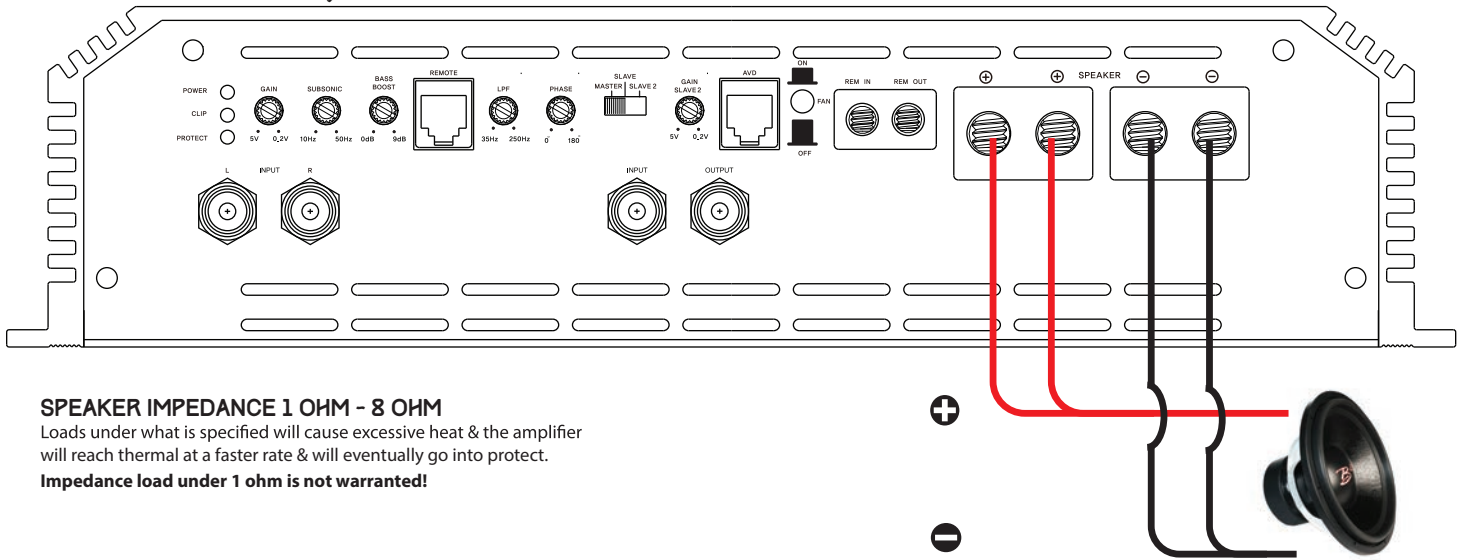

SPEAKER IMPEDANCE 1 OHM - 8 OHM

Loads under what is specified will cause excessive heat & the amplifier will reach thermal at a faster rate & will eventually go into protect.

Impedance load under 1 ohm is not warranted!

We recommend using minimum 10 Ga speaker cables to acquire the intended performance & efficiency. Run the speaker cables from your speakers to the amplifier's mounting location. Ensure these are ran separately and away from high current cables and if possible the RCA cables as well. In all cases where cables are penetrating the vehicle's chassis use grommets to protect the cable.

Connect the speaker wires according to the terminals on the speaker(s). Strip 3/8" / 1 cm of insulation of the end of each cable and twist the cable strands together tightly. Make sure there are no stray strands that could touch other cables or terminals as it can cause a short circuit.

Crimp spade plugs over the end of the cable or tin the ends with solder to provide a solid terminal.

Connect the cable ends to the amplifier as shown in the diagram. Note, the amplifier's speaker terminals are internally bridged.

⚠ CAUTION

INSTALLATION OF THE AMPLIFIER SHALL BE DONE IN THE FOLLOWING STEPS:

1. Connect the +12V wire, keep in mind this wire has to be fused at the battery as well.
2. Ensure the ground is appropriate, then connect it to the amplifier.
3. Connect the switched remote.
4. Reattach negative wire (ground) to the battery.
5. Operation over 16V will cause the amplifier to go into protect & can void the warranty!

B² audio

STRAPPED CONTROL PANEL SETTING / SPEAKER WIRING

The Falcon / The Osprey

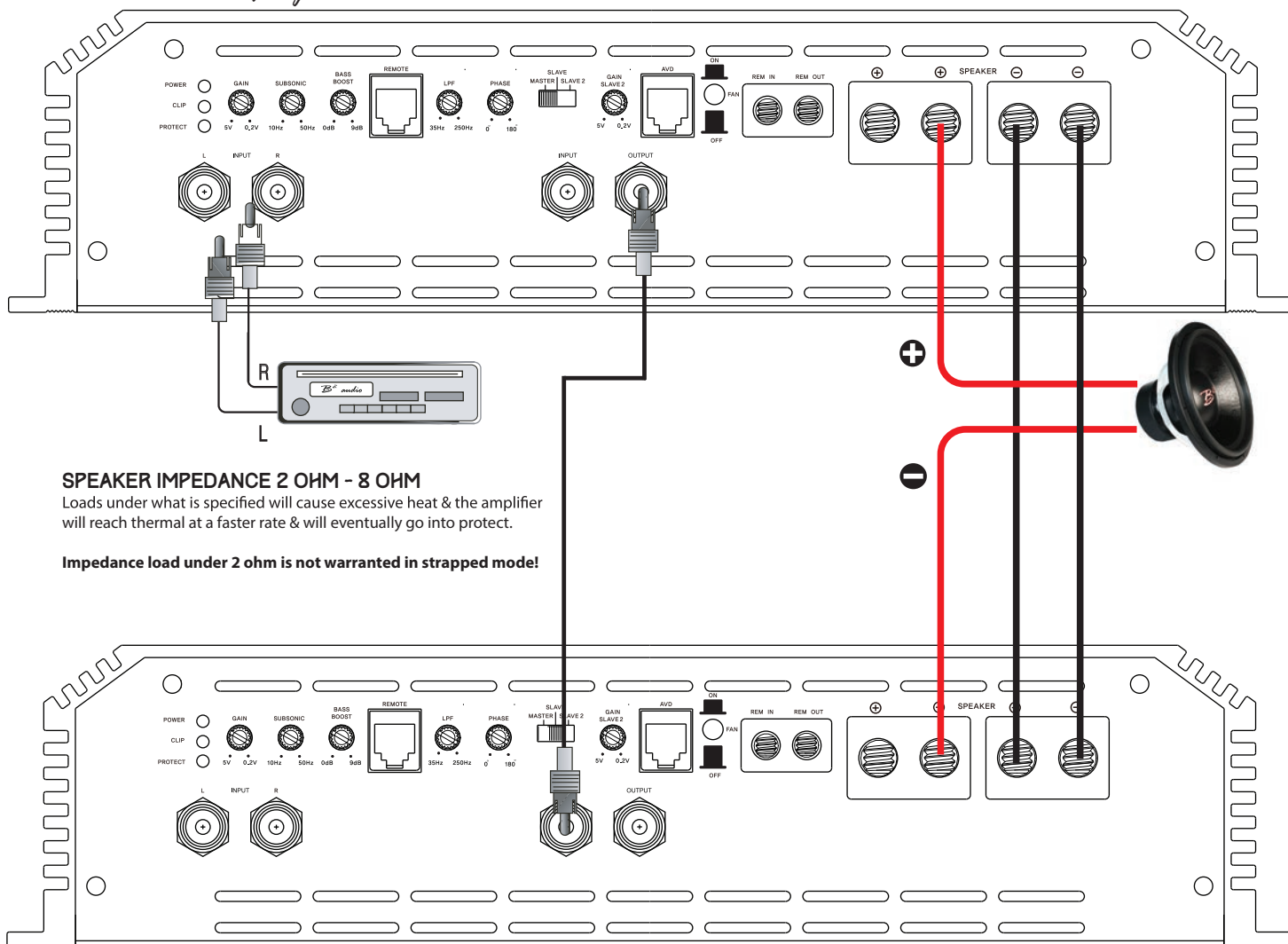

SPEAKER IMPEDANCE 2 OHM - 8 OHM

Loads under what is specified will cause excessive heat & the amplifier will reach thermal at a faster rate & will eventually go into protect.

Impedance load under 2 ohm is not warranted in strapped mode!

To link the master and slave 1 amplifier RCA connection follow the steps below.

Keep in mind amplifiers needs to be switched off, linking the amplifiers when switched on may cause harm and can void your warranty!

STEP 1. Connect RCA from Head Unit / output source into **MASTER** amplifier RCA input.
If only one output is available, then use a Y-split to connect both L & R.

STEP 2. Locate the Master / Slave switch on the right side of the control panel on the **MASTER** amplifier.
Set the switch to **MASTER** position.

STEP 3. Connect a single RCA from the **RCA OUT** on the **MASTER** amplifier.

STEP 4. Locate the Master / Slave switch on the right side of the control panel on the **SLAVE** amplifier.
Set the switch to **SLAVE** position.

STEP 5. Connect the single RCA cable from the **MASTER** amplifier's **RCA OUT** to the **SLAVE** amplifier's single **RCA IN**.

STRAPPED SPEAKER CONNECTION

STEP 1.
Run the **POSITIVE (+)** speaker cable from the **MASTER** amplifier's speaker output to the **POSITIVE TERMINAL (+)** of the subwoofer.

STEP 2.
Run the **POSITIVE (+)** speaker cable from the **SLAVE** amplifier's speaker output to the **NEGATIVE TERMINAL (-)** of the subwoofer.

STEP 3.
Connect both amplifiers together by running a cable from **NEGATIVE** speaker output on **MASTER** amplifier to **NEGATIVE** speaker output on **SLAVE** amplifier. Use minimum 8 GA cable for connecting the amplifiers.

B² audio

ACCU8 CROSSOVER & BOOST

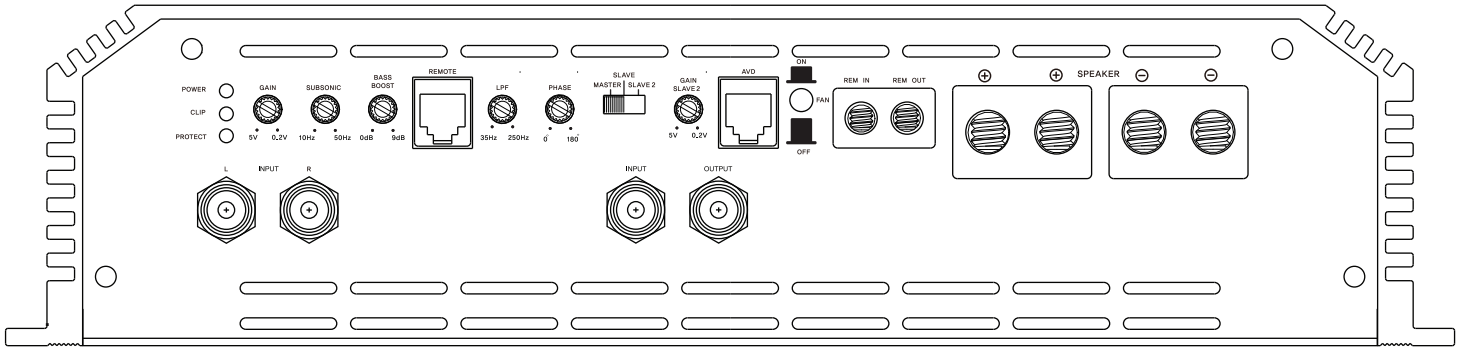

LOW PASS, BASS BOOST

The low pass crossover is 18 dB / oct. Setting it at 80 Hz will then have the signal cut off with 18 dB at 40 Hz (1 octave). To ensure accuracy for the individual crossover frequency the pot feature 41 clicks, each with a corresponding frequency. The same is valid for the bass boost settings, which also features 41 clicks. We call this feature for ACCU8.

CLICK SETTINGS FOR LPF - BASS BOOST

LPF	BOOST	LPF	BOOST	LPF	BOOST
1. 33 Hz	- 0 dB	15. 61 Hz	- 8,50 dB	29. 160 Hz	- 8,90 dB
2. 34 Hz	- 0,30 dB	16. 68 Hz	- 8,60 dB	30. 170 Hz	- 8,90 dB
3. 34 Hz	- 0,40 dB	17. 76 Hz	- 8,70 dB	31. 181 Hz	- 8,90 dB
4. 35 Hz	- 0,50 dB	18. 86 Hz	- 8,70 dB	32. 185 Hz	- 8,90 dB
5. 35 Hz	- 0,75 dB	19. 100 Hz	- 8,80 dB	33. 190 Hz	- 8,90 dB
6. 36 Hz	- 3,50 dB	20. 111 Hz	- 8,80 dB	34. 195 Hz	- 8,90 dB
7. 36 Hz	- 5,60 dB	21. 116 Hz	- 8,80 dB	35. 200 Hz	- 9,00 dB
8. 39 Hz	- 6,70 dB	22. 120 Hz	- 8,80 dB	36. 203 Hz	- 9,00 dB
9. 41 Hz	- 7,40 dB	23. 125 Hz	- 8,80 dB	37. 207 Hz	- 9,00 dB
10. 43 Hz	- 7,80 dB	24. 130 Hz	- 8,90 dB	38. 210 Hz	- 9,00 dB
11. 46 Hz	- 8,00 dB	25. 135 Hz	- 8,90 dB	39. 230 Hz	- 9,00 dB
12. 50 Hz	- 8,20 dB	26. 140 Hz	- 8,90 dB	40. 240 Hz	- 9,00 dB
13. 55 Hz	- 8,40 dB	27. 144 Hz	- 8,90 dB	41. 250 Hz	- 9,00 dB
14. 57 Hz	- 8,40 dB	28. 151 Hz	- 8,90 dB		

B² audio

TROUBLESHOOTING

The protection circuits of the amplifier prevents severe damages from faulty conditions & improper use. The protection indicator will switch on due to short circuit connection & speaker overload, thus the amplifier will be turned off. Prior to inspecting the occurred problem, turn all levels down & all power off, then carefully check the installation for wiring mistakes, shorts or faulty ground (GND). If the amplifier shuts down due to excessive heat, the protection indicator will light up; please allow time for the unit to be cooled off. Before removing your amplifier, refer to the list below and follow the suggested procedures step by step. If not at ease, contact an authorized installer which can assist you.

AMPLIFIER DOESN'T TURN ON

- Measure voltage on the +12V terminal.
- Ensure that the remote terminal has min. 13.8 V DC remote connection.
- Recheck the ground (GND) connection. Inspect the in-line fuses.
- Check the protection LED is not on.

PROTECTION LED IS LIT ONCE THE AMPLIFIER IS TURNED ON

- Check shorts on speaker wires & the connected load / impedance. Check power cables & GND.
- Disconnect the speaker cables and reset the amplifier.
- High / Low voltage, operation voltage is 9 V ~ 16 V. Voltages below / beyond this will cause the amplifier to go into protect.

FUSE BLOWING

- Measure the speaker impedance & that it is in accordance with the configuration.
- Inspect the power cable for shorts along with vehicle chassis.

OVERHEATING

- Measure the speaker impedance & that it is in accordance with the configuration.
- Check speaker shorts.
- Ensure airflow around the amplifier is sufficient & that the amplifier is not installed in areas of excessive vibration & upside down!

AUDIO OUTPUT INSUFFICIENT - DISTORTED SOUND

- Ensure that the gain settings on the amplifier is matched with the output level of the head unit.
- Adjust the head unit volume.
- Check speaker shorts.
- Adjust the crossover frequencies in accordance with the setup.
- If no output at all, check the RCA connections & the cable itself.

TURN ON THUMP

- Disconnect the signal input to the amplifier, then turn it on and off.
 - a) If the noise is cancelled, then connect a delay turn on module on the REM wire running from the source unit to the amplifier.
 - b) Use another 12V source for REM lead to the amplifier. If the noise is cancelled, use a relay to isolate the amplifier from the turn on thump.

HIGH HISS-ENGINE NOISE IN SPEAKERS

- Ensure that all signal transferring wires (RCA, speaker cables etc) are kept separately / away from the power and the ground wires.
- Bypass all electrical components between the Head unit and the amplifier.
Connect the Head unit directly to the amplifier's input. If the noise is eliminated, the unit bypassed is the one causing the noise.
- Remove the existing ground wires for all electrical components installed. Ensure that the point of ground is 100% metal which has been grinded free of rust, paint etc.
- Replace the ground cable from the OEM battery / alternator and ensure it is grounded accordingly.
- Test the battery and alternator load (can be carried out by a professional).
Ensure that the vehicle's electrical system is in a good condition, this includes distributor, alternator, spark plugs / wires, voltage regulators etc.

B² audio

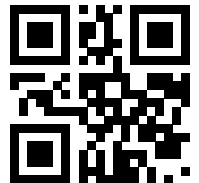

AUDIO PRECISION CHARTS

The Falcon

14.4 V - 1 ohm - 40 Hz

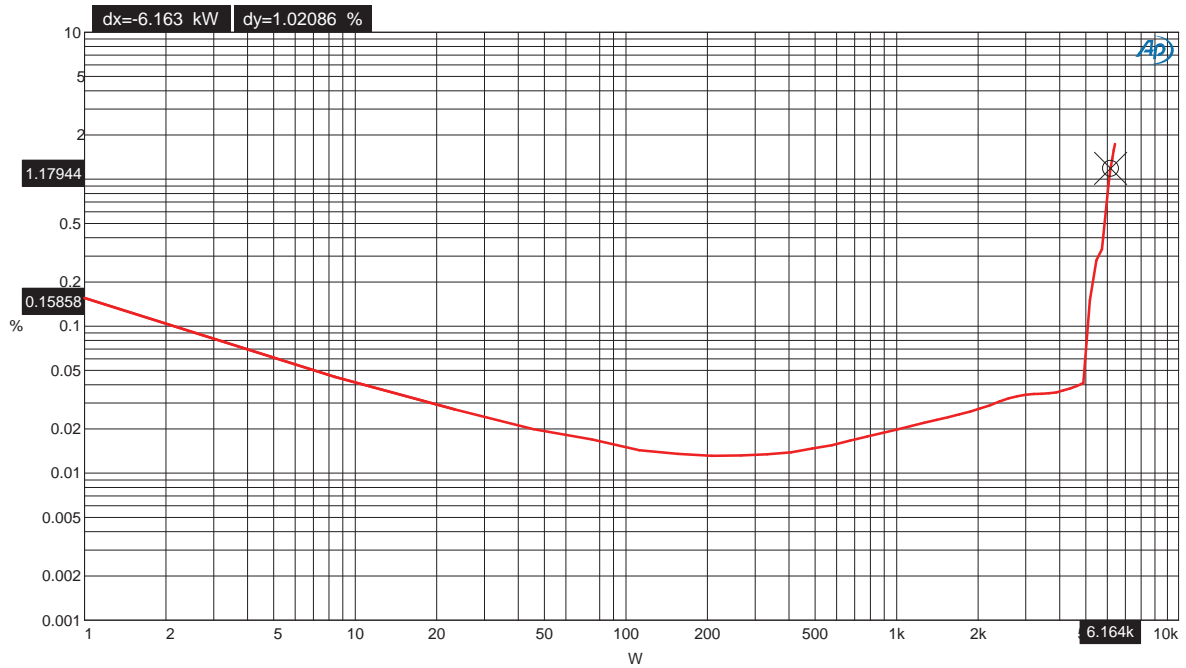

Sweep	Trace	Color	Line Style	Thick	Data	Axis	Comment	Cursor1	Cursor2
1	1	Red	Solid	8	Anlr.THd+N Ratio	Left		*1.17944 %	*0.15858 %

The Osprey

14.4 V - 1 ohm - 40 Hz

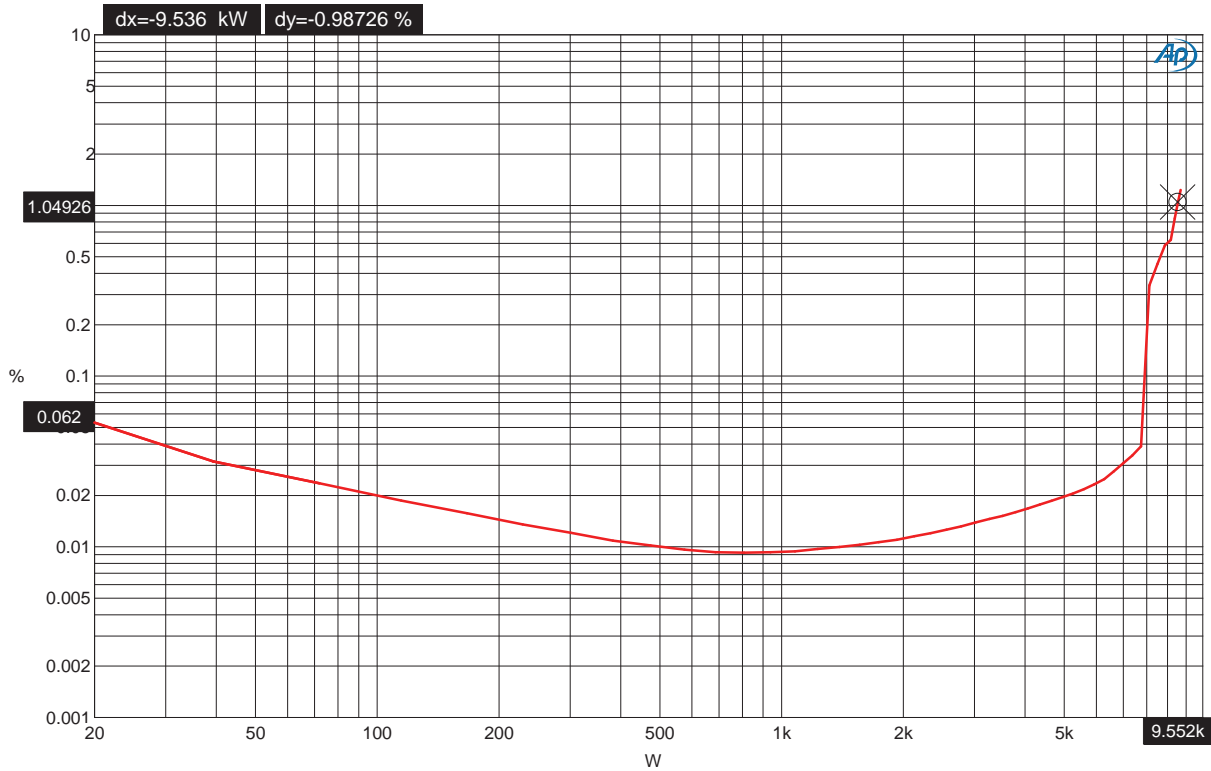

Sweep	Trace	Color	Line Style	Thick	Data	Axis	Comment	Cursor1	Cursor2
1	1	Red	Solid	8	Anlr.THd+N Ratio	Left		*1.04926 %	*0.06200 %

AUDIOPHILE ACOUSTICS

B2[®]

SWEET LIKE DANISH

LIMITED WARRANTY INFORMATION

B2 audio offers a limited warranty under the following terms:

The product is to be free of defects in material & workmanship under normal use for a period of 1 year from the date of the original purchase, when installed by an authorized dealer. Items not installed by authorized dealers will be warranted for 30 days from the original purchase. Original sales receipts must be accompanied with all returns. The warranty applies to the original purchaser of the product & it being sold by authorized B2 audio dealers.

- The warranty does not cover:
1. Damage caused by accident, abuse, misuse, improper operation, water / solvents & shipping.
 2. Product modification, neglect, failure to follow installation instructions & misrepresentation by the seller.
 3. Products used for competition purposes or are of such a character 4. Any product that has been opened.
 5. Products that has had the serial number defaced, altered or removed.
 6. The cost of shipping the product back for repair to an authorized repair centre & cost of return of non-defective items.

