

The data to be read in conjunction with the Hydrogen Thyatron Preamble.

ABRIDGED DATA

Hydrogen filled, double-gap, hollow anode thyatron with ceramic envelope, featuring high peak current, high rate of rise of current and low jitter, developed specifically for use in the low inductance circuits associated with excimer lasers.

A reservoir operated from a separate heater supply is incorporated. The reservoir heater voltage can be adjusted to a value consistent with anode voltage hold-off in order to achieve the fastest rate of rise of current possible from the tube in the circuit.

Peak forward anode voltage	40	kV max
Peak forward anode current	10	kA max
Peak reverse anode current	5.0	kA max
Average anode current	0.5	A max
Pulse repetition rate	200	Hz max

GENERAL

Electrical

Cathode (connected internally to one end of heater)	oxide coated
Cathode heater voltage	6.6 ± 0.2 V
Cathode heater current	24 A
Reservoir heater voltage (see note 1)	5.2 to 6.5 V
Reservoir heater current (at 6.3 V)	8 A
Tube heating time (minimum)	10 min

Mechanical

Seated height	180 mm (7.087 inches) nom
Clearance required below mounting flange	50.8 mm (2.000 inches) min
Overall diameter (mounting flange)	111.1 mm (4.375 inches) nom
Net weight	2.2 kg (4.75 pounds) approx
Mounting position (see note 2)	any
Tube connections	see outline

Cooling

For all applications, either forced-air cooling or total liquid immersion cooling is needed. For forced-air cooling, it is recommended that air be directed at both the anode and the cathode flange as indicated in Fig. 1.

Maximum temperature of envelope	150 °C
---	--------



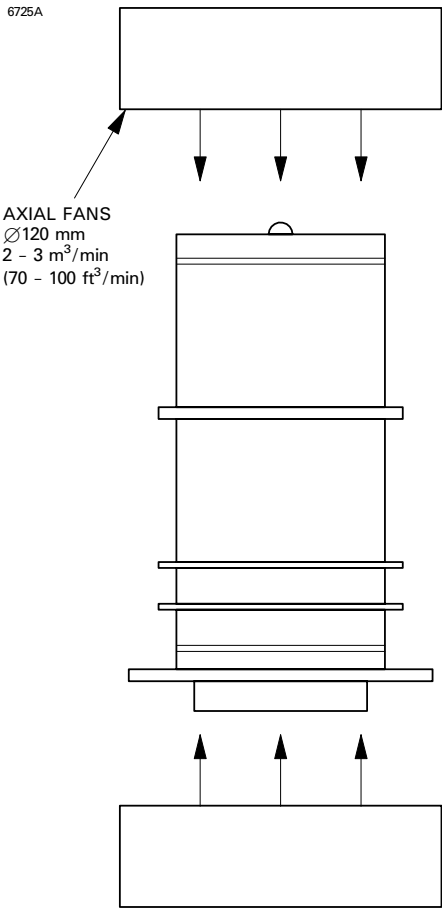

Fig. 1. Recommended cooling arrangement

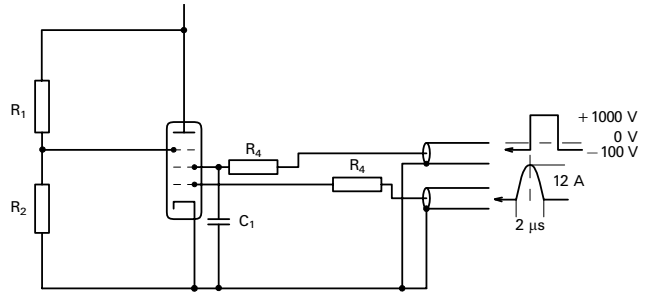

Fig. 2a. Recommended grid circuit for double pulse triggering

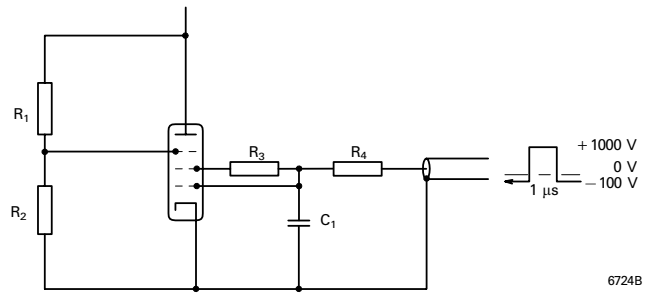

Fig. 2b. Recommended grid circuit for single pulse triggering

Recommended Values

- $R_1 = R_2 = 10\text{ M}\Omega$ High voltage resistors of sufficient power rating for operating anode voltage.
- $R_3 = 1000\ \Omega$ 12 W Vitreous enamelled wirewound.
- $R_4 = 100\ \Omega$ 12 W Vitreous enamelled wirewound.
- $C_1 = 2.7\text{ nF}$ Ceramic disc capacitor rated to 10 kV min.

Note It is recommended that R_3 , R_4 and C_1 be mounted as close to the tube as possible.

PULSE LASER SERVICE

MAXIMUM AND MINIMUM RATINGS (Absolute values)

	Min	Typical	Max	
Anode				
Peak forward anode voltage (see note 3)	—	—	40	kV
Peak forward anode current	—	—	10	kA
Peak reverse anode current	—	—	5.0	kA
Average anode current	—	—	0.5	A
Pulse duration	—	—	0.5	μs

Triggering

The CX2608 has two trigger grids, designated grid 1 and grid 2 (see outline drawing). For maximum lifetime, it is recommended that the CX2608 be triggered with two independent pulses to grids 1 and 2 as indicated in Fig. 2a. The CX2608 will however operate satisfactorily with a single pulse as indicated in Fig. 2b.

Single Pulse Triggering (see Fig. 2b)

Unloaded grid drive voltage (see note 4)	800	1000	2000	V
Grid pulse duration	—	1	—	μs
Rate of rise of grid pulse voltage (see notes 5 and 6)	4	10	—	kV/ μs
Loaded grid 2 bias voltage	-50	-100	-150	V
Source impedance of grid drive circuit (see note 7)	50	100	200	Ω

Double Pulse Triggering (See Fig. 2a)

Grid 1 (Current driven)

Unloaded grid 1 voltage	300	500	2000	V
Loaded grid 1 current	8	12	20	A
Grid 1 pulse duration	1	2	5	μ s
Peak inverse grid 1 voltage	—	—	—450	V
Rate of rise of grid 1 pulse	0.5	1	5	kV/ μ s

Grid 2 (Voltage driven)

Unloaded grid 2 voltage (see note 4)	500	1000	2000	V
Grid 2 pulse duration	0.5	1.0	2.0	μ s
Rate of rise of grid 2 pulse (see notes 5 and 6)	4	10	—	kV/ μ s
Loaded grid 2 bias voltage	—50	—100	—150	V
Forward impedance of grid 2 drive circuit	50	100	200	Ω
Grid 2 timing delay	see note 8 and Fig. 2a			

Heaters

Cathode heater voltage	6.4	6.6	6.8	V
Reservoir heater voltage	5.2	5.6	6.5	V
Tube heating time	10	—	—	min

Environmental

Ambient temperature	—50	—	+90	$^{\circ}$ C
Altitude	—	—	3	ft
	—	—	10 000	km

CHARACTERISTICS

Critical DC anode voltage for conduction (see note 9)	—	1.0	2.0	kV
Anode delay time (see notes 9 and 10)	—	0.15	0.4	μ s
Anode delay time drift (see notes 9 and 11)	—	20	100	ns
Time jitter (see note 9)	—	2.0	5.0	ns
Cathode heater current (at 6.6 V)	—	24	—	A
Reservoir heater current (at 6.3 V)	—	8.0	—	A

NOTES

- The reservoir heater must be supplied from a variable supply independent of the cathode heater supply. The recommended reservoir operating voltage for operation at 40 kV anode voltage is stamped on the tube.
The optimum reservoir voltage is the maximum which is consistent with forward anode voltage hold-off, provided this does not exceed 6.5 V.
- The tube must be fitted using its mounting flange.
- The maximum permissible peak forward voltage for instantaneous starting is 40 kV and there must be no overshoot.
- Measured with respect to cathode.
- This rate of rise refers to that part of the leading edge of the pulse between 25% and 75% of the pulse amplitude.
- A lower rate of rise may be used, but this may result in the anode delay time, delay time drift and jitter exceeding the limits quoted.
- During the drive pulse period and during recovery when the current flow is reversed.
- It is recommended that the start of the grid 2 pulse coincides with the peak of the grid 1 current pulse. The minimum permissible grid 2 delay with respect to the grid 1 pulse is 0.25 μ s.
- Typical figures are obtained on test using conditions of minimum grid drive. Improved performance can be expected by increasing grid drive.
- The time interval between the instant at which the rising unloaded grid 2 pulse reaches 25% of its pulse amplitude and the instant when anode conduction takes place.
- The drift in delay time over a period from 10 seconds to 10 minutes after reaching full voltage.

OUTLINE

(All dimensions without limits are nominal)

6732A

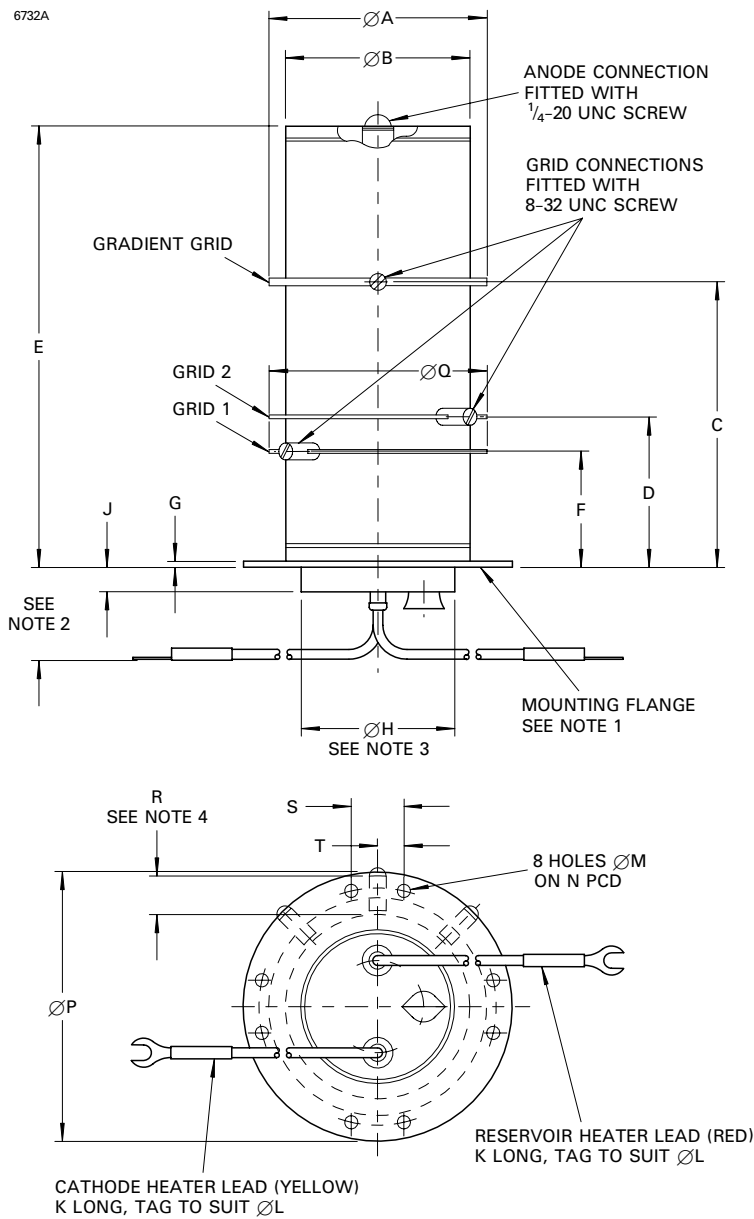

Ref	Millimetres	Inches
A	90.0	3.543
B	77.80 max	3.063 max
C	117.82	4.639
D	62.06	2.443
E	180.0 ± 2.0	7.087 ± 0.079
F	47.76	1.880
G	2.5	0.098
H	69.85 max	2.750 max
J	12.70 max	0.500 max
K	190.50 min	7.500 min
L	6.35	0.250
M	5.5	2.17
N	98.07	3.861
P	111.13	4.375
Q	92.5	3.642
R	16.0	0.630
S	21.74	0.856
T	10.87	0.428

Inch dimensions have been derived from millimetres.

Outline Notes

1. The mounting flange is the connection for the cathode, cathode heater return and reservoir heater return.
2. A minimum clearance of 50.8 mm (2.000 inches) must be allowed below the mounting flange.
3. The recommended mounting hole is 73.03 mm (2.875 inches) diameter.
4. This dimension applies to all three grid connections.

HEALTH AND SAFETY HAZARDS

E2V Technologies hydrogen thyratrons are safe to handle and operate provided that the relevant precautions stated herein are observed. E2V Technologies does not accept responsibility for damage or injury resulting from the use of electronic devices it produces. Equipment manufacturers and users must ensure that adequate precautions are taken. Appropriate warning labels and notices must be provided on equipments incorporating E2V Technologies devices and in operating manuals.

High Voltage

Equipment must be designed so that personnel cannot come into contact with high voltage circuits. All high voltage circuits and terminals must be enclosed and fail-safe interlock switches

must be fitted to disconnect the primary power supply and discharge all high voltage capacitors and other stored charges before allowing access. Interlock switches must not be bypassed to allow operation with access doors open.

X-Ray Radiation

All high voltage devices produce X-rays during operation and may require shielding. The X-ray radiation from hydrogen thyratrons is usually reduced to a safe level by enclosing the equipment or shielding the thyratron with at least 1.6 mm (¹/₁₆ inch) thick steel panels.

Users and equipment manufacturers must check the radiation level under their maximum operating conditions.

Whilst E2V Technologies has taken care to ensure the accuracy of the information contained herein it accepts no responsibility for the consequences of any use thereof and also reserves the right to change the specification of goods without notice. E2V Technologies accepts no liability beyond that set out in its standard conditions of sale in respect of infringement of third party patents arising from the use of tubes or other devices in accordance with information contained herein.