

# 3.0V 3400F ULTRACAPACITOR CELL BCAP3400 P300 K04/05

## Maxwell's Highest Power and Energy Cell



Maxwell Technologies' 3V 3400F ultracapacitor cell is designed to support the latest trends in renewable energy, industrial electrification and transportation. Designed from the ground up, Maxwell developed the 3V 3400F cell to be the highest energy, highest power workhorse of its ultracapacitor portfolio. Whether used alone, integrated into a module assembly, or in a hybrid configuration, Maxwell's 3V 3400F product will help reduce the overall cost and weight of the system while improving the customer's return on investment.

Ultracapacitors are the technology of choice for high energy and high power applications because of their long operating lifetime, low maintenance requirements and superior cold weather performance; when compared to batteries.

### FEATURES AND BENEFITS

- High power and high energy
- 30 kW/kg of specified power
- 4.25 Wh of stored energy
- DuraBlue™ Shock and Vibration Technology
- Up to 1,000,000 duty cycles or 10-year DC life\*
- Laser weldable or screw posts

### TYPICAL APPLICATIONS

- Heavy transportation
  - Hybrid buses
  - Rail
  - Truck
  - Construction vehicles
- Heavy industrial and stationary solutions
  - Backup and UPS systems
- Grid and microgrid

### ORDERING INFORMATION

Model Number	Part Number	Package Quantity
BCAP3400 P300 K04/05	134144 / 134874	15

## PRODUCT SPECIFICATIONS

Values are referenced at  $T_A$  = room temperature and  $V_R$  = 3.0V rated voltage (unless otherwise noted). Min and Max values indicate product specifications. Typical results will vary and are provided for reference. Additional terms and conditions, including the limited warranty, apply at the time of purchase.

Symbol	Parameter	Conditions	Min	Typical	Max	Unit
<b>ELECTRICAL</b>						
$C_R$	Initial Rated Capacitance	Note 3	3,400	–	4,080	F
$R_S$	Initial Equivalent Series Resistance (ESR)	100ms, Note 3	–	0.15	0.24	mΩ
$V_R$	Maximum Rated Voltage		–	3.0	–	V
$V_{MAX}$	Absolute Maximum Voltage	Note 1	–	–	3.15	V
$I_{DCMAX}$	Maximum Continuous Current	Note 8, 10 - $\Delta T = 15^\circ\text{C}$ (BOL) - $\Delta T = 40^\circ\text{C}$ (BOL)	– –	140 225	– –	$A_{RMS}$
$I_{ACMAX}$	Maximum Peak Current	Note 5	–	–	2,800	A
$I_{SHORT}$	Short Circuit Current	Current possible with short circuit from $V_R$ . Do not use as operating current.	–	20,000	–	A
$I_{LEAK}$	Leakage Current	At $25^\circ\text{C}$ , Note 4	–	–	12	mA
<b>LIFE</b>						
$t_{AGING}$	Accelerated Aging	At $V_R = 3\text{V}$ and $T_A = 65^\circ\text{C}$ (note 3,10) - Capacitance change $\Delta C$ from $C_R$ - Resistance change $\Delta R$ from $R_S$	– – –	1,500 20 100	– – –	hours % %
$t_{LIFE}$	Projected Life Time	At $V_R = 3\text{V}$ and $T_A = 25^\circ\text{C}$ (note 3,10) - Capacitance change $\Delta C$ from $C_R$ - Resistance change $\Delta R$ from $R_S$	– – –	10 20 100	– – –	years % %
$n_{LIFE}$	Projected Cycle Life	At $V_R = 3\text{V}$ and $T_A = 25^\circ\text{C}$ (note 3,7,10) - Capacitance change $\Delta C$ from $C_R$ - Resistance change $\Delta R$ from $R_S$	– – –	1,000,000 25 100	– – –	cycles % %
$t_{SHELF}$	Shelf Life	Stored uncharged at $25^\circ\text{C}$ , <50% RH	–	4	–	years
<b>POWER &amp; ENERGY</b>						
$P_d$	Usable Specific Power	Note 6	9.07	14.5	–	kW/kg
$P_{max}$	Impedance Match Specific Power	Note 6	18.9	30	–	kW/kg
$E_{MAX}$	Specific Energy	Note 6	8.57	–	–	Wh/kg
$E_{STORED}$	Stored Energy	Note 6, 9	4.25	–	–	Wh

\*Results may vary. Additional terms and conditions, including the limited warranty, apply at the time of purchase. See the warranty details for applicable operating and use requirements.

**PRODUCT SPECIFICATIONS, cont.**

Symbol	Parameter	Conditions	Min	Typical	Max	Unit
--------	-----------	------------	-----	---------	-----	------

**TEMPERATURE**

T <sub>A</sub>	Operating Temperature	Cell Case Temperature	-40	–	65	°C
T <sub>STG</sub>	Storage Temperature	Stored Uncharged @ <50% Relative humidity (RH)	–	–	25	°C
R <sub>th</sub>	Thermal Resistance	Case to Ambient, Note 8	–	3.2	–	°C/W
C <sub>th</sub>	Thermal Capacitance		–	580	–	J/°C

**PHYSICAL**

m	Mass		–	496	–	g
F <sub>M12</sub>	Recommended Torque on Threaded Connectors (K04)	M12 Thread	10	12	14	Nm
–	Recommended Welding on Jove Terminal (K05)	Negative = 1100-F aluminum Positive = 1070-F aluminum Refer to Maxwell K2 Cell Family Welding Guidelines (www.maxwell.com)	–	–	–	–
–	Vibration Specification		ISO 16750-3 (Table 12)			–
–	Shock Specification		IEC60068-2-27			–

**SAFETY**

–	Certifications		UL810a, RoHS, REACH			
---	----------------	--	---------------------	--	--	--

**TEST PROCEDURES**

- Surge Voltage  
Absolute maximum voltage, non-repetitive. Duration not to exceed 1 second.
- “Typical” values represent mean values of production sample.
- Capacitance and ESR<sub>DC</sub> measured using 100 A test current at 25°C per document number 1007239 available at maxwell.com.
- Maximum Leakage Current
  - Current measured after 72 hrs at rated voltage and 25°C. Initial leakage current can be higher.
  - If applicable, module leakage current is the sum of cell and balancing circuit leakage currents.
- Maximum Peak Current
  - Current needed to discharge cell/module from rated voltage to half-rated voltage in 1 second.
  - $$I = \frac{\frac{1}{2}V_R}{\Delta t / C + ESR_{DC}}$$
 where Δt is the discharge time (sec); Δt = 1 sec in this case.
  - The stated maximum peak current should not be used in normal operation and is only provided as a reference value.
- Energy & Power (Based on IEC 62391-2)
  - Maximum Stored Energy, E<sub>max</sub> (Wh) =  $\frac{\frac{1}{2}CV_R^2}{3,600}$
  - Gravimetric Specific Energy (Wh/kg) =  $\frac{E_{max}}{mass}$

- Usable Specific Power (W/kg) =  $\frac{0.12V_R^2}{ESR_{DC} \times mass}$
  - Impedance Match Specific Power (W/kg) =  $\frac{0.25V_R^2}{ESR_{DC} \times mass}$
  - Presented Power and Energy values are calculated based on Rated Capacitance & Rated (Max.) ESR<sub>DC</sub>, Initial values.
- Cycle Life Test Profile  
Cycle life varies depending upon application-specific characteristics. Actual results will vary.
  - Temperature Rise at Constant Current
    - $$\Delta T = I_{RMS}^2 \times ESR_{DC} \times R_{th}$$
 where ΔT: Temperature rise over ambient (°C)  
 I<sub>RMS</sub>: Maximum continuous or RMS current (A)  
 R<sub>th</sub>: Thermal resistance, cell to ambient (°C/W)  
 ESR<sub>DC</sub>: Rated (Max.) ESR<sub>DC</sub> (Ω).  
 (Note: Design should consider EOL ESR<sub>DC</sub> for application temperature rise evaluation.)
  - Per United Nations material classification UN3499, all Maxwell ultracapacitors have less than 10 Wh capacity to meet the requirements of Special Provisions 361. Both individual ultracapacitors and modules composed of those ultracapacitors shipped by Maxwell can be transported without being treated as dangerous goods (hazardous materials) under transportation regulations.
  - BOL: Beginning of Life, rated initial product performance  
EOL: End of Life criteria.
    - Capacitance: 80% of min. BOL rating
    - ESR<sub>DC</sub>: 2x max. BOL rating

## TYPICAL PERFORMANCE

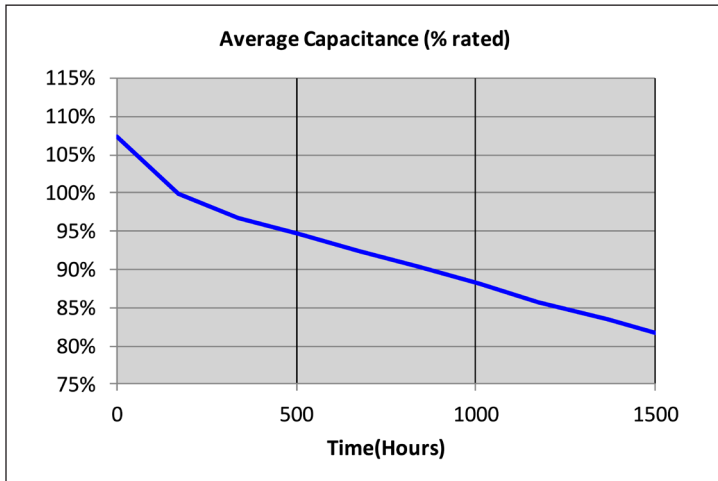

Figure 1: Accelerated Aging Capacitance Performance  
 $V_R = 3V, T_A = 65^\circ C$

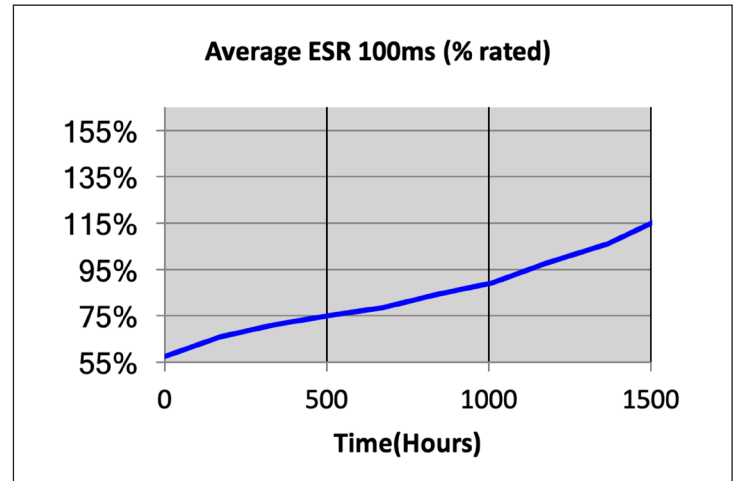

Figure 2: Accelerated Aging ESR Performance  
 $V_R = 3V, T_A = 65^\circ C$

## DETAILED PRODUCT DESCRIPTION

### Introduction

The BCAP3400 P300 K04/K05 energy storage cell is a high power and energy design in the Maxwell driven industry-standard 60mm cylindrical form factor. The 3.0V 3400F cell design uses Maxwell's proprietary DuraBlue<sup>®</sup> Advanced Shock and Vibration technology to provide maximum vibration resistance and shock immunity.

### Technology Overview

Electrochemical double layer capacitors (EDLCs), are also known as electric double layer capacitor, supercapacitors or ultracapacitors. They deliver energy at relatively high rates (beyond those accessible with batteries). Ultracapacitors store charge electrostatically (non-Faradaic) by reversible absorption of the electrolyte onto electrochemically stable high surface area carbon electrodes. Charge separation occurs on polarization at the electrode/electrolyte interface, producing a double layer. This mechanism is highly reversible, allowing the ultracapacitor to be charged and discharged hundreds of thousands to even millions of times.

### Ultracapacitor Construction

An ultracapacitor is constructed with symmetric carbon positive and negative electrodes separated by an insulating ion-permeable separator, packaged into a container then filled with organic electrolyte (salt/solvent) designed to maximize ionic conductivity and electrode wetting. It is the combination of high surface-area activated carbon electrodes (typically >1500m<sup>2</sup> /g) with extremely small charge separation (Angstroms) that results in high capacitance.

$$\text{Ultracapacitor Energy} = \frac{1}{2} CV^2$$

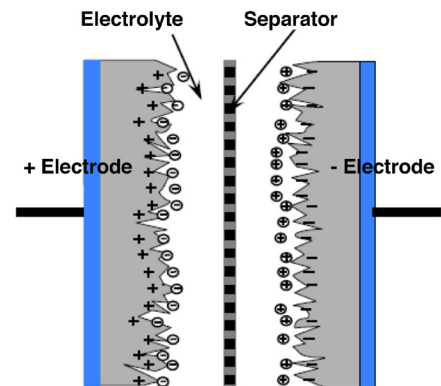
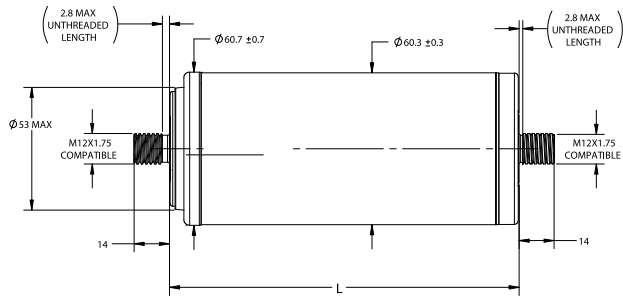

Figure 3: Ultracapacitor Structure Diagram

## MECHANICAL DRAWINGS

BCAP3400 P300 K04



BCAP3400 P300 K05

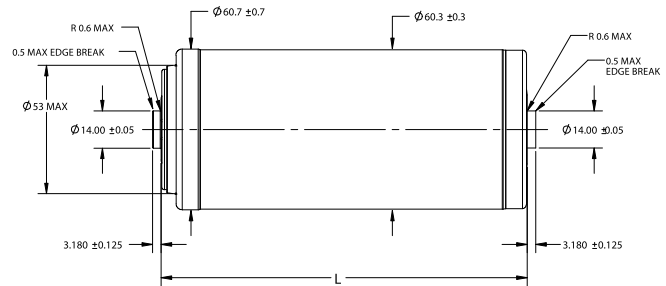

DIMENSIONS	Min	Typical	Max	Unit
Length (L)	-0.3	138	+0.3	mm

Products and related processes may be covered by one or more U.S. or international patents and pending applications. Please see [www.maxwell.com/patents](http://www.maxwell.com/patents) for more information. Product dimensions are for reference only unless otherwise identified. Maxwell Technologies reserves the right to make changes without further notice to any products herein. "Typical" parameters which may be provided in Maxwell Technologies datasheets and/or specifications can and do vary in different applications and actual performance may vary over time. All operating parameters, including "Typicals" must be validated for each customer application by customer's technical experts. Please contact Maxwell Technologies directly for any technical specifications critical to application.

**Maxwell Technologies, Inc.**  
Global Headquarters  
3888 Calle Fortunada  
San Diego, CA 92123  
USA  
Tel: +1 (858) 503-3300  
Fax: +1 (858) 503-3301

**Maxwell Technologies SA**  
Route de Montena 65  
CH-1728 Rossens  
Switzerland  
Tel: +41 (0)26 411 85 00  
Fax: +41 (0)26 411 85 05

**Maxwell Technologies, GmbH**  
Leopoldstrasse 244  
80807 Munich  
Germany  
Tel: +49 (0)89 4161403 0  
Fax: +49 (0)89 4161403 99

**Maxwell Technologies Shanghai Trading Co., Ltd.**  
Room 1005, 1006, and 1007  
No. 1898, Gonghexin Road,  
Jin An District, Shanghai 2000072,  
P.R. China  
Tel: +86 21 3852 4000  
Fax: +82 21 3852 4099

**Nesscap Co., Ltd.**  
17, Dongtangiheung-ro  
681 Beon-gil, Giheung-gu,  
Yongin-si, Gyeonggi-do 17102  
Republic of Korea  
Tel: +82 31 289 0721  
Fax: +82 31 286 6767

MAXWELL TECHNOLOGIES, MAXWELL, MAXWELL CERTIFIED INTEGRATOR, ENABLING ENERGY'S FUTURE, DURABLU, NESSCAP, XP, BOOSTCAP, D CELL, CONDIS and their respective designs and/or logos are either trademarks or registered trademarks of Maxwell Technologies, Inc., and/or its affiliates, and may not be copied, imitated or used, in whole or in part, without the prior written permission Maxwell Technologies, Inc. All contents copyright © 2018 Maxwell Technologies, Inc. All rights reserved. No portion of these materials may be reproduced in any form, or by any means, without prior written permission from Maxwell Technologies, Inc.