

The data to be read in conjunction with the Hydrogen Thyatron Preamble.

## ABRIDGED DATA

Deuterium-filled, two-gap thyratrons with metal/ceramic envelopes, suitable for switching high peak and average power at high pulse repetition rates. A reservoir operating from the cathode heater supply or a separate supply is incorporated.

The CX1836/CX1836X has three control grids which can be configured to enable the tube to operate both as a standard modulator switch with or without trigger grid negative bias, and also as a command charge switch where a high level of immunity to spurious triggering is required.

The CX1836X, which must be used in conjunction with Teledyne e2v resistor box MA942A, permits a larger variation in internal deuterium pressure than the CX1836. Resistor box settings and/or reservoir heater voltage can be adjusted within the specified limits to obtain the maximum thyatron gas pressure consistent with the required voltage hold-off.

Peak forward anode voltage	-	70 kV max
Peak forward anode current	-	10 kA max
Average anode current	-	10 A max
Operating frequency (see note 1)	-	10 kHz max 50 Hz min

## GENERAL DATA

### Electrical

Cathode	-	Barium aluminate impregnated tungsten
Cathode heater voltage (see note 2)	-	6.3 ± 5% V
Cathode heater current	-	90 A
Reservoir heater voltage (see notes 2 and 3)	-	6.3 ± 5% V
Reservoir heater current	-	7.0 A
Tube heating time (minimum)	-	10 min
Anode to gradient grid capacitance	-	45 pF
Gradient grid to grid 2 capacitance	-	45 pF

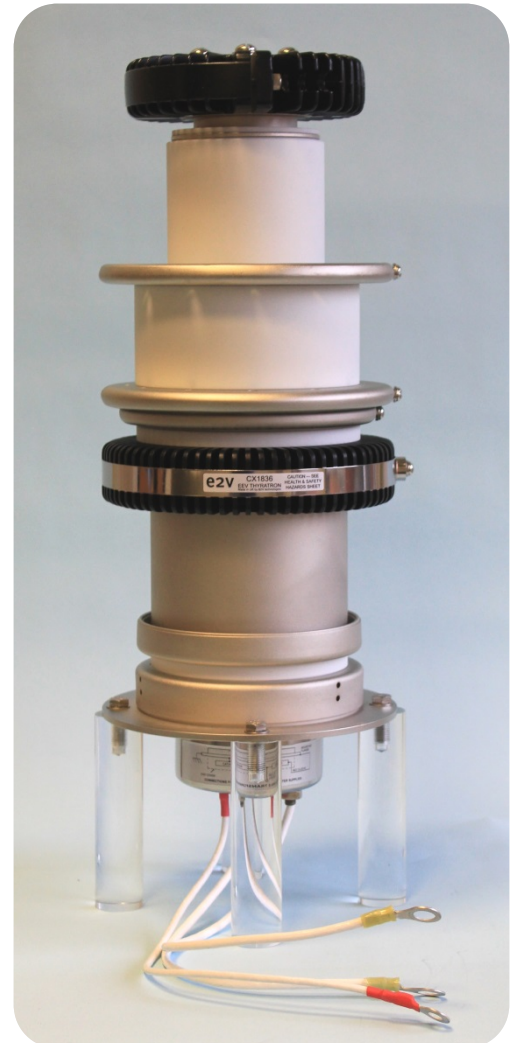

### Mechanical

Seated height	-	336 mm (13.228 inches) max
Clearance required below mounting flange	-	75 mm (2.953 inches) min
Overall diameter (mounting flange)	-	155.4 mm (6.118 inches) max
Net weight	-	11.4 kg (26.2 pounds) approx.
Mounting position	-	See note 4
Tube connections	-	See outline

Whilst Teledyne e2v has taken care to ensure the accuracy of the information contained herein it accepts no responsibility for the consequences of any use thereof and also reserves the right to change the specification of goods without notice. Teledyne e2v accepts no liability beyond that set out in its standard conditions of sale in respect of infringement of third party patents arising from the use of tubes or other devices in accordance with information contained herein.

Teledyne e2v (UK) Limited, Waterhouse Lane, Chelmsford, Essex CM1 2QU United Kingdom Teledyne e2v (UK) Ltd. is a Teledyne Technologies company.

Telephone: +44 (0)1245 493493 Facsimile: +44 (0)1245 492492

Contact Teledyne e2v by e-mail: [Enquiries@Teledyne-e2v.com](mailto:Enquiries@Teledyne-e2v.com) or visit [www.teledyne-e2v.com](http://www.teledyne-e2v.com) for global sales and operations centres.

© Teledyne e2v (UK) Limited 2018

Template: DF764388A Ver 16

A1A-CX1836\_CX1836X Version 7, September 2018

126447

## Cooling

The tube must be cooled by total liquid immersion, for example in force circulated transformer oil (see Teledyne e2v Reprint No. 108 'The cooling of oil-filled electrical equipment, with special reference to high power line-type pulse generators' by G. Scoles). Care must be taken to ensure that air is not trapped inside the tube end cover.

In pulse modulator service, the tube dissipates 600 W of heater power and from 100 W/A average anode current, rising to 300 W/A at the highest rates of rise and fall of anode current.

## PULSE MODULATOR SERVICE

### MAXIMUM AND MINIMUM RATINGS

These ratings cannot necessarily be used simultaneously, and no individual rating must be exceeded.

Anode	Min	Max	
Peak forward anode voltage (see note 5)	-	70	kV
Peak inverse anode voltage (see note 6)	-	70	kV
Peak anode current	-	10	kA
Average anode current	-	10	A
Rate of rise of anode current (see notes 7 and 8)	-	10	kA/μs

### Gradient Grid

Connected in accordance with diagram - See page 6

Trigger Pulse	Min	Max	
Unloaded trigger pulse voltage (see note 9)	1000	2000	V
Trigger pulse duration	1.0	-	μs
Rate of rise of trigger pulse (see notes 7 and 10)	10.0	-	kV/μs
Trigger pulse delay (see note 11)	0.5	3.0	μs
Peak inverse trigger voltage	-	450	V
Loaded trigger pulse bias voltage (see note 12)	0	-200	V
Peak trigger pulse drive current:			
With grid 3 as screen grid (see note 13)	125	175	A
In modulator service	5	40	A

Pre-pulse (Grid 1) (see note 14)	Min	Max	
Unloaded drive pulse voltage	600	2000	V
Grid 1 pulse duration	2.0	-	μs
Rate of rise of grid 1 pulse	1.0	-	kV/μs
Peak inverse grid 1 voltage	-	450	V
Loaded grid 1 bias voltage	See note 15		
Peak grid 1 drive current	5	100	A

Cathode	Min	Max	
Heater voltage	6.3 ± 5%		V
Heating time	10	-	min

Reservoir	Min	Max	
Heater voltage	6.3 ± 5%		V
Heating time	10	-	min

Environmental	Min	Max	
Ambient air temperature	0	+40	°C

## CHARACTERISTICS

	Min	Typ	Max	
Critical DC anode voltage for conduction	-	-	5.0	kV
Anode delay time	-	200	350	ns
Anode delay time drift (see note 16)	-	15	25	ns
Time jitter (see note 17)	-	3.0	10	ns
Recovery time (see notes 1 and 18)	-	20	-	μs
Cathode heater current (at 6.3 V)	80	90	100	A
Reservoir heater current (at 6.3 V)	6.0	7.0	8.0	A

# NOTES

- The CX1836/CX1836X has a short recovery time for a tube of its size. However, due to the open grid structure giving the high peak current switching capability, the high voltage hold-off performance of this tube is limited at low operating frequencies.

In order to maximise tube performance and to overcome completely the limited high voltage hold-off ability at low frequency, command charging techniques must be used to limit the time high voltage is applied to the anode to a maximum of 20 ms.

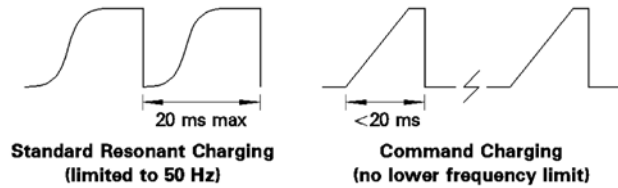

- It is recommended that the cathode heater and the reservoir heater are supplied from independent power supplies. **The common connection for these two supplies is the pair of yellow sleeved leads, not the cathode flange.**

**N.B. The tube will suffer irreversible damage if the cathode flange is connected as the common point.**

The cathode heater supply must be connected between the cathode flange and the cathode heater leads (yellow sleeves), the reservoir heater supply must be connected between the cathode heater leads (yellow sleeves) and the reservoir heater lead (red sleeve), see Figs. 1 and 2. In order to meet the jitter specification, it may be necessary in some circumstances that the cathode heater be supplied from a DC source.

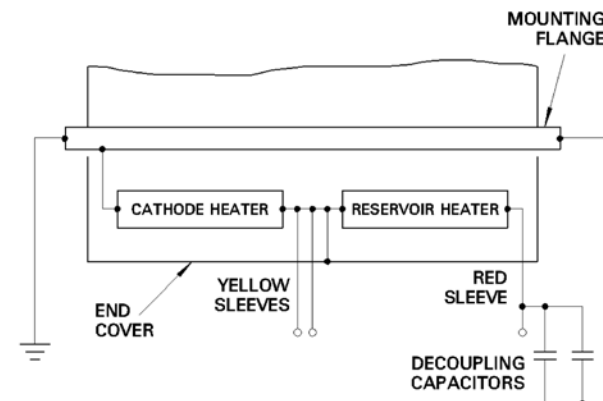

**Fig. 1 CX1836 base connections**

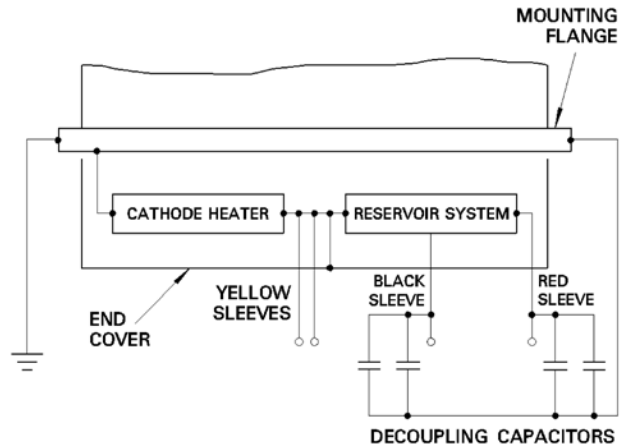

**Fig. 2 CX1836X base connections**

Care should be taken to ensure that excessive voltages are not applied to the reservoir heater circuit from the cathode heater supply because of high impedance cathode heater connections. For example, in the worst case, an open circuit heater lead will impress almost double voltage on the reservoir heater, especially on switch-on, when the cathode heater impedance is minimal. This situation can be avoided by ensuring that the two supplies are in anti-phase. The reservoir heater circuit must be decoupled with suitable capacitors, for example, a 1  $\mu\text{F}$  capacitor in parallel with a low inductance 1000 pF capacitor.

The heater supply systems should be connected directly between the cathode flange and the heater leads. This avoids the possibility of injecting voltages into the cathode and reservoir heaters. At high rates of rise of anode current, the cathode potential may rise significantly at the beginning of the pulse, depending on the cathode lead inductance, which must be minimised at all times.

If a single transformer is used to supply both the cathode heater and the reservoir heater, then the reservoir heater lead (red sleeve) must be connected to the mounting flange.

- CX1836X gas pressure may be altered using Teledyne e2v resistor box type MA942A. The CX1836X **must** be used in conjunction with the MA942A. The resistor box must be connected between the reservoir monitor lead (black sleeve) and the cathode heater lead (yellow sleeve). Gas pressure may be increased by increasing the resistor box settings from their initial recommended values which accompany each delivered CX1836X.

The gas pressure may be increased to a value consistent with the required forward hold-off voltage. Additional variations in gas pressure can be achieved by altering the reservoir power supply voltage within the specified range.

- The tube must be fitted using its mounting flange, with flexible connections to all other electrodes.

The preferred orientation is with the tube axis vertical and anode uppermost; mounting the tube with its axis horizontal is permissible. It is not recommended that the tube is mounted with its axis vertical and cathode uppermost.

5. The maximum permissible peak forward voltage for instantaneous starting is 50 kV and there must be no overshoot.
6. The peak inverse voltage including spike must not exceed 10 kV for the first 25 $\mu$ s after the anode pulse. Amplitude and rate of rise of inverse voltage contribute greatly to tube dissipation and electrode damage; if these are not minimised in the circuit, tube life will be shortened considerably. The aim should be for an inverse voltage of 3-5 kV peak with a rise time of 0.5  $\mu$ s.
7. This rate of rise refers to that part of the leading edge of the pulse between 25% and 75% of the pulse amplitude.
8. For single-shot or burst mode applications this parameter can exceed 100 kA/ $\mu$ s. The ultimate value which can be attained depends to a large extent upon the external circuit.
9. Measured with respect to cathode.
10. A lower rate of rise may be used, but this may result in the anode delay time, delay time drift and jitter exceeding the limits quoted.
11. If grid 1 is pulsed, the last 0.25  $\mu$ s of the top of the grid 1 pulse must overlap the corresponding first 0.25  $\mu$ s of the top of the delayed grid 2 pulse.
12. Negative bias may be needed depending on the configuration of the Grid 1, Grid 2 and Grid 3. See Trigger Grid Connections below.
13. In a screen grid configuration the CX1836/CX1836X must be triggered with a current pulse which is considerably higher than that required in a normal configuration.
14. The optimum grid 1 pulse current is the maximum value which can be applied without causing the tube to trigger before the grid 2 pulse is applied. This value is variable depending on gas pressure, maximum forward anode voltage, grid 2 negative bias voltage, peak current and repetition rate.
15. DC negative bias must not be applied to grid 1.
16. Measured between the second minute after the application of HT and 30 minutes later.
17. A time jitter of less than 1 ns can be obtained if the cathode heater voltage is supplied from a DC source, by adopting double pulsing, and by

applying a grid 2 pulse with a rate of rise of voltage (unloaded) in excess of 20 kV/ $\mu$ s.

18. Measured after a current pulse of 1000 A, with a grid 2 bias voltage of -100 V, a recovery impedance of 500  $\Omega$  and a 1.0 kV anode probe.

## HEALTH AND SAFETY HAZARDS

Teledyne e2v thyratrons are safe to handle and operate, provided that the relevant precautions stated herein are observed. Teledyne e2v does not accept responsibility for damage or injury resulting from the use of electronic devices it produces. Equipment manufacturers and users must ensure that adequate precautions are taken. Appropriate warning labels and notices must be provided on equipment incorporating Teledyne e2v devices and in operating manuals.



### High Voltage

Equipment must be designed so that personnel cannot come into contact with high voltage circuits. All high voltage circuits and terminals must be enclosed and fail-safe interlock switches must be fitted to disconnect the primary power supply and discharge all high voltage capacitors and other stored charges before allowing access. Interlock switches must not be bypassed to allow operation with access door open.



### X-Ray Radiation

All high voltage devices produce X-rays during operation and may require shielding. The X-ray radiation from hydrogen thyratrons is usually reduced to a safe level by enclosing the equipment or shielding the thyatron with at least 1.6 mm (1/16 inch) thick steel panels.

Users and equipment manufacturers must check the radiation level under their maximum operating conditions.

# TRIGGER GRID CONNECTIONS

## Modulator Service with two trigger pulses and negative bias

Recommended for maximum cathode utilisation and therefore maximum life.

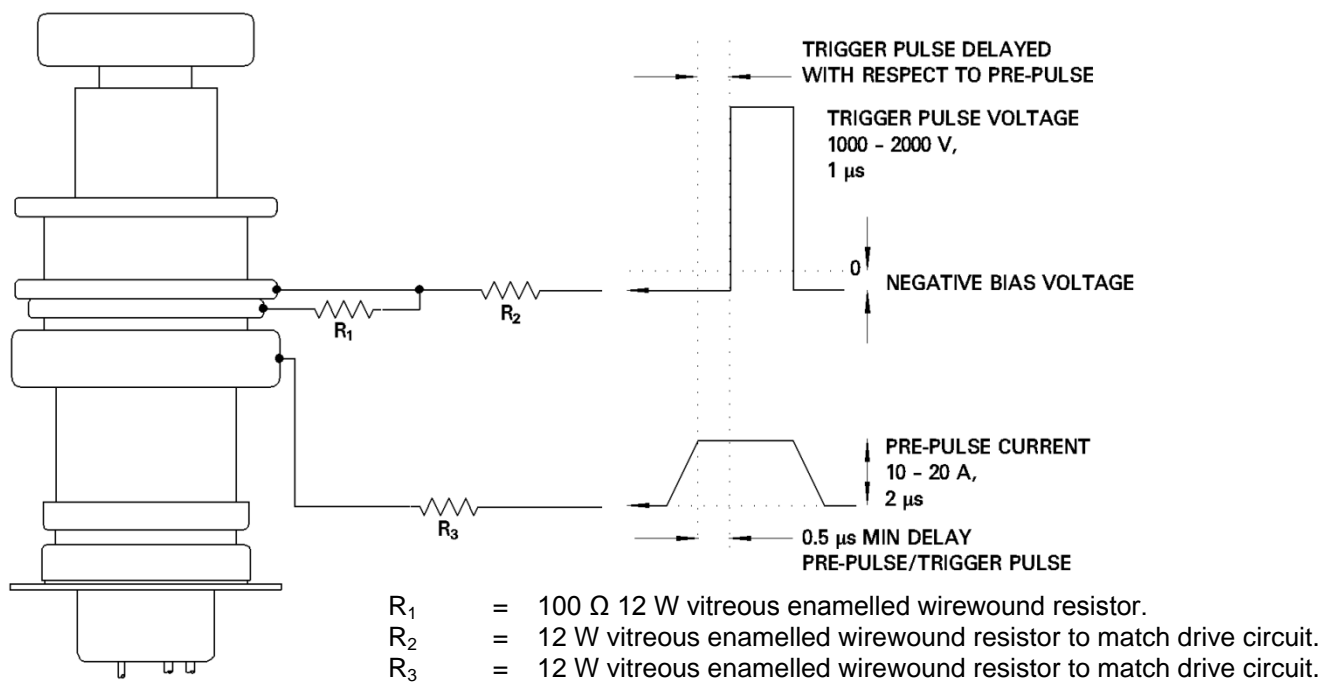

## Command Charge Service with Grid 3 as screen grid

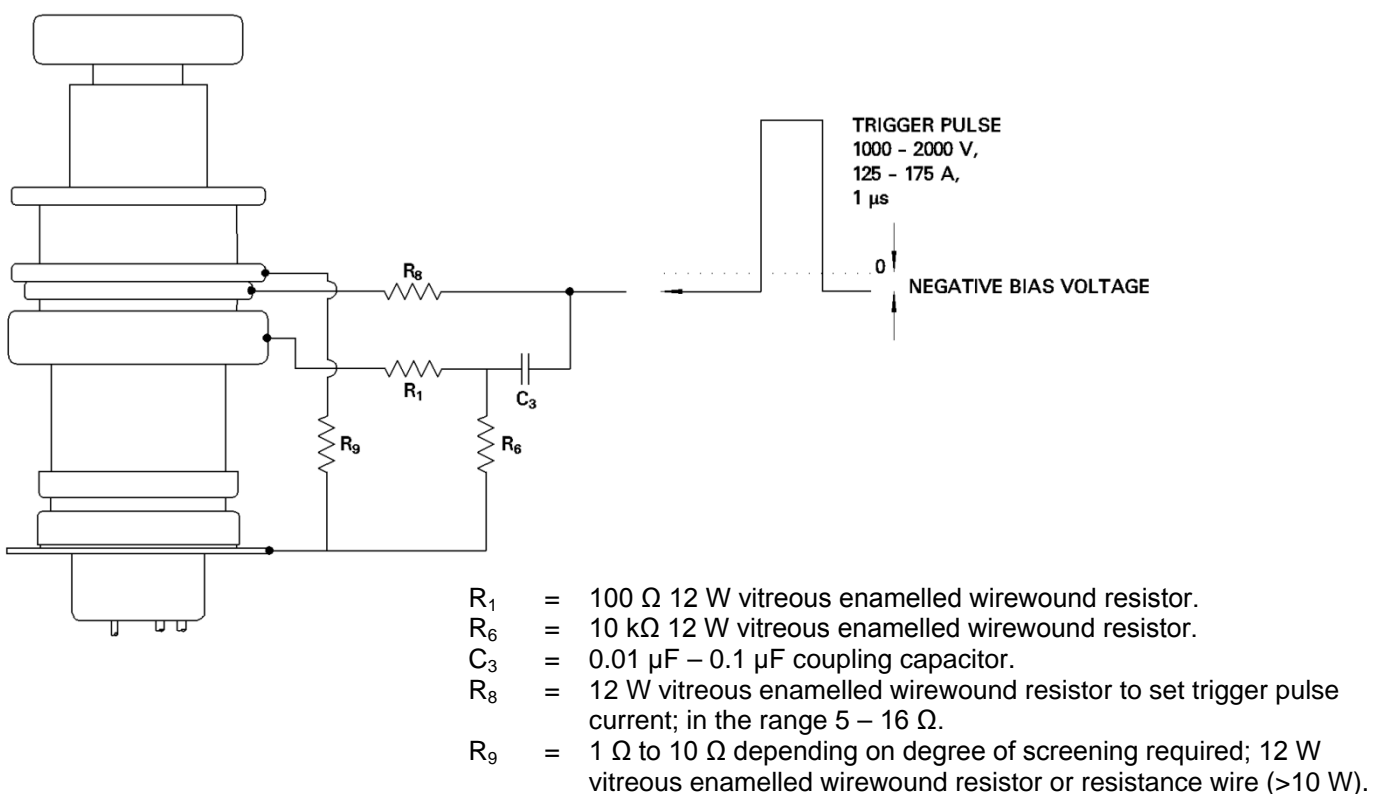

# SCHEMATIC

Gradient grid and heater connections

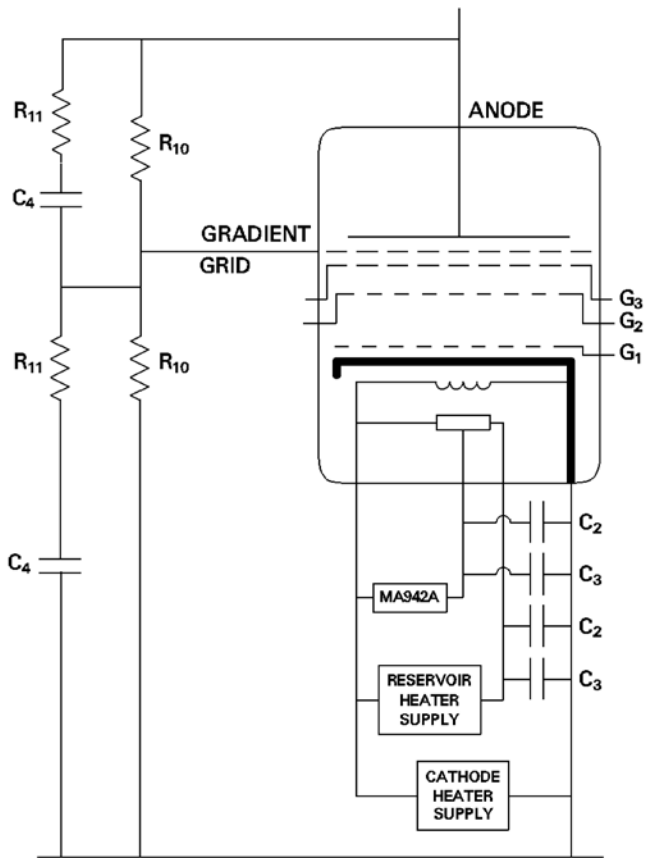

### Recommended Values

- $R_{10}$  = 10 to 25 M $\Omega$  high voltage resistors with a power rating consistent with the forward anode voltage.
- $R_{11}$  = 470  $\Omega$  - 1 k $\Omega$  12 W vitreous enamelled wirewound resistors.
- $C_4$  = 500 – 1,000 pF capacitors with a voltage rating equal to the peak forward voltage. These capacitors (and  $R_{11}$ ) may be needed to divide the voltage correctly across each gap when charging times are less than 5 ms approx.



# OUTLINE of CX1836X

(All dimensions without limits are nominal)

CX1836 outline is identical, except that it has no gas pressure control lead (black).

ANODE CONNECTION FITTED WITH 5 SCREWS 1/4-20 UNC, 1 IN CENTRE, 4 EQUISPACED ON D PCD

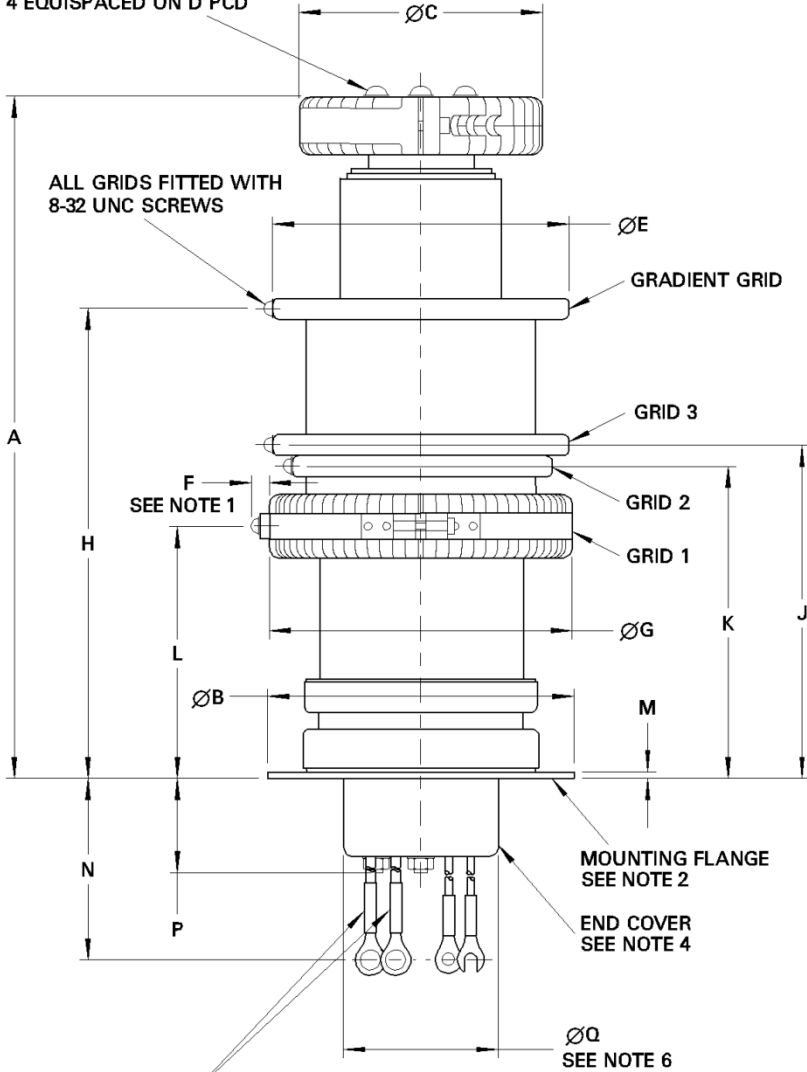

HEATER/RESERVOIR LEADS (YELLOW) TAGS TO SUIT ØR, SEE NOTE 3

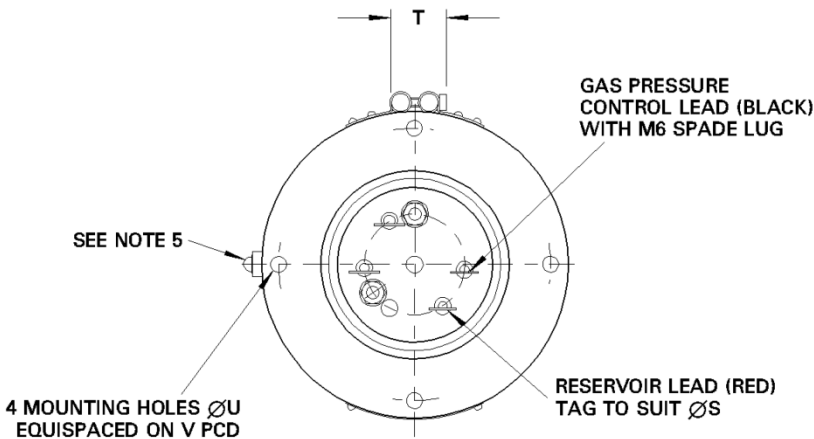

Ref	Millimetres	Inches
A	330.0 ± 6.0	12.992 ± 0.236
B	152.40 ± 0.25	6.000 ± 0.010
C	114.3 ± 3.0	4.500 ± 0.118
D	44.0	1.732
E	150.0 ± 3.0	5.906 ± 0.118
F	15.0 max	0.591 max
G	152.4 ± 3.0	6.000 ± 0.118
H	226.0 ± 6.0	8.898 ± 0.236
J	162.0 ± 6.0	6.378 ± 0.236
K	152.0 ± 6.0	5.984 ± 0.236
L	122.0 ± 6.0	4.803 ± 0.236
M	3.15 ± 0.25	0.124 ± 0.010
N	343.00 ± 6.35	13.504 ± 0.250
P	60.0 max	2.362 max
Q	78.0 max	3.071 max
R	9.5	0.374
S	6.0	0.236
T	36.0 max	1.417 max
U	8.0	0.315
V	135.7	5.343

Inch dimensions have been derived from millimetres

### Outline Notes

1. This dimension also applies to the clamping screws and lugs.
2. The mounting flange is the connection for the cathode and cathode heater return.
3. These two leads must be connected to the same terminal of the heater transformer.
4. The end cover is at heater potential and must not be grounded.
5. The terminal screws are in line with the hole in the mounting flange to within ±6.35 mm (0.250 inches).
6. The recommended mounting hole is 93.5 mm (3.861 inches) diameter.

# MA942A RESISTOR BOX

'X' type thyratrons have an additional lead on the base which enables the user to adjust the gas pressure inside the tube to a greater degree than is possible by changing the reservoir voltage. This allows the gas pressure to be optimised for a particular set of operating conditions, reducing the power dissipation in the thyatron to a minimum and maximising its switching speed. The maximum gas pressure allowable is dependent on the voltage hold off required; the higher the gas pressure, the more likely the thyatron is to break down spontaneously. Optimisation is achieved by increasing the gas pressure until the thyatron will no longer reliably hold off the required anode voltage, and then reducing it again only until the tube will operate reliably without spontaneous anode voltage breakdowns.

The gas pressure of Teledyne e2v metal envelope thyratrons is normally set during manufacture to allow reliable operation at the maximum rated anode voltage, by resistors inside the base cap of the tube. In 'X' type tubes, these resistors are omitted and replaced by two parallel variable resistors mounted in the MA942A resistor box which is connected to the thyatron as shown in the schematic diagram. Increasing the value of this parallel combination will increase the pressure in the thyatron.

'X' type thyratrons are supplied with a recommended minimum combination of values. Do not use a lower combined value of resistors as this would result in the tube being operated with an unacceptably low gas pressure and may lead to tube damage and reduced tube life.

Ten resistor values can be selected by each rotary switch (3.3 Ω, 4.7 Ω, 6.8 Ω, 8.2 Ω, 10 Ω, 15 Ω, 18 Ω, 22 Ω, 33 Ω, O/C), giving the range of possible values shown in the table.

Paralleled Value (Ω)	Control Box Settings (Ω)		Paralleled Value (Ω)	Control Box Settings (Ω)	
1.65	3.3	3.3	5.19	6.8	22.0
1.94	3.3	4.7	5.30	8.2	15.0
2.22	3.3	6.8	5.63	8.2	18.0
2.35	4.7	4.7	5.64	6.8	33.0
2.35	3.3	8.2	5.97	8.2	22.0
2.48	3.3	10.0	6.00	10.0	15.0
2.70	3.3	15.0	6.43	10.0	18.0
2.78	4.7	6.8	6.57	8.2	33.0
2.79	3.3	18.0	see note	6.8	O/C
2.87	3.3	22.0	6.87	10.0	22.0
2.99	4.7	8.2	7.50	15.0	15.0
3.00	3.3	33.0	7.67	10.0	33.0
3.20	4.7	10.0	8.18	15.0	18.0
see note	3.3	O/C	see note	8.2	O/C
3.40	6.8	6.8	8.92	15.0	22.0
3.58	4.7	15.0	9.00	18.0	18.0
3.72	6.8	8.2	9.00	18.0	22.0
3.73	4.7	18.0	see note	10.0	O/C
3.87	4.7	22.0	10.31	15.0	33.0
4.05	6.8	10.0	11.0	22.0	22.0
4.10	8.2	8.2	11.65	18.0	33.0
4.11	4.7	33.0	13.2	22.0	33.0
4.51	8.2	10.0	15.0	15.0	O/C
4.68	6.8	15.0	16.5	33.0	33.0
see note	4.7	O/C	18.0	18.0	O/C
4.94	6.8	18.0	22.0	22.0	O/C
5.00	10.0	10.0	33.0	33.0	O/C
			O/C	O/C	O/C

**Note:** Do not set parallel resistors to these values, as this may cause the power rating of the resistor to be exceeded.

## OUTLINE

(All dimensions without limits are nominal)

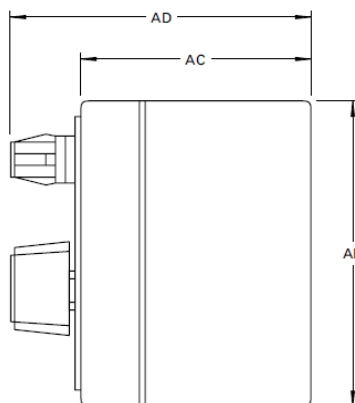
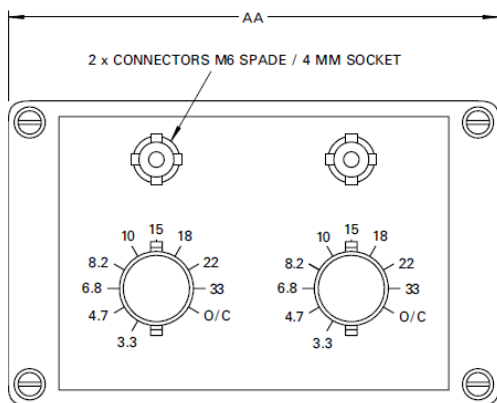

Ref	Millimetres	Inches
AA	125.0	4.921
AB	80.0	3.150
AC	57.0	2.244
AD	85.0 max	3.346 max

Inch dimensions have been derived from millimetres