

E2V Technologies

CX1725A, CX1725AX Air Cooled, Hollow Anode, Two-Gap Metal/Ceramic Thyratrons

The data to be read in conjunction with the Hydrogen Thyatron Preamble.

ABRIDGED DATA

Hollow anode, deuterium-filled two-gap thyratrons with metal/ceramic envelope, featuring high peak current, high rate of rise of current, low jitter and >50% voltage/current reversal. They have been developed specifically for use in low inductance circuits associated with excimer lasers.

The patented hollow anode structure enables the tube to cope with inverse voltage and current without consequent reduction in its high voltage hold off capability due to electrode damage.

To optimise the switching performance, these thyratrons have been designed to be primed by a high current pre-pulse into grid 1. The use of a DC current to prime grid 1 may cause high values of time jitter.

A reservoir normally operated from a separate heater supply is incorporated. The reservoir heater voltage can be adjusted to a value consistent with anode voltage hold-off in order to achieve the fastest rate of rise of current possible from the tube in the circuit.

The CX1725AX, which must be used in conjunction with E2V Technologies resistor box MA942A, permits a larger variation in internal deuterium pressure than the CX1725A. Resistor box settings and/or reservoir heater voltage can be adjusted within the specified limits to obtain the maximum thyatron gas pressure consistent with the required voltage hold-off.

| | | |
|--------------------------------------|------|-------------|
| Peak forward anode voltage | 50 | kV max |
| Peak forward anode current | 15 | kA max |
| Peak reverse anode current | 10 | kA max |
| Average anode current | 5.0 | A max |
| Rate of rise of current | >300 | kA/ μ s |
| Jitter | 1.0 | ns |
| Pulse repetition rate | 2000 | pps max |

GENERAL DATA

Electrical

| | |
|--|---------------------------------------|
| Cathode | barium aluminate impregnated tungsten |
| Cathode heater voltage (see note 1) | 6.3 \pm 0.3 V |
| Cathode heater current | 37.5 A |
| Reservoir heater voltage (see notes 1 and 2) | 6.3 \pm 0.7 V |
| Reservoir heater current | 7.0 A |
| Tube heating time (minimum) | 10.0 min |

Mechanical

| | |
|--|---------------------------|
| Seated height | 240 mm (9.449 inches) max |
| Clearance required below mounting flange | 80 mm (3.150 inches) min |
| Overall diameter (excluding connections) | 122 mm (4.803 inches) max |
| Net weight | 3.6 kg (8 pounds) approx |
| Mounting position | see note 3 |
| Tube connections | see outline |

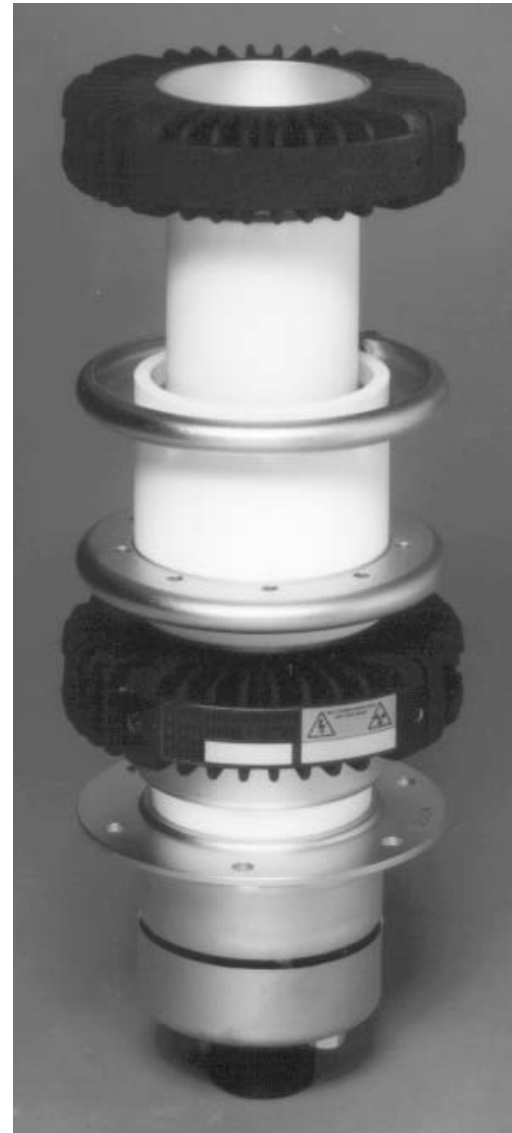

Cooling

The tube must be cooled by forced-air directed mainly onto the base and the metal/ceramic envelope should be maintained below the maximum rated temperature. A fan of output between 2.83 and 7.01 m³/min (100 and 250 ft³/min) (depending on the mechanical layout) will be necessary to keep the tube operating temperatures below the limits specified below. E2V Technologies cooling modules, types MA2235A and MA2235B, are suitable for the purpose.

In addition to 275 W of heater power, the tube dissipates from 100 watts per ampere average anode current, rising to 300 W/A or greater at the highest rate of rise and fall of anode current.

The cathode end of the tube must be cooled whenever heater voltages are applied.

| | |
|---|------------|
| Envelope temperature: | |
| anode, gradient grid, grid 1 and grid 2 | 200 °C max |
| cathode flange and end cover | 120 °C max |

PULSE MODULATOR SERVICE

MAXIMUM AND MINIMUM RATINGS

These ratings cannot necessarily be used simultaneously, and no individual rating must be exceeded.

| | Min | Max | |
|--|-------------------|-----|----|
| Anode | | | |
| Peak forward anode voltage (see note 4) | - | 50 | kV |
| Peak inverse anode voltage (see note 5) | - | 50 | kV |
| Peak forward anode current | - | 15 | kA |
| Average anode current | - | 5 | A |
| Rate of rise of anode current | see notes 6 and 7 | | |

Triggering

These thyratrons should be triggered with a pre-pulse on grid 1.

| | Min | Max | |
|---|------|------|-------|
| Grid 2 | | | |
| Unloaded grid 2 drive pulse voltage (see note 8) | 600 | 2000 | V |
| Grid 2 pulse duration | 0.5 | - | μs |
| Rate of rise of grid 2 pulse (see notes 7 and 9) | 10 | - | kV/μs |
| Grid 2 pulse delay (see note 10) | 0.5 | 3.0 | μs |
| Peak inverse grid 2 voltage | - | 450 | V |
| Loaded grid 2 bias voltage (see note 11) | -100 | -300 | V |
| Impedance of grid 2 drive circuit (see note 12) | 50 | 200 | Ω |

Grid 1 - Pulsed

| | | | |
|--|-------------|------|-------|
| Unloaded grid 1 drive pulse voltage | 600 | 2000 | V |
| Grid 1 pulse duration | 2.0 | - | μs |
| Rate of rise of grid 1 pulse | 1.0 | - | kV/μs |
| Peak inverse grid 1 voltage | - | 450 | V |
| Loaded grid 1 bias voltage | see note 13 | | |
| Peak grid 1 drive current (see note 14) | 10.0 | 25.0 | A |

Cathode

| | | |
|----------------|-----------|-----|
| Heater voltage | 6.3 ± 0.3 | V |
| Heating time | 10 | min |

Reservoir

| | | |
|----------------|--------------------|-----|
| Heater voltage | 6.3 + 0.7 - 0.3 | V |
| Heating time | 10 | min |

Environmental

| | | | |
|---------------------|---|-----|----|
| Ambient temperature | 0 | +40 | °C |
|---------------------|---|-----|----|

CHARACTERISTICS

| | Min | Typical | Max | |
|---|-----|---------|-----|----|
| Critical DC anode voltage for conduction | - | 0.5 | 2.0 | kV |
| Anode delay time | - | 200 | 250 | ns |
| Anode delay time drift (see note 15) | - | 15 | 25 | ns |
| Time jitter (see note 16) | - | 1.0 | 5.0 | ns |
| Recovery time (see note 17) | - | 20 | - | μs |
| Cathode heater current (at 6.3 V) | 30 | 37.5 | 45 | A |
| Reservoir heater current (at 6.3 V) | 6.0 | 7.0 | 8.0 | A |

NOTES

- It is recommended that the cathode heater and the reservoir heater are supplied from independent power supplies. **The common connection for these two supplies is the yellow sleeved lead, not the cathode flange.**

N.B. The tube will suffer irreversible damage if the cathode flange is connected as the common point.

The cathode heater supply must be connected between the cathode flange and the cathode heater lead (yellow sleeve), the reservoir heater supply must be connected between the cathode heater lead (yellow sleeve) and the reservoir heater lead (red sleeve), see Figs. 1 and 2. In order to meet the jitter specification, it may be necessary in some circumstances that the cathode heater be supplied from a DC source.

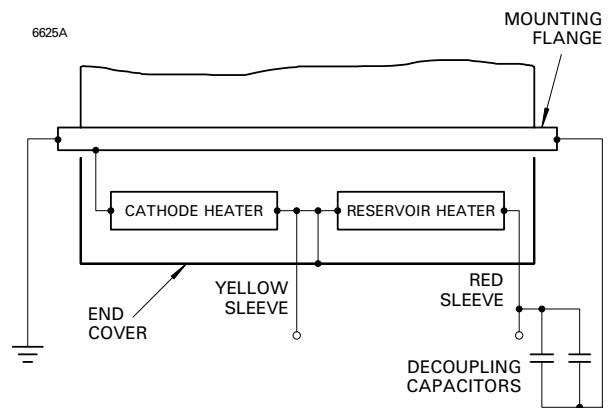

Fig. 1 CX1725A base connections

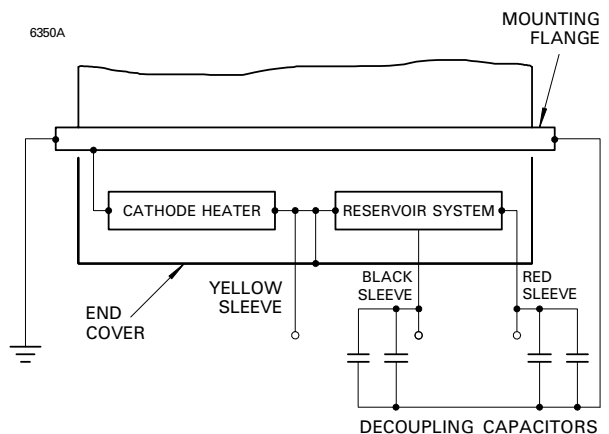

Fig. 2 CX1725AX base connections

Care should be taken to ensure that excessive voltages are not applied to the reservoir heater circuit from the cathode heater supply because of high impedance cathode heater connections. For example, in the worst case, an open circuit heater lead will impress almost double voltage on the reservoir heater, especially on switch-on, when the cathode heater impedance is minimal. This situation can be avoided by ensuring that the two supplies are in anti-phase. The reservoir heater circuit must be decoupled with suitable capacitors, for example, a 1 μF capacitor in parallel with a low inductance 1000 pF capacitor.

The heater supply systems should be connected directly between the cathode flange and the heater leads. This avoids the possibility of injecting voltages into the cathode and reservoir heaters. At high rates of rise of anode current, the cathode potential may rise significantly at the beginning of the pulse, depending on the cathode lead inductance, which must be minimised at all times.

If a single transformer is used to supply both the cathode heater and the reservoir heater, then the reservoir heater lead (red sleeve) must be connected to the mounting flange.

2. CX1725AX gas pressure may be altered using E2V Technologies resistor box type MA942A. The CX1725AX **must** be used in conjunction with the MA942A. The resistor box must be connected between the gas pressure control lead (black sleeve) and the cathode heater lead (yellow sleeve). Gas pressure may be increased by increasing the resistor box settings from their initial recommended values which accompany each delivered CX1725AX. The gas pressure may be increased to a value consistent with the required forward hold-off voltage. Additional variations in gas pressure can be achieved by altering the reservoir heater supply voltage within the specified range.
3. The tube must be fitted using its mounting flange, with flexible connections to all other electrodes. The preferred orientation is with the tube axis vertical and anode uppermost; mounting the tube with its axis horizontal is permissible. It is **not** recommended that the tube is mounted with its axis vertical and cathode uppermost.
4. The maximum permissible peak forward voltage for instantaneous starting is 40 kV and there must be no overshoot.
5. Due to the bidirectional switching capability of the tube, the presence of any reverse voltages following the forward current pulse will result in reverse current.
6. The ultimate value which can be attained depends to a large extent upon the external circuit. The rate of rise of current can be well in excess of 100 kA/ μs .
7. This rate of rise refers to that part of the leading edge of the pulse between 10% and 90% of the pulse amplitude.
8. Measured with respect to cathode.
9. A lower rate of rise may be used, but this may result in the anode delay time, delay time drift and jitter exceeding the limits quoted.
10. The last 0.25 μs of the top of the grid 1 pulse must overlap the corresponding first 0.25 μs of the top of the delayed grid 2 pulse.
11. Negative bias of 100 to 200 V must be applied to grid 2 to ensure anode voltage hold-off.
12. During both the drive pulse period and during recovery when the current flow is reversed.
13. DC negative bias voltages must not be applied to grid 1.
14. The optimum grid 1 pulse current is the maximum value which can be applied without causing the tube to switch before the grid 2 pulse is applied. This value is variable depending on gas pressure, maximum forward anode voltage, grid 2 negative bias voltage, peak current and repetition rate.
15. Measured between the second minute after the application of HT and 30 minutes later.
16. A time jitter of less than 1 ns can be obtained if the cathode heater voltage is supplied from a DC source, by adopting double-pulsing, and by applying a grid 2 pulse with a rate of rise of voltage (unloaded) in excess of 20 kV/ μs .
17. The amount of time available for thyatron recovery must be maximised by circuit design, and reliable operation may necessitate the use of command charging techniques. The amount of time required for recovery is affected by gas pressure, peak current, pulse duration and load mismatch which keeps the thyatron in a conducting state.

HEALTH AND SAFETY HAZARDS

E2V Technologies hydrogen thyratrons are safe to handle and operate, provided that the relevant precautions stated herein are observed. E2V Technologies does not accept responsibility for damage or injury resulting from the use of electronic devices it produces. Equipment manufacturers and users must ensure that adequate precautions are taken. Appropriate warning labels and notices must be provided on equipments incorporating E2V Technologies devices and in operating manuals.



High Voltage

Equipment must be designed so that personnel cannot come into contact with high voltage circuits. All high voltage circuits and terminals must be enclosed and fail-safe interlock switches must be fitted to disconnect the primary power supply and discharge all high voltage capacitors and other stored charges before allowing access. Interlock switches must not be bypassed to allow operation with access doors open.



X-Ray Radiation

All high voltage devices produce X-rays during operation and may require shielding. The X-ray radiation from hydrogen thyratrons is usually reduced to a safe level by enclosing the equipment or shielding the thyatron with at least 1.6 mm ($1/16$ inch) thick steel panels.

Users and equipment manufacturers must check the radiation level under their maximum operating conditions.

OUTLINE OF CX1725A

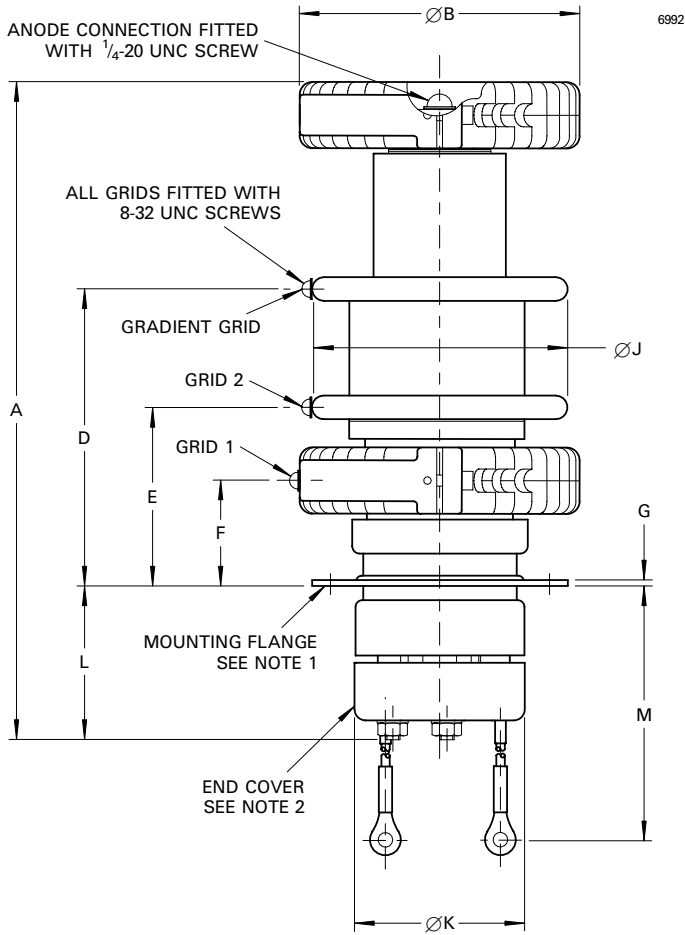

Outline Dimensions for CX1725A and CX1725AX

| Ref | Millimetres | Inches |
|-----|-------------|-----------|
| A | 288.0 | 11.338 |
| B | 122.0 max | 4.803 max |
| D | 131.0 | 5.157 |
| E | 80.0 | 3.150 |
| F | 46.0 | 1.811 |
| G | 2.50 | 0.100 |
| H | 111.13 | 4.375 |
| J | 111.13 | 4.375 |
| K | 75.0 max | 2.953 max |
| L | 70.0 max | 2.756 max |
| M | 381.0 | 15.000 |
| N | 95.25 | 3.750 |
| P | 6.50 | 0.256 |

Inch dimensions have been derived from millimetres.

Outline Notes

1. The mounting flange is the connection for the cathode and cathode heater return.
2. The end cover is at heater potential and must not be grounded.

Detail of Mounting Flange

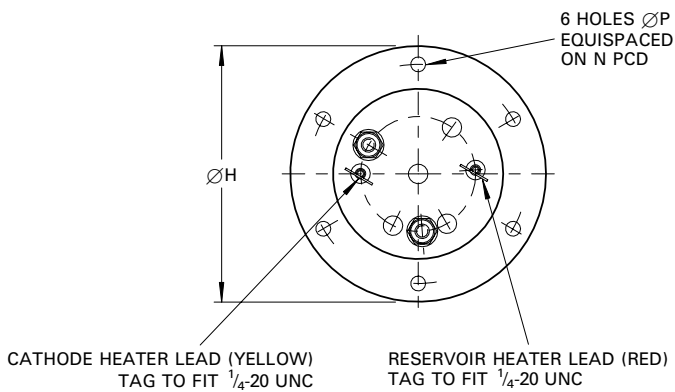

OUTLINE OF CX1725AX

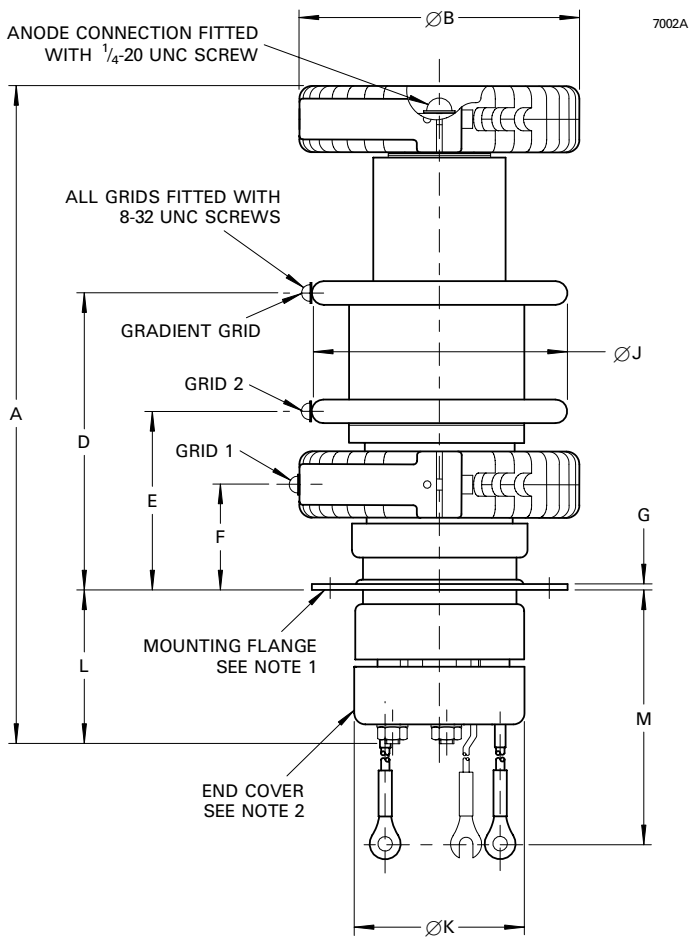

Detail of Mounting Flange

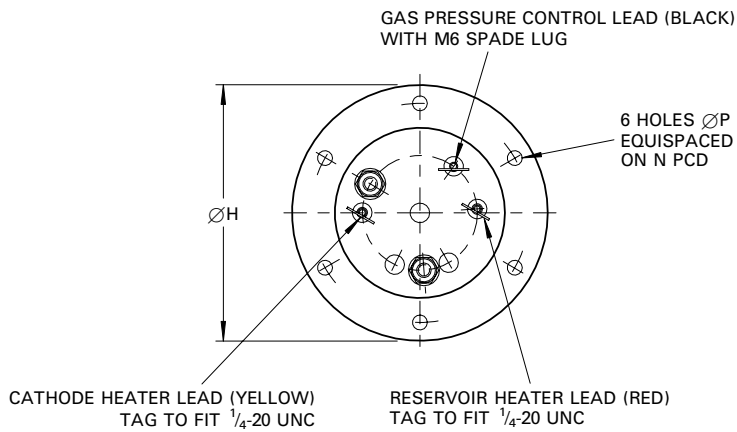

CX1725A SCHEMATIC DIAGRAM

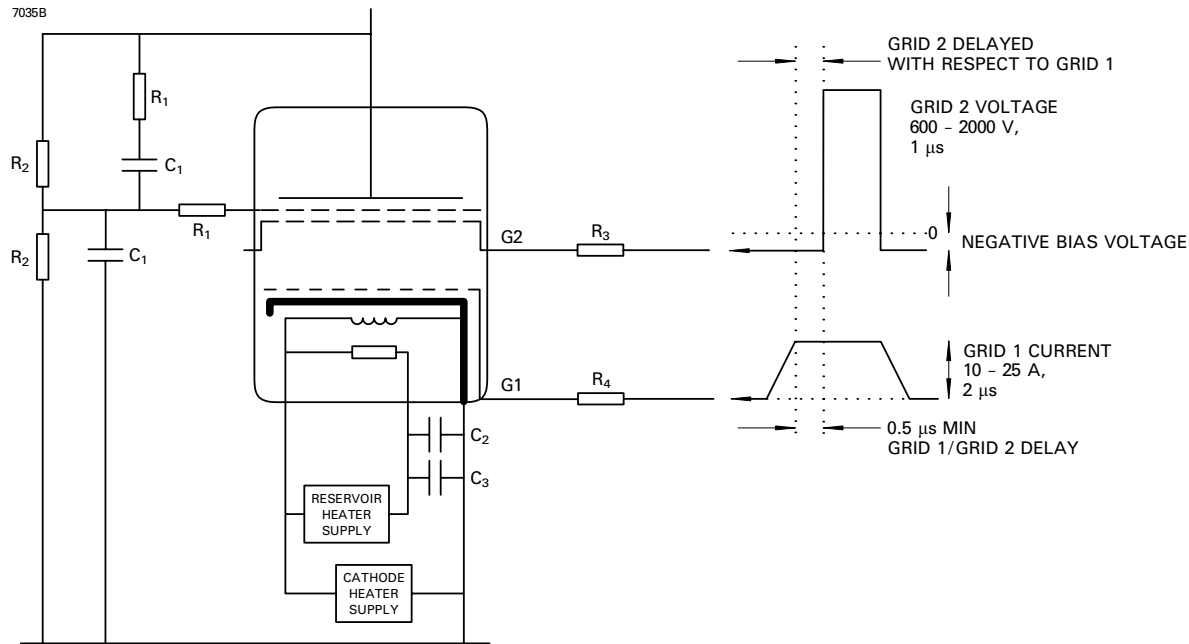

CX1725AX SCHEMATIC DIAGRAM

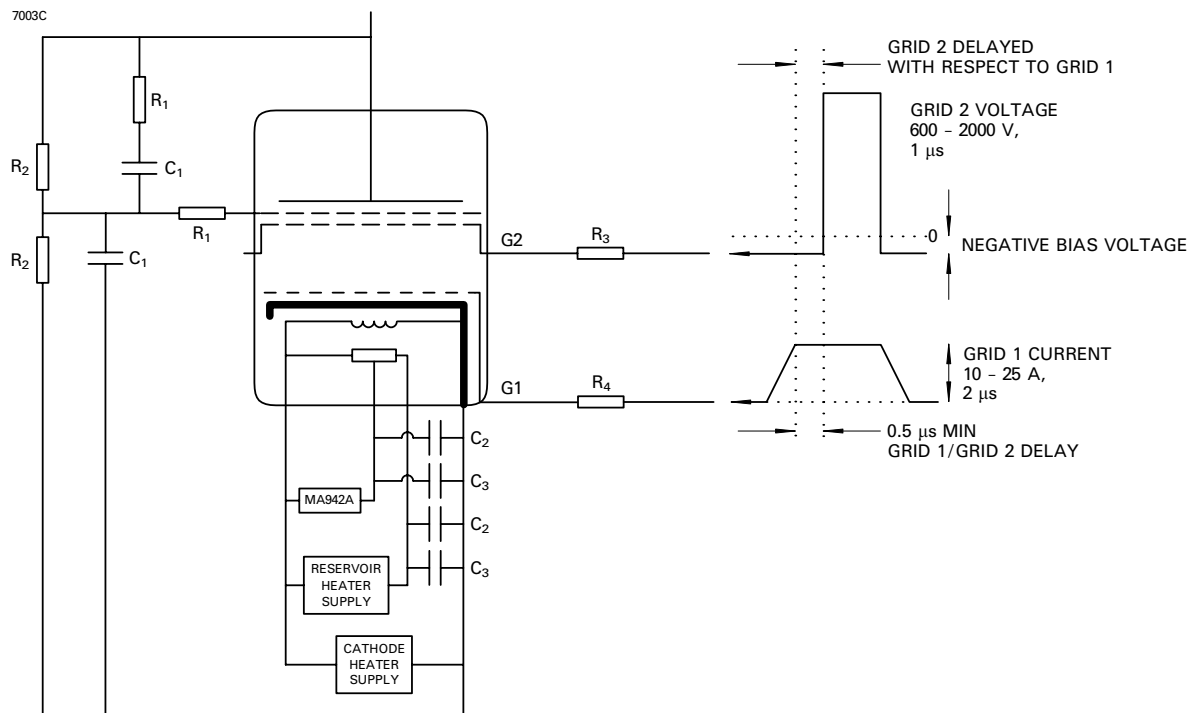

Recommended Values (both diagrams)

- R₁ = 470 Ω 2.5 W vitreous enamelled wirewound resistors.
- R₂ = 5 to 20 M Ω high voltage resistors with a power rating consistent with forward anode voltage.
- R₃ = Grid 2 series resistor. 12 W vitreous enamelled wirewound is recommended, of an impedance to match the grid 2 drive pulse circuit.
- R₄ = Grid 1 series resistor. 12 W vitreous enamelled wirewound is recommended, of a total impedance to match the grid 1 drive pulse circuit.

- C₁ = 500 pF capacitors with a voltage rating equal to the peak forward voltage (C₁ is needed to share the anode voltage equally between the high voltage gaps on fast charging rates. When the charging time is greater than approx. 5 ms, C₁ may be omitted).
 - C₂, C₃ : Reservoir protection capacitors with a voltage rating \geq 500 V;
 - C₂ = 1000 pF low inductance (e.g. ceramic),
 - C₃ = 1 μ F (e.g. polycarbonate or polypropylene).
- Components R₃, R₄, C₂ and C₃ should be mounted as close to the tube as possible.

MA942A RESISTOR BOX

'X' type thyratrons have an additional lead on the base which enables the user to adjust the gas pressure inside the tube to a greater degree than is possible by changing the reservoir voltage. This allows the gas pressure to be optimised for a particular set of operating conditions, reducing the power dissipation in the thyratron to a minimum and maximising its switching speed. The maximum gas pressure allowable is dependent on the voltage hold off required; the higher the gas pressure, the more likely the thyratron is to break down spontaneously. Optimisation is achieved by increasing the gas pressure until the thyratron will no longer reliably hold off the required anode voltage, and then reducing it again only until the tube will operate reliably without spontaneous anode voltage breakdowns.

The gas pressure of E2V Technologies metal envelope thyratrons is normally set during manufacture to allow reliable operation at the maximum rated anode voltage, by resistors inside the base cap of the tube. In 'X' type tubes, these resistors are omitted and replaced by two parallel variable resistors mounted in the MA942A resistor box which is connected to the thyratron as shown in the schematic diagram. Increasing the value of this parallel combination will increase the pressure in the thyratron.

'X' type thyratrons are supplied with a recommended minimum combination of values. Do not use a lower combined value of resistors as this would result in the tube being operated with an unacceptably low gas pressure and may lead to tube damage and reduced tube life.

Ten resistor values can be selected by each rotary switch (3.3 Ω, 4.7 Ω, 6.8 Ω, 8.2 Ω, 10 Ω, 15 Ω, 18 Ω, 22 Ω, 33 Ω, O/C), giving the range of possible values shown in the table.

OUTLINE

(All dimensions without limits are nominal)

| Ref | Millimetres | Inches |
|-----|-------------|-----------|
| AA | 125.0 | 4.921 |
| AB | 80.0 | 3.150 |
| AC | 57.0 | 2.244 |
| AD | 85.0 max | 3.346 max |

Inch dimensions have been derived from millimetres.

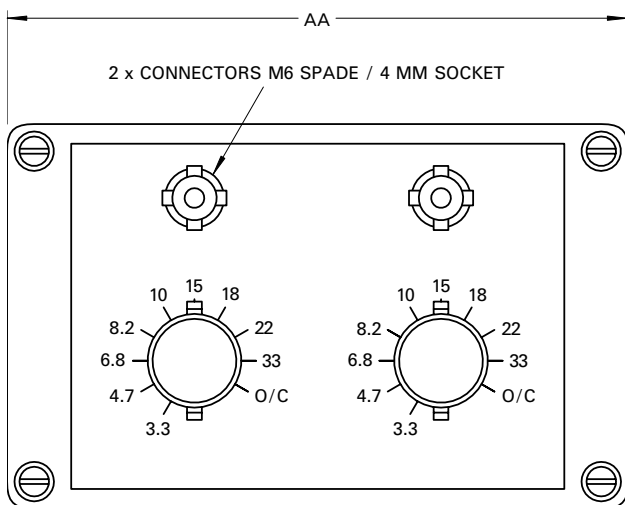

| Paralleled Value (Ω) | Control Box Settings (Ω) | Paralleled Value (Ω) | Control Box Settings (Ω) | | |
|----------------------|--------------------------|----------------------|--------------------------|------|------|
| 1.65 | 3.3 | 3.3 | 5.19 | 6.8 | 22.0 |
| 1.94 | 3.3 | 4.7 | 5.30 | 8.2 | 15.0 |
| 2.22 | 3.3 | 6.8 | 5.63 | 8.2 | 18.0 |
| 2.35 | 4.7 | 4.7 | 5.64 | 6.8 | 33.0 |
| 2.35 | 3.3 | 8.2 | 5.97 | 8.2 | 22.0 |
| 2.48 | 3.3 | 10.0 | 6.00 | 10.0 | 15.0 |
| 2.70 | 3.3 | 15.0 | 6.43 | 10.0 | 18.0 |
| 2.78 | 4.7 | 6.8 | 6.57 | 8.2 | 33.0 |
| 2.79 | 3.3 | 18.0 | see note | 6.8 | O/C |
| 2.87 | 3.3 | 22.0 | 6.87 | 10.0 | 22.0 |
| 2.99 | 4.7 | 8.2 | 7.50 | 15.0 | 15.0 |
| 3.00 | 3.3 | 33.0 | 7.67 | 10.0 | 33.0 |
| 3.20 | 4.7 | 10.0 | 8.18 | 15.0 | 18.0 |
| see note | 3.3 | O/C | see note | 8.2 | O/C |
| 3.40 | 6.8 | 6.8 | 8.92 | 15.0 | 22.0 |
| 3.58 | 4.7 | 15.0 | 9.00 | 18.0 | 18.0 |
| 3.72 | 6.8 | 8.2 | 9.90 | 18.0 | 22.0 |
| 3.73 | 4.7 | 18.0 | see note | 10.0 | O/C |
| 3.87 | 4.7 | 22.0 | 10.31 | 15.0 | 33.0 |
| 4.05 | 6.8 | 10.0 | 11.0 | 22.0 | 22.0 |
| 4.10 | 8.2 | 8.2 | 11.65 | 18.0 | 33.0 |
| 4.11 | 4.7 | 33.0 | 13.2 | 22.0 | 33.0 |
| 4.51 | 8.2 | 10.0 | 15.0 | 15.0 | O/C |
| 4.68 | 6.8 | 15.0 | 16.5 | 33.0 | 33.0 |
| see note | 4.7 | O/C | 18.0 | 18.0 | O/C |
| 4.94 | 6.8 | 18.0 | 22.0 | 22.0 | O/C |
| 5.00 | 10.0 | 10.0 | 33.0 | 33.0 | O/C |
| | | | O/C | O/C | O/C |

Note Do not set parallel resistors to these values, as this may cause the power rating of the resistor to be exceeded.

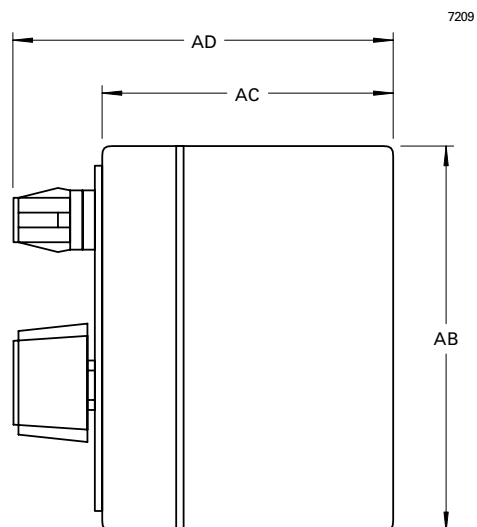

MA2235A/MA2235B COOLING MODULES

The MA2235A/MA2235B cooling modules are designed to air-cool the E2V Technologies range of medium size metal envelope thyratrons. The MA2235A is fitted with a 110 V 40 W fan and the MA2235B with a 220 V 40 W fan.

The cooling system consists of a thyatron mounting flange assembly, grid connectors, upper and lower plastic air ducts, and a fan. To prevent the thyatron overheating, a fan stop detection device (see Fig. 3) is fitted to the finger guard below the fan. This is a heated thermal reed switch consuming approximately 7 W at the same mains power supply voltage as the cooling fan. The reed switch contacts open shortly after fan failure and must be connected to the system so that all power (high voltage and thyatron heater supplies) is removed from the thyatron in the event of air flow reduction or stoppage.

Nominal mains power supply voltage:

| | | |
|-------------------------------|---------|------|
| MA2235A | 110 | V ac |
| MA2235B | 220 | V ac |
| Ambient temperature | 0 to 60 | °C |
| Weight | 3.6 | kg |

Maximum electrical contact ratings for reed switch (terminals 1 and 2):

| | AC | DC | |
|-------------------|-----|-----|---|
| Voltage | 140 | 200 | V |
| Current | 0.5 | 0.5 | A |
| Power | 35 | 10 | W |

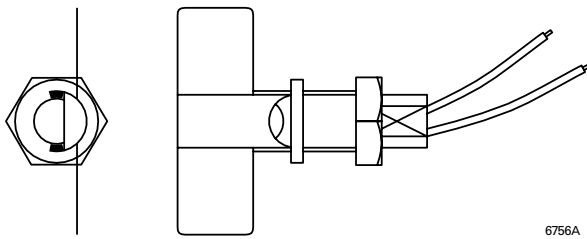
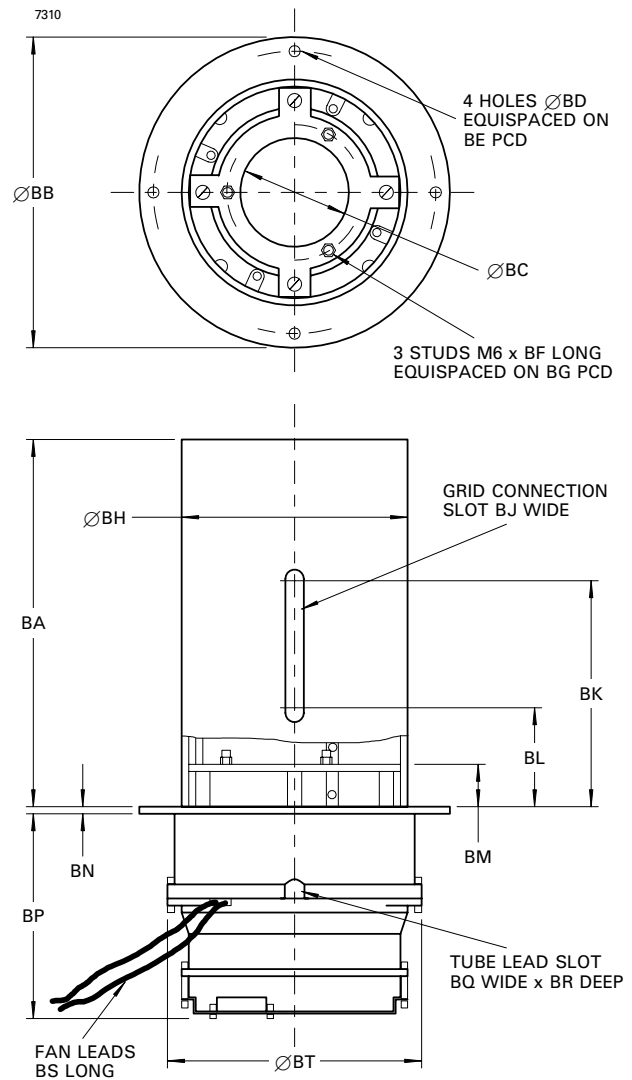

Fig. 3. Fan stop detection device

OUTLINE

(All dimensions without limits are nominal)



| Ref | Millimetres | Inches |
|-----|-------------|------------|
| BA | 260.0 | 10.236 |
| BB | 220.0 | 8.661 |
| BC | 76.2 | 3.000 |
| BD | 7.0 | 0.276 |
| BE | 200.0 | 7.874 |
| BF | 13.0 | 0.512 |
| BG | 95.25 | 3.750 |
| BH | 160.0 | 6.299 |
| BJ | 12.7 | 0.500 |
| BK | 164.0 | 64.57 |
| BL | 70.0 | 2.756 |
| BM | 28.6 | 1.126 |
| BN | 4.75 | 0.187 |
| BP | 145.0 max | 5.709 max |
| BQ | 16.0 | 0.630 |
| BR | 16.0 | 0.630 |
| BS | 254.0 min | 10.000 min |
| BT | 181.0 max | 7.126 max |

Inch dimensions have been derived from millimetres.

Whilst E2V Technologies has taken care to ensure the accuracy of the information contained herein it accepts no responsibility for the consequences of any use thereof and also reserves the right to change the specification of goods without notice. E2V Technologies accepts no liability beyond that set out in its standard conditions of sale in respect of infringement of third party patents arising from the use of tubes or other devices in accordance with information contained herein.