

Zementierte Drahtwiderstände

Cement-coated wire wound resistors / Résistances bobinées cimentées

Zementierte Drahtwiderstände mit gepunktetem Schellenanschluss (mit verstellbarer Abgreifschelle)
Cemented wire wound resistors with spotwelded radial tabs (with adjustable lugs)
Résistances bobinées cimentées avec bague apparente, soudées par points (à collier ajustable)

ZDSA
ZDRS

Keramikprofile:

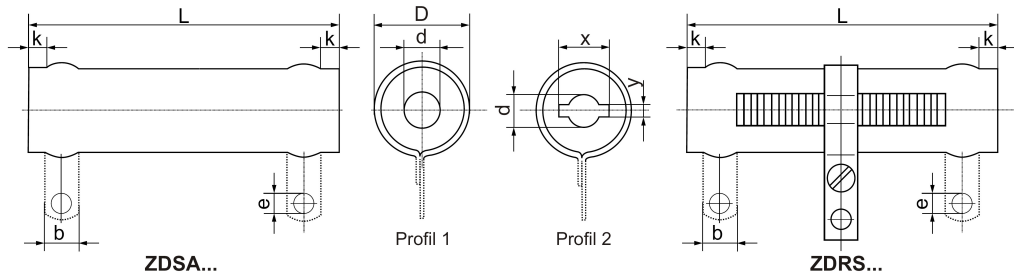

Widerstände mit Kreuzprofil auf Anfrage
Resistors with cross-type profile on request
Résistances à profil en croix, sur demande

Lieferbare Schellenanschlüsse s. Tabelle
Deliverable tabs see schedule
Pattes livrables voir tableau

Bauform Style Modèle	ZDSA 9 x 45 ZDRS 9 x 45	ZDSA 13 x 55 ZDRS 13 x 55	ZDSA 16 x 63 ZDRS 16 x 63	
Baugröße nach DIN 44192 Style to DIN 44192 Modèle selon DIN 44192	9 x 45	13 x 55	16 x 63	
Widerstandsbereich Resistance range Plage de valeurs	R62 -	R62 -	R62 -	
Widerstandswert-Toleranzen Resistance tolerances Tolérances sur la résistance	K ($\pm 10\%$), J ($\pm 5\%$)			
Nennlast Power rating Puissance nominale	6 W	12 W	20 W	
Belastbarkeit bei Dissipation at Puissance à	$\vartheta_o = 200\text{ °C}$ $\vartheta_o = 300\text{ °C}$ $\vartheta_o = 350\text{ °C}$	3,7 W 7,3 W 9,5 W	6,2 W 12,0 W 16,0 W	
Belastbarkeit bei Dissipation at Puissance à	$\vartheta_o = 200\text{ °C}$ $\vartheta_o = 300\text{ °C}$ $\vartheta_o = 350\text{ °C}$	2,9 W 6,0 W 8,1 W	4,8 W 10,0 W 14,0 W	
Grenzspannung Limiting voltage Tension limite	250 V	300 V	400 V	
Lieferbare Profile Profiles available Profils livrables	1	1	1 2	
Abmessungen in mm Dimensions in mm Dimensions en mm	D L d x y	11 45 $\pm 1,5$ 4,5 - -	13 55 $\pm 1,5$ 5,5 - -	16 63 ± 2 8,0 - -
Lieferbare Schellenanschlüsse Deliverable tabs Pattes livrables	P (E)	P (E)	P (E)	
Abmessungen in mm Dimensions in mm Dimensions en mm	b c e ϕ fmax gmax k m n	5,0 0,5 3,2 14,0 - - 2,5 - 3,0 12,0	5,0 0,5 3,2 20,0 - - - 5,0 - 3,0 12,0	6,0 0,5 3,2 17,0 - - 5,0 - 3,0 12,0

Anmerkung : ϑ_u = Umgebungstemperatur
Notes: Ambient temperature
Nota: Température ambiante

ϑ_o = Oberflächentemperatur
Surface temperature
Température surface

Bestellbeispiel:

Order designation: 500 Stück ZDSA-P1 24 x 165 10R J
Code de commande



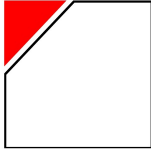

Zementierte Drahtwiderstände

Cement-coated wire wound resistors / Résistances bobinées cimentées

Zementierte Drahtwiderstände mit gepunktetem Schellenanschluss (mit verstellbarer Abgreifschelle)

Cemented wire wound resistors with spotwelded radial tabs (with adjustable lugs)

Résistances bobinées cimentées avec bague apparente, soudées par points (à collier ajustable)

ZDSA
ZDRS

Abgreifschelle - adjustable lug - collier ajustable

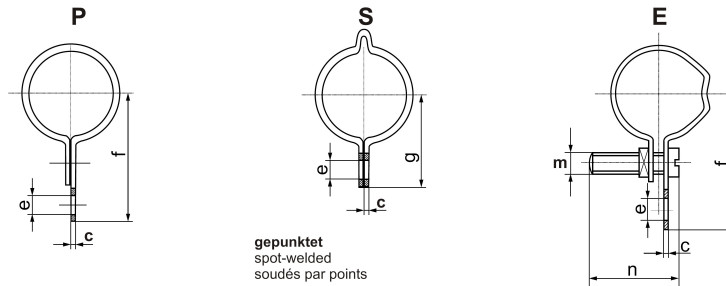

Schellen P unterzementiert und lötfähig
Tabs P with cement underlay and solderable
Colliers P sous ciment et soudable

Bauform Style Modèle	ZDSA 16 x 100 ZDRS 16 x 100		ZDSA 24 x 100 ZDRS 24 x 100		ZDSA 24 x 165 ZDRS 24 x 165		ZDSA 24 x 265 ZDRS 24 x 265		ZDSA 36 x 330 ZDRS 36 x 330			
Baugröße nach DIN 44192 Style to DIN 44192 Modèle selon DIN 44192	16 x 100		24 x 100		24 x 165		24 x 265		36 x 330			
Widerstandswertbereich Resistance range Plage de valeurs	1R1 -		1R3 -		2R7 -		4R7 -		8R2 -			
	82K		91K		200K		360K		620K			
Widerstandswert-Toleranzen Resistance tolerances Tolérances sur la résistance	K ($\pm 10\%$), J ($\pm 5\%$)											
Nennlast Power rating Puissance nominale	35 W		50 W		100 W		150 W		300 W			
Belastbarkeit bei Dissipation at $\vartheta_{Lu}=40^\circ\text{C}$ Puissance à $\vartheta_{Lu}=350^\circ\text{C}$	$\vartheta_{Lu}=200^\circ\text{C}$ 15 W $\vartheta_{Lu}=300^\circ\text{C}$ 29 W $\vartheta_{Lu}=350^\circ\text{C}$ 38 W		$\vartheta_{Lu}=200^\circ\text{C}$ 20 W $\vartheta_{Lu}=300^\circ\text{C}$ 39 W $\vartheta_{Lu}=350^\circ\text{C}$ 51 W		$\vartheta_{Lu}=200^\circ\text{C}$ 40 W $\vartheta_{Lu}=300^\circ\text{C}$ 78 W $\vartheta_{Lu}=350^\circ\text{C}$ 101 W		$\vartheta_{Lu}=200^\circ\text{C}$ 75 W $\vartheta_{Lu}=300^\circ\text{C}$ 145 W $\vartheta_{Lu}=350^\circ\text{C}$ 189 W		$\vartheta_{Lu}=200^\circ\text{C}$ 125 W $\vartheta_{Lu}=300^\circ\text{C}$ 242 W $\vartheta_{Lu}=350^\circ\text{C}$ 315 W			
Belastbarkeit bei Dissipation at $\vartheta_{Lu}=70^\circ\text{C}$ Puissance à $\vartheta_{Lu}=350^\circ\text{C}$	$\vartheta_{Lu}=200^\circ\text{C}$ 12 W $\vartheta_{Lu}=300^\circ\text{C}$ 24 W $\vartheta_{Lu}=350^\circ\text{C}$ 32 W		$\vartheta_{Lu}=200^\circ\text{C}$ 16 W $\vartheta_{Lu}=300^\circ\text{C}$ 32 W $\vartheta_{Lu}=350^\circ\text{C}$ 43 W		$\vartheta_{Lu}=200^\circ\text{C}$ 31 W $\vartheta_{Lu}=300^\circ\text{C}$ 64 W $\vartheta_{Lu}=350^\circ\text{C}$ 87 W		$\vartheta_{Lu}=200^\circ\text{C}$ 58 W $\vartheta_{Lu}=300^\circ\text{C}$ 120 W $\vartheta_{Lu}=350^\circ\text{C}$ 162 W		$\vartheta_{Lu}=200^\circ\text{C}$ 97 W $\vartheta_{Lu}=300^\circ\text{C}$ 200 W $\vartheta_{Lu}=350^\circ\text{C}$ 270 W			
Grenzspannung Limiting voltage Tension limite	750 V		750 V		1000 V		2500 V		3000 V			
Lieferbare Profile Profiles available Profils livrables	1	2	1	2	1	2	1	2	1	2		
Abmessungen in mm Dimensions in mm Dimensions en mm	D	16	16	24	24	24	24	24	24	34	34	
	L	100 ± 2	100 ± 2	100 ± 2	100 ± 2	165 ± 3	165 ± 3	265 ± 3	265 ± 3	330 ± 4	330 ± 4	
	d	8	5,5	14	8,5	14	8,5	14	8,5	22	8,0	
	x	-	7,6	-	10,3	-	10,3	-	10,3	-	10,3	
	y	-	2,0	-	1,6	-	1,6	-	1,6	-	1,8	
Lieferbare Schellenanschlüsse Deliverable tabs Pattes livrables	P	(E)	P	(E)	P	(E)	P	(E)	P	S	(E)	
Abmessungen in mm Dimensions in mm Dimensions en mm	b	6,0	5,0	8,0	8,0	8,0	8,0	8,0	8,0	10	10	8,0
	c	0,5	0,5	0,5	0,8	0,5	0,8	0,5	0,8	0,8	0,8	0,8
	e \varnothing	3,2	3,2	4,3	4,3	4,3	4,3	4,3	4,3	4,3	4,3	4,3
	f _{max}	17,0	22,0	24,0	28,0	24,0	28,0	24,0	28,0	33	-	33
	g _{max}	-	-	-	-	-	-	-	-	-	32	-
	k	5,0	-	5,0	-	10,0	-	10,0	-	20	20	-
	m	-	3,0	-	4,0	-	4,0	-	4,0	-	-	4,0
	n	-	12,0	-	16,0	-	16,0	-	16	-	-	16

Induktionsarme Widerstände „Ni“, siehe Produktbeschreibung.

Non-inductive resistors „Ni“, see product description.

Résistances à faible induction „Ni“, voir description du produit.



Zementierte Drahtwiderstände

Cement-coated wire wound resistors / Résistances bobinées cimentées

Zementierte Drahtwiderstände mit gepunktetem Schellenanschluss (mit verstellbarer Abgreifschelle)

Cemented wire wound resistors with spotwelded radial tabs (with adjustable lugs)

Résistances bobinées cimentées avec bague apparente, soudées par points (à collier ajustable)

ZDSA
ZDRS

Zubehör / Accessories / Accessoires

Bolzenmontage mit Befestigungswinkeln

Retaining bracket with threaded bolt

Equerre de fixation avec tige filetée

Ausführung: Außenwinkel A

Style: Outside bracket A

Modèle: Equerre externe A

Ausführung: Innenwinkel J

Style: Inside bracket J

Modèle: Equerre interne J

Befestigungswinkel W

Retaining bracket W

Equerre de fixation W

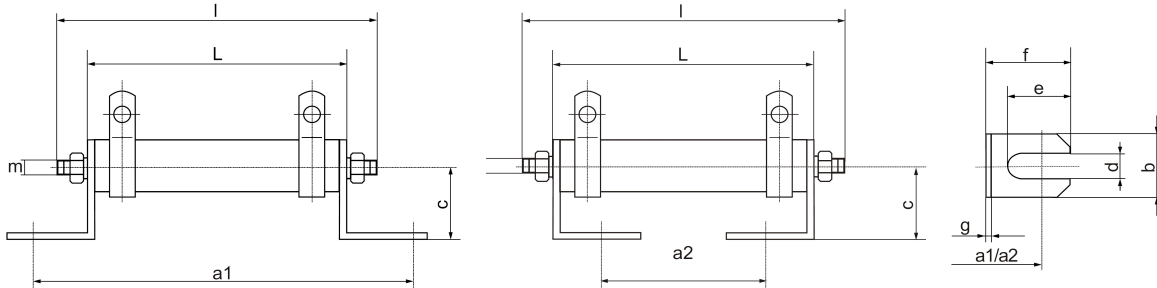

Material: Stahl, verzinkt

Material: steel, galvanized

Matériel: Acier, zingué

Typ Type Type	Für Widerstände D x L For resistors D x L Pour résistances D x L	Bolzen m x l Bolt m x l Tige m x l	Nr.		a1	a2	b	c	d	e	f	g
			W	Z								
B57W1Z0	9 x 45	M3 x 57	W1	Z0	64	29	10	13,5	4,3	11	15	1
B65W1Z0	10 x 50	M3 x 65			69	34						
B74W1Z0	13 x 55	M4 x 74			74	39						
B82W1Z0	13 x 63	M4 x 82			82	47						
B82W2Z0	14 x 63 und/and/et 16 x 63	M4 x 82	W2		82	47	13	16,5				
B118W2Z0	14 x 100 und/and/et 16 x 100	M4 x 118			120	85						
B98W3Z1	21 x 80	M4 x 98	W3	Z1	100	65	20	20	5,3	15	20	1
B118W3Z1	21 x 100	M4 x 118			120	85						
B118W3Z2	24 x 100	M4 x 118		Z2	120	85						
B182W3Z2	24 x 165	M4 x 182			185	150						
B282W3Z2	24 x 265	M5 x 282			285	250						
B118W4Z3	30 x 100	M4 x 118	W4	Z3	126	80	30	30		15	20	
B150W4Z3	30 x 133	M4 x 150			159	113						
B350W4Z4	36 x 330	M5 x 350			Z4	356						

ZO = Scheiben nach DIN 125 - flat washer to DIN 125 - rondelles selon DIN 125

Bestellbeispiel (komplett montiert):

Order designation (fully assembled): 1000 Stück ZDSA 16 x 63-P1 1K0 J A

Code de commande (complètement montée):

Bestellbeispiel (Zubehör lose):

Order designation (as loose accessories): 1000 Stück B 118 W3 Z2

Code de commande (accessoires en vrac):

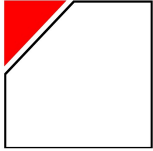

Zementierte Drahtwiderstände

Cement-coated wire wound resistors / Résistances bobinées cimentées

Zementierte Drahtwiderstände mit gepunktetem Schellenanschluss (mit verstellbarer Abgreifschelle)

Cemented wire wound resistors with spotwelded radial tabs (with adjustable lugs)

Résistances bobinées cimentées avec bague apparente, soudées par points (à collier ajustable)

ZDSA
ZDRS

Zubehör / Accessories / Accessoires

Bolzenmontage B

Montage with threaded bolt
Montage avec tige filetée

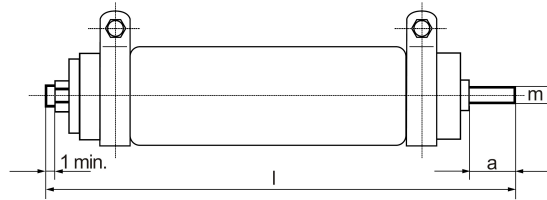

Material: Stahl, verzinkt

Material: steel, galvanized

Matériel: Acier, zingué

Typ Type Type	Für Widerstände D x L For resistors D x L Pour résistances D x L	Bolzen m x l Bolt m x l Tige m x l	a	Z Nr.
B57Z0	9 x 45	M3 x 57	4	Z0
B65Z0	10 x 50	M3 x 65	6	
B74Z0	13 x 55	M4 x 74	8	
B82Z0	13 x 63, 14 x 63 und/and/et 16 x 63	M4 x 82		
B118Z0	14 x 100 und/and/et 16 x 100	M4 x 118		
B98Z1	21 x 80	M4 x 98		Z1
B118Z1	21 x 100	M4 x 118		
B118Z2	24 x 100	M4 x 118	Z2	
B182Z2	24 x 165	M4 x 182		
B282Z2	24 x 265	M5 x 282		
B118Z3	30 x 100	M4 x 118		Z3
B150Z3	30 x 133	M4 x 150		
B350Z4	36 x 330	M5 x 350	10	Z4

Bestellbeispiel (komplett montiert):

Order designation (fully assembled):

1000 Stück ZDSA 16 x 63-P1 1K0 J B

Code de commande (complètement montée):

Bestellbeispiel (Zubehör lose):

Order designation (as loose accessories):

1000 Stück B 118 Z2

Code de commande (accessoires en vrac):

Fußwinkel Formen A und J

Push-in brackets, forms A and J

Equerre de fixation, formes A et J

Außenfußwinkel Form A

External push-in bracket, form A

Equerre de fixation extérieure, forme A

Innenfußwinkel Form J

Internal push-in bracket, form J

Equerre de fixation intérieure, forme J

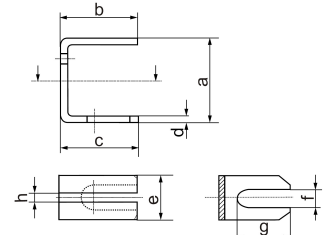
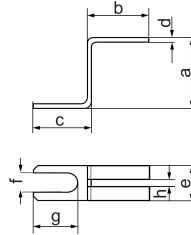

Bestellbeispiel:

Order designation : 1000 Stück A1

Code de commande:

Verwendbar nur für Widerstände mit Fußwinkelprofil.

Suitable for resistors with push-in bracket profile only.

Seulement utilisables pour résistances avec profil en équerre.

Material: Stahl, verzinkt

Steel, Steel, galvanized

Matériel: Acier, zingué

Typ Type Type	Für Widerstände For resistors Pour résistances	a	b	c	d	e	f	g	h
A1	J1 GF 13 x 55	12	11	11	0,6	6	3,2	7,5	1
A2	J2 mit/with/avec D = 16mm Ø	15	14	14	0,8	8	3,2	8	1
A3	J3 mit/with/avec D = 24mm Ø (ohne/without/sans TR)	21	14	14	1	12	4,2	10	2
A4	J4 mit/with/avec D = 30mm Ø	26	22	22	2	16	5,5	16	2
A5	J5 mit/with/avec D = 36mm Ø	32	25	25	2	22	6,5	16	2
A6	J6 (D = 14 mm) GF, ZDFL, ZDST	15	14	14	0,8	7,5	3,2	8	1
A7	J7 (D = 21 mm) GF, ZDFL, ZDST	21	14	14	1	10	4,2	10	2
A8	J8 GSB / ZSB	32	25	25	2	18	5,5	16	2

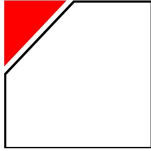

Zementierte Drahtwiderstände

Cement-coated wire wound resistors / Résistances bobinées cimentées

Zementierte Drahtwiderstände mit gepunktetem Schellenanschluss (mit verstellbarer Abgreifschelle)

Cemented wire wound resistors with spotwelded radial tabs (with adjustable lugs)

Résistances bobinées cimentées avec bague apparente, soudées par points (à collier ajustable)

ZDSA
ZDRS

Zubehör / Accessories / Accessoires

Zentrierscheiben Z (für die Montage von Widerständen mit durchgehendem Bolzen)

Centring washer Z (for mounting of resistors with bolts)

Rondelles Z (pour le montage de résistances avec tenons)

Typ Type Type	Da	Di _{max}	d	s	h
Z1	13	8	4,3	0,5	1,5
Z2	17	10	5,3	1	2
Z3	27	14	5,3	1	2
Z4	30	18	5,3	0,5	1,5

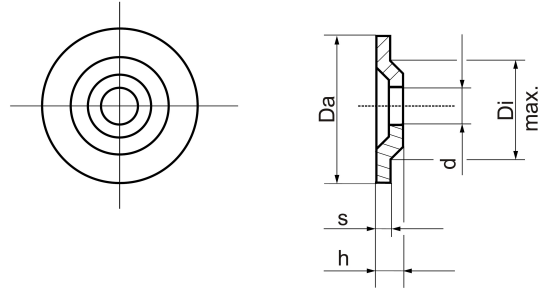

ZO = Scheiben nach DIN 125 - flat washer to DIN 125 - rondelles selon DIN 125

Bestellbeispiel:

Order designation: 1000 Stück Z2

Code de commande:

Material: Stahl, verzinkt

Material: steel, galvanized

Matériel: acier, zingué

Keramische Zentrierscheibe

Ceramic centring washer

Disques de centrage en céramique

Typ Type Type	Abmessung, Dimensions (mm)					
	Da	Di	d	d ₁	a	b
KSZ I	20	7,1	4,5	10	10	5
KSZ II	20	9,5	5	10	10	5
KSZ III	30	17,5	5	12	10	5
KSZ IV	30	19,2	6	12	10	5
KSZ V	40	29,2	6	12	10	5

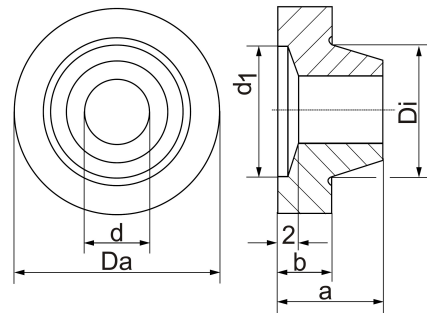

Bestellbeispiel/ Order designation/ Code de commande: 1000 Stück KZS II

Keramische Scheibe

ceramic washer

disques en céramique

Typ Type Type	Abmessung, Dimensions (mm)		
	D	d	s
KS I	6	2,3	5
KS II	8	3,5	5
KS III	10	5,5	5
KS IV	13	5,5	5

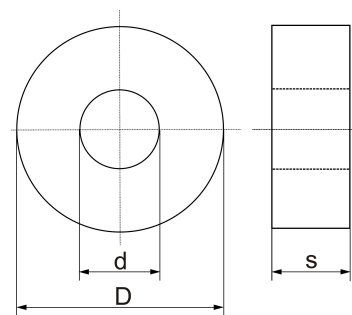

Bestellbeispiel/ Order designation/ Code de commande: 1000 Stück KS III

KRAH ELEKTRONISCHE BAUELEMENTE GMBH, Märkische Straße 4, 57489 Drolshagen, Telefon: 02761/701-0, Telefax: 02761/701-177