

Bolzenmontage mit Befestigungswinkeln

Retaining bracket with threaded bolt
Equerre de fixation avec tige filetée

Ausführung: Außenwinkel A

Style: Outside bracket A
Modèle: Equerre externe A

Ausführung: Innenwinkel J

Style: Inside bracket J
Modèle: Equerre interne J

Befestigungswinkel W

Retaining bracket W
Equerre de fixation W

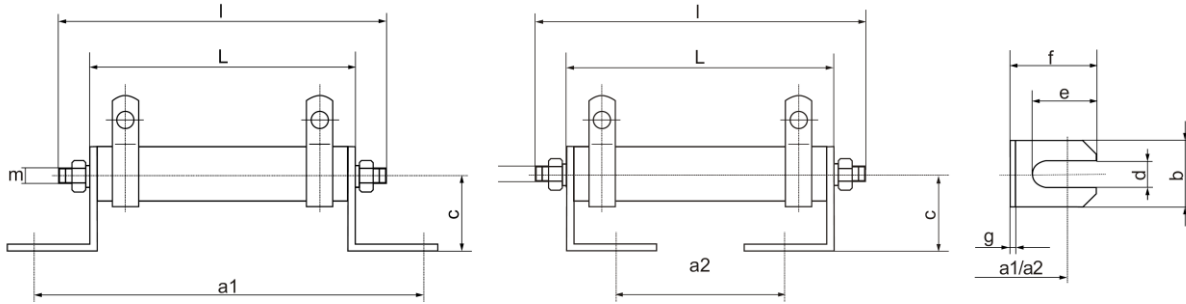

Material: Stahl, verzinkt
Material: steel, galvanized
Matériel: Acier, zingué

Typ Type Type	Für Widerstände D x L For resistors D x L Pour résistances D x L	Bolzen m x l Bolt m x l Tige m x l	W	Z	a1	a2	b	c	d	e	f	g
B57W1Z0	9 x 45	M3 x 57	W1	Z0	64	29	10	13,5	4,3	11	15	1
B65W1Z0	10 x 50	M3 x 65			69	34						
B74W1Z0	13 x 55	M4 x 74			74	39						
B82W1Z0	13 x 63	M4 x 82			82	47						
B82W2Z0	14 x 63 und/and/et 16 x 63	M4 x 82	W2	Z0	82	47	13	16,5	4,3	11	15	1
B118W2Z0	14 x 100 und/and/et 16 x 100	M4 x 118			120	85						
B98W3Z1	21 x 80	M4 x 98	W3	Z1	100	65	20	20	5,3	11	15	1
B118W3Z1	21 x 100	M4 x 118			120	85						
B118W3Z2	24 x 100	M4 x 118		Z2	120	85						
B182W3Z2	24 x 165	M4 x 182			185	150						
B282W3Z2	24 x 265	M5 x 282	W4	Z3	285	250	30	30	5,3	15	20	1
B118W4Z3	30 x 100	M4 x 118			126	80						
B150W4Z3	30 x 133	M4 x 150			159	113						
B350W4Z4	36 x 330	M5 x 350			356	310						

Z0 = Scheiben nach DIN 125 - flat washer to DIN 125 - rondelles selon DIN 125

Bestellbeispiel (komplett montiert):

Order designation (fully assembled): 1000 Stück GS 13 x 55 C - 1 K0 J A
Code de commande (complètement montée):

Bestellbeispiel (Zubehör lose):

Order designation (as loose accessories): 1000 Stück B 118 W3 Z2
Code de commande (accessoires en vrac):

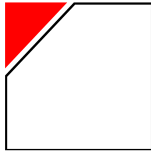

Zubehör
Accessories
Accessoires

Bolzenmontage B

Montage with threaded bolt
Montage avec tige filetée

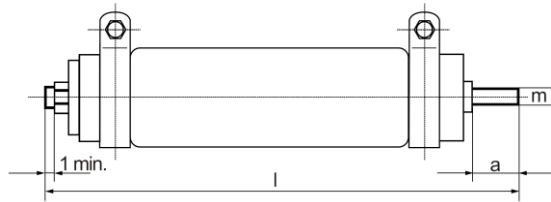

Material: Stahl, verzinkt
Material: steel, galvanized
Matériel: Acier, zingué

Typ Type Type	Für Widerstände D x L For resistors D x L Pour résistances D x L	Bolzen m x l Bolt m x l Tige m x l	a	Z Nr.
B57Z0	9 x 45	M3 x 57	4	Z0
B65Z0	10 x 50	M3 x 65	6	
B74Z0	13 x 55	M4 x 74	8	
B82Z0	13 x 63, 14 x 63 und/and/et 16 x 63	M4 x 82		
B118Z0	14 x 100 und/and/et 16 x 100	M4 x 118		
B98Z1	21 x 80	M4 x 98		Z1
B118Z1	21 x 100	M4 x 118		
B118Z2	24 x 100	M4 x 118		Z2
B182Z2	24 x 165	M4 x 182		
B282Z2	24 x 265	M5 x 282		Z3
B118Z3	30 x 100	M4 x 118		
B150Z3	30 x 133	M4 x 150		Z4
B350Z4	36 x 330	M5 x 350	10	

Bestellbeispiel (komplett montiert):

Order designation (fully assembled): 1000 Stück GS 13 x 55 C - 1 K0 J B

Code de commande (complètement montée):

Bestellbeispiel (Zubehör lose):

Order designation (as loose accessories): 1000 Stück B 118 Z2

Code de commande (accessoires en vrac):

Traversen

Mounting devices
Supports

Typ K für Kappenwiderstände

Type K for assembly of resistors with ferrules
Type K pour le montage de résistance avec bagues

Typ S für Schellenwiderstände

Type S for assembly of resistors with tabs
Type S pour le montage de résistance avec pattes

Federweg x = 11 mm

Feather way x = 11 mm
Course du ressort de tension x = 11 mm

Schwarz lackiert

Lacquer finish: black
Couche de vernis: noir

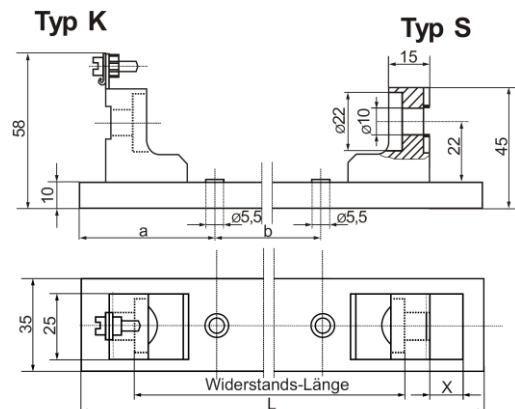

Typ Type Type	Für Widerstände D x L For resistors D x L Pour résistances D x L	L ±2mm	a mm	b mm	Gewicht in g
S100	GS 24 x 100 TR / ZS 24 x 100 TR	149	51	40	300
S165	GS 24 x 165 TR / ZS 24 x 165 TR	218	51	70	445
S265	GS 24 x 265 TR / ZS 24 x 265 TR	318	96	115	600
K100	GK 24 x 100 / ZS 24 x 100 Auf Anfrage	149	51	40	300
K165	GK 24 x 165 / ZS 24 x 165 On request	218	51	70	445
K265	GK 24 x 265 / ZK 24 x 265 Sur commande	318	96	115	600

Zulässige Betriebsspannung gegen Erde: 5 kV

Permissible operating voltage to ground: 5 kV
Rigidité diélectrique à la masse: 5 kV

Bestellbeispiel:

Order designation: 1000 Stück Traversen K100
Code de commande:

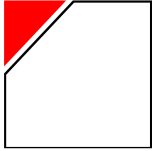

Zubehör
Accessories
Accessoires

Haltefeder, Form H (Lyrafeder)
Spring clip, form H
Clips de tension, forme H

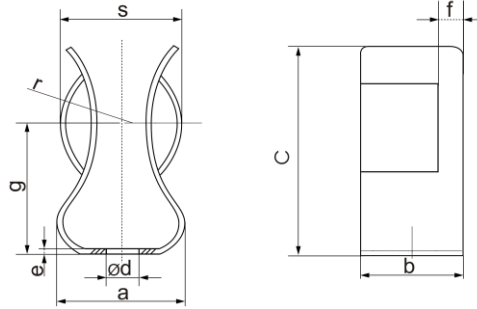

Material: Messing vernickelt
Material: Brass nickel platin
Matériel: Laiton nickelage

Verwendbar nur für Widerstände mit Kappen.
Suitable for resistors with ferrules only.
Seulement utilisables pour résistances avec bagues.

Typ Type Type	Für Widerstände For resistors Pour résistances	a	b	c	dØ	e	f	g	r	s
H16	GK, ZK und/and/et UK (D = 16mm Ø)	15	10	24	4,5	0,6	2	16	7	11,5
H24	GK, ZK und/and/et UK (D = 24mm Ø)	20	15	31	4,5	0,8	2	20	10,5	18

Bestellbeispiel:
Order designation: 1000 Stück H16
Code de commande:



Zubehör
Accessories
Accessoires

Fußwinkel Formen A und J

Push-in brackets, forms A and J
Equerre de fixation, formes A et J

Außenfußwinkel Form A

External push-in bracket, form A
Equerre de fixation extérieure, forme A

Innenfußwinkel Form J

Internal push-in bracket, form J
Equerre de fixation intérieure, forme J

Bestellbeispiel:

Order designation : 1000 Stück A1
Code de commande:

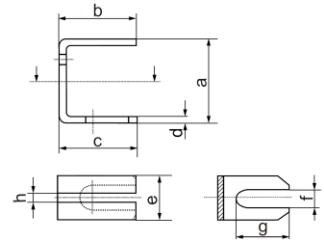
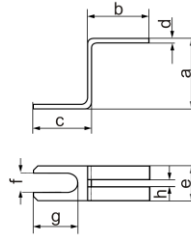

Verwendbar nur für Widerstände mit Fußwinkelprofil.

Suitable for resistors with push-in bracket profile only.
Seulement utilisables pour résistances avec profil en équerre.

Material: Stahl, verzinkt

Steel, Steel, galvanized
Matériel: Acier, zingué

Typ Type Type	Für Widerstände For resistors Pour résistances	a	b	c	d	e	f	g	h	
A1	J1	GF 13 x 55	12	11	11	0,6	6	3,2	7,5	1
A2	J2	mit/with/avec D = 16mm Ø	15	14	14	0,8	8	3,2	8	1
A3	J3	mit/with/avec D = 24mm Ø (ohne/without/sans TR)	21	14	14	1	12	4,2	10	2
A4	J4	mit/with/avec D = 30mm Ø	26	22	22	2	16	5,5	16	2
A5	J5	mit/with/avec D = 36mm Ø	32	25	25	2	22	6,5	16	2
A6	J6	(D = 14 mm) GF, ZDFL, ZDST	15	14	14	0,8	7,5	3,2	8	1
A7	J7	(D = 21 mm) GF, ZDFL, ZDST	21	14	14	1	10	4,2	10	2
A8	J8	GSB / ZSB	32	25	25	2	18	5,5	16	2

Befestigungswinkel W

Retaining bracket W
Equerre de fixation W

für die Montage von Widerständen mit durchgehenden Bolzen

for assembly of resistors with bolts
pour le montage de résistance avec tenons

Bestellbeispiel:

Order designation: 500 Stück W6
Code de commande:

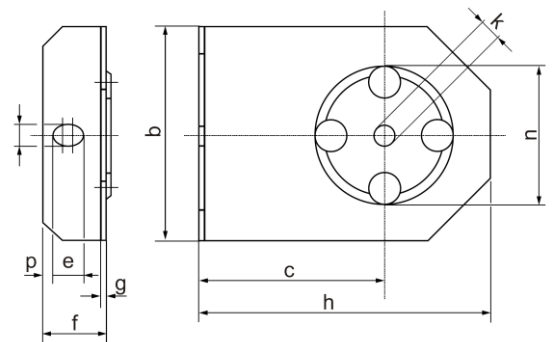

Material: Stahl, verzinkt

Material: steel, galvanized
Matériel: Acier, zingué

Typ Type Type	Für Widerstände D x L For resistors Pour résistances	Bolzen m x l Bolt m x l Tige m x l	mm									
			b	c	d	e	f	g	h	k	n	p
W5	GLS 32 x 330	M4 x 350	35	32,5	4,2	8	15	1	50	4,3	20	3
W6	GFB 45 x 330	M5 x 350	45	42,5	5,5	9	19	1,5	65	5,3	27	5
	GFB 45 x 370	M5 x 390										
W7	GFB 60 x 370	M6 x 390	70	60	6,5	9	20	1,5	95	6,3	44	4



Zubehör

Accessories
Accessoires

Fußwinkel, Form Z, zur Montage von Widerständen mit verdrehsicherem Profil

Base clip, style Z, for mounting of resistors with non-rotatable profile

Équerre-pied en forme de Z, pour le montage de résistances à profil résistant à la torsion

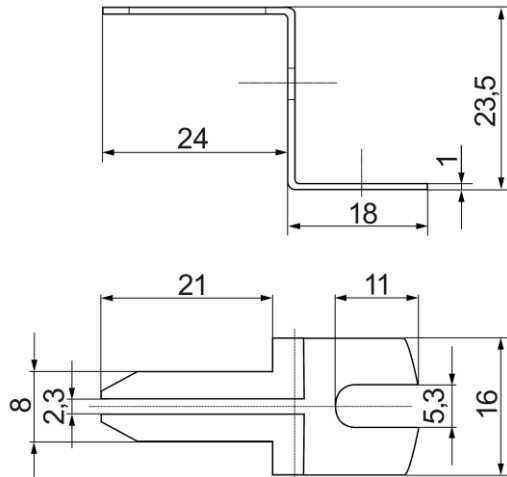

Material: Stahl, verzinkt
Material: Steel, galvanized
Matériel: Acier, zingué

Für Widerstände: ZDST 14 x 45
For resistors: ZDST 14 x 64
Pour résistances: ZDST 14 x 80
ZDST 14 x 100
ZDFL 14 x 45
ZDFL 14 x 64
ZDFL 14 x 80
ZDFL 14 x 100

Bestellbeispiel:

Order designation : 1000 Stück 4.40.02

Code de commande:

Die Widerstände können auf Wunsch auch mit komplett montierten Fußwinkeln geliefert werden.

On request, the resistors can also be supplied with ready-mounted base clips.

Les résistances peuvent être livrées, sur demande, avec équerres-pieds complètement montées.

Befestigungsteile für FH und FTH

Fixing devices for FH and FTH

Pièces de fixation pour FH et FTH

SY8,5

SY8,5/1

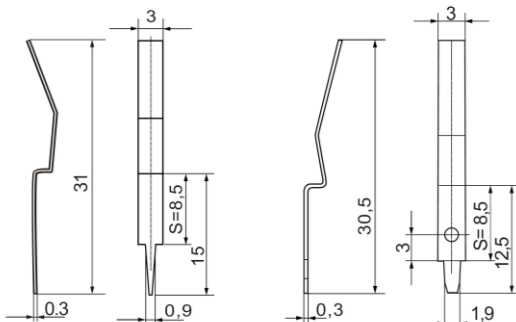

S = Abstand des Widerstandes von der Leiterplatte

S = Distance of the resistor to conductive plate

S = Distance de la résistance à la plaque conductrice

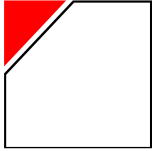

Zubehör
Accessories
Accessoires

Zentrierscheiben Z (für die Montage von Widerständen mit durchgehendem Bolzen)

Centring washer Z (for mounting of resistors with bolts)
Rondelles Z (pour le montage de résistances avec tenons)

Typ Type Type	Da	Di _{max}	d	s	h
Z1	13	8	4,3	0,5	1,5
Z2	17	10	5,3	1	2
Z3	27	14	5,3	1	2
Z4	30	18	5,3	0,5	1,5

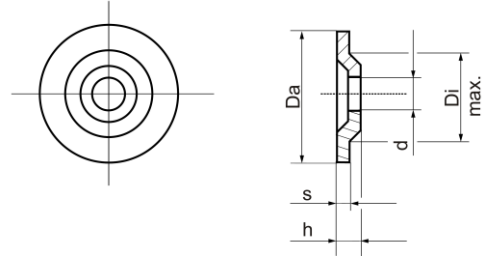

ZO = Scheiben nach DIN 125 - flat washer to DIN 125 - rondelles selon DIN 125

Bestellbeispiel:

Order designation: 1000 Stück Z2
Code de commande:

Material: Stahl, verzinkt

Material: steel, galvanized
Matériel: acier, zingué

Keramische Zentrierscheibe

ceramic centring washer
disques de centrage en céramique

Typ Type Type	Abmessung, Dimensions (mm)					
	Da	Di	d	d ₁	a	b
KSZ I	20	7,1	4,5	10	10	5
KSZ II	20	9,5	5	10	10	5
KSZ III	30	17,5	5	12	10	5
KSZ IV	30	19,2	6	12	10	5
KSZ V	40	29,2	6	12	10	5

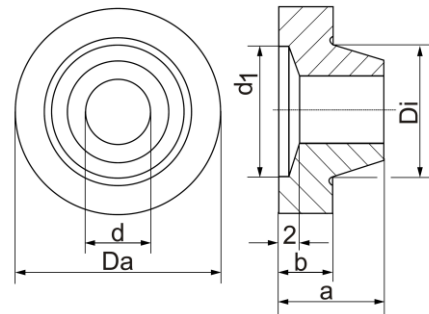

Bestellbeispiel/ Order designation/ Code de commande: 1000 Stück KZS II

Keramische Scheibe

ceramic washer
disques en céramique

Typ Type Type	Abmessung, Dimensions (mm)		
	D	d	s
KS I	6	2,3	5
KS II	8	3,5	5
KS III	10	5,5	5
KS IV	13	5,5	5

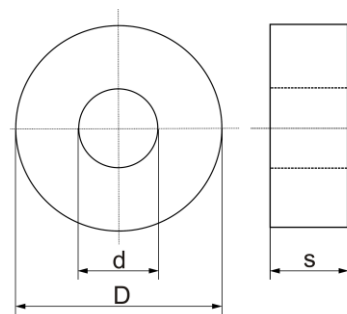

Bestellbeispiel/ Order designation/ Code de commande: 1000 Stück KS III