



Hybrid Power

Charger and Modules 480V

AC/DC charger & 480V Ultracapacitor storage

- Innovative in energy storage & Power Electronics
- Custom-made solutions
- Complete solution: storage & Power Electronics
- Design and system integration



Features

- Long life cycle and life time
- CAN-bus interface
- Current sensing
- Specifications can be customized
- Programmable AC/DC charge
- Approved for heavy-duty shock and vibration norms
- EMC and temperature certified
- Intelligent platform

Mechanical Data

Charger

Length x Width x Height

137 x 270 x 75 mm (w/o connector lengths)

Approx. 3,0 kg

Module (x3)

Length x Width x Height

646 x 155 x 81 mm (w/o connector lengths)

Approx. 9,5 kg

Applications

- UPS wind turbine pitching
- Wind turbine LVRT
- Warehouse / logistic AGV
- UPS
- Industrial
- Power supplies

aephybridpower.com
 sales@aephybridpower.com
 +31 (0)78 692 2100



System Specifications

Symbol	Parameter	Description	Value	Unit
	Capacitance			
C_s	Rated capacitance		1,83	F
	Tolerance capacity		+20/-0	%
	Voltage			
U_{NOM}	Nominal voltage		480	VDC
U_{MAX}	Max. operation voltage		518,4	VDC
	Resistance			
ESR_{DC}	Internal resistance		600	mΩ
	Power (Cells in module housing)			
	Rated Power	@ V_r and ESR_{DCmax}	96	kW
	Energy (module)			
E_{max}	Energy	@ V_{max}	68,3	Wh
E_{ava}	Available	Between V_{max} and $\frac{1}{2} V_{max}$	51,3	Wh

AC/DC Charger Specifications

Symbol	Parameter	Description	Value	Unit
	General			
P_r	Rated power	@ U_{sr} 480VDC, I_{charge} 3A	1440	W
f_r	Switching frequency		20	kHz
η_r	Efficiency		>90	%
	Primary side			
U_{pr}	Rated voltage		400	VAC ±10%
$U_{p,max}$	Max. operating voltage		440	VAC
	Secondary side			
U_{sr}	Rated voltage		480	VDC
$U_{s,max}$	Max. operating voltage		500	VDC
I_{charge}	Charge current		3	A
	Energy demand			
	Control voltage		24	VDC ±10%
	Control current		0,5	A



Capacitor Module Specifications

Symbol	Parameter	Description	Value	Unit
	Capacitance			
C _s	Rated capacitance		5,47	F
	Tolerance capacity		+20/-0	%
	Voltage			
U _{NOM}	Nominal charging voltage		160	VDC
U _{MAX}	Max. operating voltage		172,8	VDC
U _{ISO}	Isolation voltage		600	VDC
	Resistance			
ESR _{DC}	Internal resistance		200	mΩ
	Environment			
T _a	Operating temperature range		-40 till +65	°C
T _{STORAGE}	Storage temperature range		-40 till +70	°C
	Protection class		IP40	
	Power (cells only)			
P _d	Rated power density	@V _r and ESR,DC _{max}	8,01	kW/kg
P _{max}		@V _{max} and ESR,AC	9,35	kW/kg
	Power (cells in module housing)			
P _d	Rated power density	@V _r and ESR,DC _{max}	3,26	kW/kg
P _{max}		@V _{max} and ESR,AC	3,79	kW/kg
	Energy (module)			
E _{max}	Energy density	@V _{max}	2,4	kW/kg
E _{ava}	Available energy	Between V _{max} and ½ V _{max}	17,8	Wh
	Current			
I _{AVG}	Rated continuous current		25	A
I _{LEAK}	Leakage current	After 72 hours at 25°C	0,3	mA



Cap Monitoring Block

With more than two modules, a “monitoring board” is needed to combine the module OK- and temperature signals.

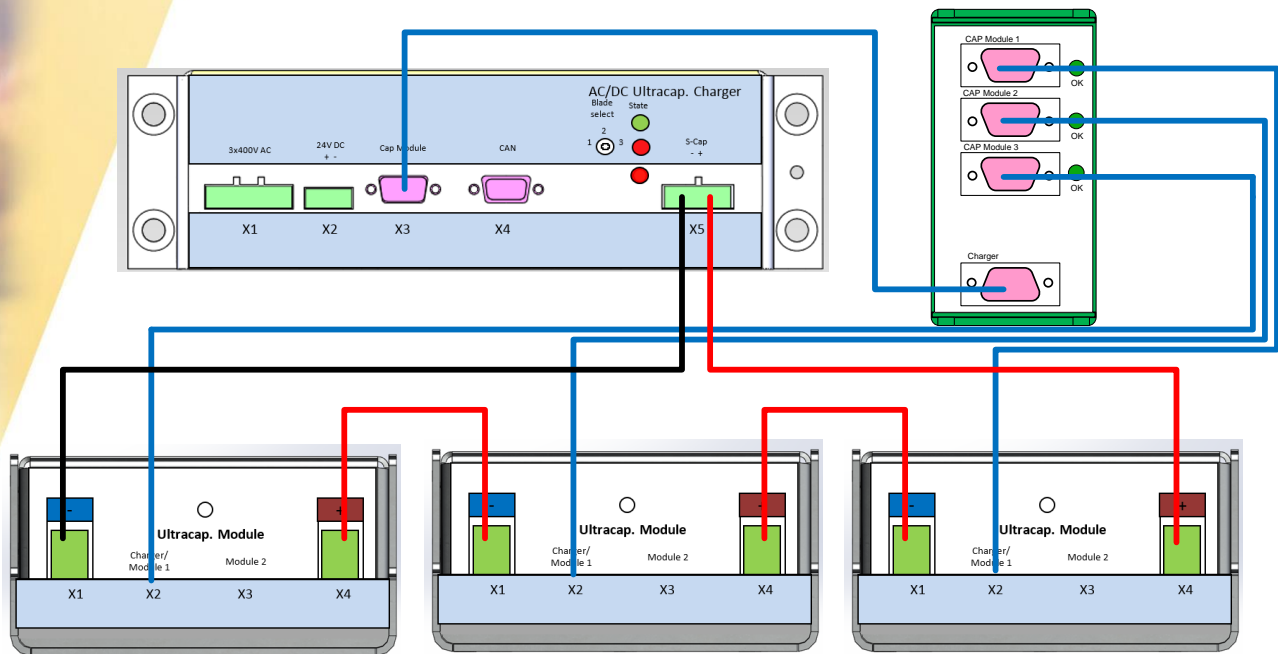

Mechanical data – AC/DC Charger

Length x Width x Height:

137 x 270 x 75 mm (w/o connector lengths)

Weight:

3,0 kg

Housing:

IP40 (connector IP20)

Mounting:

DIN rail mounting on l x h side

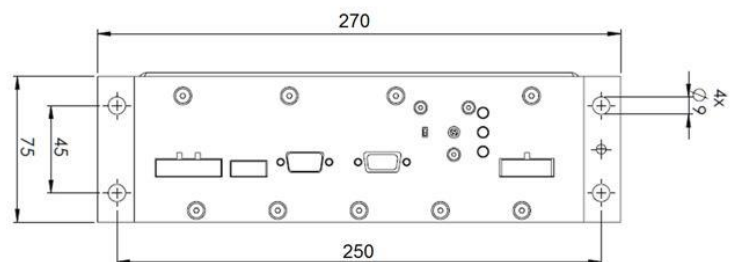
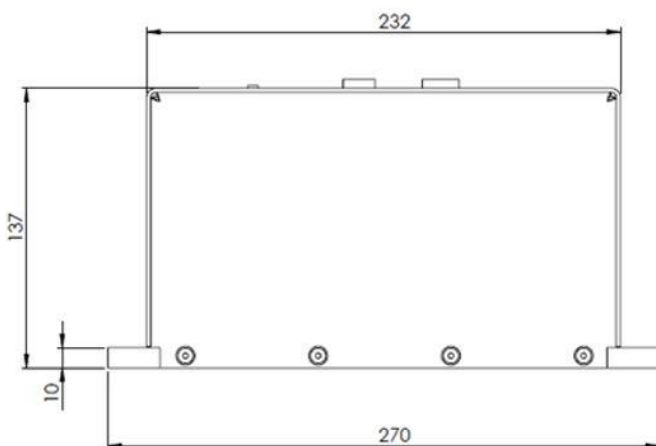

Mechanical data – Capacitor Module (3x)

Length x Width x Height:	646 x 155 x 81 mm
Weight:	9,5 kg
Housing:	IP40 (connector IP20)
Mounting:	DIN rail mounting on l x w side

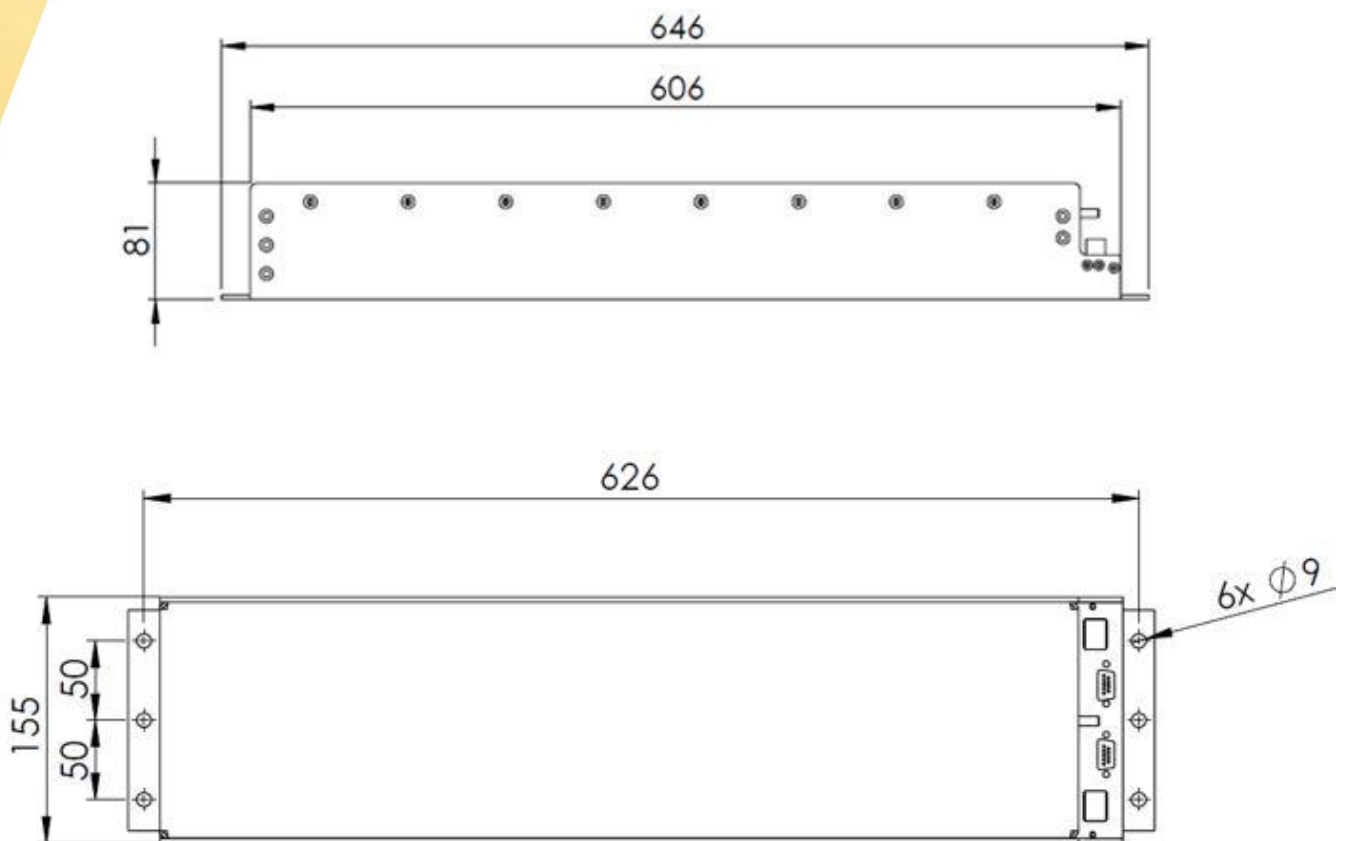

Certifying Tests

Description	Conditions
IEC60068	Shock and vibration
EN 61000	Electric Magnetic Compatibility (EMC)
	Temperature test -40°C till 60°C