

4

3

2

1

NOTES UNLESS OTHERWISE SPECIFIED:

- 1. NOMENCLATURE: VALVE, BREATHER, TWO-WAY RELIEF WITH MANUAL RELEASE BUTTON.
- 2. APPLICABLE SPECIFICATION: SAE AS27166, TYPE III, WITH MODIFIED PERFORMANCE AS SHOWN BELOW.
- 3. PERFORMANCE:
  - 3.1 AIR FLOW IN DIRECTION "P" (OUT OF CONTAINER):
    - 3.1.1 VALVE SHALL CRACK BETWEEN 0.50 AND 1.0 PSID.
    - 3.1.2 VALVE SHALL RESEAL AFTER CRACK BY 0.50 PSID MINIMUM.
    - 3.1.3 MINIMUM AIR FLOW SHALL BE 3.00 SCFM BY 2.00 PSID.
  - 3.2 AIR FLOW IN DIRECTION "V" (INTO CONTAINER):
    - 3.2.1 VALVE SHALL CRACK BETWEEN 0.50 AND 1.0 PSID.
    - 3.2.2 VALVE SHALL RESEAL AFTER CRACK BY 0.50 PSID MINIMUM.
    - 3.2.3 MINIMUM AIR FLOW SHALL BE 4.00 SCFM BY 2.00 PSID.
- 4. THIS VALVE IS NOT REPAIRABLE EXCEPT BY AGM CONTAINER CONTROLS, INC.
- 5. THE FOLLOWING ITEMS FURNISHED AS PART OF THE ASSEMBLY MAY BE PURCHASED SEPARATELY:
 

P/N	300200	GASKET, RETAINED & NUT
	300003-16	NUT
- 6. MATERIALS:
  - 6.1 HOUSING, SCREEN, RELEASE BUTTON, AND NUT: ALUMINUM ALLOYS.
  - 6.2 GASKETS, RETAINED & NUT: SILICONE RUBBER IAW A-A-59588, CLASS 2A OR 2B, GRADE 60.
- 7. FINISH:
  - 7.1 HOUSING: ANODIZED IAW MIL-A-8625, TYPE II, CLASS 2, DYED BLACK.
  - 7.2 NUT: ANODIZED IAW MIL-A-8625, TYPE II, CLASS 1.
  - 7.3 RELEASE BUTTON: ANODIZED IAW MIL-A-8625, TYPE II, CLASS 2, DYED RED.

REVISIONS				
ZONE	LTR.	DESCRIPTION	DATE	APPROVED

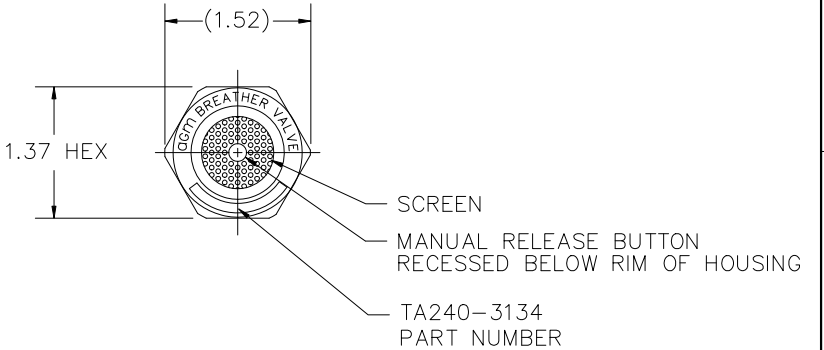

↑ (OUT OF CONTAINER)  
↓ (INTO CONTAINER)

AIR FLOW "P"  
AIR FLOW "V"

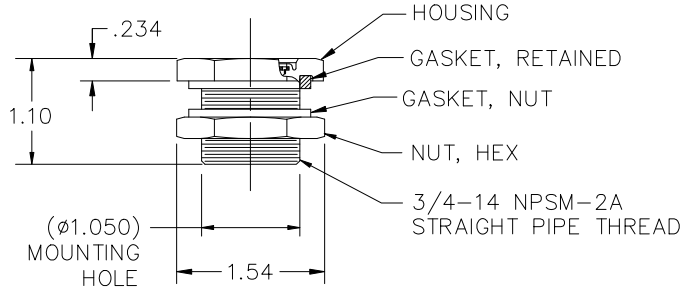

INTERPRET DIMENSIONS AND TOLERANCES IAW ASME Y14.5M-1994 UNLESS OTHERWISE SPECIFIED DIMENSIONS ARE IN INCHES TOLERANCES: DECIMALS .XX ±.015 .XXX ±.010 ANGLES ±.5°				CONTRACT	
				DRAWN P. LANE	DATE 12-6-2017
DO NOT SCALE DRAWING				APPROVED	
FINISH 7.				MANUFACTURING	
PART DASH NO.	NEXT QTY. REQ'D PER ASSY.	FINAL	NEXT ASSY.	USED ON	SIMILAR TO
APPLICATION			ACT. WT.	SALC. WT.	CUSTOMER

<b>AGM CONTAINER CONTROLS, INC.</b> <small>P.O. BOX 40020 - TUCSON, ARIZONA 85717-0020</small>			
<b>VALVE, BREATHER</b>			
SIZE C	FSCM NO. 08992	DWG. NO. TA240-3134	REV -
SCALE 1/1	RELEASE DATE	SHEET 1 OF 1	