



Breather Valves

INCLUDES VALVES THAT KEEP DUST, WATER AND BLOWING SAND FROM ENTERING CONTAINERS.



ISO 9001:2008 REGISTERED

AGM CONTAINER CONTROLS, INC.
PO BOX 40020 • TUCSON ARIZONA 85717-0020
TEL: 800-995-5590 (520) 881-2130 • FAX: (520) 881-4983
www.agmcontainer.com • sales@agmcontainer.com



Sustaining Member

CATALOG 03B



Breather Valves

AGM CONTAINER CONTROLS, INC.
PO BOX 40020 • TUCSON ARIZONA 85717-0020
TEL: 800-995-5590 (520) 881-2130 • FAX: (520) 881-4983
www.agmcontainer.com • sales@agmcontainer.com

THEORY & CHARACTERISTICS

WHY USE BREATHER VALVES?

In the packaging of missiles, engines and delicate electronic gear, it is essential to protect equipment from the effects of moisture. In order to accomplish this, the shipping and/or storage containers must be tightly sealed and desiccated. However, these containers may be exposed to pressure and vacuum differentials of as much as 5.7 psid (pounds per square inch differential) due to temperature and/or altitude changes. To resist pressures of this magnitude, the container would need to be constructed from a very strong material, which would make it bulky, heavy and costly to store and ship.

This problem can be overcome by the use of a "controlled breathing" system, or breather valves. These low-pressure, high-flow valves automatically adjust the container pressure with respect to environmental pressure changes and prevent excessive pressure differentials during air or high altitude truck or rail transport (**Fig. 1**).

At one time, "free-breathing" containers were considered as an alternative solution to this problem. The theory, based on Ficke's Law, was that moisture would not pass freely through tubes with lengths 10 or more times

their diameters. However, this principle applies only when there is no pressure differential between the two ends of the tube. The method was found to be unsatisfactory in actual practice. In fact, in tests conducted by the U.S. Army Tank Automotive Command, the average water gain in three free-breathing containers was over six times greater than a controlled breathing container with a valve which sealed at 0.5 psid pressure and 1.0 psid vacuum (See Appendix - p. 22).

HOW WILL BREATHER VALVES PROTECT THE CONTENTS OF A CONTAINER FROM MOISTURE INTRUSION?

The answer to this question depends on five factors:

- (1) The pressure and vacuum settings of the valves.
- (2) The temperature variations to be encountered during storage.
- (3) The temperature and relative humidity of the storage area(s).

Both of these containers were designed to hold the same missile. **BREATHER VALVES MADE IT POSSIBLE TO SIGNIFICANTLY REDUCE WEIGHT & BULK!**



ENGINE TYPE CONTAINER

Length---138 in.
Width----44 in.
Height---47 in.
Cube----165 Cu. Ft.
WEIGHT---750 POUNDS



BREATHING CONTAINER

Length----132 in.
Width-----33 in.
Height----36 in.
Cube----90 Cu. Ft.
WEIGHT---350 POUNDS



Breather Valves

AGM CONTAINER CONTROLS, INC.
PO BOX 40020 • TUCSON ARIZONA 85717-0020
TEL: 800-995-5590 (520) 881-2130 • FAX: (520) 881-4983
www.agmcontainer.com • sales@agmcontainer.com

THEORY & CHARACTERISTICS

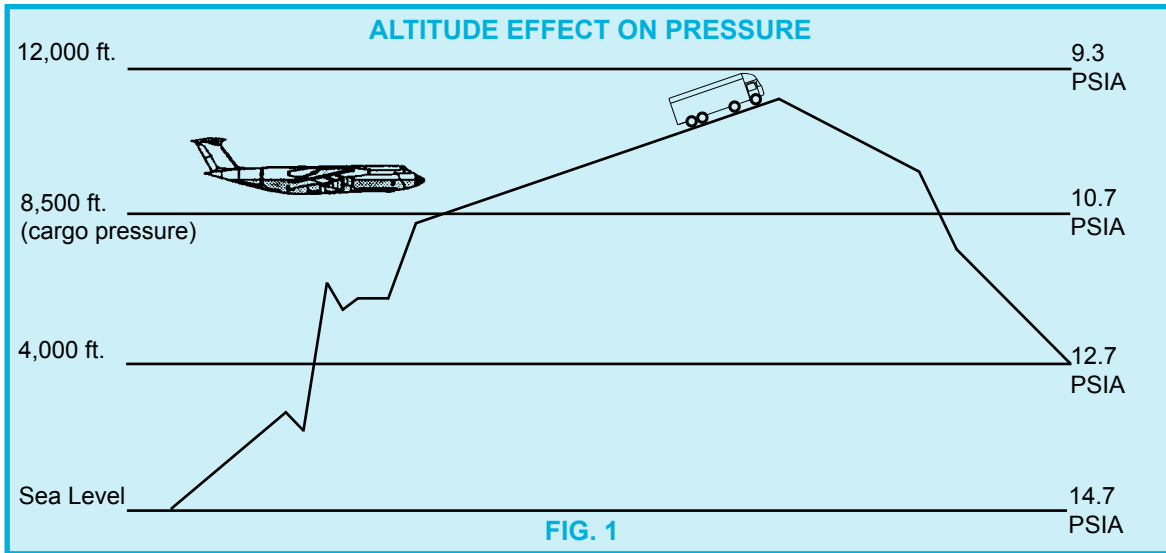

FIG. 1

- (4) The number of airlifts which the container might experience.
- (5) The amount of desiccant in the container.

1. PRESSURE AND VACUUM SETTINGS

Breather valves are made in a variety of settings, ranging from 0.2 psid to 5.0 psid or more. These settings, which are the points at which the valves seal, must be at least 1.0 psi to 1.5 psi below the pressure or vacuum which the container can safely withstand without leaking or deforming (See "How To Select the Right Valve"). Generally speaking, the lower the valve setting, the more often the valve will open, admitting outside atmosphere and shortening the life of the desiccant.

2. TEMPERATURE VARIATIONS DURING STORAGE

The number of times a breather valve will open during storage depends not only on the valve setting, but also on the magnitude and frequency of temperature variations which may occur in a particular storage area. In sealed containers there is a pressure change ranging from 1.0 to 1.5 psi for each 30°F temperature change (Fig. 2).

Long-term tests, which have been run on containers at AGM's plant in Tucson, Arizona, indicate that valves with sealing pressures of 0.25 psid will open almost every day, while valves set to reseal at 0.5 psid may open up to 150 times a year, and valves set for 1.0 psid rarely open during storage. (It should be noted that these tests were run on

rigid wall containers, and that low-setting valves on plastic containers with flexible walls will probably not open as often under the same conditions.) There are only a few locations in the world where greater diurnal temperature variations occur than Tucson. Therefore, under worldwide storage conditions, valves with a 0.5 psid reseal in both directions will open no more than 200 times a year, and valves set for a 1.0 psid reseal in both directions will probably open less than a dozen times.

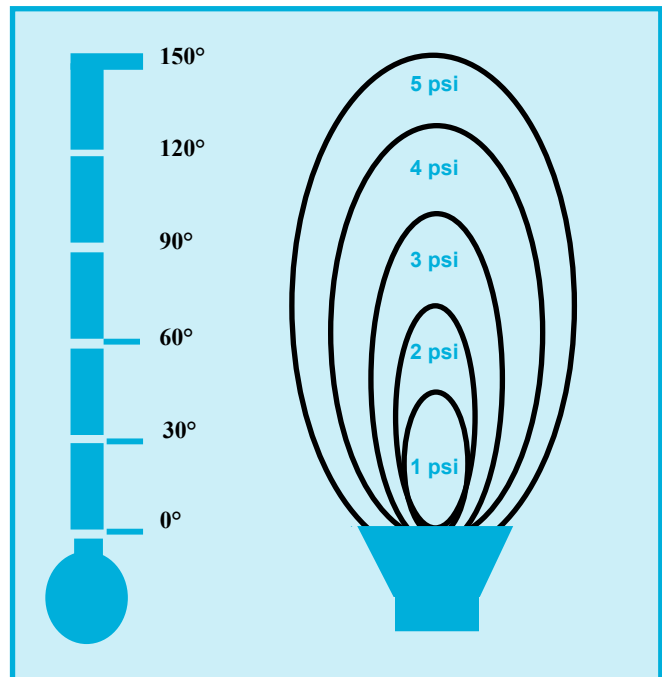

Fig. 2



Breather Valves

AGM CONTAINER CONTROLS, INC.
PO BOX 40020 • TUCSON ARIZONA 85717-0020
TEL: 800-995-5590 (520) 881-2130 • FAX: (520) 881-4983
www.agmcontainer.com • sales@agmcontainer.com

THEORY & CHARACTERISTICS

3. TEMPERATURE VERSUS HUMIDITY

In addition to the number of times the valve opens, the amount of moisture taken into the container at each opening (or “gulp”) will determine desiccant life, and this is dependent on the climatic conditions of the storage area. There are places in the world where as much as 0.015 grams of water per container cubic foot could be taken in at each “gulp”. (Reference NavWeps Report 8374, Table XII). However, high humidity tends to limit temperature variations (**Fig. 3**), so that even breather valves with very low settings will probably not open more than 2 or 3 times a year in these locations.

4. NUMBER OF AIRLIFTS

For each descent from 10.7 psia (normal pressurization level in an aircraft cargo compartment) to 14.7 psia (sea level), a breather valve set for 0.5 psid reseal in both directions will take in approximately 0.013 grams of water per cubic foot of container volume. Higher or lower valve settings will not substantially vary the amount of moisture gain per descent. Therefore, the amount of desiccant needed will, in part, depend on the number of airlifts anticipated.

5. AMOUNT OF DESICCANT

It has been noted above that:

1. in ground storage, each time a container must breathe it will take in as much as 0.015 grams of water per cubic foot, and
2. during each air descent in a pressurized cargo compartment it will take in as much as 0.013 grams of water per cubic foot.

Since MIL-STD-2073-I requires 1.2 units of desiccant per cubic foot in a sealed rigid metal container (plus additional amounts for dunnage, if any) and one unit of desiccant will hold 6.0 grams of water at 40% relative humidity (RH) at 77°F, this amount of desiccant will protect the container for a total of 480 “gulps” in ground storage, or a total of 550 airlifts, or some combination of the two.

Keeping the above factors in mind, we see that a breather valve, properly selected and used in conjunction with adequate desiccant, can provide years of moisture protection in a lightweight, low cost container.

HOW TO SELECT THE RIGHT VALVE

The breather valve must perform two functions:

1. limit the amount of moisture that can enter the container, and
2. protect the container itself from excessive pressure or vacuum differentials.

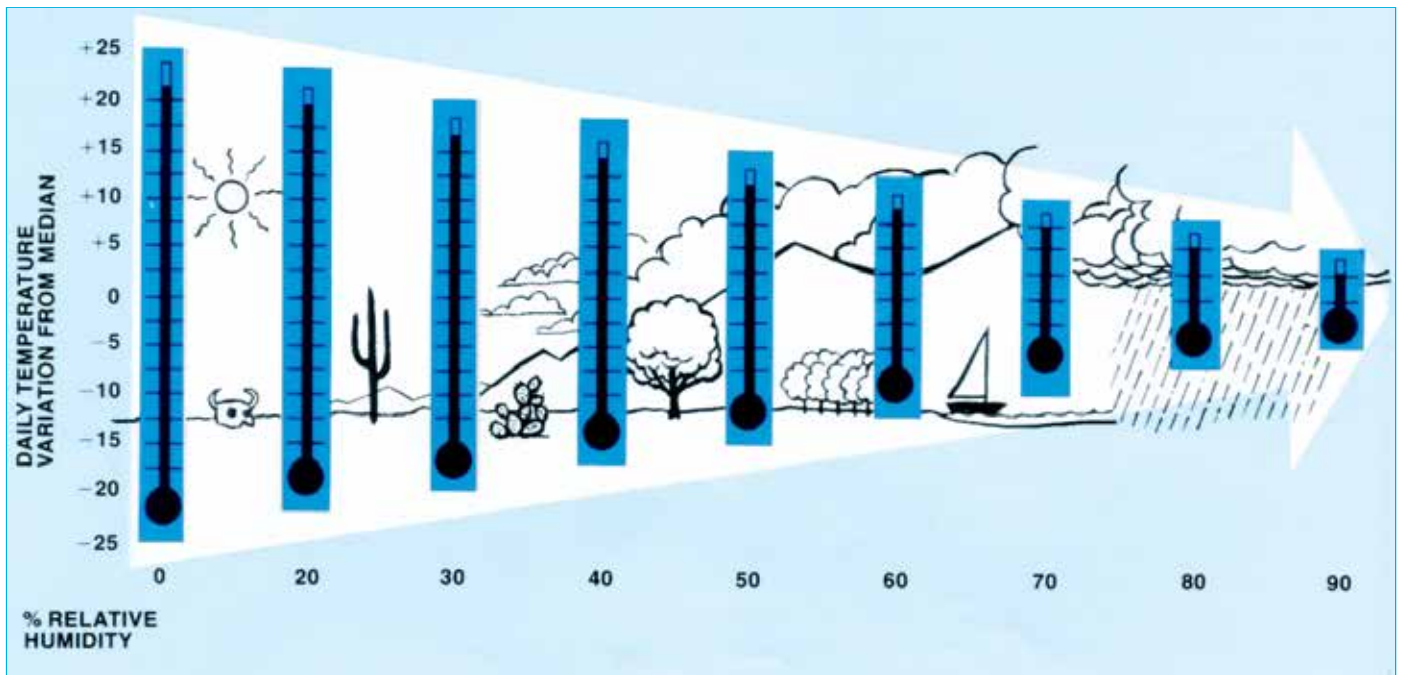

Fig. 3



Breather Valves

AGM CONTAINER CONTROLS, INC.
PO BOX 40020 • TUCSON ARIZONA 85717-0020
TEL: 800-995-5590 (520) 881-2130 • FAX: (520) 881-4983
www.agmcontainer.com • sales@agmcontainer.com

THEORY & CHARACTERISTICS

Therefore, the ideal valve should remain sealed except during airlift or under extreme temperature changes, but when open should have sufficient flow to relieve air pressure as fast as it builds up.

As noted under "Temperature Variation During Storage," it has been shown that valves set as low as +0.5 (pressure) and -0.5 (vacuum) psid will protect against excessive moisture intrusion for years. In order to select a valve which will adequately protect the container against excessive pressure or vacuum, we must know the following:

1. How Much Pressure or Vacuum Can the Container Withstand Without Leaking or Deforming?

This figure will establish the pressure at which the valve must achieve its rated flow, which is measured at 1.5 psi above the reseal setting. If possible, a safety factor should be utilized by setting the required flow pressure slightly below the container's deformation point.

Important: Most containers can withstand more pressure than vacuum. For instance, the container pictured in **Fig. 4** is normally pressurized to 5 psi and can probably withstand an internal pressure of up to 50 psi without deformation. However, it took less than 3 psi of vacuum, resulting from a temperature drop of 90°F during surface transport of this empty, unpressurized container to cause the deformation shown.

For this reason, a pressure setting somewhat higher than the vacuum setting is often specified to provide a sufficient differential without overstressing the container.



Fig. 4 Two views of a collapsed container





Breather Valves

AGM CONTAINER CONTROLS, INC.
PO BOX 40020 • TUCSON ARIZONA 85717-0020
TEL: 800-995-5590 (520) 881-2130 • FAX: (520) 881-4983
www.agmcontainer.com • sales@agmcontainer.com

THEORY & CHARACTERISTICS

However, too great a differential (more than 3 psi) between the pressure and vacuum settings can cause valve design problems and increased cost. If a greater than 3 psi differential is required, 2 one-way valves should be used. It should be remembered that a total differential in sealing pressures of 1 to 2 psi will provide more than adequate moisture protection worldwide.

2. What is the Effective Volume of the Container?

It is essential to know how much air, in cubic feet, will be inside the container. This may be calculated by subtracting the volume of the contents (engine, missile, etc.) from the inside volume of the container.

3. How Rapid a Change in Pressure Might be Encountered?

The highest rate of pressure change will usually occur during the depressurizing and repressurizing of an aircraft's cargo compartment during air transport. According to the International Air Transport Association (IATA) Standard Specification 80/2, "Pressure Equalization Requirements for Aircraft and Shipping Containers (Par. 3.2)," the cargo compartment pressure decreases from standard sea level (14.7 lbs./in.²) to minimum cruise altitude equivalent of 8,500 feet (10.7 lbs./in.²) at a maximum climb rate of 2,500 feet per minute and increases back to sea level at a maximum descent rate of 1,500 feet per minute. IATA also specifies (Par. 6.2.3) that breather valves shall ensure a minimum air flow of 12% per minute of the internal container volume.

A Society of Automotive Engineers (SAE) Specification AS27166* "Valve, Pressure Equalizing, Gaseous Products," also specifies 12% as a minimum flow rate, but subtracts the volume of the material in the container, resulting in the following formula (Par. 3.6.3.1):

$$\text{Minimum Flow Rate (ft.}^3\text{/min.)} = (V_c - V_m) 0.12$$

Where V_c = Volume of container (ft.³)
and V_m = Volume (min.) of material in container (ft.³)

* Replaces cancelled military specification MIL-V-27166.

It should be emphasized that this is a maximum, and would tend to be reduced by other factors, such as temperature change and elasticity of the container, so no additional safety factors need to be added. However, where there is a possibility that an empty container could be transported by air, it might be wise to disregard the displacement of the contents and use the internal volume of the empty container as the basis for calculating flow requirements.

CRACKING PRESSURE

Sometimes we are asked to supply a valve that will "crack" (start to open) at a specified pressure, within a tolerance. While this requirement can be met, it involves additional testing and, therefore, increased cost, and—except under extraordinary circumstances—would appear to be unnecessary, since the settings for seal and design flow provide the desired protection for both container and contents. In addition, SAE Specification AS27166 sets maximum cracking pressure offsets from the reseal pressure.

WHAT ABOUT SAND AND DUST PROTECTION?

SAE Specification AS27166 requires that breather valves must still reseal after being tested for sand and dust protection per MIL-STD-810. The sand used in the test is similar to talcum powder, too fine to affect the sealing surfaces of the valve. However, the specification does not require the valve to keep sand and dust out of the container if it opens during a dust storm. This technicality has made it possible for valves with stamped or wire mesh screens to certify as meeting the specification. **For total sand and dust protection, you need to specify breather valve Series TA330, TA333-R or TA770-R, as these valves have dust baffles and covers that will protect the contents of the container from not only sand and dust, but also wind-driven rain and water from high-pressure decontamination hoses.**

SELECTION AND PART NUMBER DESIGNATION

Now that you have established the design flow rate and the reseal pressure (which is 1.0 to 1.5 psi below the flow rate pressure), you may proceed to actual selection of the breather valve you will need.

The Breather Valve Selection Chart (**Fig. 5**) will give you the flow rates of the various breather valves listed in this catalog, and indicate maximum net volumes of containers they may be used on.



Breather Valves

AGM CONTAINER CONTROLS, INC.
 PO BOX 40020 • TUCSON ARIZONA 85717-0020
 TEL: 800-995-5590 (520) 881-2130 • FAX: (520) 881-4983
 www.agmcontainer.com • sales@agmcontainer.com

THEORY & CHARACTERISTICS

Each breather valve data sheet includes a Part Number Designation Chart which shows how to designate the desired resealing pressures in the part number of the valve. Dimensions, performance characteristics and optional features, such as a manual release button (essential for breaking a vacuum seal) and RFI/EMI shielding, are also indicated.

APPLICABLE SPECIFICATIONS

SAE Specification AS27166, entitled "Valve: Pressure Equalizing, Gaseous Products," details environmental requirements and test procedures for vibration, temperature, salt, fog, sand and dust, rough handling, etc., as well as settings and flow. (Note: Many design activities have found it impractical to use the settings designated in this specification and have called out other settings more suitable for their particular container design.) AGM Breather Valves Series TA238, TA240-R, TA330, TA333-R and TA770-R will meet all requirements of this specification (but see "What About Sand & Dust Protection?" above). AS27166 is also referenced in Department of Defense MIL-STD-648C.

In addition, AGM valves are specified on more than 300 Army, Navy and Air Force drawings.

SPECIAL REQUIREMENTS

If you require identification of AGM valves with a part number other than one shown in this catalog, please contact AGM for part number verification. You should also contact AGM if you plan to put one of AGM's catalog numbers on a document requiring MIL-STD-130 identification.

If you have special requirements which cannot be met by using a standard valve, please contact AGM's design engineering team regarding possible modifications or a special valve design to meet your needs.

MOUNTING

Unless otherwise specified in this catalog, all valves are supplied with a nut, washer and gasket for mounting through a hole on a flat, smooth surface. Valve gaskets may not provide a proper seal if the mounting surface is curved or rough. Valves can also be installed in a mounting flange (See page 20) or a threaded boss when a suitable counterbore has been provided for thread relief.

IMPORTANT: Every AGM breather valve is individually tested and certified for compliance to performance requirements.

BREATHER VALVE SELECTION CHART

VALVE SERIES PART NUMBER	PAGE NO.	FLOW RATE	MAXIMUM NET VOLUME OF CONTAINER **
TA292-R	10 - 11	0.5 scfm†	up to 4 cu.ft.‡
TA294-R	10 - 11	1.0 scfm†	up to 8 cu.ft.‡
TA238	12	4.0 scfm†	up to 33 cu.ft.‡
TA240-R	13	4.0 scfm†	up to 33 cu.ft.‡
TA340-R	14	0.5 - 3.0 scfm*†	up to 25 cu.ft.‡
TA440-R	15	2.0 - 4.0 scfm*†	up to 33 cu.ft.‡
TA330	16 - 17	1.5 - 4.0 scfm*†	up to 33 cu.ft.‡
TA333-R	16 - 17	1.5 - 4.0 scfm*†	up to 33 cu.ft.‡
TA770-R	18 - 19	10 - 25 scfm*†	up to 208 cu.ft.‡

* Depends upon relief setting of valve.
 †To convert to metric equivalent (liters/sec) multiply by 0.472
 ** Based on formula on pg. 6.
 ‡To convert to metric equivalent (m³) multiply by 2.831 x 10⁻²

Fig. 5



Breather Valves

AGM CONTAINER CONTROLS, INC.
PO BOX 40020 • TUCSON ARIZONA 85717-0020
TEL: 800-995-5590 (520) 881-2130 • FAX: (520) 881-4983
www.agmcontainer.com • sales@agmcontainer.com

APPLICATIONS

Shown here are just a few of the many containers currently in use that incorporate AGM Breather Valves, as well as other AGM products (Humidity Indicators, Records Holders, Desiccators and Tie Downs).

AGM Breather Valves have permitted many new and radical container designs, using a variety of materials. Substantial weight and cube reductions have been achieved, resulting in impressive savings in fabrication and shipping costs.

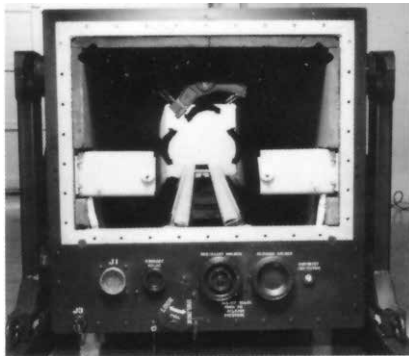

- **PATRIOT SHIPPER/LAUNCHER CANISTER** uses TA770-R Valve; also Desiccant Holder, Records Holder, and Humidity Indicator. (Photos courtesy Lockheed-Martin and U.S. Army.)

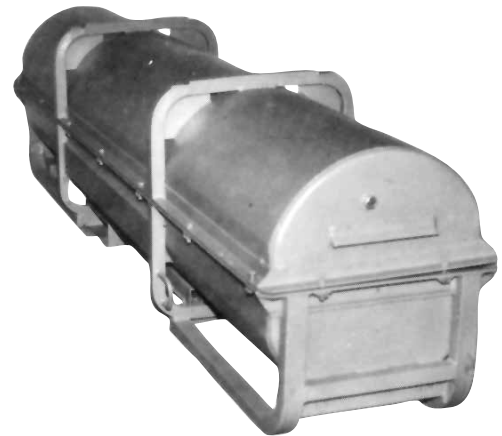

- **HARPOON MISSILE SUSTAINER SECTION CONTAINER** uses TA330 Valve; also Humidity Indicator. (Photo courtesy U.S. Navy.)



- **TRANSIT CASE** uses TA333-R Valve. (Photo courtesy ECS Composites.)



- **"ISOPOD" MAINTENANCE SUPPORT MODULE** uses TA440-R Valve; also Tie Down Straps. (Photo courtesy Raytheon.)

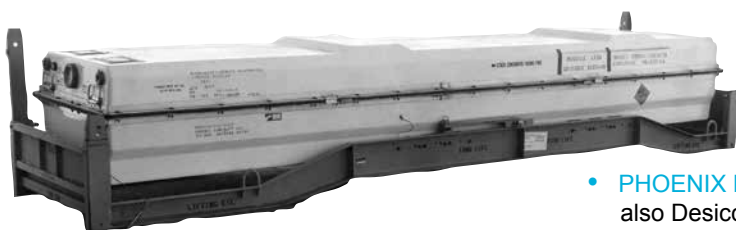

- **PHOENIX MISSILE CONTAINER** uses TA440-R Valve; also Desiccant Port, Records Holder, and Tie Down Straps. (Photo courtesy Raytheon and U.S. Navy.)



Breather Valves

AGM CONTAINER CONTROLS, INC.
PO BOX 40020 • TUCSON ARIZONA 85717-0020
TEL: 800-995-5590 (520) 881-2130 • FAX: (520) 881-4983
www.agmcontainer.com • sales@agmcontainer.com

APPLICATIONS



- **F100 ENGINE CONTAINER** uses TA770-R Valves; also Desiccant Port, Records Holder and Humidity Indicator. (Photo courtesy Plastics Research Corp.)

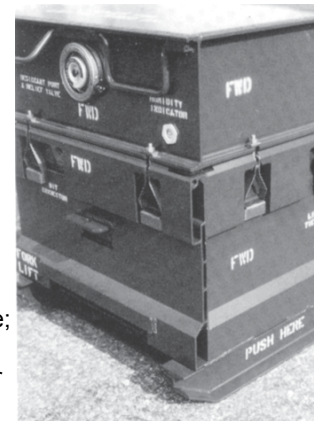

- **TACIT RAINBOW MINIDRONE CONTAINER** uses TA770-R Valve; also Desiccant Port and Humidity Indicator. (Photo courtesy U.S. Air Force.)

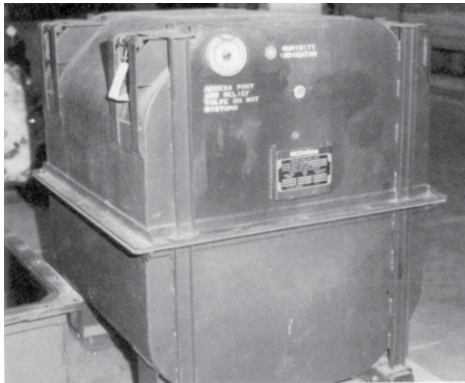

- **PERSONNEL CARRIER ENGINE/ TRANSMISSION CONTAINER** uses TA330 Valve; also Desiccant Port and Humidity Indicator. (Photo courtesy U.S. Army.)

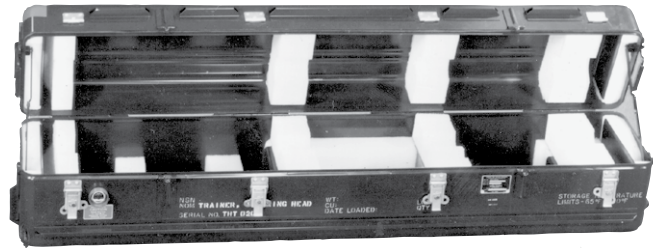

- **STINGER MISSILE CONTAINER** uses TA333-R Valve. (Photo courtesy U.S. Army.)



- **TRANSIT CASE** uses TA238 Valve. (Photo courtesy Zero Corporation.)



- **M16 RIFLE CONTAINER** uses TA333-R Valve; also Humidity Indicator. (Photo courtesy Hardigg Industries Inc.)

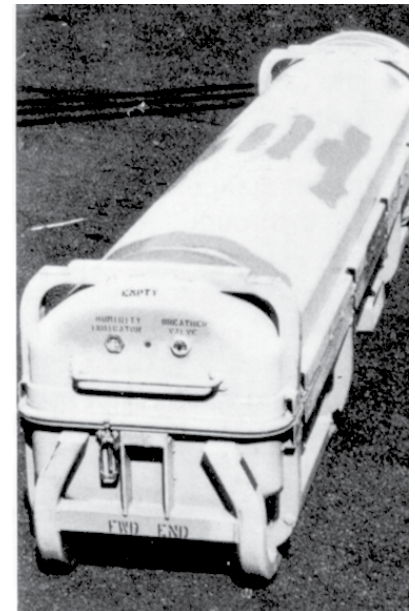

- **MARK 46 TORPEDO CONTAINER** uses TA330 Valve; also Humidity Indicator. (Photo courtesy U.S. Navy.)



Breather Valves

AGM CONTAINER CONTROLS, INC.
PO BOX 40020 • TUCSON ARIZONA 85717-0020
TEL: 800-995-5590 (520) 881-2130 • FAX: (520) 881-4983
www.agmcontainer.com • sales@agmcontainer.com

TA292-R & TA294-R

TWO-WAY PRESSURE AND VACUUM RELIEF BREATHER VALVES



TA292-R



TA294-R

The TA292-R Breather Valve was designed to meet the need for a low cost, two-way valve for use on transit cases and similar applications up to 4 cubic feet in volume. The valve has separate and distinct settings for both pressure and vacuum relief. It has a flow rate of 0.5 scfm at a pressure of 1.5 psi to 2.0 psi above the valve setting. Standard settings range from 0.5 psid to 3.0 psid reseal pressure.

The valve is tamper-proof and requires no field maintenance. Corrosion-resistant materials are used throughout. The valve seal is made of silicone rubber.

Each valve comes complete with a nut and o-ring, and is intended for small cases that require a low profile valve.

A manual release push button is standard on all TA292-R Valves. It is used to equalize pressure or vacuum differentials in order to open the container.

The TA294-R Breather Valve was designed to meet the need for a low cost, two-way valve for use on transit cases and similar applications up to 8 cubic feet in volume. It is similar to the TA292-R Valves, except it is longer and has a flow rate of 1.0 scfm at a pressure of 1.5 psi to 2.0 psi above the valve setting. Standard settings range from 0.5 to 3.0 psid reseal pressure.

The valve is tamper-proof and requires no field maintenance. Corrosion-resistant materials are used throughout. The valve seal is made of silicone rubber.

Each valve comes complete with a nut, washer and gasket.

A manual release push button is standard on all TA294-R Valves. It is used to equalize pressure or vacuum differentials in order to open the container.



Breather Valves

AGM CONTAINER CONTROLS, INC.
 PO BOX 40020 • TUCSON ARIZONA 85717-0020
 TEL: 800-995-5590 (520) 881-2130 • FAX: (520) 881-4983
 www.agmcontainer.com • sales@agmcontainer.com

TA292-R & TA294-R

TA292-R

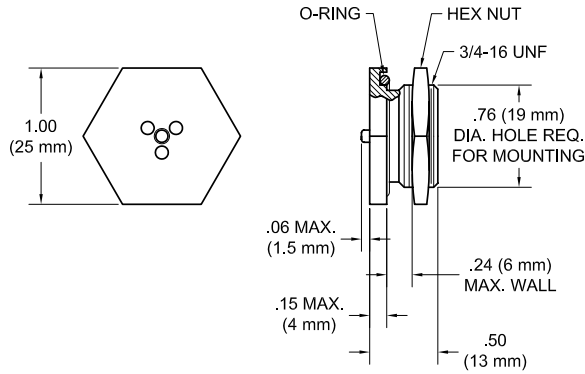

TA294-R

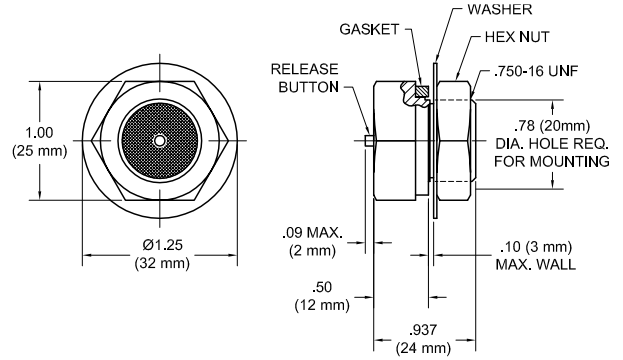

TA292 } - □ - □ R (STANDARD FEATURE: MANUAL RELEASE PUSH BUTTON)
 TA294 }

PRESSURE SIDE (FLOW OUT)				VACUUM SIDE (FLOW IN)			
Dash No.	Sealed @	Flow Rate	@ Pressure	Dash No.	Sealed @	Flow Rate	@ Pressure
		TA292-R	TA294-R			TA292-R	TA294-R
-05	0.5 psid*	0.5 scfm†	1.0 scfm† @ 2.0 psid*	-05	0.5 psid*	0.5 scfm†	1.0 scfm† @ 2.0 psid*
-10	1.0 psid*	0.5 scfm†	1.0 scfm† @ 2.5 psid*	-10	1.0 psid*	0.5 scfm†	1.0 scfm† @ 2.5 psid*
-15	1.5 psid*	0.5 scfm†	1.0 scfm† @ 3.0 psid*	-15	1.5 psid*	0.5 scfm†	1.0 scfm† @ 3.0 psid*
-20	2.0 psid*	0.5 scfm†	1.0 scfm† @ 3.5 psid*	-20	2.0 psid*	0.5 scfm†	1.0 scfm† @ 3.5 psid*
-25	2.5 psid*	0.5 scfm†	1.0 scfm† @ 4.5 psid*	-25	2.5 psid*	0.5 scfm†	1.0 scfm† @ 4.5 psid*
-30	3.0 psid*	0.5 scfm†	1.0 scfm† @ 5.0 psid*	-30	3.0 psid*	0.5 scfm†	1.0 scfm† @ 5.0 psid*

* To convert to metric equivalent (millibars) multiply by 69.

† To convert to metric equivalent (liters/sec) multiply by 0.472.

Dash numbers for the Pressure and Vacuum sides may be used in any combination (i.e., TA294-05-15-R). Before making drawings of these valves, contact AGM for part numbers to be used.

TA292-R

Materials & Finish

Housing and hex nut are aluminum alloys. Standard finish is black anodize. O-ring is per MS28775-018.

Weight

0.02 lbs. (8.4 grams)

Mounting Requirements: Each valve comes complete with a nut and an o-ring.

Mounting hole diameter: 0.76 ± 0.010 (19.3 ± 0.2 mm)

Installation torque: 25-35 in. - lbs. (3.0-4.0 N•m)

Maximum wall thickness: 0.24 (6 mm)

Add washer for wall thickness less than: 0.05 (1.3 mm). (AGM P/N 196284, order separately.)

For threaded boss installation: 0.750-16 UNF-3B; no counterbore requirement.

TA294-R

Materials & Finish

Housing, hex nut and washer are aluminum alloys. Standard finish is alodine, except for the hexnut, which is anodized. Gasket material is per AMS-R-6855, Class II, Grade 60.

Weight

0.02 lbs. (32 grams)

Mounting Requirements: Each valve comes complete with a nut, washer and gasket.

Mounting hole diameter: 0.78 ± 0.015 (20 ± 0.4 mm)

Installation torque: 25-35 in. - lbs. (3.0-4.0 N•m)

Maximum wall thickness: 0.10 (3 mm)

Minimum wall thickness: 0

For threaded boss installation: 0.750-16 UNF-2B; no counterbore requirement.



Breather Valves

AGM CONTAINER CONTROLS, INC.
 PO BOX 40020 • TUCSON ARIZONA 85717-0020
 TEL: 800-995-5590 (520) 881-2130 • FAX: (520) 881-4983
 www.agmcontainer.com • sales@agmcontainer.com

TA238

TWO-WAY PRESSURE AND VACUUM RELIEF VALVE WITH RECESSED MANUAL RELEASE PUSH BUTTON

MEETS SAE SPECIFICATION AS27166 & MIL-DTL-27166



**TA238
BREATHER VALVE**

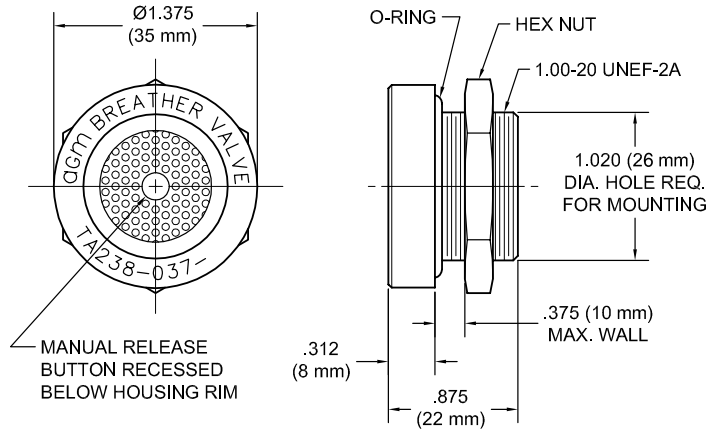

The TA238 Breather Valve fills the need for a low cost, but higher flow valve than the TA294-R. The valve can be used on transit cases and similar applications up to 33 cubic feet in volume. It has a flow rate of 4.0 scfm and is available in settings from 0.5 psid to 5.0 psid.

The valve is lightweight, rugged, tamper-proof and requires no field maintenance. Corrosion-resistant materials are used throughout. The valve seal is made of silicone rubber.

A recessed manual release push button is standard on all TA238 Valves. It is used to equalize

residual pressure or vacuum differentials in order to open the container.

The valve will not provide protection against water intrusion from a high-pressure hose down. Use a TA330, TA333 or TA770 Breather Valve for applications where this is required.

The valve is identical in dimensions, materials and performance to the Zero ZSP6-037 Breather Valve.

An o-ring gasket and hex nut are provided with each valve. RFI/EMI shielding is available.

Part No.	V	P	Vacuum (PSID)* Cracking		Reseal	Pressure (PSID)* Cracking			Flow Rate 4 SCFM† @ PSID*	
			Max.	Min.		Max.	Min.	Reseal	Vacuum	Pressure
TA238-037-1	.5	.5	.8	.4	.2	.8	.4	.2	1.50	1.50
TA238-037-3	1.5	1.5	1.9	1.0	.8	1.9	1.0	.8	2.90	2.90
TA238-037-4	3.5	2.5	4.0	2.4	2.0	3.0	1.7	1.4	5.10	5.00
TA238-037-6	.5	2.5	.8	.4	.2	3.0	1.7	1.4	1.50	5.00

* To convert to metric equivalent (millibars) multiply by 69.

† To convert to metric equivalent (liters/sec) multiply by 0.472.

AGM can also supply TA238 Valves with other settings than those shown above. Please contact AGM for availability. Before making drawings of these valves, contact AGM for part numbers to be used.

Weight

TA2380.065 lbs.
30 grams

Materials & Finish

Housing and hex nut are aluminum with black anodize finish. O-ring is per MS28775-120.

Mounting Requirements:

An o-ring and a hex nut are provided with each valve.
 Mounting hole diameter: 1.020 ± 0.015 (26 ± 0.38 mm)
 Installation torque: 30-40 in. - lbs. (3.4-4.5 N·m)
 Maximum wall thickness: 0.375 (10 mm)
 Add washer(s) for wall thickness less than 0.110 (3 mm). (AGM P/N 300013-16, order separately.)
 For threaded boss installation: 1.00-20 UNEF-2B; 1.020 ± 0.015 (26 ± 0.38 mm) diameter X 0.110 (3 mm) minimum deep counterbore required for thread relief.



Breather Valves

AGM CONTAINER CONTROLS, INC.
 PO BOX 40020 • TUCSON ARIZONA 85717-0020
 TEL: 800-995-5590 (520) 881-2130 • FAX: (520) 881-4983
 www.agmcontainer.com • sales@agmcontainer.com

TA240-R

TWO-WAY PRESSURE AND VACUUM RELIEF VALVE WITH RECESSED MANUAL RELEASE PUSH BUTTON

MEETS SAE SPECIFICATION AS27166 & MIL-DTL-27166

NEW!



TA240-R
BREATHER VALVE

The TA240-R is a hybrid of the TA333-R and TA238 valves. It combines the mounting thread size and hex shape of our TA333-R with the screened cover and lower cost of our TA238. The valve can be used on transit cases and similar applications up to 33 cubic feet in volume. It has a flow rate of 1.5 to 4.0 scfm at 1.5 psid above the reseal point and is available in settings from 0.5 psid to 5.0 psid.

The valve is lightweight, rugged, tamper-proof and requires no field maintenance. Corrosion-resistant materials are used throughout. The valve seal is made of silicone rubber.

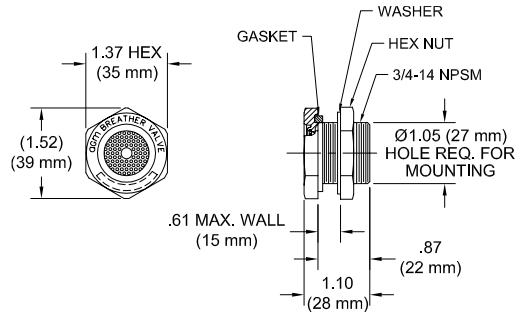

A recessed manual release push button is standard on all TA240-R Valves. It is used to equalize residual pressure or vacuum differentials in order to open the container.

The valve will not provide protection against water intrusion from a high-pressure hose down. Use a TA330, TA333 or TA770 Breather Valve for applications where this is required.

Gasket, washer and hex nut are provided with each valve. A mounting flange and RFI/EMI shielding are available for this valve (see page 20).

As indicated in the table below, the lower the setting, the higher the flow rate.

TA240 - □ - □ - R (STANDARD FEATURE: MANUAL RELEASE PUSH BUTTON)

PRESSURE SIDE (FLOW OUT)			VACUUM SIDE (FLOW IN)		
Dash No.	Sealed @	Flow Rate @ Pressure	Dash No.	Sealed @	Flow Rate @ Pressure
-05	0.5 psid*	4.0 scfm† @ 2.0 psid*	-05	0.5 psid*	4.0 scfm† @ 2.0 psid*
-10	1.0 psid*	3.5 scfm† @ 2.5 psid*	-10	1.0 psid*	3.5 scfm† @ 2.5 psid*
-15	1.5 psid*	3.0 scfm† @ 3.0 psid*	-15	1.5 psid*	3.0 scfm† @ 3.0 psid*
-20	2.0 psid*	2.5 scfm† @ 3.5 psid*	-20	2.0 psid*	2.5 scfm† @ 3.5 psid*
-25	2.5 psid*	1.5 scfm† @ 4.0 psid*	-25	2.5 psid*	1.5 scfm† @ 4.0 psid*

* To convert to metric equivalent (millibars) multiply by 69.

† To convert to metric equivalent (liters/sec) multiply by 0.472.

Dash numbers for the Pressure and Vacuum sides may be used in any combination (i.e., TA240-05-15-R)

AGM can also supply TA240-R Valves with other settings than those shown above. Please contact AGM for availability. Before making drawings of these valves, contact AGM for part numbers to be used.

Weight

0.08 lbs. (36 grams)

Materials & Finish

Housing, washer and hex nut are aluminum alloy. Housing is black anodize finish. Washer and nut are clear anodize finish. Other finishes available upon request. Gasket is silicone rubber per ZZ-R-765. Torque value for installation: 30 in. - lbs. (3.4 N•m)

Mounting Requirements:

Gasket, washer and hex nut are provided with each valve. Mounting hole diameter: 1.05 ± 0.015 (27 ± 0.38 mm)

Installation torque: 30-40 in. - lbs. (3.4-4.5 N•m)

Maximum wall thickness: 0.61 (15 mm)

Add extra washer for wall thickness less than 0.04 (1 mm). (AGM P/N 300013-16, order separately.)

For threaded boss installation: 3/4-14 NPSM; 1.05 ± 0.015 (27 ± 0.38 mm) X 0.08 (2 mm) minimum deep counterbore required for thread relief.



Breather Valves

AGM CONTAINER CONTROLS, INC.
 PO BOX 40020 • TUCSON ARIZONA 85717-0020
 TEL: 800-995-5590 (520) 881-2130 • FAX: (520) 881-4983
 www.agmcontainer.com • sales@agmcontainer.com

HUMI-VALVE® TA340-R

COMBINATION BREATHER VALVE AND HUMIDITY INDICATOR

NEW!



TA340-R

The TA340-R HUMI-VALVE® is a new design, incorporating a humidity indicator* and a two-way breather valve all in the same aluminum housing, thereby saving space and the cost of an additional hole in the case. The valve has separate and distinct settings for both pressure and vacuum relief. It has a flow rate of 0.5 to 3.0 scfm at 1.5 psid above the valve setting. Standard settings are from 0.5 psid to 3.0 psid reseal pressure. The lower the setting, the higher the flow rate, making this valve suitable for transit cases and similar applications up to 25 cubic feet in volume.

Designed to accept a replaceable desiccant cartridge, this valve will mate with the 658800 mounting flange (see page 20) for ease of desiccant replacement. Desiccant cartridges are available in lengths up to six inches and hold approximately 6.5 grams (0.23 ounces) per inch of cartridge. There is a separate air path to the humidity

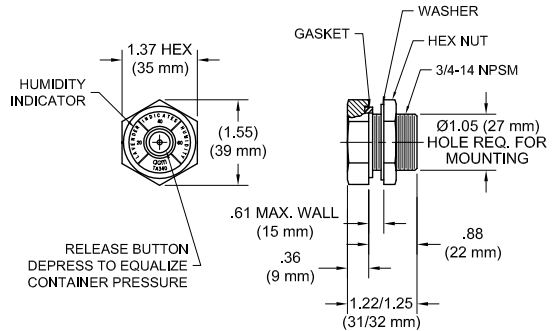

indicator, bypassing the desiccant cartridge. **IMPORTANT:** The installation of the desiccant cartridge will reduce the available flow rate for a given pressure setting. The TA340-R can also be supplied in RF/EMI shielded versions.

The TA340-R is lightweight, rugged, tamper-proof and requires no field maintenance. Corrosion-resistant materials are used throughout. The valve seal is made of silicone rubber.

A manual release push button is standard on all TA340-R valves. It is used to equalize residual pressure or vacuum differentials in order to make opening the container easier.

Gasket, washer and hex nut are provided with each valve.

* Humidity indicator is not separately replaceable.

TA340-□-□-R (STANDARD FEATURE: MANUAL RELEASE PUSH BUTTON)

PRESSURE SIDE (FLOW OUT)			VACUUM SIDE (FLOW IN)		
Dash No.	Sealed @	Flow Rate @ Pressure	Dash No.	Sealed @	Flow Rate @ Pressure
-05	0.5 psid*	2.0 scfm† @ 2.0 psid*	-05	0.5 psid*	2.0 scfm† @ 2.0 psid*
-10	1.0 psid*	1.5 scfm† @ 2.5 psid*	-10	1.0 psid*	3.0 scfm† @ 2.5 psid*
-15	1.5 psid*	1.5 scfm† @ 3.0 psid*	-15	1.5 psid*	2.5 scfm† @ 3.0 psid*
-20	2.0 psid*	1.0 scfm† @ 3.5 psid*	-20	2.0 psid*	2.5 scfm† @ 3.5 psid*
-25	2.5 psid*	1.0 scfm† @ 4.0 psid*	-25	2.5 psid*	2.0 scfm† @ 4.0 psid*
-30	3.0 psid*	0.5 scfm† @ 4.5 psid*	-30	3.0 psid*	2.0 scfm† @ 4.5 psid*

* To convert to metric equivalent (millibars) multiply by 69.

† To convert to metric equivalent (liters/sec) multiply by 0.472.

Dash numbers for the Pressure and Vacuum sides may be used in any combination (i.e., TA340-05-15-R)

AGM can also supply TA340-R Valves with other settings than those shown above. Please contact AGM for availability.

Before making drawings of these valves, contact AGM for part numbers to be used.

Weight

0.09 lbs. (40 grams)

Materials & Finish

Housing, nut and washer are aluminum alloy with clear anodize finish. Gasket is silicone rubber per ZZ-R-765. Window is high strength plastic.

Mounting Requirements: Gasket, washer and hex nut are provided with each valve.

Mounting hole diameter: 1.05 ± 0.015 (27 ± 0.38 mm)

Installation torque: 30-40 in. - lbs. (3.4-4.5 N•m)

Maximum wall thickness: 0.61 (15 mm)

Add extra washer for wall thickness less than 0.025 (0.64 mm). (AGM P/N 300013-16, order separately.)

For threaded boss installation: 3/4-14 NPSM; no counterbore requirement.



Breather Valves

AGM CONTAINER CONTROLS, INC.
 PO BOX 40020 • TUCSON ARIZONA 85717-0020
 TEL: 800-995-5590 (520) 881-2130 • FAX: (520) 881-4983
 www.agmcontainer.com • sales@agmcontainer.com

HUMI-VALVE® TA440-R

COMBINATION BREATHER VALVE AND HUMIDITY INDICATOR



TA440-R

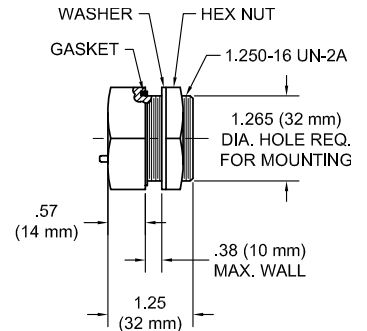
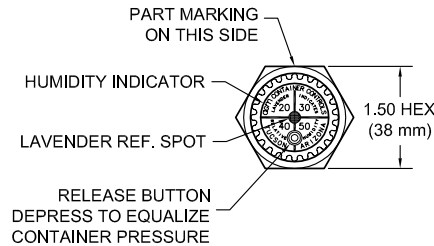

The TA440-R HUMI-VALVE® incorporates a humidity indicator and a two-way breather valve all in the same housing, thereby saving the cost of an additional hole in the case. The valve has separate and distinct settings for both pressure and vacuum relief. It has a flow rate of 4.0 scfm at 1.5 psi above the valve setting. Standard settings are from 0.5 psid to 3.0 psid reseal pressure. The lower the setting, the higher the flow rate, making this valve suitable for transit cases and similar applications up to 33 cubic feet in volume.

There is a separate path to the humidity indicator.

The TA440-R is lightweight, rugged, tamper-proof and requires no field maintenance. Corrosion-resistant materials are used throughout. The valve seals are made of silicone rubber.

A manual release push button is standard on all TA440-R Valves. It is used to equalize residual pressure or vacuum differentials in order to make opening the container easier.

Gasket, washer and hex nut are provided with each valve.

TA440 - □ - □ - R (STANDARD FEATURE: MANUAL RELEASE BUTTON)

PRESSURE SIDE (FLOW OUT)			VACUUM SIDE (FLOW IN)		
Dash No.	Sealed @	Flow Rate @ Pressure	Dash No.	Sealed @	Flow Rate @ Pressure
-05	0.5 psid*	4.0 scfm † @ 2.0 psid*	-05	0.5 psid*	4.0 scfm † @ 2.0 psid*
-10	1.0 psid*	4.0 scfm † @ 2.5 psid*	-10	1.0 psid*	4.0 scfm † @ 2.5 psid*
-15	1.5 psid*	3.5 scfm † @ 3.0 psid*	-15	1.5 psid*	3.5 scfm † @ 3.0 psid*
-20	2.0 psid*	3.0 scfm † @ 3.5 psid*	-20	2.0 psid*	3.0 scfm † @ 3.5 psid*
-25	2.5 psid*	2.5 scfm † @ 4.0 psid*	-25	2.5 psid*	2.5 scfm † @ 4.0 psid*
-30	3.0 psid*	2.0 scfm † @ 4.5 psid*	-30	3.0 psid*	2.0 scfm † @ 4.5 psid*

* To convert to metric equivalent (millibars) multiply by 69.

† To convert to metric equivalent (liters/sec) multiply by .0472.

Dash numbers for the Pressure and Vacuum sides may be used in any combination (i.e., TA440-05-15-R).

AGM can also supply TA440-R Valves with other settings than those shown above. Please contact AGM for availability.

Before making drawings of these valves, contact AGM for part numbers to be used.

Weight

0.075 lbs. (34 grams)

Materials & Finish

Body and hex nut are black polycarbonate plastic. Washer is aluminum alloy. Humidity Indicator housing is high strength clear plastic. Gasket material is per AMS-R-6855, Class II, Grade 60.

Mounting Requirements: A gasket, washer and hex nut are provided with each valve.
 Mounting hole diameter: 1.265 ± 0.015 (32 ± 0.3 mm)
 Installation torque: 30-40 in. - lbs. (3.4-4.5 N·m)
 Maximum wall thickness: 0.38 (10 mm)
 Minimum wall thickness: 0
 For threaded boss installation: 1.250-16 UN-2B; no counterbore requirement.



Breather Valves

AGM CONTAINER CONTROLS, INC.
PO BOX 40020 • TUCSON ARIZONA 85717-0020
TEL: 800-995-5590 (520) 881-2130 • FAX: (520) 881-4983
www.agmcontainer.com • sales@agmcontainer.com

TA333-R & TA330

TWO-WAY PRESSURE AND VACUUM RELIEF VALVES WITH OPTIONAL RECESSED MANUAL RELEASE PUSH BUTTON

MEETS SAE SPECIFICATION AS27166 & MIL-DTL-27166



TA333-R
TWO-WAY VALVE WITH RECESSED MANUAL RELEASE



TA330
TWO-WAY VALVE

The TA333-R Breather Valve has separate and distinct settings for both pressure and vacuum relief. It has a flow rate that ranges from 1.5 to 4.0 scfm at 1.5 psi above the valve reseal setting, making it suitable for containers and similar applications up to 33 cubic feet in volume. Standard settings are available from 0.5 psid to 3.0 psid reseal pressure. The lower the setting, the higher the flow rate.

The valve is tamper-proof and requires no field maintenance. Corrosion-resistant materials are used throughout. The valve seal is made of silicone rubber. The spherical valve seat is Teflon coated for easy "break-away" action even after prolonged storage.

The manual release push button is used to equalize the pressure or vacuum differentials in order to make opening the container easier. The button is recessed in the cover to protect it from damage and eliminate the possibility that an adjacent container might press the button and inadvertently cause the valve to remain open. A unique feature of the push button is a light duty spring under the cover, separating the button from the vacuum stem, which must be overcome before the button opens the valve.

Gasket, washer and hex nut for mounting are provided with each valve. A weldable nut is available for use as a threaded boss, or the valve may be used with our 658800 mounting flange (see page 20). RFI/EMI shielding is also available.

The TA330 Breather Valve has the same performance characteristics as the TA333-R, except it does not have a manual release push button. It is ideal for pressure relief only applications or situations where a manual release feature is not wanted. The TA330 has separate and distinct settings for both pressure and vacuum relief. It has a flow rate of 1.5 to 4.0 scfm at 1.5 psi above the valve reseal setting. Standard settings range from 0.5 psid to 3.0 psid reseal pressure. The lower the setting, the higher the flow rate.

The valve is tamper-proof and requires no field maintenance. Corrosion-resistant materials are used throughout. The valve seal is made of silicone rubber. The spherical valve seat is Teflon coated for easy "break-away" action even after prolonged storage.

Gasket, washer and hex nut for mounting are provided with each valve. A weldable nut is available for use as a threaded boss, or the valve may be used with our 658800 mounting flange (see page 20). RFI/EMI shielding is also available.

The TA330 & TA333 Breather Valves' unique cover and dust baffle provides superior protection from sand and dust intrusion. Additionally, the cover makes these valves well suited for high-pressure hose down applications. When compared to a screened valve such as AGM's TA238 Breather Valve as well as competitors' valves, the TA330 & TA333 Breather Valves allow virtually no water to pass when subjected to a high-pressure water stream. The TA330 & TA333 Breather Valves have been tested to the NEMA 250 5.7 high-pressure hose down test; contact AGM's Engineering department for more information.

(See "What About Sand and Dust Protection?" page 6.)



Breather Valves

AGM CONTAINER CONTROLS, INC.
 PO BOX 40020 • TUCSON ARIZONA 85717-0020
 TEL: 800-995-5590 (520) 881-2130 • FAX: (520) 881-4983
 www.agmcontainer.com • sales@agmcontainer.com

TA333-R & TA330

TA333-R

Weight
 0.10 lbs.
 (45 grams)

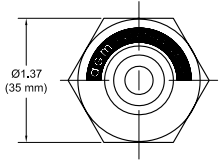

TA333-R
 TWO-WAY VALVE WITH
 RECESSED TYPE "R" BUTTON

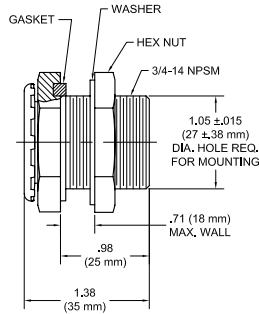

TA330

Weight
 0.10 lbs.
 (45 grams)

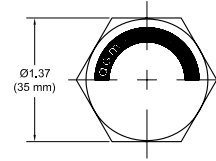

TA330
 STANDARD TWO-WAY
 BREATHER VALVE

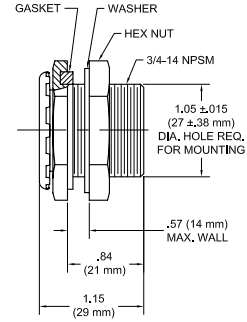

TA333 - □ - □ - R (STANDARD FEATURE: MANUAL RELEASE PUSH BUTTON)

TA330 - □ - □

PRESSURE SIDE (FLOW OUT)			VACUUM SIDE (FLOW IN)		
Dash No.	Sealed @	Flow Rate @ Pressure	Dash No.	Sealed @	Flow Rate @ Pressure
-05	0.5 psid*	3.0 scfm† @ 2.0 psid*	-05	0.5 psid*	4.0 scfm† @ 2.0 psid*
-10	1.0 psid*	2.5 scfm† @ 2.5 psid*	-10	1.0 psid*	3.5 scfm† @ 2.5 psid*
-15	1.5 psid*	2.0 scfm† @ 3.0 psid*	-15	1.5 psid*	3.0 scfm† @ 3.0 psid*
-20	2.0 psid*	2.0 scfm† @ 3.5 psid*	-20	2.0 psid*	3.0 scfm† @ 3.5 psid*
-25	2.5 psid*	1.5 scfm† @ 4.0 psid*	-25	2.5 psid*	2.5 scfm† @ 4.0 psid*
-30	3.0 psid*	1.5 scfm† @ 4.5 psid*	-30	3.0 psid*	2.5 scfm† @ 4.5 psid*

* To convert to metric equivalent (millibars) multiply by 69.

† To convert to metric equivalent (liters/sec) multiply by 0.472.

Dash numbers for the Pressure and Vacuum sides may be used in any combination (i.e., TA333-05-15-R).

AGM can also supply TA333-R & TA330 Valves with other settings than those shown above.

Please contact AGM for availability. Before making drawings of these valves, contact AGM for part numbers to be used.

TA333-R

Mounting Requirements: Gasket, washer and hex nut for mounting are provided with each valve. A weldable nut is available for use as a threaded boss, or the valve may be used with our 658800 Mounting Flange.

Mounting hole diameter: 1.05 ± 0.015 (27 ± 0.38 mm)

Installation torque: 30-40 in. - lbs. (3.4-4.5 N·m)

Maximum wall thickness: 0.57 (14 mm)

Add extra washer for wall thickness less than 0.063 (2 mm). (AGM P/N 300013-16, order separately.)

For threaded boss installation: 3/4-14 NPSM; 1.05 ± 0.015 (27 ± 0.38 mm) diameter X 0.11 (3 mm) minimum deep counterbore required for thread relief.

TA330

Mounting Requirements: Gasket, washer and hex nut are provided with each valve. A weldable nut is available for use as a threaded boss, or the valve may be used with our 658800 Mounting Flange.

Mounting hole diameter: 1.05 ± 0.015 (27 ± 0.38 mm)

Installation torque: 30-40 in. - lbs. (3.4-4.5 N·m)

Maximum wall thickness: 0.71 (18 mm)

Add extra washer(s) for wall thickness less than .063 (2 mm). (AGM P/N 300013-16, order separately.)

For threaded boss installation: 3/4-14 NPSM; 1.05 ± 0.015 (27 ± 0.38 mm) diameter X 0.11 (3 mm) minimum deep counterbore required for thread relief.

Materials & Finish

Housing, nut and washer are aluminum with anodized finish. Gasket is per ZZ-R-765



Breather Valves

AGM CONTAINER CONTROLS, INC.
PO BOX 40020 • TUCSON ARIZONA 85717-0020
TEL: 800-995-5590 (520) 881-2130 • FAX: (520) 881-4983
www.agmcontainer.com • sales@agmcontainer.com

TA770-R

TWO-WAY PRESSURE AND VACUUM RELIEF VALVE WITH HIGH FLOW AND MANUAL RELEASE PUSH BUTTON



MEETS SAE SPECIFICATION AS27166 & MIL-DTL-27166

The TA770-R Breather Valve has separate and distinct settings for both pressure and vacuum relief. It has a flow rate of 10.0 to 25.0 scfm at 1.5 psi above the valve reseal setting, making it suitable for large containers and similar applications up to 208 cubic feet in volume. Standard settings range from 0.5 psid to 3.0 psid reseal pressure. The lower the setting, the higher the flow rate.

The valve is tamper-proof and requires no field maintenance. Corrosion-resistant materials are used throughout. The valve seal is made of silicone rubber.

The spherical valve seat is Teflon coated for easy "break-away" action even after prolonged storage.

The manual release push button is used to equalize the pressure or vacuum differentials in order to make opening the container easier. The button is recessed in the cover to protect it from damage and eliminate the possibility that an adjacent container might press the button and inadvertently cause the valve to remain open. A unique feature of the push button is a light duty spring under the cover, separating the button from the vacuum stem, which must be overcome before the button opens the valve.

Gasket, washer and hex nut for mounting are provided with each valve. RFI/EMI shielding is also available.

The TA770 Breather Valve's unique cover and dust baffle provides superior protection from sand and dust intrusion. Additionally, the cover makes this valve well suited for high-pressure hose down applications. When compared to a screened valve such as AGM's TA238 Breather Valve as well as competitors' valves, the TA770 Breather Valve allows virtually no water to pass when subjected to a high-pressure water stream. The TA770 Breather Valve has been tested to the NEMA 250 5.7 high-pressure hose down test; contact AGM's Engineering department for more information.

(See "What About Sand and Dust Protection?" page 6.)



Breather Valves

AGM CONTAINER CONTROLS, INC.
 PO BOX 40020 • TUCSON ARIZONA 85717-0020
 TEL: 800-995-5590 (520) 881-2130 • FAX: (520) 881-4983
 www.agmcontainer.com • sales@agmcontainer.com

TA770-R

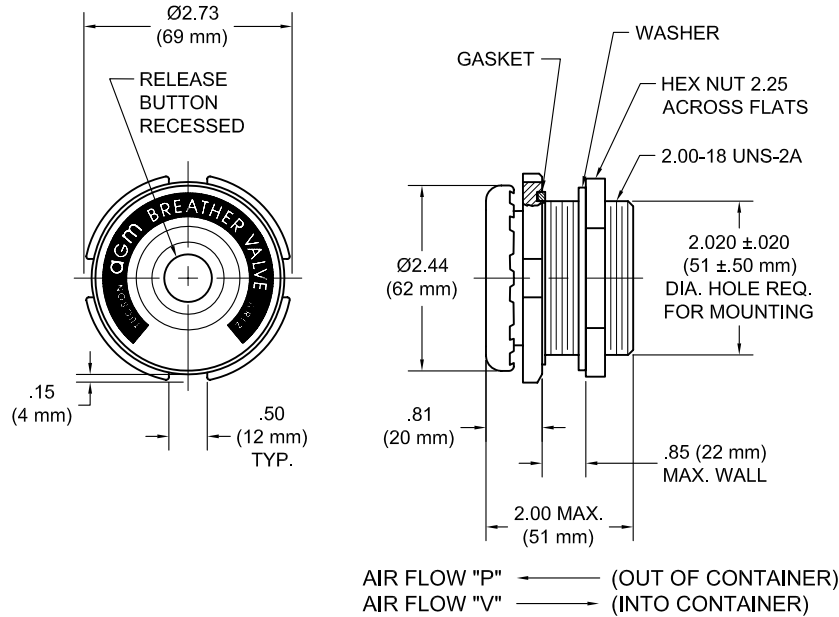

- TA770 □ □ ■ R (STANDARD FEATURE: MANUAL RELEASE PUSH BUTTON)

PRESSURE SIDE (FLOW OUT)			VACUUM SIDE (FLOW IN)		
Dash No.	Sealed @	Flow Rate @ Pressure	Dash No.	Sealed @	Flow Rate @ Pressure
-05	0.5 psid*	20 scfm† @ 2.0 psid*	-05	0.5 psid*	25 scfm† @ 2.0 psid*
-10	1.0 psid*	18 scfm† @ 2.5 psid*	-10	1.0 psid*	23 scfm† @ 2.5 psid*
-15	1.5 psid*	16 scfm† @ 3.0 psid*	-15	1.5 psid*	21 scfm† @ 3.0 psid*
-20	2.0 psid*	14 scfm† @ 3.5 psid*	-20	2.0 psid*	19 scfm† @ 3.5 psid*
-25	2.5 psid*	12 scfm† @ 4.0 psid*	-25	2.5 psid*	17 scfm† @ 4.0 psid*
-30	3.0 psid*	10 scfm† @ 4.5 psid*	-30	3.0 psid*	15 scfm† @ 4.5 psid*

* To convert to metric equivalent (millibars) multiply by 69.
 † To convert to metric equivalent (liters/sec) multiply by 0.472.

Dash numbers for the Pressure and Vacuum sides may be used in any combination (i.e., TA770-05-15-R).

AGM can also supply TA770-R valves with other settings than those shown above. Please contact AGM for availability. Before making drawings of these valves, contact AGM for part numbers to be used.

Weight

0.40 lbs. (181 grams)

Materials & Finish

Housing, nut and washer are aluminum. Housing and nut are anodized and washer is alodine conversion-coated. Gasket is per ZZ-R-765, Class II, Grade 60.

Mounting Requirements: A gasket, washer and hex nut for mounting are provided with each valve.

Mounting hole diameter: 2.020 ± 0.020 (51 \pm 0.50 mm)

Installation torque: 80-90 in. - lbs. (9.0-10.0 N•m)

Maximum wall thickness: 0.85 (22 mm)

Minimum wall thickness: 0.001 (.03 mm)

For threaded boss installation: 2.00-18 UNS-2B; 2.020 ± 0.020 (51 \pm 0.50 mm) diameter X 0.085 (2 mm) minimum deep counterbore required for thread relief.



Breather Valves

AGM CONTAINER CONTROLS, INC.
PO BOX 40020 • TUCSON ARIZONA 85717-0020
TEL: 800-995-5590 (520) 881-2130 • FAX: (520) 881-4983
www.agmcontainer.com • sales@agmcontainer.com

333006 & 658800

RFI/EMI SHIELDED NUT ASSEMBLY

NEW!

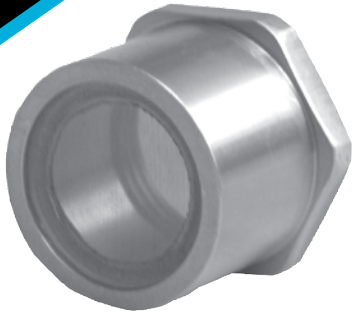

333006

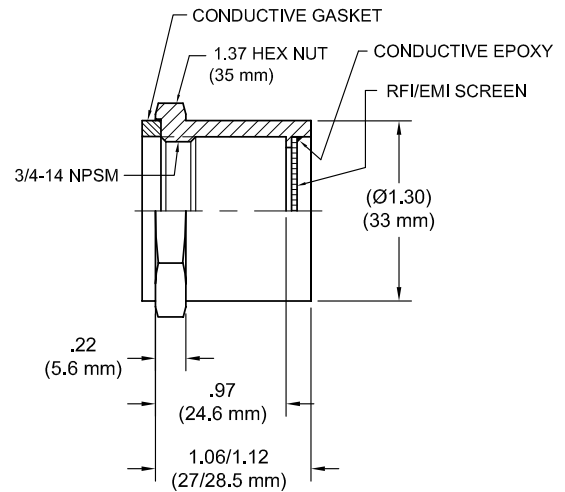

The 333006 Shielded Nut Assembly is intended to provide RFI/EMI shielding on the inside of the housing. Air which passes through the valve also passes through a 100 by 100 mesh Type 304 stainless steel cloth. This cloth, when joined to the MIL-C-5541 Class 3 conversion coated aluminum body with silver-filled conductive epoxy, forms a faraday cage which protects the interior of the container from unwanted radio frequency and electromagnetic radiation.

The 333006 comes standard with a silicone base conductive gasket*, which is filled with silver-coated aluminum particles. In order to make the conductive path complete, the interior surface of the case, which the conductive gasket touches, must also be conductive.

Custom RFI/EMI Shielded Nut assemblies are also available for: the TA770-R family of valves; the 658800 Mounting Flange (shown below); valves with desiccant cartridges installed; and higher attenuation requirements using honeycombed aluminum or drilled holes.

* Conductive gaskets utilizing other base materials are available upon request.

MOUNTING FLANGE

NEW!



658800

The 658800 Mounting Flange provides ease of use and design flexibility. It allows removal of desiccators, breather valves and humidity indicators with a 3/4-14 straight pipe external thread without opening the container.

It also eliminates the need for a threaded boss to be provided in the container. The flange is installed by making a 1.265" diameter hole in the container and securing it into the mounting hole with the provided nut.

The flange and nut have a corrosion-resisting clear anodize finish. A neoprene synthetic rubber environmental gasket is included. Other finishes, gasket materials and RFI/EMI Shielding are available upon request to meet specific needs.

Mounting Requirements: Each flange comes complete with nut, washer, and gasket.

Mounting hole diameter: 1.265 ± 0.015 (32 ± 0.25 mm)

Installation torque: 70-80 in. - lbs. (8.0-9.0 N•m)

Maximum wall thickness: 0.18 (4.5 mm)

Add extra washer for wall thickness less than 0.054 (1.4 mm). (AGM P/N 440009-16, order separately.)



Breather Valves

AGM CONTAINER CONTROLS, INC.
 PO BOX 40020 • TUCSON ARIZONA 85717-0020
 TEL: 800-995-5590 (520) 881-2130 • FAX: (520) 881-4983
 www.agmcontainer.com • sales@agmcontainer.com

MANUAL RELIEF & FILLER VALVES

These manual relief valves are designed for use in small containers or cases, where automatic breathing valves are not required. They provide various methods of manually equalizing pressure or vacuum differentials before opening the containers. Each type is easily installed through a single hole in the wall of the case and comes complete with all attaching hardware. Some have safety wire protection features to prevent unauthorized opening of the valves.

Note: Because it is visually impossible to tell whether the TA321 and TA327 are open or closed, careful consideration should be taken of the potential consequences (continuous exposure to outside atmosphere if left open; potential damage to container if left closed) before selecting these valves.

TA316

Weight: 0.046 lbs.
21 grams
Housing: Aluminum
Finish: Anodize

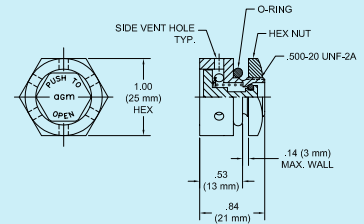
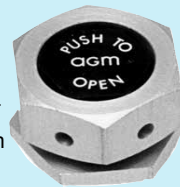

A "push-to-open" valve that is similar in construction to and mounts in the same hole as the TA327 (shown below). Side venting design permits pressure equalization even when button is depressed by personnel wearing arctic gloves. May open automatically at vacuum pressures above 6.0 psid. Can be mounted through a 0.51 in. (13 mm) dia. hole. Part No. **TA317**, without hex nut, installs in a 0.500-20 UNF-2B threaded boss.

Mounting Requirements: Each valve comes complete with nut and o-ring.
 Mounting hole diameter: 0.51 ± 0.01 (13 ± 0.25 mm)
 Installation torque: 30-40 in. - lbs. (3.4-4.5 N•m)
 Maximum wall thickness: 0.14 (3 mm)
 Add washer for wall thickness less than 0.03 (1 mm). (P/N MS15795-855, order separately.)
 For threaded boss installation: 0.500-20 UNF-2B; 0.51 ± 0.01 (13 ± 0.25 mm) diameter X 0.02 (1 mm) minimum deep counterbore required for thread relief. Part No. TA317 comes without hex nut.

TA321

Weight: 0.013 lbs.
6 grams
Housing: Aluminum
Finish: Anodize

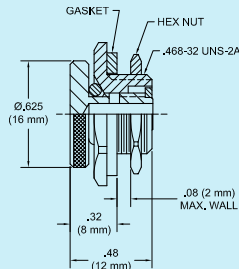
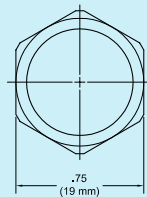

This minimum profile valve has a captive knurled twist knob for hand operation. The valve is black anodized and can be used in thin wall containers. It mounts through a 0.50 in. (13 mm) dia. hole. Meets MS18014-1.

Mounting Requirements: Each valve comes complete with nut and gasket.
 Mounting hole diameter: 0.50 ± 0.015 (12.7 ± 0.38 mm)
 Installation torque: 15-20 in. - lbs. (1.7-2.3 N•m)
 Maximum wall thickness: 0.08 (2 mm)
 Add washer for wall thickness less than 0.02 (0.5 mm). (P/N MS15795-855, order separately.)
 For threaded boss installation: 0.468-32 UNS-2B; 0.50 ± 0.015 (12.7 ± 0.38 mm) diameter X 0.02 (0.5 mm) minimum deep counterbore required for thread relief.

TA327

Weight: 0.053 lbs.
24 grams
Housing: Aluminum
Finish: Anodize

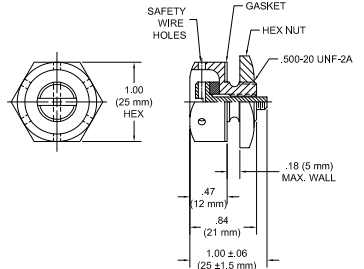
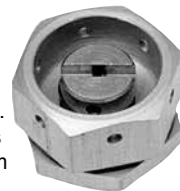

A medium-sized "turn-to-open" valve with a recessed captive screw that must be rotated 1 or 2 turns with a screwdriver or coin to open the valve. It has a safety wire feature. The TA327 meets the requirements of Nav Buweps Dwg. No. 1296841. The valve can be mounted through a 0.51 in. (13 mm) dia. hole. Part No. TA328, without the hex nut, installs in a 0.500-20 UNF-2B threaded boss.

Mounting Requirements: Each valve comes complete with nut and gasket.
 Mounting hole diameter: 0.51 ± 0.01 (13 ± 0.25 mm)
 Installation torque: 30-40 in. - lbs. (3.4-4.5 N•m)
 Maximum wall thickness: 0.18 (5 mm)
 Add washer for wall thickness less than 0.052 (1.3 mm). (P/N MS15795-855, order separately.)
 For threaded boss installation: 0.500-20 UNF-2A; 0.51 ± 0.01 (13 ± 0.25 mm) diameter X 0.052 (1.3 mm) minimum deep counterbore required for thread relief. Part No. TA328 comes without hex nut.

TA322 Filler Valve

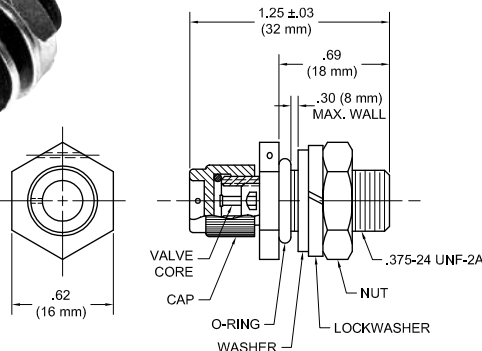

The TA322 Filler Valve provides a tire valve core in a lightweight minimum length housing. This valve may be used to purge or pressurize containers. An air chuck is required to actuate valve (not furnished by AGM). The cap may be secured to the housing by a user-supplied safety wire.

Mounting Requirements: Each valve comes complete with o-ring, washer, lockwasher, and nut.
 Mounting hole diameter: 0.385 ± 0.010 (9.75 ± 0.25 mm)
 Installation torque: 30-35 in. - lbs. (3.4-4.0 N•m)
 Maximum wall thickness: 0.30 (8 mm)
 Minimum wall thickness: 0
 For threaded boss installation: 0.375-24 UNF-2B; 0.385 ± 0.010 (9.75 ± 0.25 mm) diameter X 0.10 (2.5 mm) minimum deep counterbore required for thread relief.

Housing and cap are black anodized aluminum alloy. AN/MS mounting hardware is supplied.

Weight:
0.0302 lbs. (13.7 grams)

TO MEET SAE SPECIFICATION AS5017, ASK FOR TA322-1958



Breather Valves

AGM CONTAINER CONTROLS, INC.
PO BOX 40020 • TUCSON ARIZONA 85717-0020
TEL: 800-995-5590 (520) 881-2130 • FAX: (520) 881-4983
www.agmcontainer.com • sales@agmcontainer.com

APPENDIX

"METAL REUSABLE CONTAINER PERFORMANCE UNDER CONTROLLED ENVIRONMENTAL TESTING"

CLAIR L. McDERMIT

REPRINTED BY AGM CONTAINER CONTROLS, INC. WITH PERMISSION OF U.S. ARMY TANK AUTOMOTIVE COMMAND

Mr. McDermit was the Director of the Packaging Engineering and Development Branch of the U.S. Army Tank Automotive Command in Warren, Michigan. This presentation was made at the Fall 1970 meeting of the Packaging, Handling & Transportability Division of the American Ordinance Association (now the National Defense Industrial Association). Significant paragraphs are shown in bold type.

The Tank Automotive Command has very recently completed a study project intended to provide certain information relative to the performance of metal reusable containers. Project title and title of the final report is, "Comparative Environmental Tests of Selected Variables in Reusable Metal Shipping Containers." The final report is now in draft form and will be published shortly. A limited number of copies will be available for distribution. This study project was conducted under contract between the Tank Automotive Command and Ryco Engineering, Inc. in Warren, Michigan.

To avoid any misunderstandings as to the intent and objectives of this study, I will make it as clear and simple as I possibly can. This was not a research and development project. We were not attempting to prove or disprove whether container designs incorporating controlled breathing valves would perform adequately, or whether free-breathing containers were less adequate than the controlled type. Neither were we attempting to establish that in terms of storage life reliability the sealed, pressurized designs are superior to breather types. Our primary study objectives were to establish certain limited design parameters for controlled breathing type containers and to establish criteria for inspection and maintenance during storage for such container systems.

U.S. Army Tank Automotive Command has approximately 150 metal reusable container designs in existence. These are all, with one exception, the totally sealed, pressurized design. From the viewpoint of performance, there is no reason to change our designs. The pressurized containers have performed excellently and, when properly designed and fabricated, provide optimum protection under any and all conditions of shipment and storage.

Due to the pressurization requirements, these containers are excessively heavy. Our container-to-item weight ratio is approximately one-to-one and in some cases the container exceeds the weight of the item contained. In addition to the container weight, pressurization also influences design

characteristics, which increases exterior cube of the container. In order to withstand the 15 psi test pressure and hold a 5 psi shipping and storage pressure such containers are usually rounded or elliptical in configuration.

Some time ago, after considerable study of the degree and direction of movement of containerized items in an elastomeric shock mitigating system, during which we found that the item never moved three inches, we adopted a rectangular configuration as our basic design policy. We were successful in reducing cube by approximately 25%. However, any potential reduction in weight resulting from reduced size was offset by the need to increase container body cross section. Heavier cross section is required to withstand internal pressure on the flat surface.

During one recent fiscal year, the Tank Automotive Command procured approximately 50,000 steel reusable containers. Using very conservative computation factors, we estimate that by reducing the weight of our containers by an average of 25% we could save in a comparable procurement year 4.25 million pounds of shipping weight. In carload lots, the rate for engines and transmissions to one destination is approximately \$5.50 per hundred weight. The savings in weight would result in a transportation savings of \$233,750 per year. We believe the potential of 25% weight reduction by use of lighter weight non-pressurized design to be reasonably attainable.

So, as stated earlier, our objective was to determine whether high or low pressure activated valves were most desirable and to establish criteria for control and maintenance of breather type containers during storage. It is also worthy of note that any criteria established as a result of this test will, without any initial adjustment for variations in climatic regimes, be applicable to 80% of our storage areas around the world. This will be discussed at greater length later.

The containers used in this test were of all steel construction and had been procured several years previously for another project. As originally procured, the containers were the free-breathing type, bolted top with a flat rubber gasket between the top of container and the flat lid. The containers were modified for this test by welding the tops to the containers and providing for end access. The containers were 80 inches in length, 24 inches wide, and 23 inches deep. Except for framing members, the containers were made of 10 gauge steel. Eight of these containers were used in the test.

Instrumentation used for this study consisted of a 24 channel Bristol Recorder; temperature and humidity monitoring were by hygroscopic humidity and thermistor temperature pickups. Sensors were manufactured by Hydrodynamics. Pressures were monitored by Computer Instrument Company bellows type sensors. The system scanned all channels once each six minutes. During the two years the study ran, approximately two miles of chart were produced; 4,204,800 data bits were recorded on the instrument charts. These statistics are not given for the purpose of impressing anyone but rather to point out a problem that was recognized at the beginning of the study. The scope of the contract and funding limitations (it was a fixed price contract) did not permit the manual review, comparative analysis, and extrapolation of data beyond the limited scope established by the contract. Had the system been designed to provide data in computer input form, we would have had a much more versatile program. Any studies of this nature that we conduct in the future will be so designed.

The sensing and recording system was designed to provide the following information:

1. Container internal humidity
2. Container internal temperature
3. Container internal pressure
4. Ambient relative humidity
5. Ambient temperature
6. Atmospheric pressure

In addition to the above system output, contractor's engineers were also required to periodically weigh the various desiccant charges and record gains in weight. The contractor was also required, through interpretation of the machine recorded data, to determine and record how many times the controlled breather containers breathed. We had originally planned to weigh the desiccant in the containers by use of load cells. Due to the limitations of these systems, this plan was abandoned.

Each of the eight containers was placed on test with one or more variables relative to the other containers on test. Briefly, the individual container systems were as follows:

1. Pressurized at 5 psi with molecular sieve desiccant.
2. Controlled breather, +2 and -1 psi valves. Silica gel desiccant.

3. Controlled breather, +2 and -1 psi valves. Silica gel desiccant. Insulated internally with 1" polyurethane foam, 1 lb. density.
4. Controlled breather, +1 and -1/2 psi valves. Silica gel desiccant.
5. Pressurized at 5 psi. Silica gel desiccant.
6. Free-breather. Molecular sieve desiccant.
7. Free-breather. Silica gel desiccant.
8. Free-breather. Silica gel desiccant. Internally insulated with 1" polyurethane foam, 1 lb. density.

The test site was adjacent to the contractor's engineering facility on 9 Mile Rd., in Warren, Michigan. The first location selected by the contractor was rejected because it did not permit proper exposure of the containers. The area selected provided good security but it would only provide a few hours of direct sunlight per day, having a high shrubbery wall on one side and the building wall on the other. The next location selected was later abandoned by the contractor because his studies showed that containers would be affected by heat and the shadow of the building. The final selection was an area near the center of the company parking lot. This area was enclosed within a six foot cyclone fence with a locked gate. Figure 1 is an artist's view of the test site. Cables from the various sensing devices were run overhead to the rear of the main building. The recording instrument was indoors in the main building.

FIGURE 1. TEST SITE

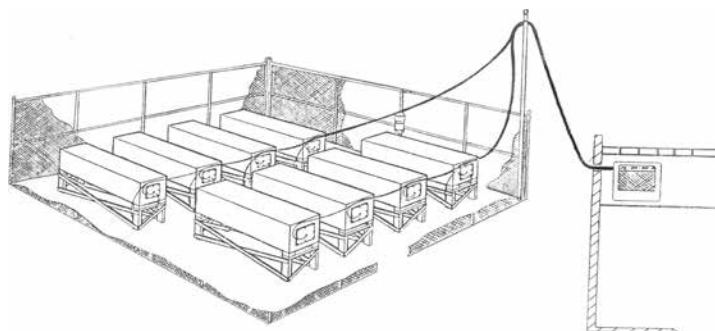

Figure 2 shows the system diagram of the various container configurations and sensing channels. This includes the eight containers and the ambient humidity, temperature and atmospheric pressure sensors.

FIGURE 2. CONTAINER ARRANGEMENT AND CONNECTIONS

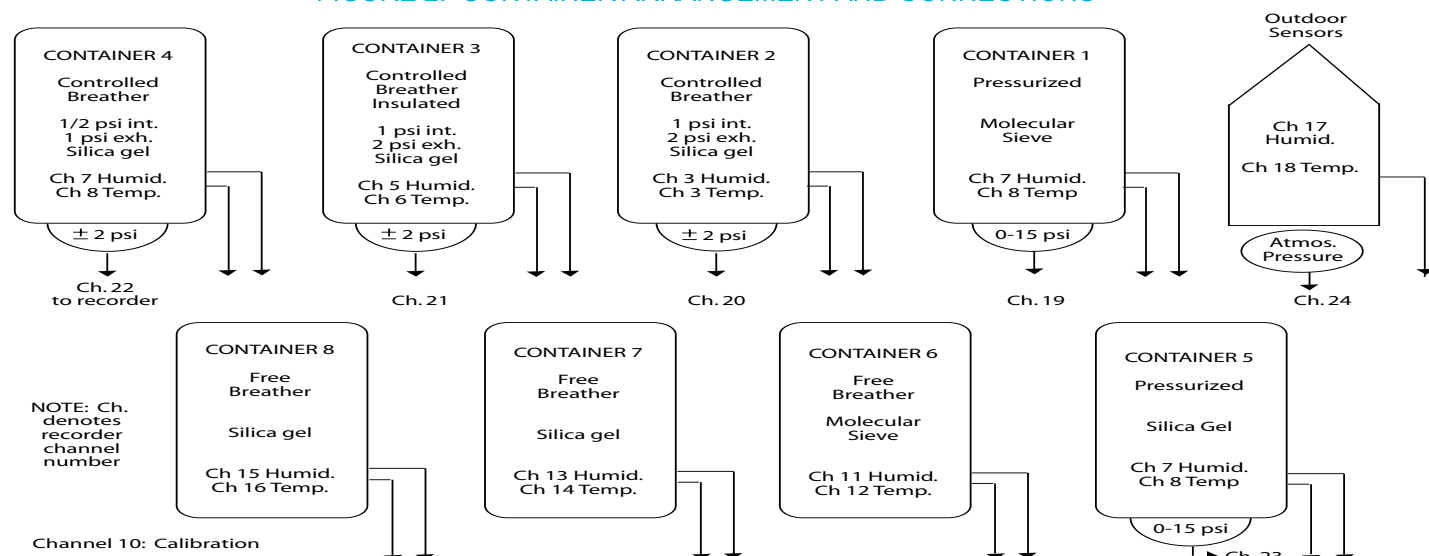

Figure 3 shows one of the containers on its stand and the location of cable connectors and valves.

FIGURE 3. CONTAINER EXTERIORS & MOUNTING STANDS

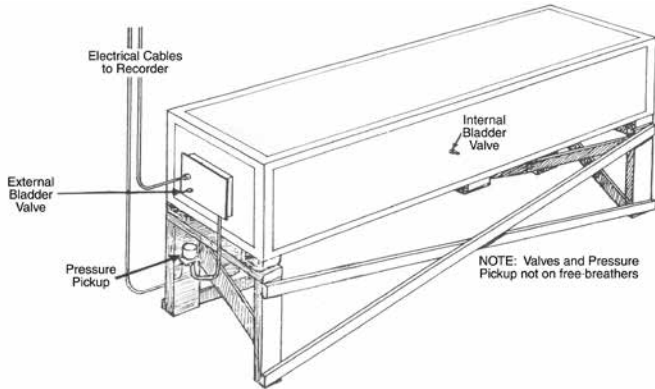

Figure 4 is a cut-away view showing the pressure equalizer system used. It also shows the position of the desiccant holder and sensing element. The pressure equalization function was only used on the controlled breather type containers. In order to minimize the effect of removing the desiccant holder and valves each time the desiccant was weighed, an attempt was made to bring the internal pressure differential to zero before opening.

FIGURE 4. CONTAINER INTERIORS AND PRESSURE EQUALIZING BLADDERS

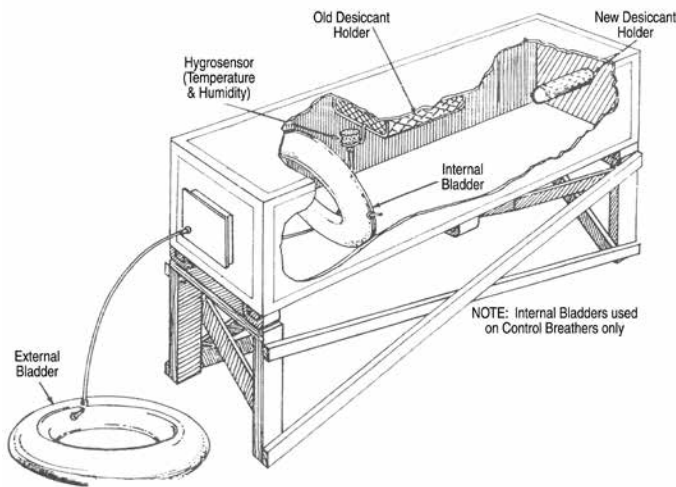
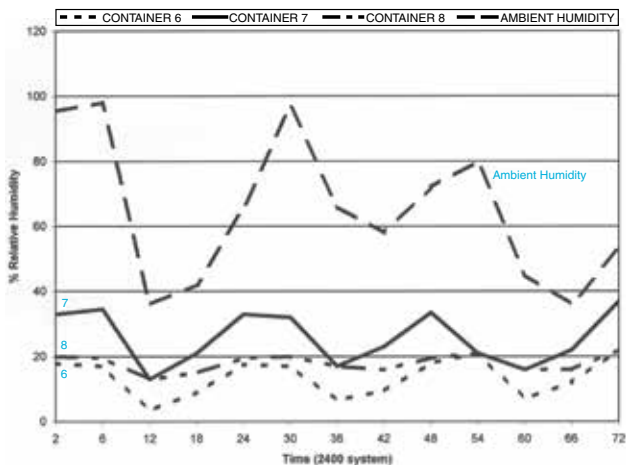

FIGURE 5. CONTAINERS 6, 7 AND 8 HOURLY HUMIDITIES FOR SEPT. 4-6, 1968



I must caution anyone who may read the official report to do so with certain reservations. We anticipated at the start of the study that in all probability our findings would reveal many areas where additional study would be useful and profitable. As we anticipated, this has been the result. The answers required by the study were obtained. We are very satisfied with the results. The questions raised by observation and recognition of certain side effects and phenomena appear to have impressed the engineers conducting the test to the point where discussion of potential studies overshadow the good results attained. The matter of future study recommendations will be covered later.

As stated previously, we wanted to determine by means of this study how efficiently breather type containers function, and how efficiently such systems worked in comparison to each other. The data we have developed will be used as guidance in the design effort and in technical publications, such as Storage Serviceability Standards.

In regard to the findings, I am sure that many will say that much of this is not new. To this I can agree without argument. However, there has been very little recorded data available which was both comprehensive and comparative. To this extent, we believe the study is moderately unique.

Both the free-breather and the controlled pressure breather containers performed far better than we expected. Our previous experience with free-breathers did not give us any basis for expecting more than six months useful life for the desiccant charge. All three of the free-breathers remained in control relative to average relative humidities per day for 13 to 19 months. While we retain our previous conclusions relative to the free-breather principle, the results of this study demand that we have an open mind for future consideration and further study. At the present time, however, we have no intention of going to free-breathers. The following selected charts graphically depict our recorded experience with the free-breather containers during the two year test. These individual charts are plotted averaging some of the data recorded every six minutes by the instrument system. Figures 5, 6 and 7 show the ambient relative humidity and internal relative humidity for containers 6, 7 and 8. Container 6 is shown as a line of short broken dashes; container 7 as a solid line; container 8 as a line of dashes with two dots.

FIGURE 6. CONTAINERS 6, 7 AND 8 HOURLY HUMIDITIES FOR JAN. 26-28, 1969

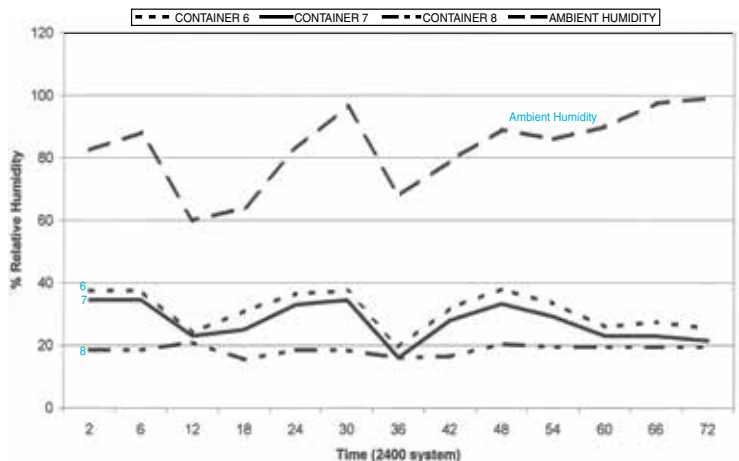
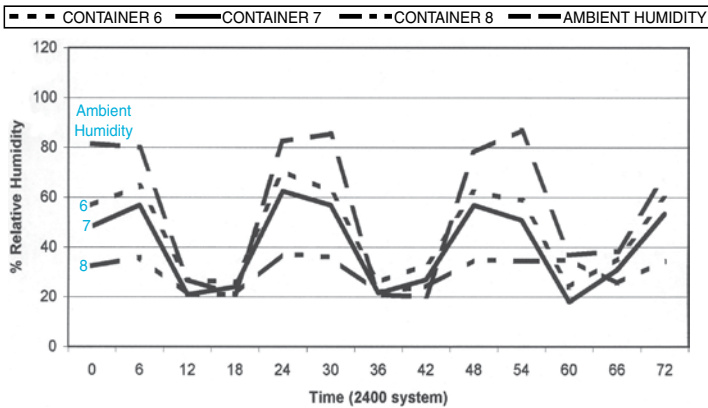

FIGURE 7. CONTAINERS 6, 7 AND 8 HOURLY HUMIDITIES FOR JULY 1-3, 1969



This is stressed to alert you to the fact that on later graphs in the report the identity is changed. Container 6, which was desiccated with molecular sieve, remained in control for 13 months. This was the shortest period of the three free-breathing containers. At first glance, this could be a minus value for molecular sieves. I am not accepting that conclusion. Pending further analysis, we are attributing the shorter life to the more aggressive moisture "grabbing" characteristic of the molecular sieves. In free-breather type applications this could be a plus value characteristic. We will discuss molecular sieves at greater length later. Container 7, which was desiccated with silica gel, stayed in control for approximately 14 months. Container 8, desiccated with silica gel and insulated with 1" of polyurethane foam, was good for 20 months.

In regard to the controlled pressure breather containers, I have very little to show you in the form of relative humidity graphs. The reason for this is quite simple, although somewhat unbelievable. The containers, after drying out internally within approximately 30 days, never got off zero relative humidity (RH) during the entire period of the test, except in the case of container 4 which did show a slight rise for one period after a year and a half.

In regard to this continuous 0% RH, we were very dubious and as a result, when the test was completed and dismantled, I had all instrumentation brought in to our Calibration Laboratory for a complete check-out. Calibration results indicated that acceptable accuracy was not present below 16% RH. So whenever I or the report refers to 0% RH, it must be taken as any percent from 0 to 16. We do know that the container atmosphere, with one exception noted, stayed within this low range throughout the entire two year test. If the relative humidity records were the only data obtained, we would be in trouble in making a decision between systems. However, breathing cycles and weight gain of desiccants are variables recorded and evaluated during this study.

It will be recalled that we had three controlled pressure breather containers on test. Container 2 was controlled at -1 psi and +2 psi and was charged with silica gel desiccant. Container 3 was the same as No. 2 except that the container was insulated. Container 4 was controlled at -1/2 psi and +1 psi. This container also had silica gel desiccant. I regret that we did not use molecular sieve in one of the controlled pressure breathers. With the variables involved, we are able to assess the difference between the systems.

Frequency of breathing was one of the variables to be evaluated. Before the test was actually started, we found that we were in some trouble in relation to accurately determining when the valve opens and when it closes. When we first established the parameters for the study, I wanted monitoring the valve action electronically recorded. Our Instrument Laboratory decided that this would be complex, expensive and subject to high maintenance requirements. It was considered (on a theoretical basis) to be unnecessary inasmuch as we would be sensing on internal pressures and this should signal valve action by pressure change. In theory this is so—in practice the way the available valves function, it is not so good. Table I of the report gives a monthly summation of the frequency of breathing for containers 2, 3 and 4.

TABLE I. CONTAINER BREATHING FREQUENCIES

MONTH	CONTAINER NUMBER					
	4		3		2	
	IN	OUT	IN	OUT	IN	OUT
Jan. 1968	9	0	1	0	1	0
Feb.	6	6	0	0	0	0
March	13	22	0	0	0	0
April	22	21	0	0	0	1
May	18	20	0	0	0	2
June	10	31	0	0	0	4
July	14	35	0	0	0	0
Aug.	12	39	0	0	0	0
Sept.	12	14	0	0	0	0
Oct.	9	8	1	0	1	0
Nov.	4	1	0	0	0	0
Dec.	7	2	1	0	2	0
1968 TOTAL	136	199	3	0	4	7
Jan. 1969	6	7	1	0	1	0
Feb.	2	4	0	0	0	0
March	8	17	3	0	0	0
April	13	17	0	0	0	2
May	16	24	0	2	2	1
June	14	13	0	0	3	1
July	9	22	0	1	0	0
Aug.	12	24	0	0	0	0
Sept.	9	12	0	0	0	0
Oct.	6	6	1	0	1	1
Nov.	2	1	1	0	1	0
Dec.	2	3	1	0	1	0
Jan. 1970	3	3	1	0	1	0
1969 TOTAL	102	153	8	3	10	5
1968-69 TOTAL	238	352	11	3	14	12

Container 4 breathed in 238 times and exhaled 352 times during the two year test. Container 4 was the low pressure container -1/2 psi + 1 psi. Container 3 breathed in 11 times and exhaled 3 times during the test. This was the insulated breather with -1 psi +2 psi valves. Container 2 inhaled 14 times and exhaled 12 times. Because of the fact that cracking action of the valves is not a precise function of opening at an exact pressure and then dumping the pressure differential in a prescribed period of time, we suspect that breathing took place without detection.

We obtained specially manufactured valves that were supposed to be precision type. We found, however, that the valve action was a partial opening with gradual dissipation of the pressure differential. Minute pressure change over a considerable period of time (1 or 2 hours or longer) was difficult to determine from the recorder charts. We also suspect that, at least in the case of the higher pressure valves, that breathing was prevented by the container adjusting itself physically to the pressure change by "oil canning." This is a phenomena that needs more study as a potential design feature.

In regard to desiccant weight gains, which for the purpose of this study we equate with water, the study has produced some interesting data. Figure 8 plots the desiccant weight gain for containers 2, 3, 4, 6, 7 and 8. Containers 1 and 5 were the pressurized containers. The silica gel and molecular sieve in containers 1 and 5 were only weighed at the beginning and end of the two year test. It is noted at this time that at the start of the test 10 grams of free water were introduced into each container. Any weight gain recorded must be qualified by subtracting 10 grams from the total gain. It is also noted that, had this water not been added, pull down time would have been less than the 30 days we experienced. Including Nos. 1 and 5 pressurized containers, we had the following weight gains:

- Container #1: Pressurized, molecular sieves, at 27 months had gained 28.7 grams.
- Container #5: Pressurized, silica gel, at 27 months had gained 21.6 grams.

- Container #2: Controlled breather, 1 psi - 2 psi, silica gel, after one year, 21.10 grams; after 27 months, 24.80 grams.
- Container #3: Controlled breather, insulated 1 psi - 2 psi, silica gel, after 1 year, 32.69 grams; after 27 months, 41.40 grams.
- Container #4: Controlled breather, 1/2 psi - 1 psi, silica gel, after 1 year, 24.8 grams; after 27 months, 32.3 grams.

NOTE: Containers remained on test 3 months after expiration of contract. The contractor suggested that the test continue until warmer weather at his expense. We accepted. The 3 free-breather containers in 18 months gained as follows:

- Container #6: Free-breather, molecular sieve, after 1 year, 158 grams; after 18 months, 169 grams.
- Container #7: Free-breather, silica gel, after 1 year, 131 grams; after 18 months, 179.95 grams.
- Container #8: Free-breather, insulated, silica gel, after 1 year, 116 grams; after 18 months, 132 grams.

Desiccant was weighed on the following schedule: pressurized container at start and finish of test; free-breathers every seven days; controlled breathers every 30 days.

I cannot attempt to explain some of the seeming contradictions of these values. We have not completed our analysis of the data and, in some cases, complete analysis without further testing will not provide an answer. A good example is Container 4. This container, with the 1/2 psi - 1 psi valves, inhaled 224 times more often and exhaled 340 times more often than the next higher container. Container 4, however, had a desiccant weight gain of 32.30 grams against 41.40 grams for Container 3. One answer which suggests itself is out-gassing of the moisture during breathing cycles. The out-gassing theory can also explain

FIGURE 8. DESICCANT WEIGHT GAINS FOR 1968-1970

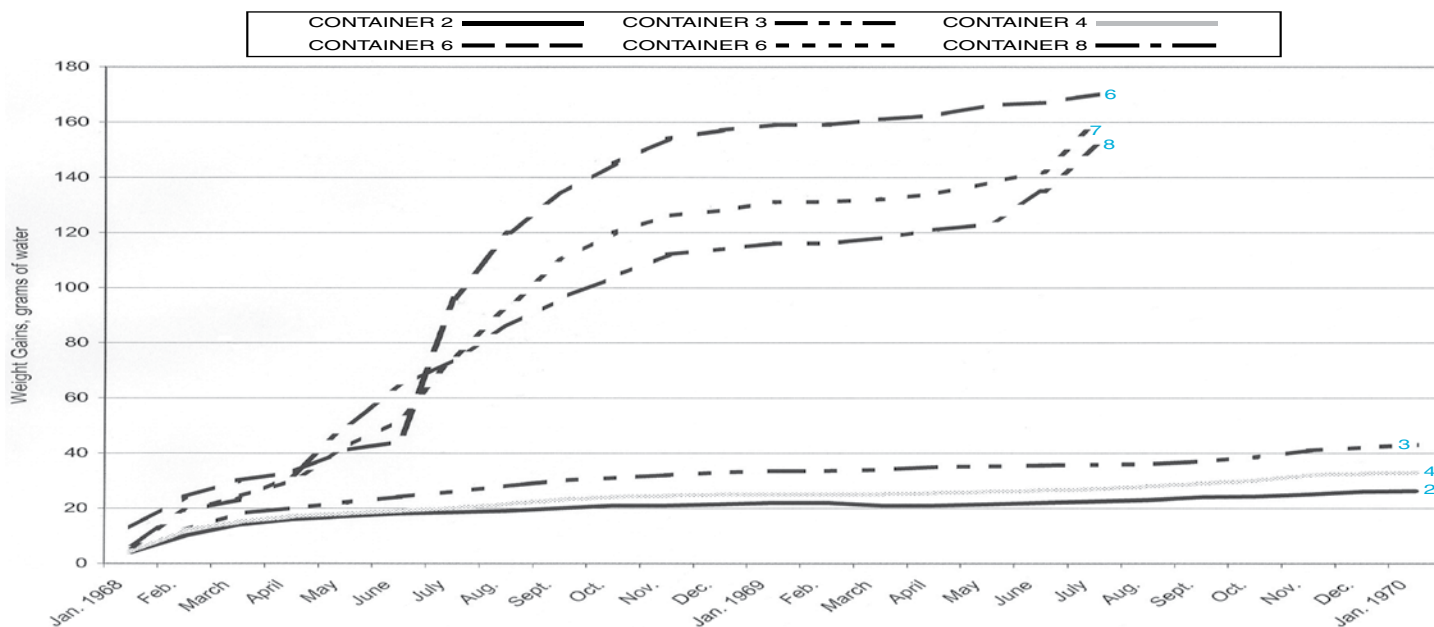

the greater weight gains of the molecular sieves. In addition to its demonstrated ability to pick up water faster, in greater quantity its higher reactivation temperature could result in retention of the water it has captured. This is an area which we hope we can study further in the very near future. Desiccant weight gains by percentage are as follows. All figures are approximate.

- Container #1: Pressurized, molecular sieve, 3%
- Container #2: Controlled breather, 1 psi - 2 psi, silica gel, 3%
- Container #3: Controlled breather, 1 psi - 2 psi, insulated, silica gel, 5%
- Container #4: Controlled breather, 1/2 psi - 1 psi, silica gel, 4%
- Container #5: Pressurized, silica gel, 2.5%
- Container #6: Free-breather, molecular sieve, 17%
- Container #7: Free-breather, silica gel, 20%
- Container #8: Free-breather, silica gel, 15%

In regard to our conclusions, we have arrived at the following:

a. We can convert to a design policy of controlled breather containers without imposing any significant additional workload on the supply system. We will initially establish a shelf life limit of five years without necessity of recharging desiccants in all climates except marine-tropic climatic regimes. In such, climates we will limit shelf life to three years until storage experience is gained.

b. On the basis of our study we will in all probability use the 1 psi - 2 psi valve.

c. We believe that molecular sieves may be the desiccant to use in breather systems but feel that some additional study and analysis is required.

d. All new designs for Tank Automotive Command items will be controlled breather containers.

e. Our experience with the instrumentation used on this test has done nothing to create confidence in systems using electronic humidity sensing devices. We were confronted with problems of air pollution which seriously corroded the sensing elements. It was necessary to repair and replace the probes a number of times during the study. While these devices are not used relative to containers, we have been and are involved in dehumidification systems for ships and structures. This matter of corrosion is discussed at length in the report.

In respect to matters requiring further study, we believe the following matters to be of sufficient importance and potentially beneficial to require study in depth.

a. Desiccant formulae. Because of our findings during this study, we are convinced that desiccant formulae requires overall review and revision. We believe the formulae used results in excessive use of desiccant at least for some types of packs, such as pressurized metal containers. We need to establish new formulae for breather type containers and for use of molecular sieves. This is an area requiring additional study and investigation.

b. Further study is needed relative to the effect of sunlight and shadow on breather containers. Our analysis of test results to date indicate that you can expect longer shelf life from a controlled breather container and from free breathers when they are protected from direct sunlight. In simple terms, a group of containers in outdoor storage will have some containers in the inner rows protected on all sides from sun, wind, rain, etc. The life of the inner rows will be considerably longer than those in the outer rows and tiers.

c. The "oil canning" phenomena also needs further study. This study should be made in connection with additional study on valve pressures and container strengths required for breather systems. The primary constraint against container weight after adoption of the breather principle is not pressure—it is requirements for stacking strength. If design advantage can be taken of the ability of the container to adjust itself to pressure differentials, it is questioned whether balanced pressure valves are required.

d. Self-activation out-gassing is another phenomena for study and development of controls that will make this a design feature of breather systems. We know (although our contractor apparently did not) that this is no new discovery of principle. We are familiar with and have had successful tests using the Solar Radiation Breathers developed by Davidson Chemical Company some years ago.

In summary, we are not implying that we have made any startling discoveries or technological break-throughs. No new scientific principles have been developed. We do feel, however, that we have attained much good data on which to base our future designs and storage controls. As we have the opportunity for deeper analysis of the data obtained, we have no doubt that we will be further enlightened.

Thank you for your attention.

QUALITY PRODUCTS FROM

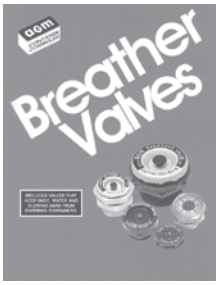

Catalog "B"



Catalog "IP"

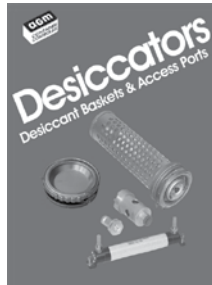

Catalog "D"



Catalog "T"

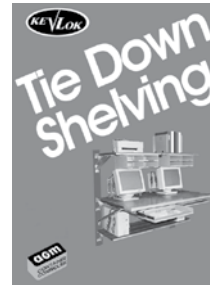

Catalog "K"



Catalog "SD"

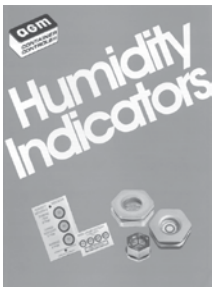

Catalog "H"

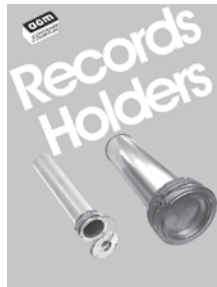

Catalog "R"



Catalog "P"



Catalog "DV"



Catalog "S"



Catalog "SW"

AGM CONTAINER CONTROLS, INC., backed by four decades of leadership in the manufacture of container hardware, has developed many products for military, electronic and industrial packaging, handling, storage and transportation applications. Individual catalogs (illustrated above) describing these products are available upon request. You are also cordially invited to phone, fax or e-mail for specific information regarding custom design, or to request assistance on your current and future requirements.

BREATHER VALVES Prevent excessive pressure or vacuum buildup in sealed containers, reducing weight, cube and cost. Meet SAE AS27166. Related item: Manual Relief Valves.

IMMERSION PROOF BREATHERS Permit air pressure equalization, but keep out liquid water. For use on membrane keyboards and similar pressure sensitive equipment that must operate under rain or water submersion conditions.

DESICCATORS Standard and custom-designed static drying units to fit a wide variety of applications. Valves and/or humidity indicators can be incorporated.

TIE DOWNS Patented over-center action of KevLok® fastener locks in tension. Adjustable. Holds tight, with quick release. Assemblies for military, industrial and recreational purposes. Also available: ratchet and cam buckle assemblies.

TIE DOWN SHELVEING For transport of delicate instruments in vans, trailers, etc. Meets Navy MIL-S-901D shock test for shipboard use. Padded aluminum shelving has recessed channels which accept adjustable KevLok® straps with quick attach/release end fittings.

SHELTER STATIC DEHUMIDIFIERS (SSD) Protect COTS equipment in mobile shelters for up to two years on a single bulk desiccant charge. Can be recharged from outside shelter.

HUMIDITY INDICATORS Provide external monitoring of humidity levels inside containers. Meet SAE AS26860. Related items: Propellant Leak Detectors and Observation Windows.

RECORDS HOLDERS Provide access to documentation or accessories without opening container. Records Holders compartment is sealed from the inside of the container.

DESICCANT AGM is a stocking distributor of Süd-Chemie Performance Packaging's Desi Pak® (which exceeds MIL-D-3464E requirements maintained within MIL-STD-2073-1C), Sorb-It®, Tri-Sorb®, Desi View® and Container Dri® products. Custom packaging of bulk desiccant available.

DRUM VENT DRYERS Prevent contamination of chemical products (powders, liquids and semi-solids) in 55-gallon storage drums. Reusable – saturated color change silica gel desiccant is easily replaced.

SHOCKMASTER® Shock overload indicators provide low cost detection of transport and handling damage. Compact, accurate and reusable. "Red-flags" shipments which have been subjected to excessive shock or vibration.

SHOCKWATCH Single-use impact-detection device guards against careless handling. Self-adhesive label incorporates a tiny liquid filled tube that turns red when package is dropped.

Employee
Owned



AGM CONTAINER CONTROLS, INC.
3526 E FT LOWELL RD • PO BOX 40020 • TUCSON AZ 85717-0020
TEL: 800-995-5590 (520) 881-2130 • FAX: (520) 881-4983
www.agmcontainer.com • sales@agmcontainer.com

