

PRESIDENT

Spiral Mixer, Wheel-out
6 Construction sizes, 75 to 250 kg of flour



The **WP BAKERY**GROUP – with this portfolio of companies, we’ve comprehensively aligned ourselves with the needs of bakeries worldwide. Today we are in a position to offer total solutions – from project development for equipping complete bakeries (craft and industrial) to offering used machinery.

The central element of our corporate philosophy is a networked way of thinking that stretches beyond the individual stages of production. We call it “process management”, the targeted management of the individual stages of production and the machines used within them – as fast as possible and with optimal use of material to achieve the desired result, even for small amounts – and the unlimited reproducibility of results achieved. And all this is combined with extremely high yield.

Each unit can be operated as a “stand-alone”, but can also be easily “docked on” at any time – interfaces for third-party products are sufficiently available.

 **Werner & Pfleiderer**
Bakery Technologies

 **Haton**

 **Werner & Pfleiderer**
Industrial Bakery Technologies

 **Kemper**

 **Werner & Pfleiderer**
Bakery Cooling

 **Winkler**

 **Werner & Pfleiderer**
Instore Baking

 **BackNet**
Bakery Software

 **Werner & Pfleiderer**
Bakery Service

 **Werner & Pfleiderer**
Bakery Consulting

WP CompetenceCenter

- _ Dough/Mixing.** Emil Kemper GmbH, Rietberg
- _ Rolls.** Emil Kemper GmbH, Rietberg
- _ Bread.** Werner & Pfleiderer Haton B.V., NL-Panningen
- _ Ovens.** Werner & Pfleiderer Lebensmitteltechnik GmbH, Dinkelsbühl
- _ In-store baking.** Werner & Pfleiderer Sachsen GmbH, Sohland
- _ Refrigeration technology.** Werner & Pfleiderer Koeling Benelux B.V., NL-Panningen
- _ Laminating .** Werner & Pfleiderer Lebensmitteltechnik GmbH, Dinkelsbühl
- _ Engineering.** Werner & Pfleiderer Industrielle Backtechnik GmbH, Tamm
- _ Used machines.** Werner & Pfleiderer Sachsen GmbH, Sohland
- _ Bakery software.** BackNet E&S GmbH, Muggensturm

www.wpbakerygroup.com/competencecenter



WP BAKERYGROUP

PRESIDENT MIXER

*The industrial use of mixers requires extremely robust material and a high manufacturing quality. Mixers in the construction range **PRESIDENT** from **WP KEMPER** fulfil the necessary requirements for their operating area. We manufacture them extremely robust, on request also with a stainless steel frame, and equip them with forged mixing tools and highly polished stainless steel bowl. The drives, with a highly dimensioned capacity, which have extensive safety reserves, a specially designed Fork Locking system in connection with a DUO Frictional Wheel Drive ensure a smooth operation in all revolving levels, even with lower dough absorption rates. The bowl change is comfortable and occurs with very little strength requirement. A useful addition to this machine is, for example, our OXYLATOR, where the water used can be enriched with Oxygen.*



Kemper—Since 1898 we have been developing, manufacturing and installing machines and plants for the production of Bakery products. Today we are one of the World’s leading suppliers of intelligent solutions for dough production and processing. Within the **WP BAKERYGROUP** we are responsible for the product range of “Dough Mixing” and “Roll Plants”. Our product portfolio includes Mixers, Mixing Systems, Dough Conveying Systems, Dough Dividing & Moulding Machines, as well as Roll Plants.

We supply technical solutions that satisfy the highest demands. Together with the client, we develop concepts, that meet the market requirements, resp. that set trends for the future of the branch—for Craft Bakeries as well as the Industrial production.

As a continuation of our tradition we have developed the **PRESIDENT** Mixer. It encompasses our entire knowledge and experience from more than 70 years of mixer production; **Kemper** is, among other things, inventor of the 3 Zone Mixing Principle (Spiral / Guide bar). With a total of 6 models, we cover the entire spectrum for the customary charging ranges from 75–250 kg of flour.

Mixing _ Conveying _ Resting _ Conveying _ Charging



PRESIDENT

Bowl volume 120 to 400 kg dough



The **PRESIDENT Mixer** range from **WP Kemper** covers, with the six mixers in this product range, the entire spectrum for the customary operating capacities used in craft and industrial applications: 75, 100, 125, 150, 200 and 250 kg flour can be processed in 3 shift operations. Highly durable construction modules ensures the extreme robustness of the **PRESIDENT**.

All models are constructed with the renowned **Kemper 3 Zone Mixing Principle** (Spiral and Guide Bar), which is distinguished through the exceptionally light and easy to process doughs, as well as a high water absorption and excellent blending effect (low dough temp. increase). A hydraulically driven fork locking system ensures a secure connection between the bowl and drive. This drive is equipped with 2 frictional wheels (DUO-Drive) and gives a smooth, stable operation through all phases of the mixing process. The drive is in addition to this flexibly mounted, where the pressure is controlled by gas pressure springs. Any wear is therefore kept to a minimum and the dough production is extremely gentle.

During the construction of the **PRESIDENT** great value was placed in the bowl handling. They are equipped with three wheels (one of which is pivot mounted) and can be moved without the need of great force. The "easy to move and dock" system alleviates wheeling the bowl in and out of the mixer and the large ground clearance allows easy cleaning.

Each model is manufactured with either a painted housing or completely in stainless steel.



75

100

125

150

200

DOUGHS		CAPACITY			SPECIALS
		Flour	Dough	Litre	
Wheat doughs	PRESIDENT 75	75 kg	120 kg	175	<ul style="list-style-type: none"> - Especially stable construction for constant operation in Multi-Shift Bakeries - Renowned Kemper 3 Zone Mixing System, for light easy to process doughs - Gentle dough production with low increase in dough temperature - Very robust high pressure fork locking system for stable connection for bowl / drive - Extremely strong DUO Direct Drive, for smooth continuous operation - "Easy to move and dock" system for light bowl handling - Integrated hygiene concept for simple cleaning
Mixed wheat doughs	PRESIDENT 100	100 kg	160 kg	235	
Mixed rye doughs	PRESIDENT 125	125 kg	200 kg	300	
Rye doughs	PRESIDENT 150	150 kg	240 kg	350	
	PRESIDENT 200	200 kg	320 kg	450	
	PRESIDENT 250	250 kg	400 kg	630	



250



Kemper 3 Zone Mixing Principle

(Spiral and Guide Bar) for light, easy to process doughs, with a low increase in dough temperature.



WP Kemper Rye Dough Mixing Tool

For heavy doughs.



Hydraulic Fork Locking System

For a secure connection.

Double (DUO) Bowl Drive

For a smooth, stable operation.



“Easy to move and dock”

System For simple bowl handling.

Large Ground Clearance

(approx. 150 mm) for problem free cleaning.



Switch box

With an additional manual switch for direct operation.



Touch Panel for simple and comfortable operation.

PRESIDENT

Reliable dough production around the clock







OXYLATOR

Oxygen induction during the mixing process

The OXYLATOR was developed to significantly increase the oxygen content during mixing (Ideal value 60%). The KEMPER 3 Zone Principle already supplies a noticeable contribution to increasing the oxygen input, through the optimised alignment of the mixing tools, but is limited due to the oxygen (O₂) content being just around 21% in ambient air.

The process operates through a 'Water Mist' principle and leads to a considerably increase oxygenation O₂ of the flour / water suspension: The complete water requirement is sprayed under pressure during the blending phase, using Micro-Jets. The water mist ensures an even distribution over the flour and an optimal mixing environment. The result is an improved blending process, the mixing phase sets in earlier, the flour absorbs more water, the dough development is ideal, larger product volumes are achieved – and all this with a saving on baking additive.



Slit Rolls
2% Baking Additive
with oxygen

Slit Rolls
4% Baking Additive
without oxygen

Pre-proofed frozen

Pre-proofed frozen



The OXYLATOR was developed together with the BILB Institute, Bremerhaven.

- Increase of the dough absorption by approx. 2% with the same dough consistency
- Reduction of baking additive by up to 50% with improved dough characteristics
- No additional commodities required, as the oxygen is produced through a generator
- Greatly improved Freeze / Thaw Stability with frozen dough pieces
- Possibility to process doughs immediately, as they are more malleable and not so we
- Fast Return On Investment

CAPACITIES



WP Kemper President 75

Quantities

75 kg Flour
120 kg Dough
175 l

Drive capacity

Spiral 3,2/ 10 kW
Bowl 2 x 0,25 kW
Hydraulic 0,75 kW

Fusing

32 Amp / CEE 32 A

Extras

Temperature sensor PT 100
Revolution counter
Touch Panel "Mono" or "Colour"
Stainless steel machine body
Bowl scraper
Multi-Phase control
CO² Cooling
Drain hole for bowl
Water supply
Energy meter
Version with mobile body

WP Kemper President 100

Quantities

100 kg Flour
160 kg Dough
235 l

Drive capacity

Spiral 12/ 20 kW
Bowl 2 x 0,375 kW
Hydraulic 0,75 kW

Fusing

50 Amp / On site

Extras

Temperature sensor PT 100
Revolution counter
Touch Panel "Mono" or "Colour"
Stainless steel machine body
Bowl scraper
Multi-Phase control
CO² Cooling
Drain hole for bowl
Water supply
Energy meter

WP Kemper President 125

Quantities

125 kg Flour
200 kg Dough
300 l

Drive capacity

Spiral 12/ 20 kW
Bowl 2 x 0,375 kW
Hydraulic 0,75 kW

Fusing

50 Amp / On site

Extras

Temperature sensor PT 100
Revolution counter
Touch Panel "Mono" or "Colour"
Stainless steel machine body
Bowl scraper
Multi-Phase control
CO² Cooling
Drain hole for bowl
Water supply
Energy meter



WP Kemper President 150

Quantities

150 kg Flour
240 kg Dough
350 l

Drive capacity

Spiral 12/20 kW
Bowl 2 x 0,375 kW
Hydraulic 0,75 kW

Fusing

50 Amp / On site

Extras

Temperature sensor PT 100
Revolution counter
Touch Panel "Mono" or "Colour"
Stainless steel machine body
Bowl scraper
Multi-Phase control
CO² Cooling
Drain hole for bowl
Water supply
Energy meter

WP Kemper President 200

Quantities

200 kg Flour
320 kg Dough
450 l

Drive capacity

Spiral 22/35 kW
Bowl 2 x 0,75 kW
Hydraulic 2,2 kW

Fusing

80 Amp / On site

Extras

Temperature sensor PT 100
Revolution counter
Touch Panel "Mono" or "Colour"
Stainless steel machine body
Bowl scraper
Multi-Phase control
CO² Cooling
Drain hole for bowl
Water supply
Energy meter

WP Kemper President 250

Quantities

250 kg Flour
400 kg Dough
630 l

Drive capacity

Spiral 22/35 kW
Bowl 2 x 0,75 kW
Hydraulic 2,2 kW

Fusing

80 Amp / On site

Extras

Temperature sensor PT 100
Revolution counter
Touch Panel "Mono" or "Colour"
Stainless steel machine body
Bowl scraper
Multi-Phase control
CO² Cooling
Drain hole for bowl
Water supply
Energy meter

CHECK

Pos I	Advice	Planning, Construction, Equipment, References, Tests
Pos II	Equipment	Hardware, Software, Mechanics, Options, Baker Know-How
Pos III	Modularity	Area available, retro-fits
Pos IV	Capacity	Pieces/hr, Volumes, Weights
Pos V	Quality	Dough Absorption, Dough Quality, Temperature, Taste
Pos VI	Costs	Investment, Current Costs, ROI
Pos VII	Workflow	Interface, Process Management
Pos VIII	System Responsibility	Complete system integration, Setting up individual processes
Pos IX	Service	Self service, Service presence, Remote maintenance
Pos X	Group Know-How	Process thinking, Interface Know-How, Solutions from one hand

PROCESS

- _ Request
- _ Production Analysis
- _ Concept creation
- _ Planning
- _ Offer
- _ Order
- _ Production
- _ Acceptance
- _ Delivery
- _ Assembly
- _ Integration
- _ Installation
- _ Training
- _ Service



DIMENSIONS & WEIGHTS

PRESIDENT 75

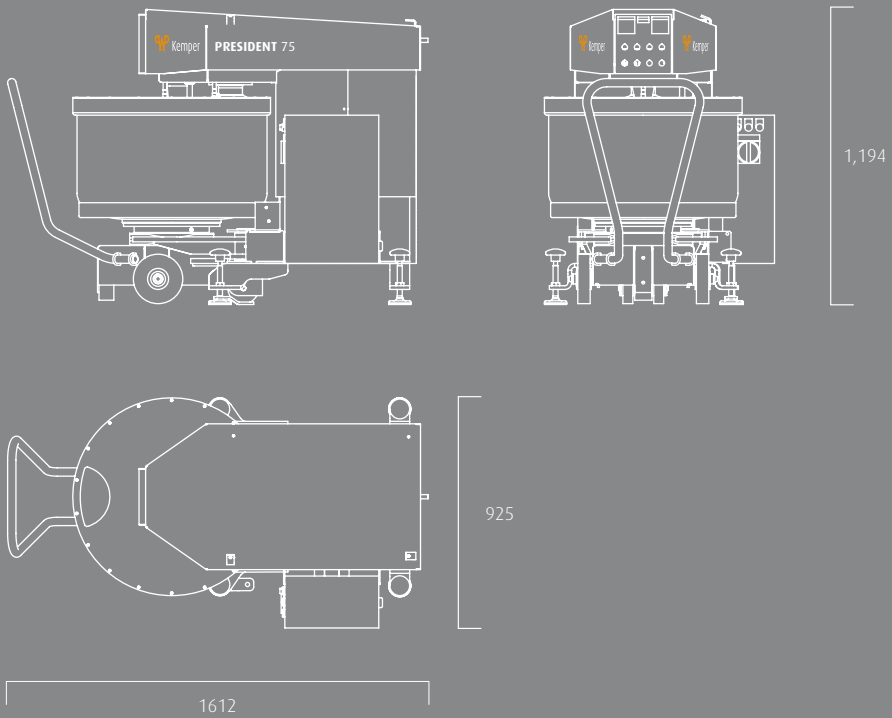

	Dimensions					
	P 75	P 100	P 125	P 150	P 200	P 250
Length	1,655	1,905	1,905	1,925	2,355	2,355
Width	925	1,150	1,150	1,200	1,540	1,540
Height	1,195	1,265	1,265	1,200	1,535	1,535
Head raised	1,655	1,790	1,790	1,740	2,145	2,145

PRESIDENT 250

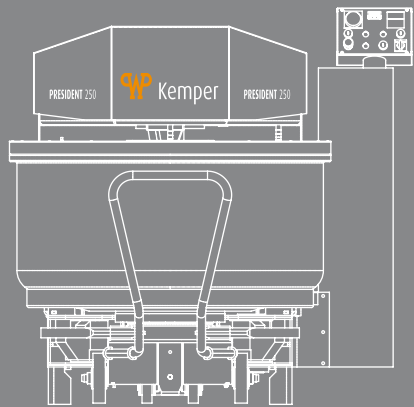
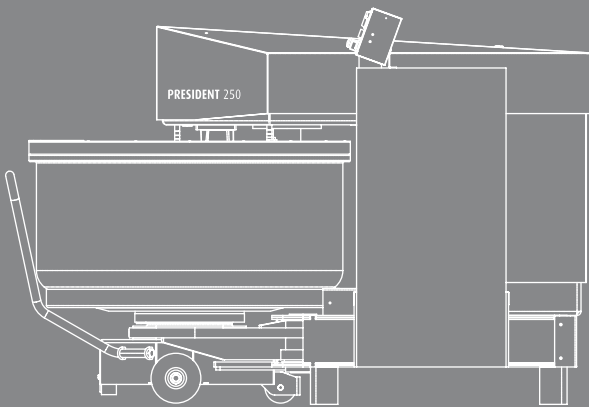

1,588

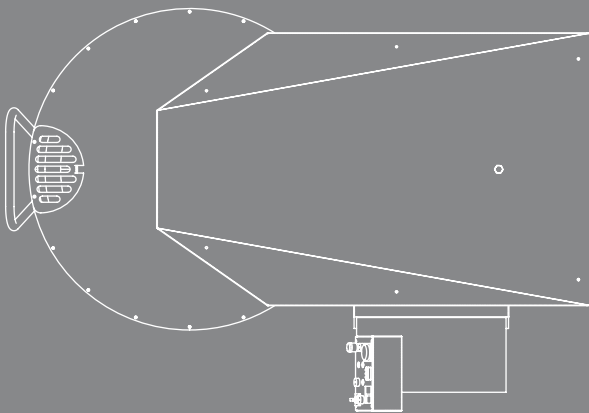

1,612.5

2,351.1

Dimensions in mm.

	Gewicht					
	P 75	P 100	P 125	P 150	P 200	P 250
Machine and bowl	650	1,200	1,200	1,100	2,500	2,500
Additional bowl	120	180	180	180	350	350

PRESENTATION SELLS



WP BAKERYGROUP

 **Werner & Pfleiderer**
Bakery Technologies

 **Werner & Pfleiderer**
Industrial Bakery Technologies

 **Werner & Pfleiderer**
Bakery Cooling

 **Werner & Pfleiderer**
Instore Baking

 **Werner & Pfleiderer**
Bakery Service

 **Werner & Pfleiderer**
Bakery Consulting

 **Haton**

 **Kemper**

 **Winkler**

 **BackNet**
Bakery Software

Agencies with Service Departments
can also be found in all regions of
the world.