

OPTIMA PTO

PALLET TRUCKS WEIGHER



INTEGRATED INDICATOR
WITH PROTECTION
*Printer version



ERGONOMIC HANDLEBAR
EASY TO USE

Quality design and finish, with a friendly use. Dust paint for maximum duration. Easy operation with multifunction indicator and LCD display.



PTO PALLETTRUCK TOWER OPTIMA



PCS



PRINT INC



BAT INT



AC/DC



IP54



NO VERIF

Pallet Trucks Weigher

FEATURES:

- Weighing pallet truck.
- Structure in powdered painted steel.
- Wheels of nylon.
- 2 versions:
 - No printer
 - With printer

INDICATOR:

- LCD screen
- ABS housing, with steel impact protection part.
- P54 protection.
- Units kg and lb.
- Rechargeable internal battery 6V 4,5Ah.
- Power supply with adaptor AC/DC 100-240Vac 50/60Hz.
- Operating temperature -10°C a 40°C.

FUNCTIONS:

- Accumulation
- Zero
- Tare
- Gross/ Net
- Piece counting function
- Checkweighing function
- Hold function
- Weight for percentage

PRINTING:

- Printer version gives the ticket tare, brut and net.
- With date and time.



MAXIMUM HEIGHT OF 205 mm

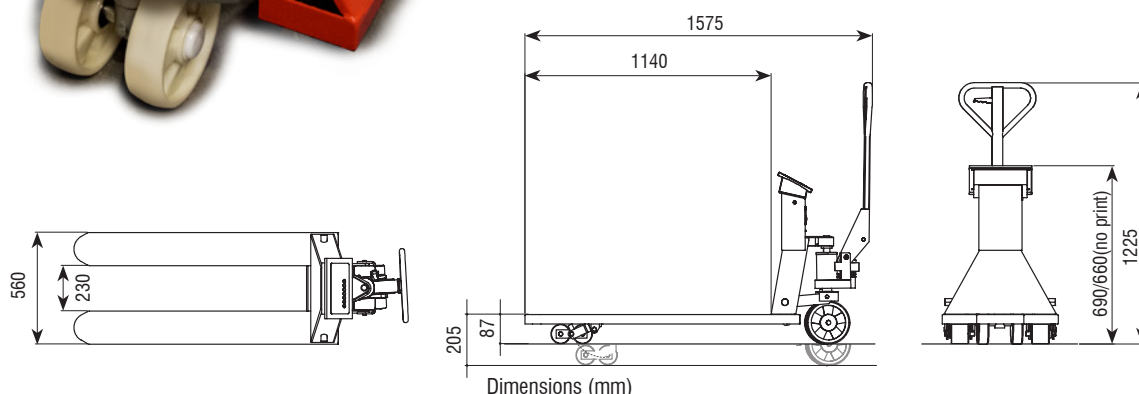

Code#	Capacity (kg)	Readout (g)	6-unit pack disassembled	Printer	Packing dimensions (mm)	Packing weight (kg)
261504	2000	500			1600x600x800	94
261505	2000	500		•	1600x600x800	94
261514	2000	500	•		2300x624x1000	589
261515	2000	500	•	•	2300x624x1000	589