

# TR740 - "The Best-Seller"

## Multiple use rammer

A rammer with a rugged design for multiple uses. This rammer is suitable for applications on both granular and cohesive soils, where strict requirements are imposed for compaction in confined areas, trenches and repair work.

## FEATURES AND BENEFITS

- Strong protective frame and engine support.
- Transports in any position.
- A unique three-stage air filtration system provides a virtually dust-free engine for longer life and improved durability.



POWERED by  
**HONDA**  
norm SAE J1349

Code	TR740H
Model	TR740
Operating mass (kg)	70
Centrifugal force (kN)	18,6
Plate width (mm)	335 - 285
Engine	Honda GX120
Power hp (kW)	4,0 (2,94)
Speed (m/min)	9 - 12
Amplitude (mm)	65 - 75
Frequency (Hz)	12
Sound pressure level dB (A)	91
Vibration* emission value/(m/s <sup>2</sup> )	4,9
Percussion rate max. (Blows/min)	690
Operating speed (m/min)	7,5
Surface capacity - Compaction (m <sup>2</sup> /h)	123

\* Minimum vibration levels measured to EN500-4

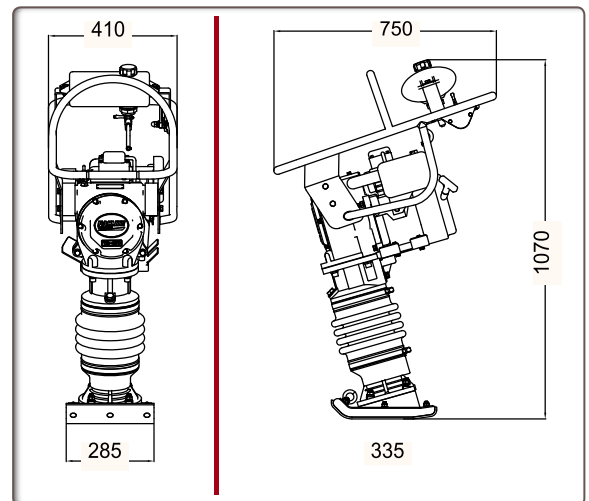

Perfectly balanced rammer with high stroke



Oil level gauge



Wood laminated foot



**Wheel kit OPTION**  
Code OP/TR-WHEEL