

# PC60

## A Premium asphalt plate with moulded base plate for various applications

PACLITE PC60 feature a tough, wear resistant, ductile iron base plate offering high strength and shock resistance. This computer designed base plate has a tapered bottom and edges for high speed and excellent manoeuvrability.

Designed for the compaction of granular and mixed materials with some cohesive content in confined areas such as parking lots, highway and bridge construction, next to structures, curbs, and abutments.

## FEATURES AND BENEFITS

- Special contoured running surfaces and rounded edges provide maximum performance and manoeuvrability.
- Completely enclosed belt protected by a lightweight belt guard for reduced wear and minimal service.
- Newly designed "low-vibration" guide moulded handle due to the 'cup design' greatly improves operator comfort and minimizes operator fatigue.
- Heavy-duty shock mounts on engine console dampen vibrations thereby reducing wear on the components.
- Exciter bearing design requires minimal maintenance for improved productivity.
- Standard package Honda GX160 water kit and transport wheels.
- Low HAV mechanism.
- Throttle mounted on the operating handle.

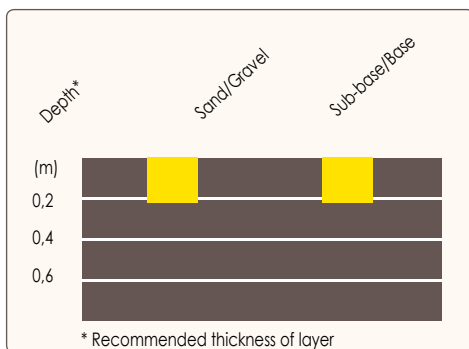
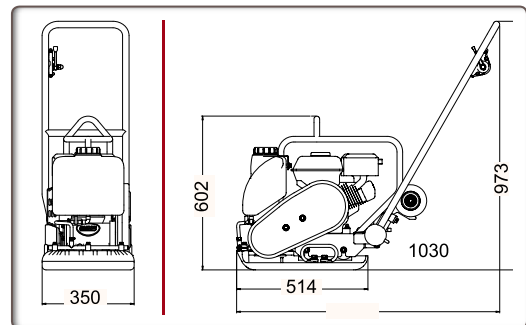

Perfectly balanced and designed for the toughest job sites.



95 Hz



20°



11 kN



20 m/mn



Low HAV mechanism

Code	PC60H
Model	PC60
Operating mass (kg)	66
Centrifugal force (kN)	11
Plate width (mm)	350
Engine	Honda GX160
Power hp (kW)	3,5 (2,6)
Water tank (L)	8
Speed (m/min)	20
Amplitude (mm)	0,9
Frequency (Hz)	95
Sound pressure level dB (A)	88
Vibrations (m/s <sup>2</sup> ) *	3,9
Surface capacity (m <sup>2</sup> /h)	630

\* Minimum vibration levels measured to EN500-4



OPTION : PAVING PAD

Code PPV-PAD60