

# IMPACT 320 / IMPACT 430 - "Triple Bull"

## Reversible plate

The most modern and compact design with increased speed to allow greater compaction capacity and is designed to meet the toughest job conditions. PACLITE compact series forward/reverse vibratory plate with excellent compaction data.

Speed and compaction depths are regulated seamlessly via hydraulic servo control of the excentric element. This gives the plate smooth motion and makes it very easy to operate. All-round plates for compaction work close to piles and concrete bases. Also for floor filling and foundations as well as backfill in pipe trenches.

## FEATURES AND BENEFITS

- Increased forward travel speed for greater surface capacity.
- The same forward and reverse speed produces more consistent results, E.G. in plaster compaction.
- Reinforced covers and fastening elements for increased protection and thus lower maintenance costs.
- The moulded bottom plate is made of wear resistant steel GJS-700.
- Long operating times thanks to low hand-arm vibrations.
- Lifting point.
- Engine with oil alert on all models.
- The handle can be positioned vertically for better manoeuvrability.
- Optimized rubber shock mounts reduces hand-arm vibrations transmitted to the operator.
- Loading to trucks or placement in trenches are facilitated by a strong lifting eye.
- Stop alarm engaged when engine is on stop.



Manual dual starter



Electric start



Low HAV handle with rubber mounts and servo control



Electric version

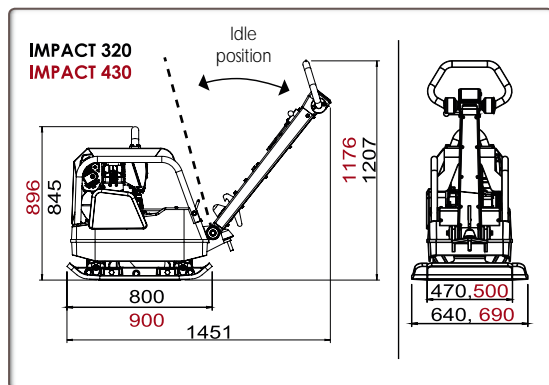

Code	IMP320DHES	IMP430DE
Model	IMPACT320	IMPACT430
Dimensions L x W (mm)	1494 x 640 x 1218	1671 x 690 x 1153
Operating weight (kg)	320	438
Centrifugal force (kN)	42	50
Working width (without extensions) (mm)	470 + 2 x 85	500 + 2 x 95
Thickness of bottom plate (mm)	12	12
Operating speed (m/min)	23	26
Compacted area (m <sup>2</sup> /h)	792	912
Frequency (Hz)	70	80
Engine	Hatz diesel 1B30	Hatz diesel 1B40
Engine power hp (kW)	7,3 (5,4)	10 (7,5)
Power (rpm)	2900-3600	2900-3600
Engine consumption (l/h)	1,5	1,8
Engine single cylinder	Air-cooled	Air-cooled
Start	Electric and auxiliary rope	Electric and auxiliary rope
Automatic cut-off in case of lack of oil	Yes	Yes
Hand-arm vibration (EN500-4) (m/s <sup>2</sup> )	3,1	3,1
Vibrations* m/s <sup>2</sup> /utilisation (hrs)	3,2/4,53	3,2/4,53

\* Minimum vibration levels measured to EN500-4

COMPACTION

MOBILE EQUIPMENT

CONCRETE EQUIPMENT

SURFACING

CUTTING - GRINDING