

Application note: rolls005

Stand-alone packaging of nonwoven rolls

XL Simplex S1-L

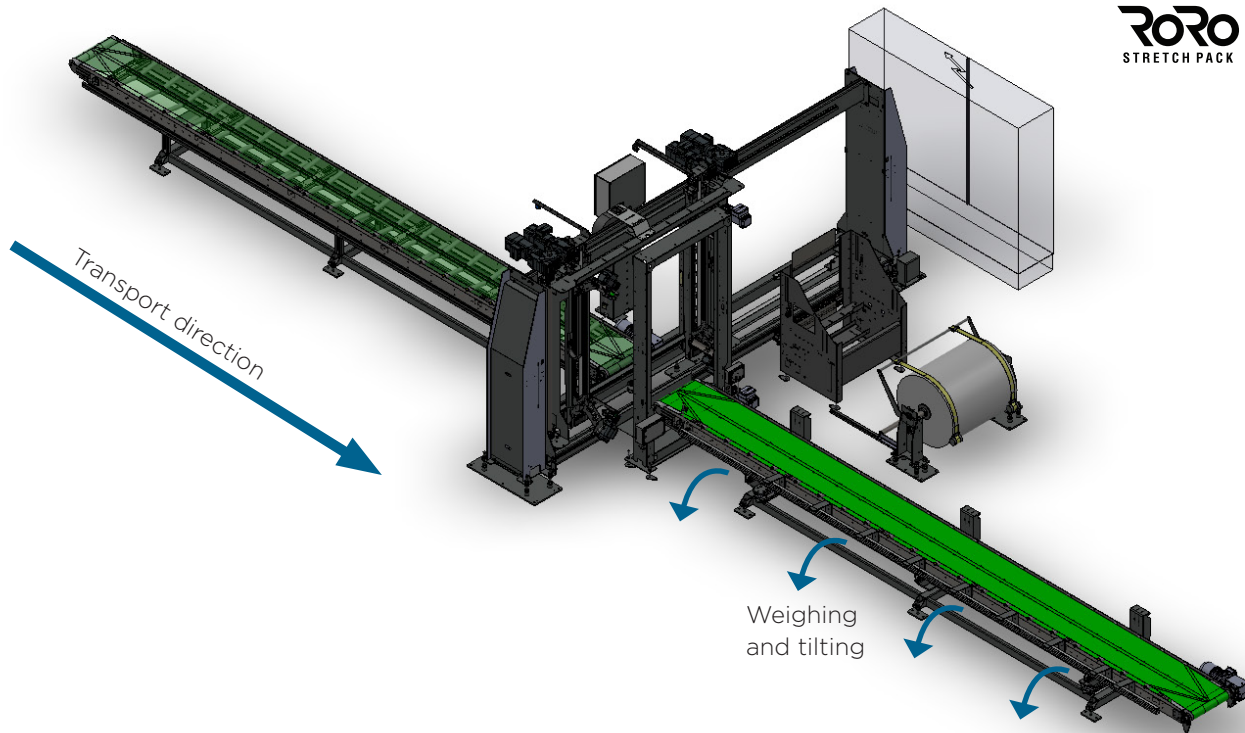

Stand-alone packaging solution for nonwoven rolls

This RoRo StretchPack® solution is for packaging of nonwoven rolls with lengths from 1250 mm and up to 8000 mm. The roll diameter is between 200 mm and 1350 mm. Depending on the roll variance, more than one film stand might have to be installed. The rolls are packed in a tubular stretch film, with sealings in each end for 100% waterproof packaging. It is possible to pack different roll sizes in random order.

Infeed and outfeed are V-shaped belt conveyors with a non-slippery surface. There are weighing and tilt functions built into the outfeed conveyor. It means that after packaging, the roll is weighed and then tilted away from the conveyor for further handling.

With roll lengths of 1250-8000 mm the packaging capacity is estimated at 50-185 packs per hour in this specific customer application*. The film unit can be equipped with semi-flow function for increased packaging speed*).

After back sealing, the end snip of the film is cut off the roll. It is an option to remove the film cut by a vacuum unit.

Features and benefits

- Fully sealed roll packaging
- Outfeed conveyor with tilt and weighing function
- High uniformity and repeatability
- Automatic packaging and sealing in one operation
- Automatic packaging multiple product sizes
- Energy-saving technology - replaces heat shrink
- Film reductions by up to 60%
- Roll size:
 - Ø: 200 - 1350 mm
 - L: 1250 - 8000 mm
 Depending on the roll variance, more than one film stand might have to be installed.
- High uptime - reduced number of film roll changes
 - Up to 8 km of PE-film per film roll ø800 mm at 30µ,
 - Up to 12 km of PE-film per film roll ø1000 mm at 30µ,
- Packaging with PE-film thickness 30-120µ

Stand-alone packaging of nonwoven rolls XL Simplex S1-L

Machine specifications

- Main Frame S1 XL (110-10031)
- Film Unit XL (100-10015)
- Gripper Unit XL (110-10132)
- Back Sealing Unit L (100-10014)
- Film stand (110-10085)
The number of film stands depends on the roll variance.
- Infeed conveyor (105-10017)
- Outfeed conveyor incl. tilt and weight measurement (105-10018)
- Electrical cabinet with HMI

