

MONTAGE HANDLEIDING  
NOTICE DE MONTAGE  
MOUNTING INSTRUCTION  
MONTAGE ANWEISUNG

# VERSUZ

Artikelnummer: 063563

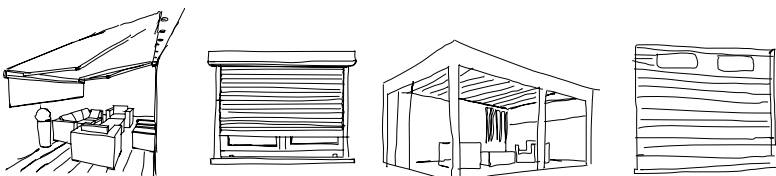

**HAROL®**



## NEDERLANDS

### Algemene informatie

Beste klant, dank u voor uw keuze van een HAROL overkapping "VERSUZ".

Onze onderneming heeft ervoor gekozen om te investeren in kwaliteit en innovatie, door zowel de materialen als de productieprocessen te selecteren en te perfectioneren.

OPGELET: Leest u, voordat u de zonwering gebruikt, aandachtig alle waarschuwingen en instructies in deze handleiding en in de handleiding met gebruiksinstructies voor. Deze handleidingen zijn onderdeel van het product en moeten voor toekomstig gebruik bewaard en altijd ter beschikking worden gehouden, zolang de zonwering niet wordt afgedankt.

### Opmerkingen

De installatie moet worden uitgevoerd door gekwalificeerd personeel in overeenstemming met de IEC-normen en de nationale bepalingen inzake civiele elektrische installaties.

Raadpleeg ook de technische fiche

! Lees deze handleiding vooraf zorgvuldig door.

! Door het opspannen van de veren ontstaan er grote krachten. Ga voorzichtig te werk. Zorg dat u stevig staat.

! Zorg voor een montageruimte met voldoende licht. Verwijder obstakels en vuil. Zorg ervoor dat er geen andere personen dan monteurs aanwezig zijn. Onbevoegden kunnen in de weg lopen of gevaar lopen tijdens de montage.



Dit symbool duidt op mogelijk gevaar voor personen of schade aan het product.



Dit symbool geeft "Opgelet" aan.



Dit symbool geeft het gebruik van kracht aan om de aangegeven werkzaamheid te verrichten.

Wanneer u elektrische schroevendraaiers gebruikt, stelt u dan de juiste koppelwaarde in.



Dit symbool geeft aan dat er een visuele controle dient uitgevoerd te worden



Dit symbool geeft een optioneel toebehoren aan.

De fabrikant is niet aansprakelijk voor eventuele onjuistheden te wijten aan druk- fouten die in deze handleiding kunnen aanwezig zijn. Hij behoudt zich het recht voor om nodige of voor de gebruiker nuttige wijzigingen aan zijn producten door te voeren, zonder afbreuk te doen aan de functionaliteit en de veiligheid.

Geen aanpassingen aan design en configuratie zonder consultatie van fabrikant.

De gebruikershandleiding moet overhandigd worden aan de eindgebruiker.



## ENGLISH

### General Information

Dear Customer, thanks for having chosen a HAROL cover "VERSUZ".

Our company has been designing and producing sun awnings since 1960. since our very beginning we have chosen to invest on quality and innovation, selecting and improving both the materials used and the productive processes.

WARNING: before using the awning, read carefully this instructions manual and also the one called "Instructions Manual". This manuals are part of the product and must be properly stored for any future need until the awning disposal.

### Warnings

Installation must be carried out by qualified personnel in compliance with EN and local safety regulations relative to domestic electrical systems.

See also product technical data document.

! Before you start ,please do read these instructions thoroughly.

! The tightening of springs creates important powers. Be very careful and make sure of a solid footing whilst operating.!

Provide sufficient light in the fitting area. Dispose of obstacles and dirt. Make sure that, except for the fitters, no other people are in the fitting area. Unauthorized people might be in the way or at risk themselves.



This symbol indicates the possibility of injury to persons or damage to the product.



This symbol means "Warning".



This symbol means to use force during the shown operation.

Using electric screwdrivers set the correct torque value.



This symbol means the need of a visual control.



This symbol indicate a particular which is given as optional.

The manufacturer accepts no liability for any inaccuracies or printing errors that may be contained in this manual. The manufacturer reserves the right to introduce any modifications to the product that are considered necessary or in the interests of the user and which do not alter the essential operational and safety characteristics of the appliance.

No modification of the design or configuration without consulting the manufacturer.

The instruction of use shall be provided to the end user.



## FRANÇAIS

### Informations Générales

Cher Client, merci d'avoir choisi une structure HAROL "VERSUZ".

Notre société conçoit et produit des stores pare-soleil depuis 1960 ; dès le départ, nous avons choisi d'investir sur la qualité et sur l'innovation, en sélectionnant et en perfectionnant tant les matériaux que les processus de fabrication.

ATTENTION : avant d'utiliser le store, lire attentivement tous les avertissements et les instructions figurant dans ce manuel et dans le manuel "Manuel d'utilisation".

Ces manuels font partie intégrante du produit et ils doivent être conservés et être toujours à disposition pour toutes consultations futures, jusqu'à l'élimination du store.

### Avertissements

L'installation doit être effectuée par du personnel qualifié conformément aux normes NF et aux dispositions nationales relatives aux installations électriques civiles.

Voir aussi la fiche technique

! Commencez par lire attentivement cette notice!

! La tension des ressorts crée une force importante. Procédez avec précaution. Positionnez-vous de manière stable.

! Veillez à ce que le lieu de montage soit suffisamment éclairé. Débarrassez-vous des obstacles et des crasses. Assurez-vous qu'il n'y a personne d'autre que les monteurs. Des personnes incompetentes pourraient vous gêner ou courir un danger pendant le montage.



Ce symbole indique un risque de danger pour les personnes ou de dommage à le produit.



Ce symbole indique: «Attention».



Ce symbole vous indique d'utiliser de la force au cours de l'opération.

Si on utilise un visseuse électrique il faut définir la valeur de couple correcte pour le serrage.



Ce symbole vous indique qu'il faut effectuer un controle visuel.



Ce symbole vous indique un accessoire en option.

Le fabricant décline toute responsabilité pour les éventuelles inexactitudes imputables à des erreurs d'impression ou de transcription contenues dans cette notice. Il se réserve la faculté d'apporter à ses produits toutes les modifications qu'il estime nécessaires au utiles, y compris dans l'intérêt des utilisateurs, sans modifier leurs caractéristiques essentielles de fonctionnalité et sécurité.

Aucune modification de conception ou de configuration sans consultation du fabricant.

L'instruction d'utilisation doit être fournie à l'utilisateur final.



## DEUTSCH

### Allgemeine Hinweise

Sehr geehrter Kunde, vielen Dank für die Wahl eine HAROL Abdeckung "VERSUZ".

Unsere Firma entwirft und produziert Markisen seit 1960; vom Anfang an haben wir gewählt in Qualität und Innovation zu investieren, indem die Materialien wie auch die Produktionsvorgänge ausgewählt und verbessert wurden.

ACHTUNG: vor der Markisenbenutzung bitte alle Hinweise und Anleitungen in diesem Handbuch und im Handbuch "Bedienungsanleitung" sorgfältig lesen.

Diese Handbücher begleiten das Produkt und müssen sorgfältig aufbewahrt werden um für jede weitere Information griffbereit zu bleiben, bis die Markise entsorgt wird.

### Anmerkung

Die Installation ist von Fachpersonal und unter Beachtung der IECBestimmungen und der örtlichen Vorschriften bezüglich elektrischer Anlagen auszuführen.

Siehe auch die Technische Angaben.

! Lesen Sie die Anleitung vor der Montage sorgfältig durch!

! Durch das Spannen der Federn entstehen grosse Kräfte. Gehen Sie bitte vorsichtig vor und sorgen Sie dafür, dass Sie einen festen Stand haben!

! Sorgen Sie für ausreichend Licht auf der Montagefläche. Entfernen Sie Hindernisse und Abfall.



Dieses Symbol weist auf eine mögliche Gefahr für Personen bzw. Schäden am Produkt.



Dieses Symbol steht für "Vorsicht!"



Dieses Symbol bedeutet, Kräfteanwendung bei der Operationsdurchführung.

Wenn Sie Elektrische Schrauber benutzen, achten Sie bitte auf den korrekte Drehmoment.



Dieses Symbol bedeutet, dass ein visuell Steuerung angewendet werden muss.



Dieses Symbol kennzeichnet ein optionales Zubehör.

Für Unrichtigkeiten in diesem Handbuch, die auf Druck- oder Abschreibfehler zurückzuführen sind, übernimmt der Hersteller keine Haftung. Der Hersteller behält sich das Recht vor, alle für notwendig erachteten bzw. im Interesse der Abnehmer liegenden Änderungen an seinen Produkten vorzunehmen, ohne jedoch deren wesentliche Funktions- und Sicherheitseigenschaften zu beeinträchtigen.

Keine Änderung der Gestaltung oder Konfiguration der Ausrüstung ohne Rücksprache mit dem Hersteller.

Die Gebrauchsanleitung für den Endnutzer bereitzustellen ist.

# MONTAGE - MOUNTING VERSUZ

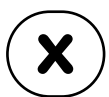
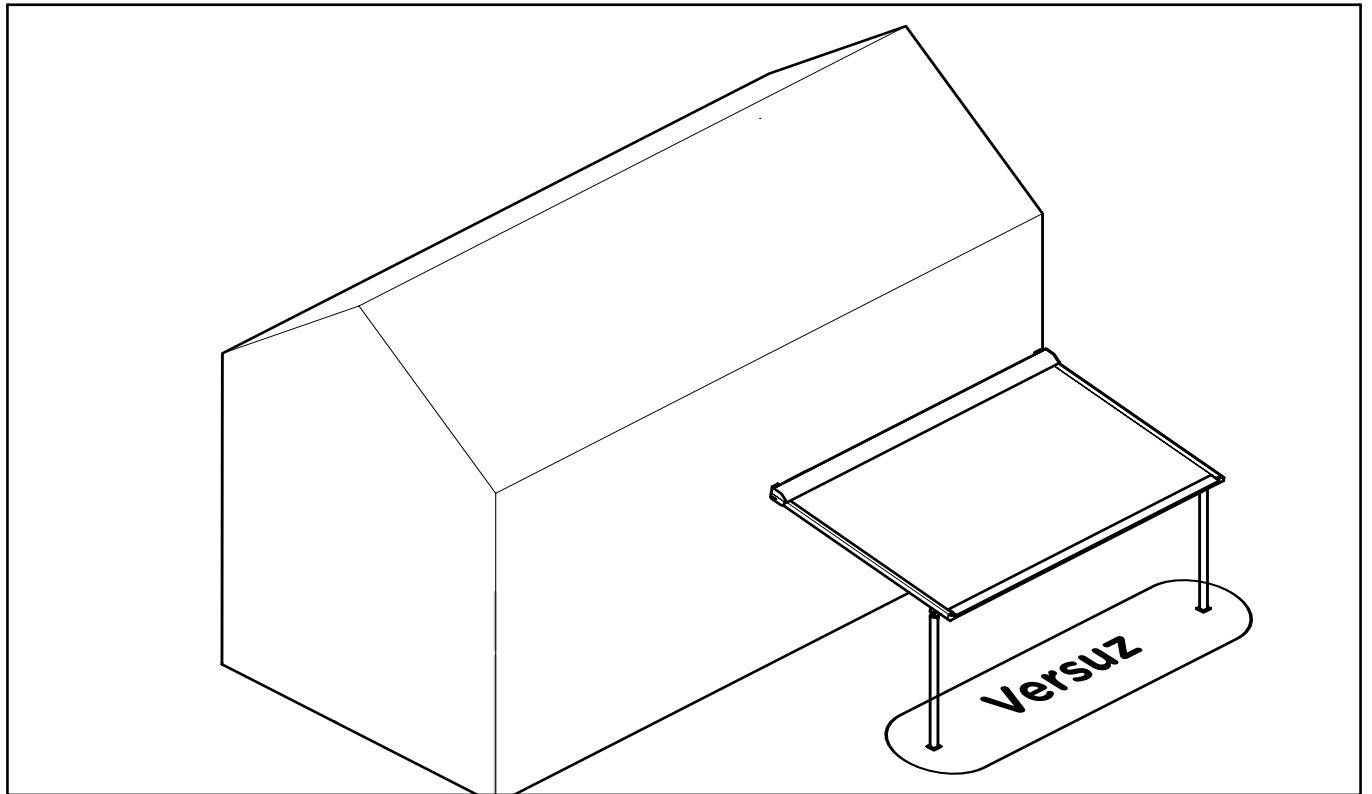
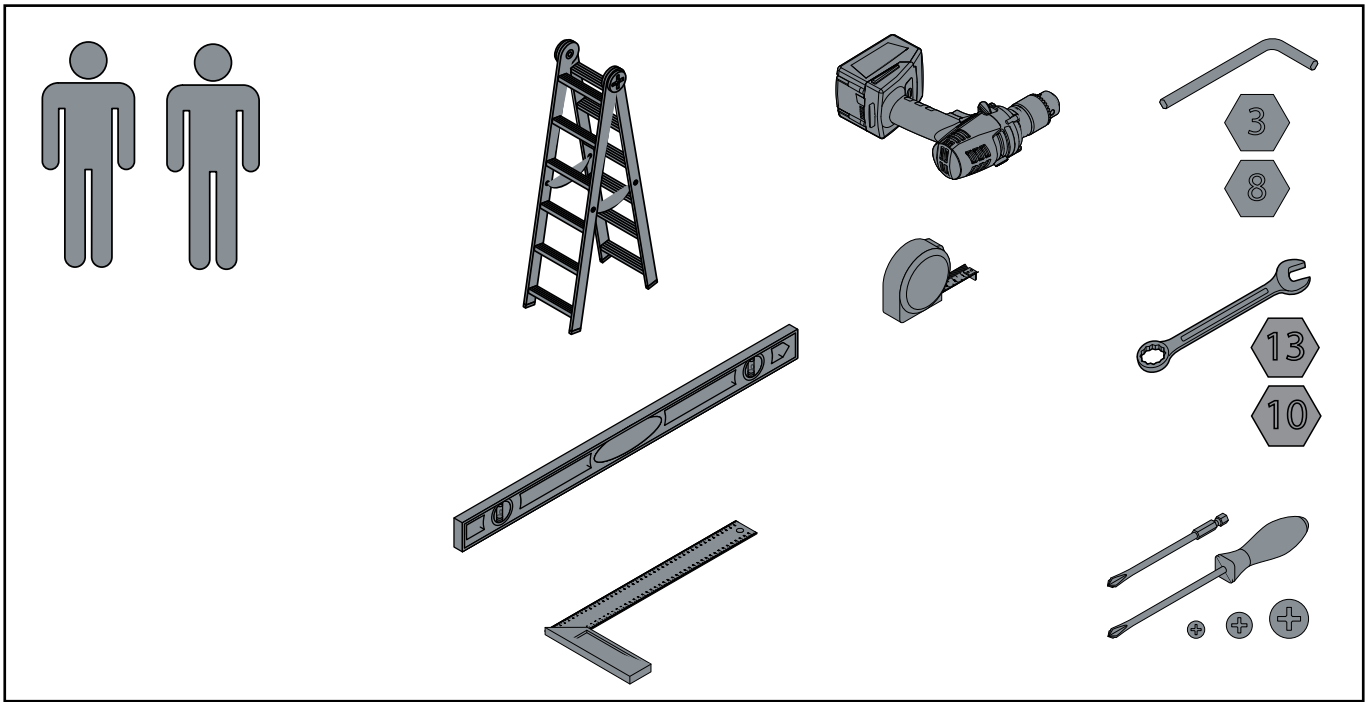

MONTAGESTAPPEN  
ETAPPES DE MONTAGE  
MOUNTING STEPS  
MONTAGESCHRITTEN



MONTAGESTAPPEN  
ETAPPES DE MONTAGE  
MOUNTING STEPS  
MONTAGESCHRITTEN



TUSSEN-STAPPEN  
ETAPPES INTERMEDIARES  
WITHIN-STEPS  
ZWISCHEN-SCHRITTEN

# VERSUZ



HOOGTE  
HAUTEUR  
HEIGHT  
HÖHE

H

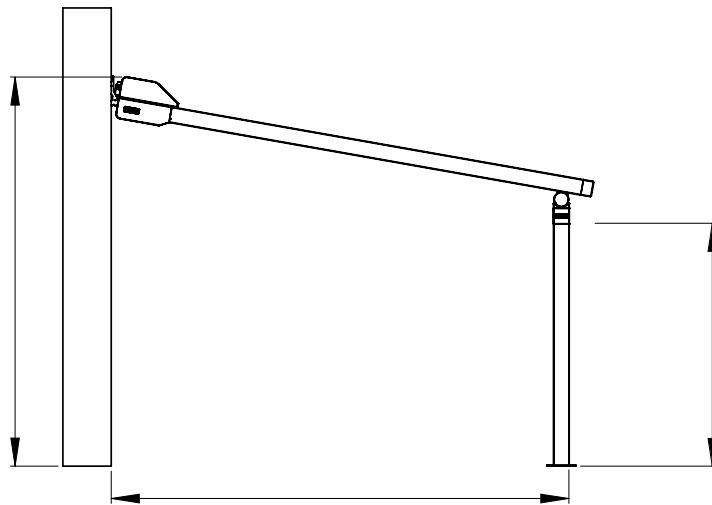

G

DOORLOOPHOOGTE  
HAUTEUR DE PASSAGE  
WALKTROUGH HEIGHT  
DURCHGANGSHÖHE

U

UITVAL  
PROFONDEUR  
SLOPE  
AUSFALL

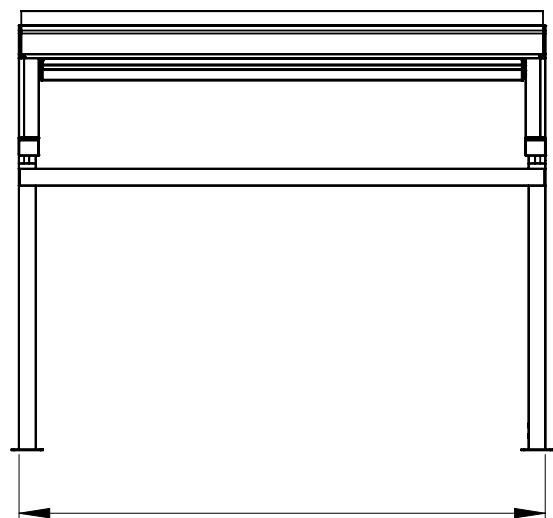

B

BREEDTE  
LARGEUR  
WIDTH  
BREITE



# MONTAGE - MOUNTING VERSUZ

1

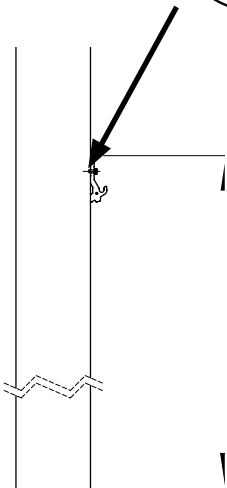
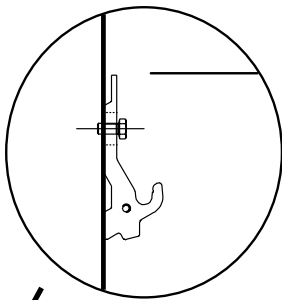
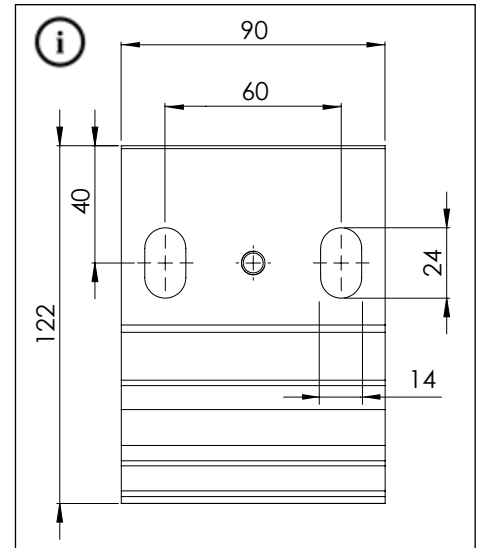
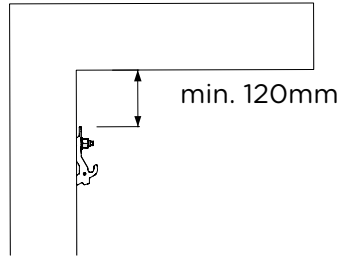
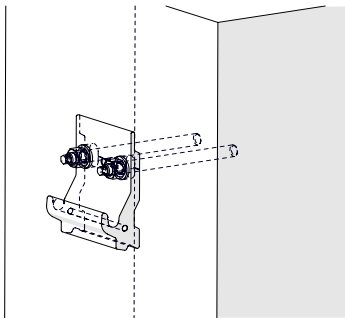
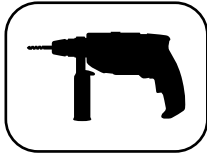

\*  
= (H) - 10 mm

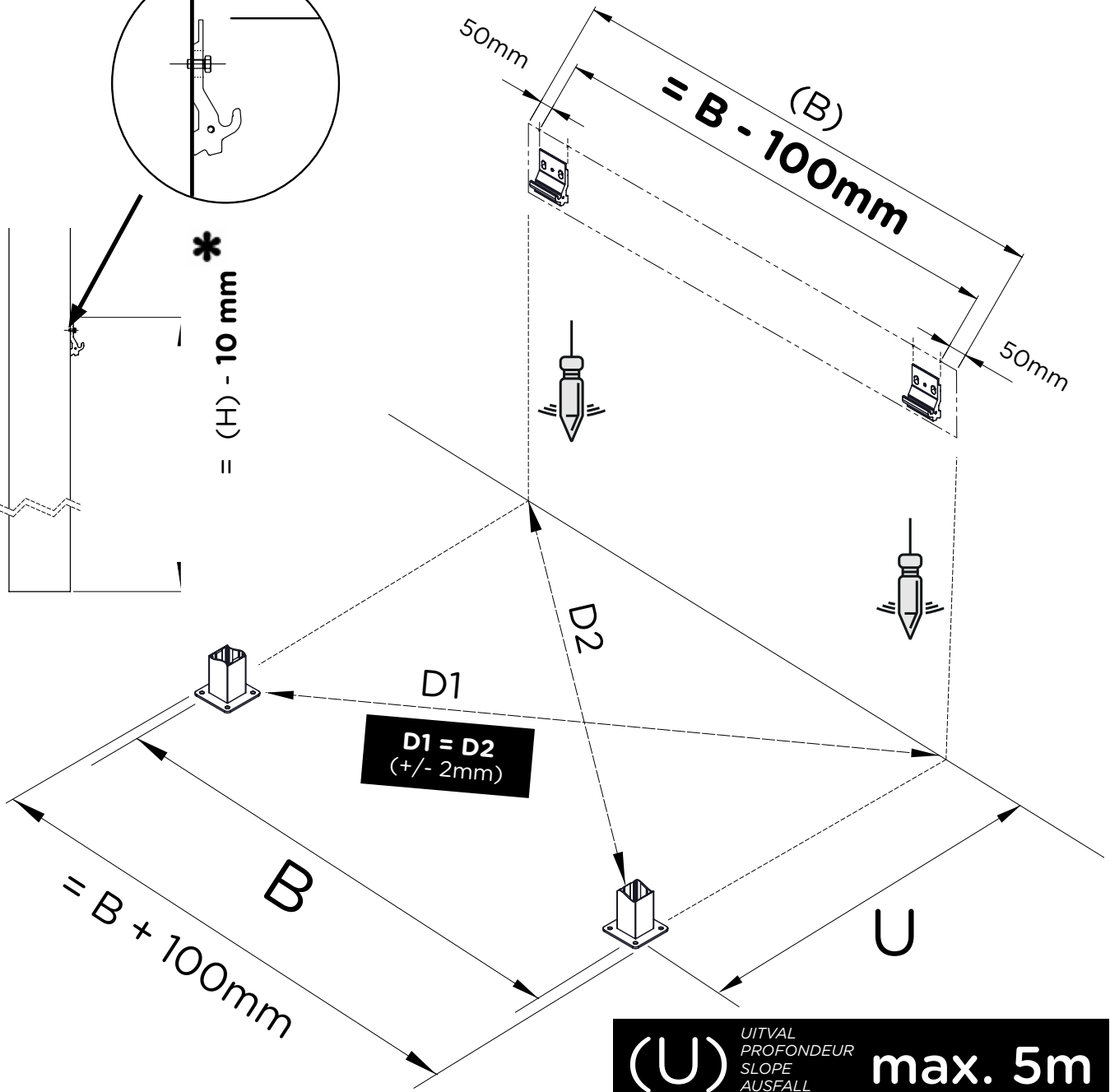

(U) UITVAL  
PROFONDEUR  
SLOPE  
AUSFALL **max. 5m**

OPTIE - MUURAANSLUITING  
 OPTION - RACCORD MURAL  
 OPTION - WALL INSERT  
 OPTION - MAUERANSCHLUSS

A1552

**1** OPTIE / OPTION

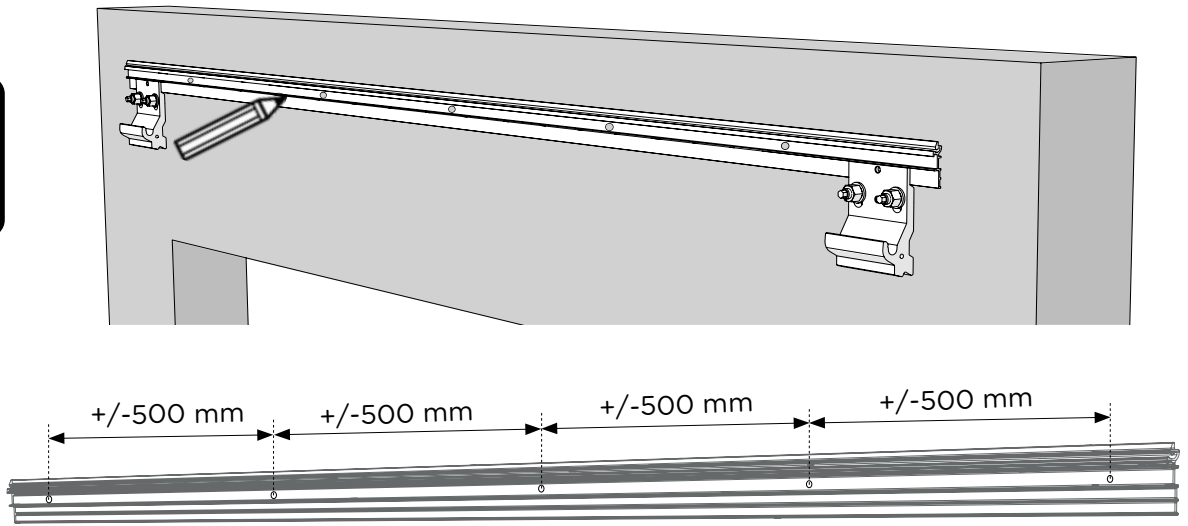
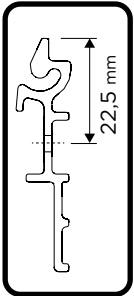

**2** OPTIE / OPTION

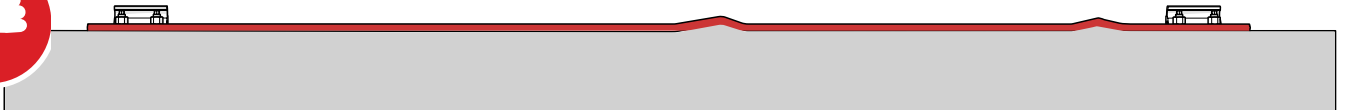
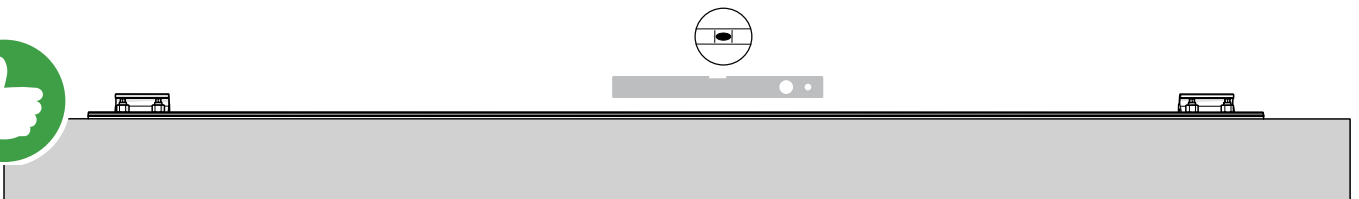
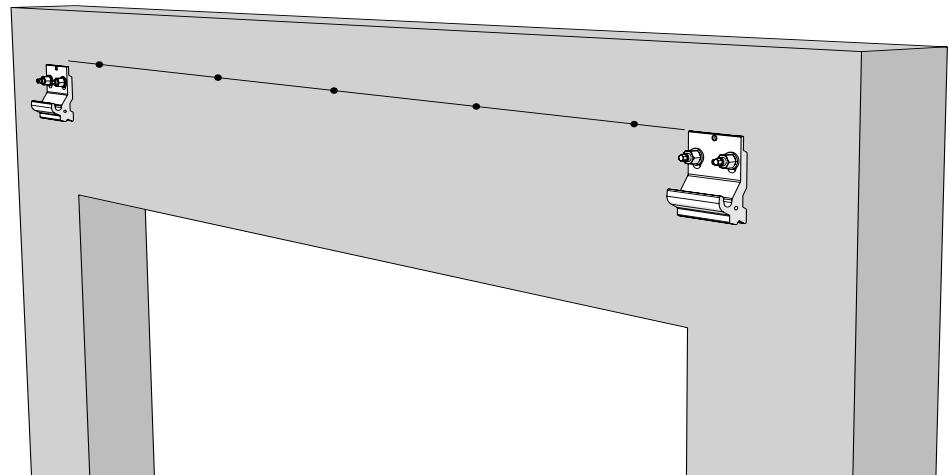
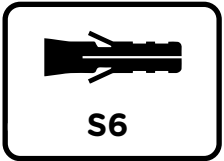
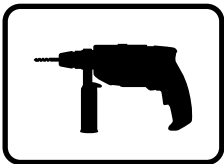

**3** OPTIE / OPTION

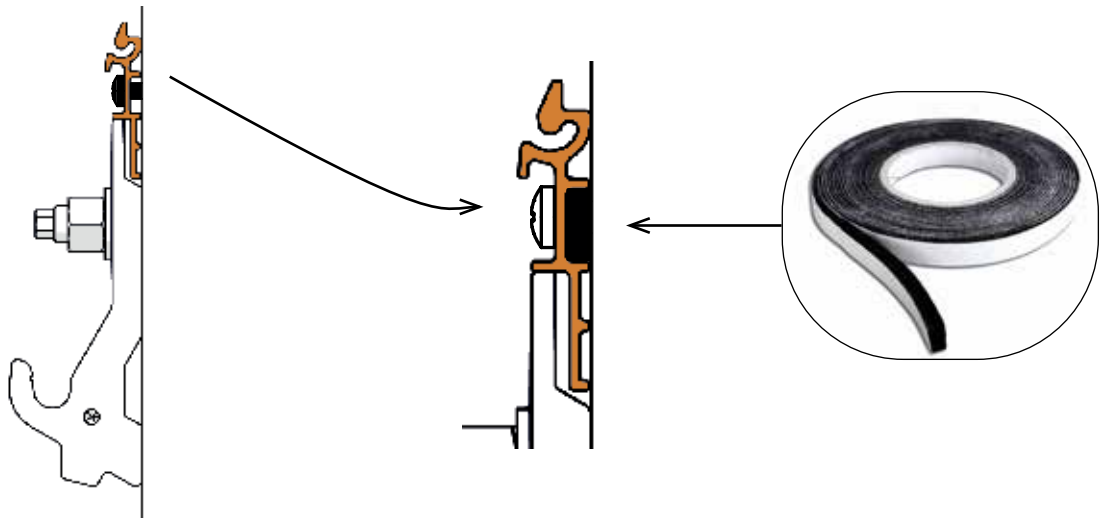
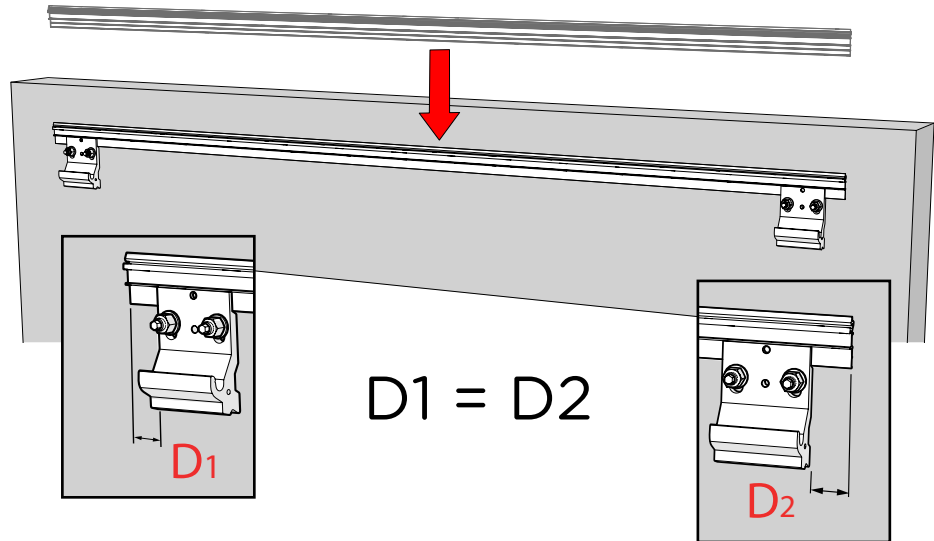
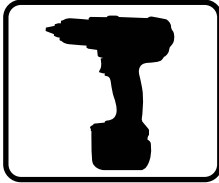
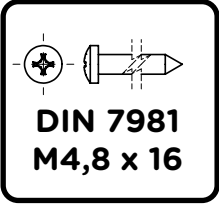

**4** OPTIE / OPTION

**TEST**

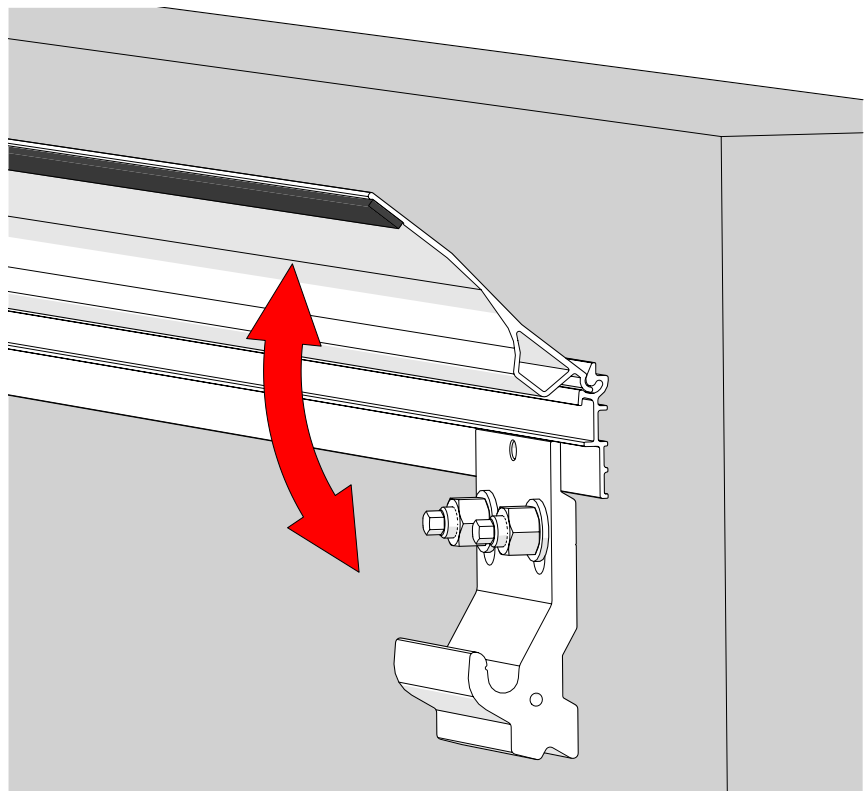
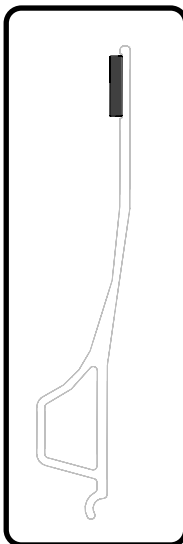

GEKOPPELD - COUPLE - LINKED - GEKOPPELT

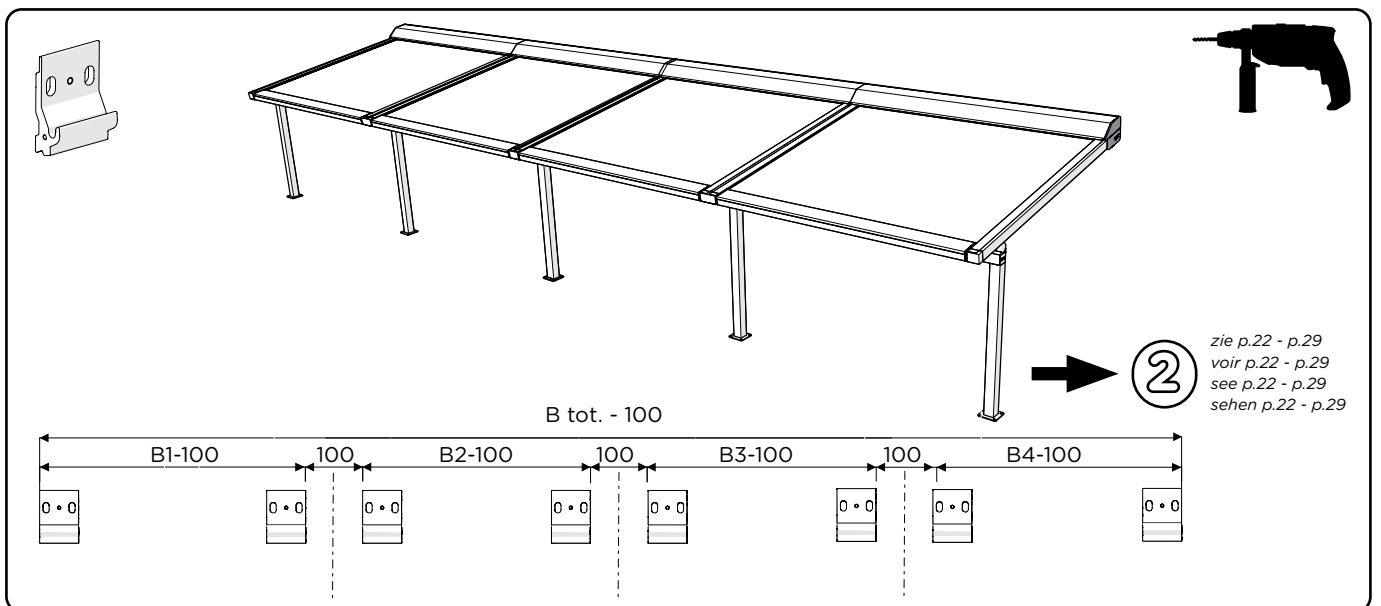
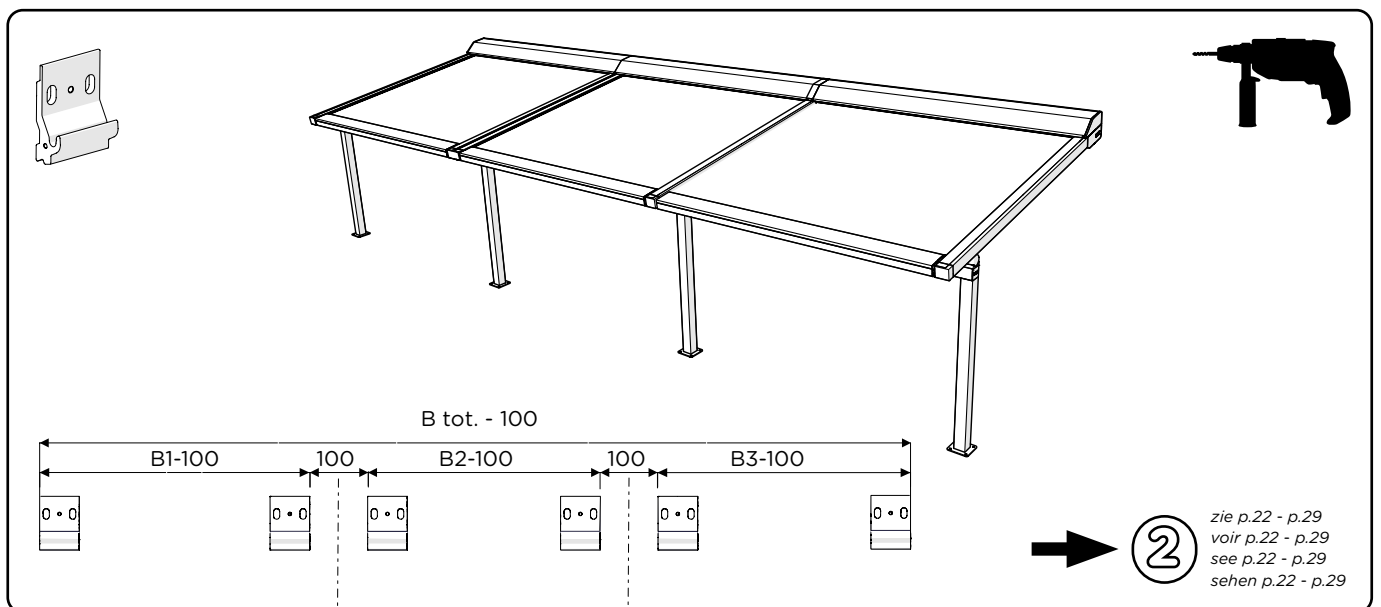
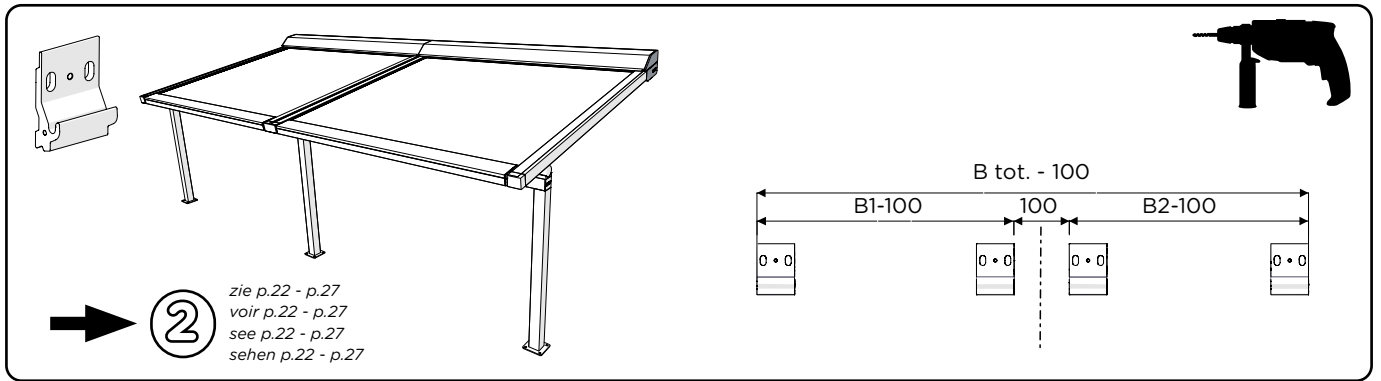

# MONTAGE - MOUNTING VERSUZ

2

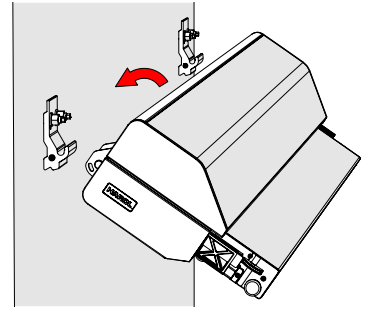
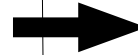
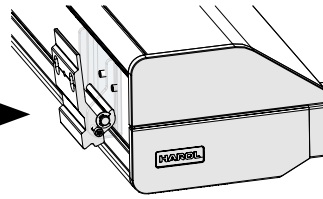
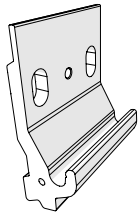

3

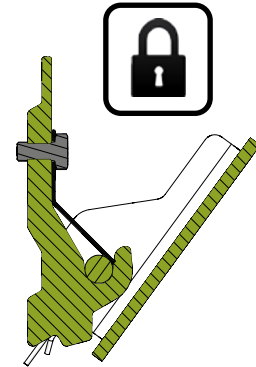
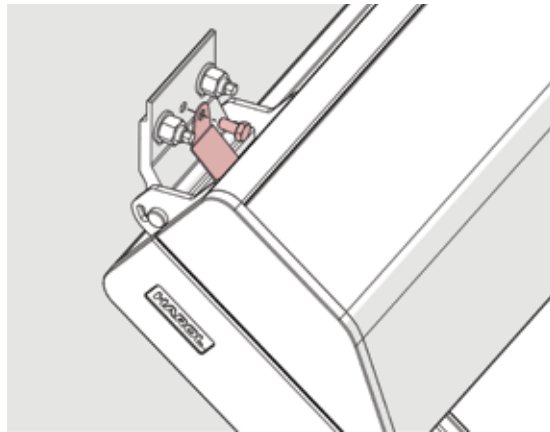
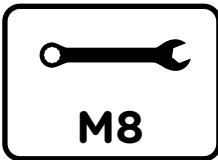
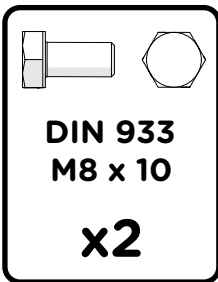

4

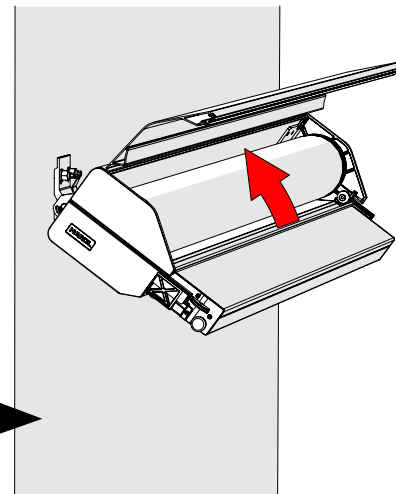
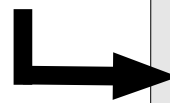
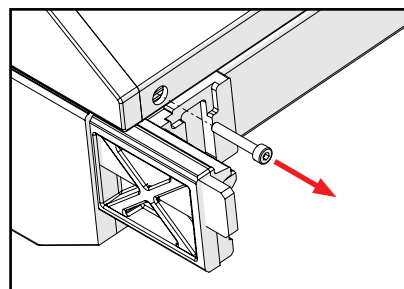
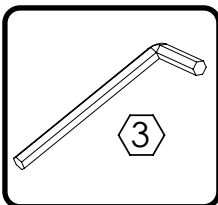
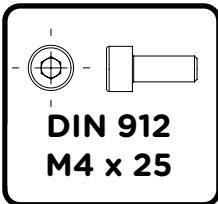

5

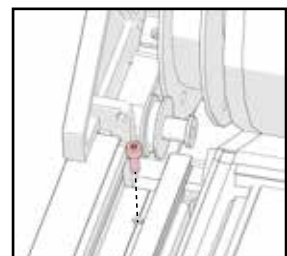
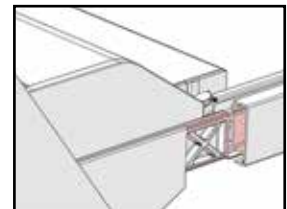
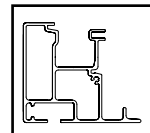
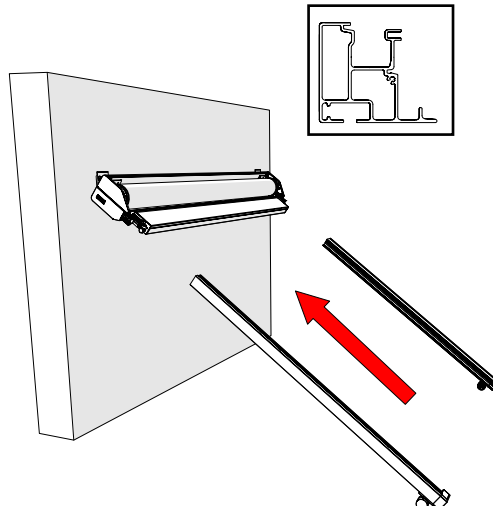
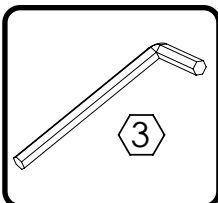
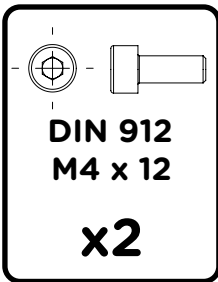

# MONTAGE - MOUNTING VERSUZ

6

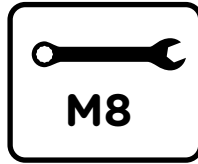
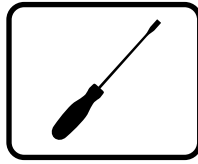
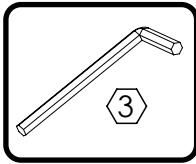

1	Din 7991 M4 x 12		2
2	Din 7981 4,8 x 13 mm		4
3	050905		2
4	DIN 933 - M10 x 35		2
5	050699		2
6	DIN 7982 4,8 x 19		8
7	050940		2

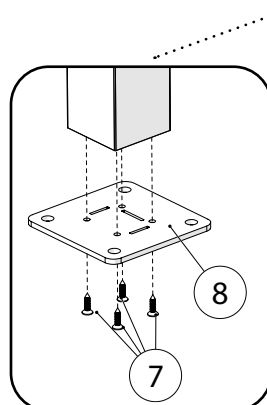
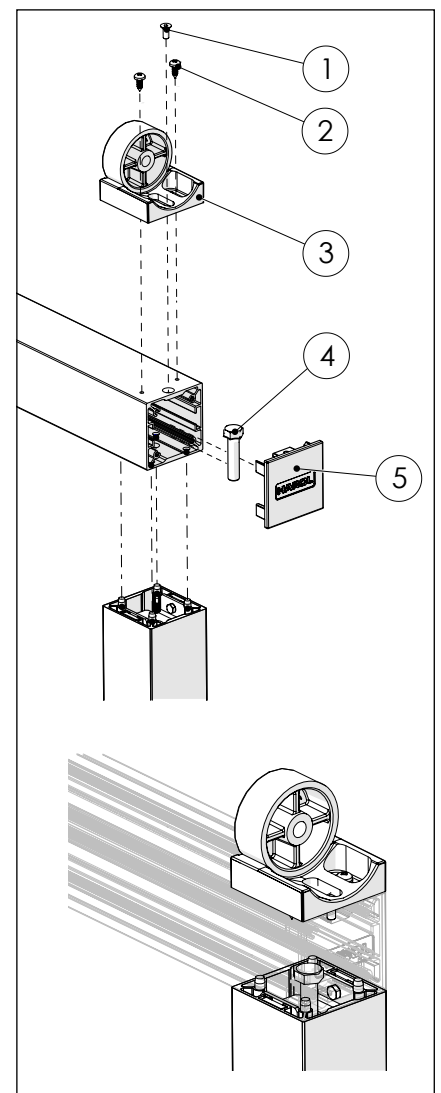
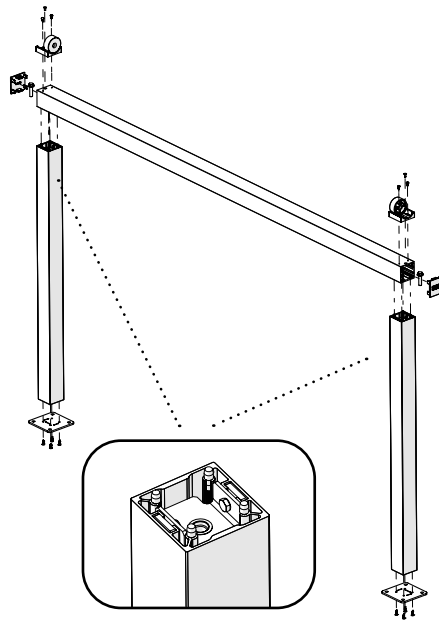
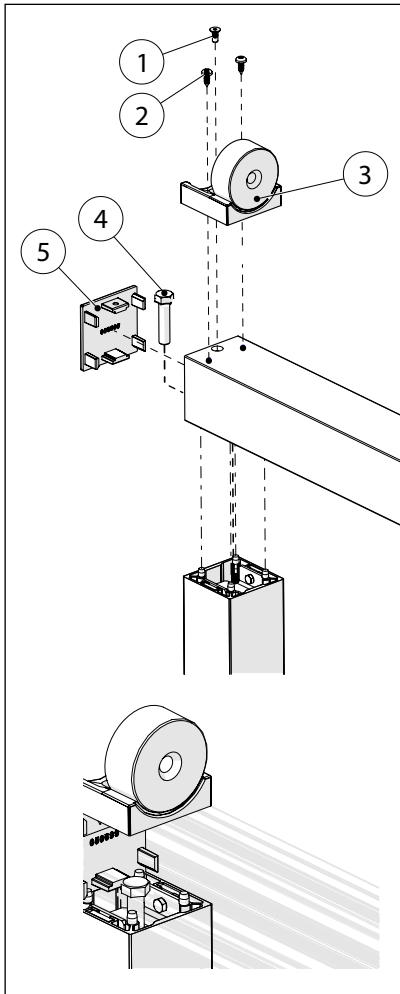

7

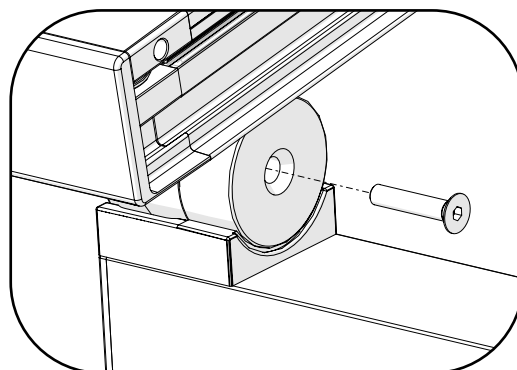
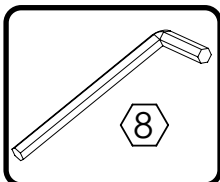
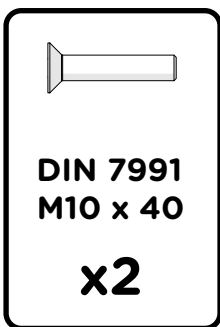
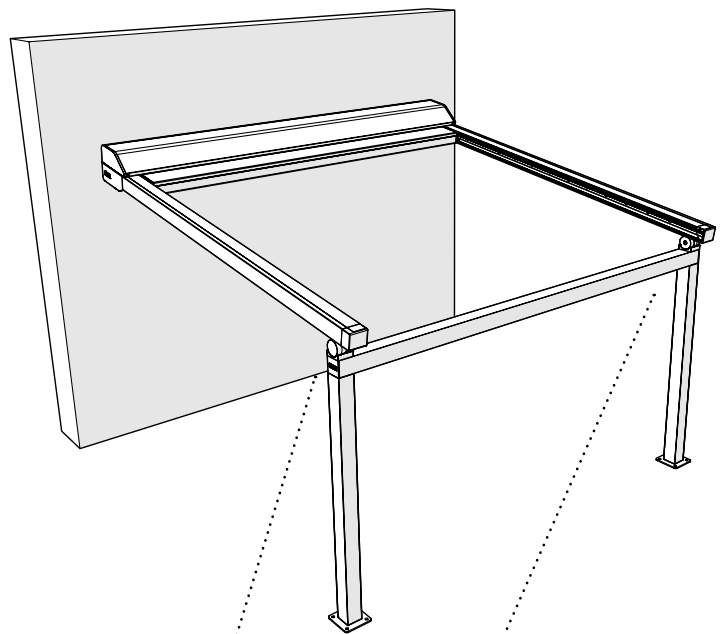
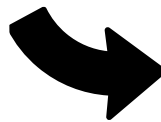
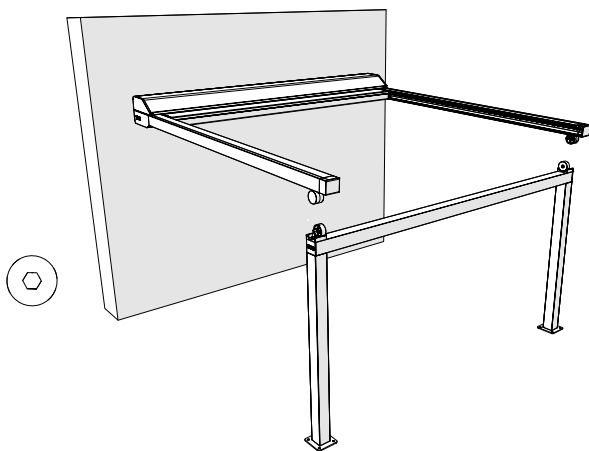
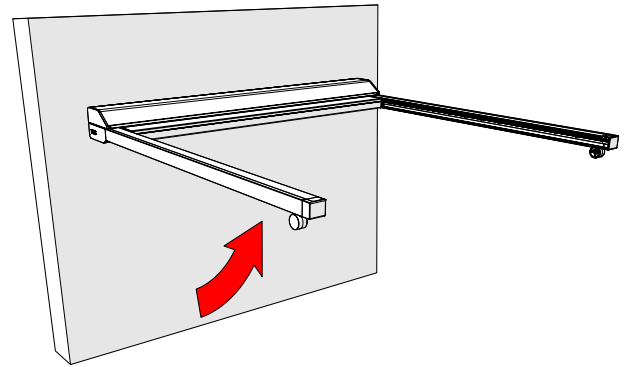
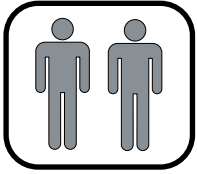

8

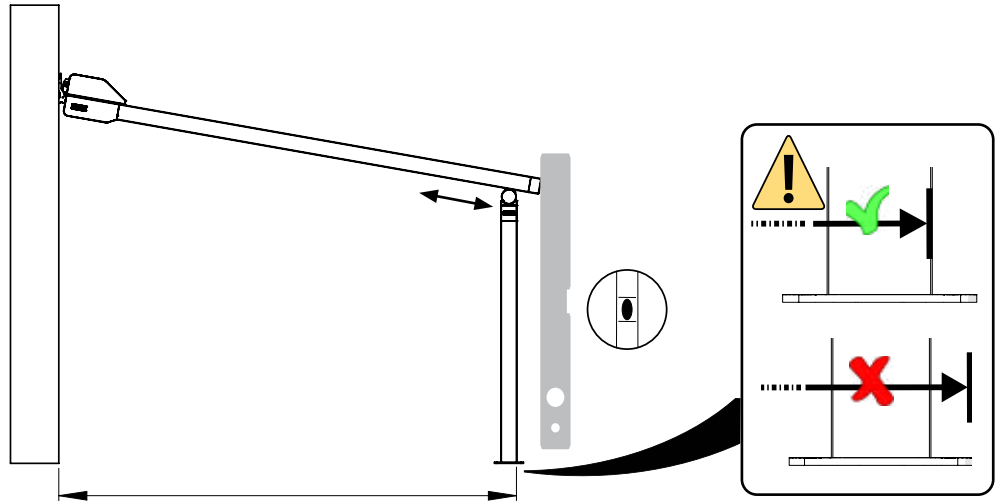
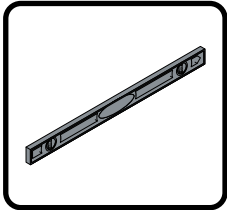
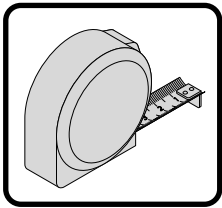

U

UITVAL  
PROFONDEUR  
SLOPE  
AUSFALL

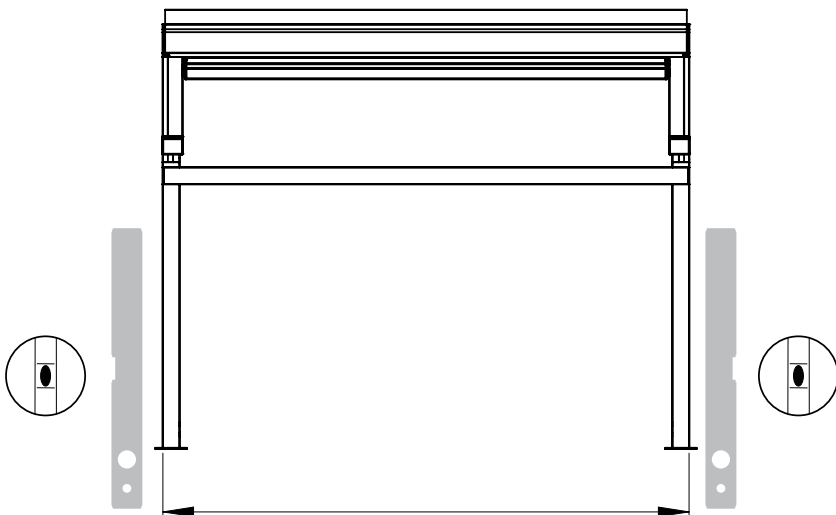

B

BREEDTE  
LARGEUR  
WIDTH  
BREITE

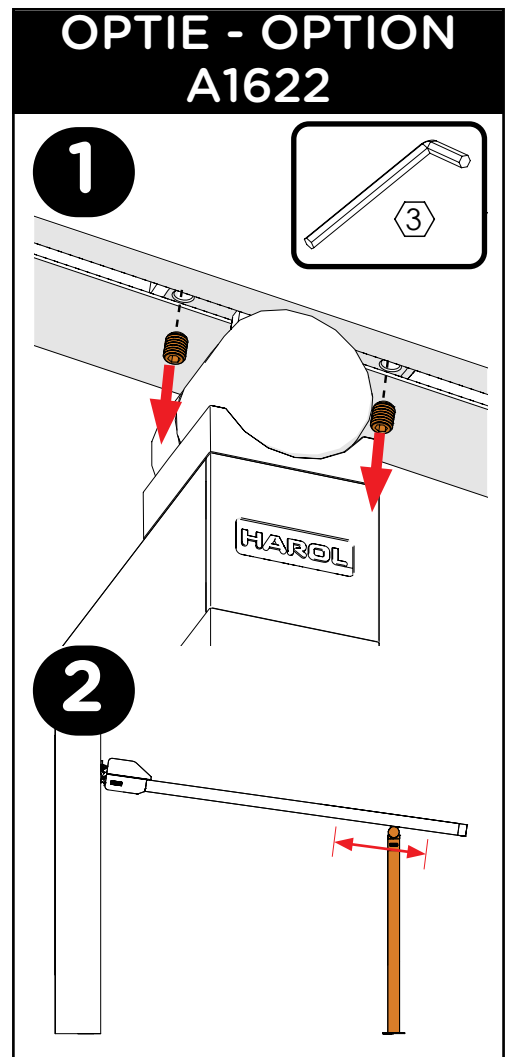

**VOETPALEN NOG NIET IN DE ONDERGROND VERANKEREN !  
NE PAS ENCORE FIXER LES PIED DANS LE SOL !  
DO NOT ANCHORE THE POSTS INTO THE GROUND YET !  
DIE PFAHLE NICHT JETZT IM BODEN VERANKERN !**



9

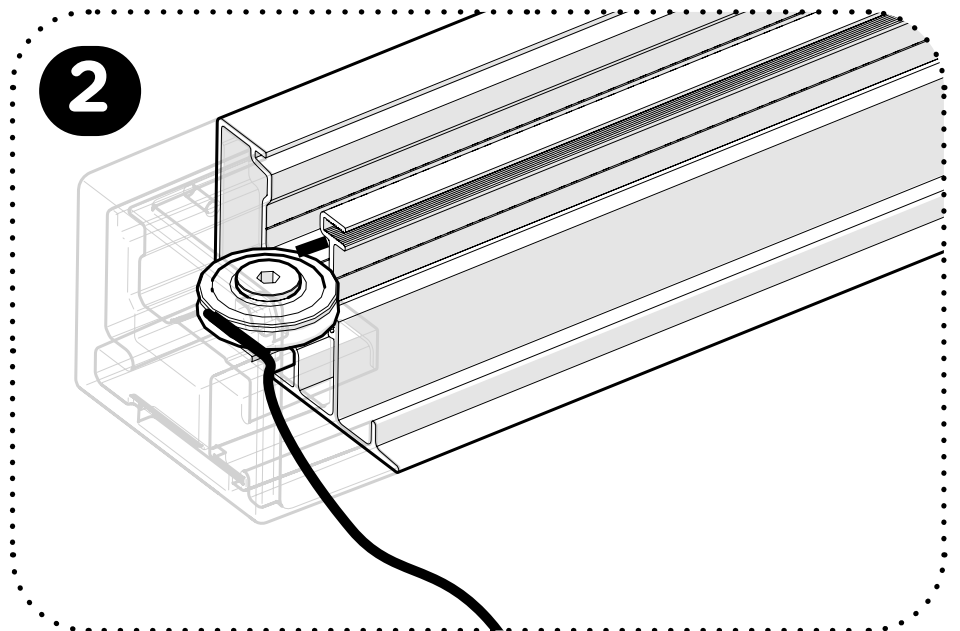
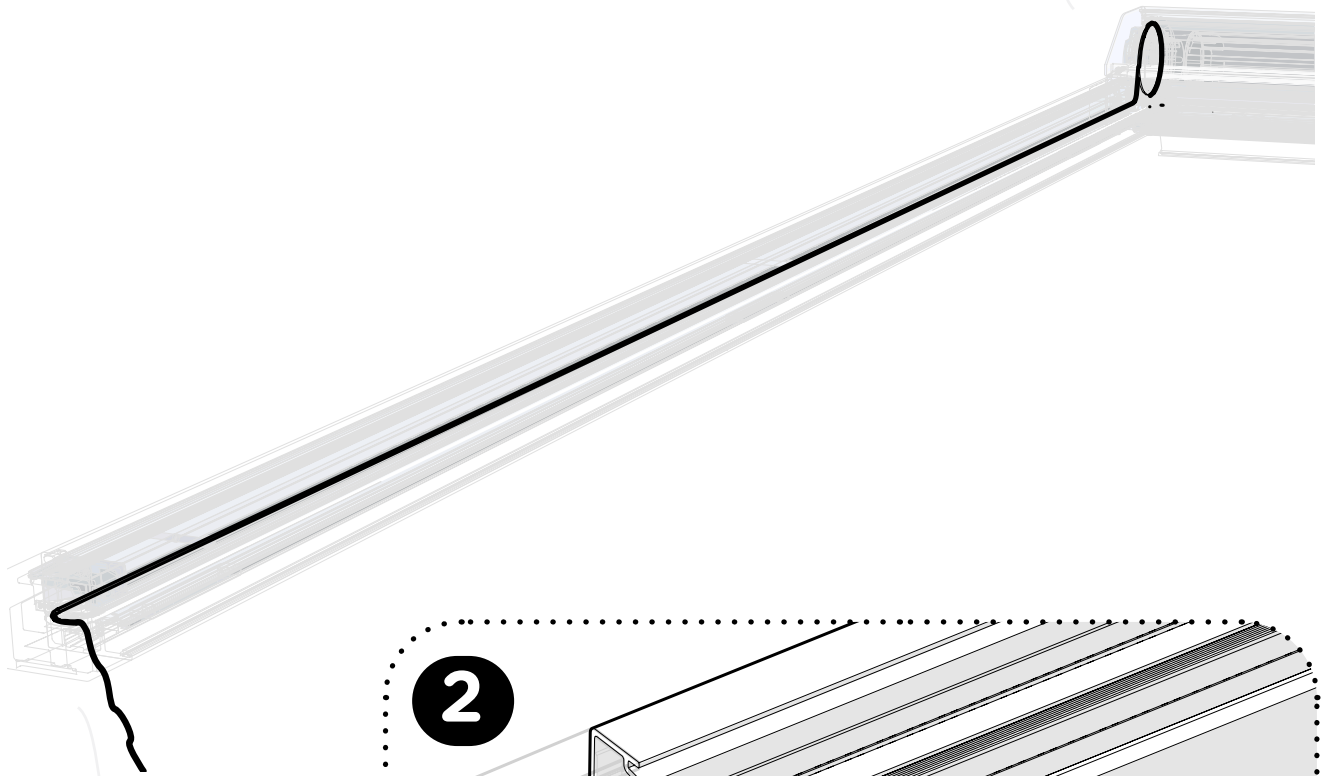
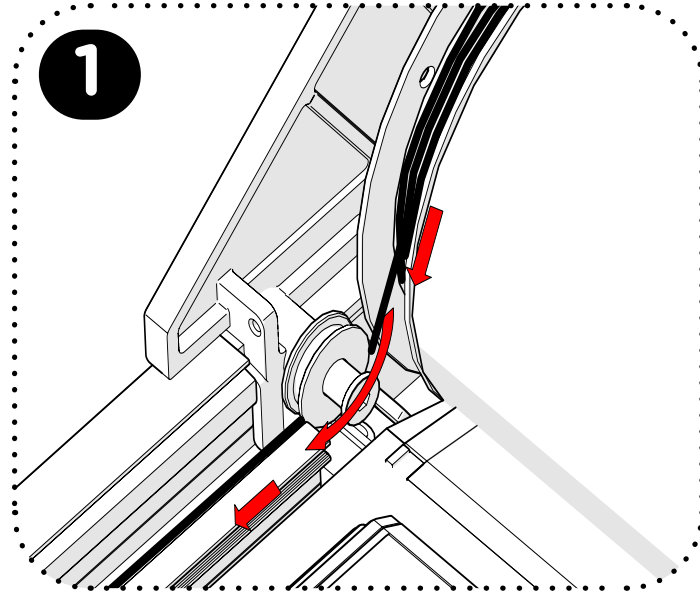
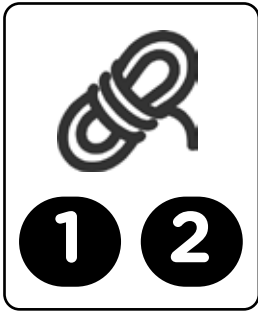

10

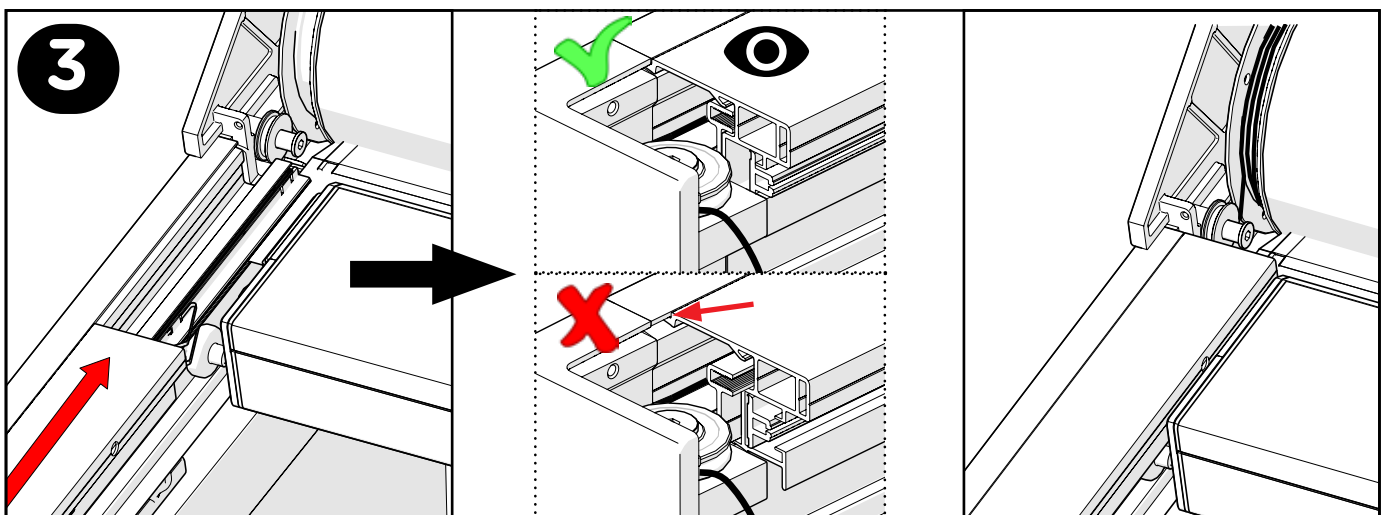
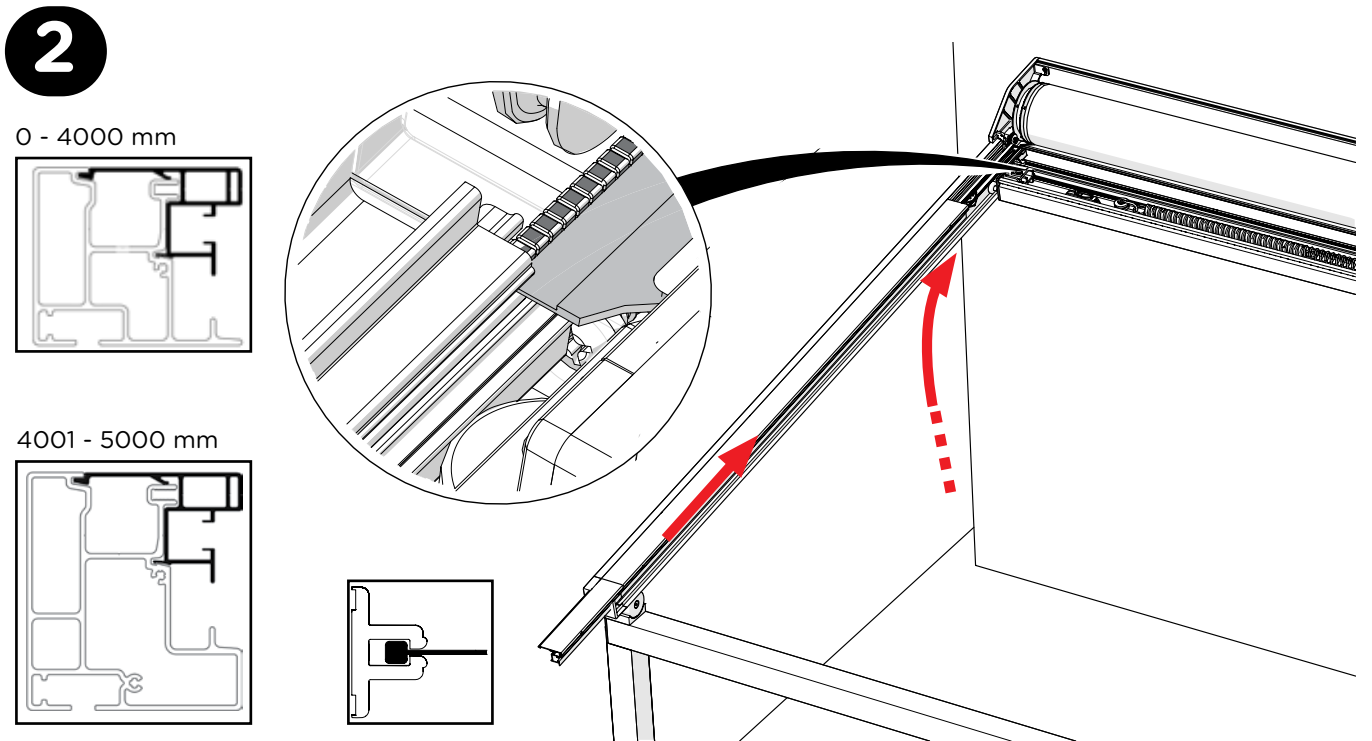
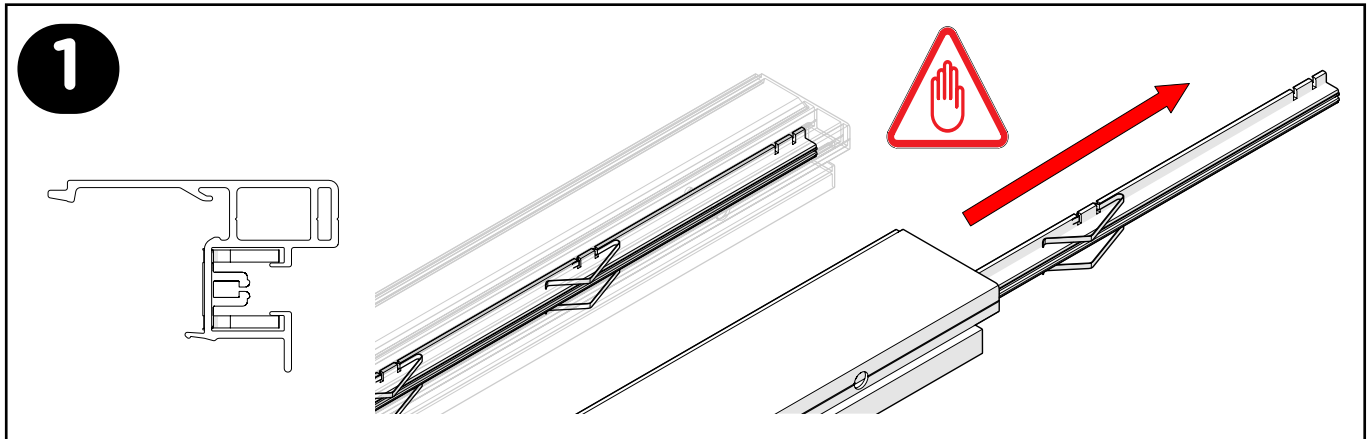

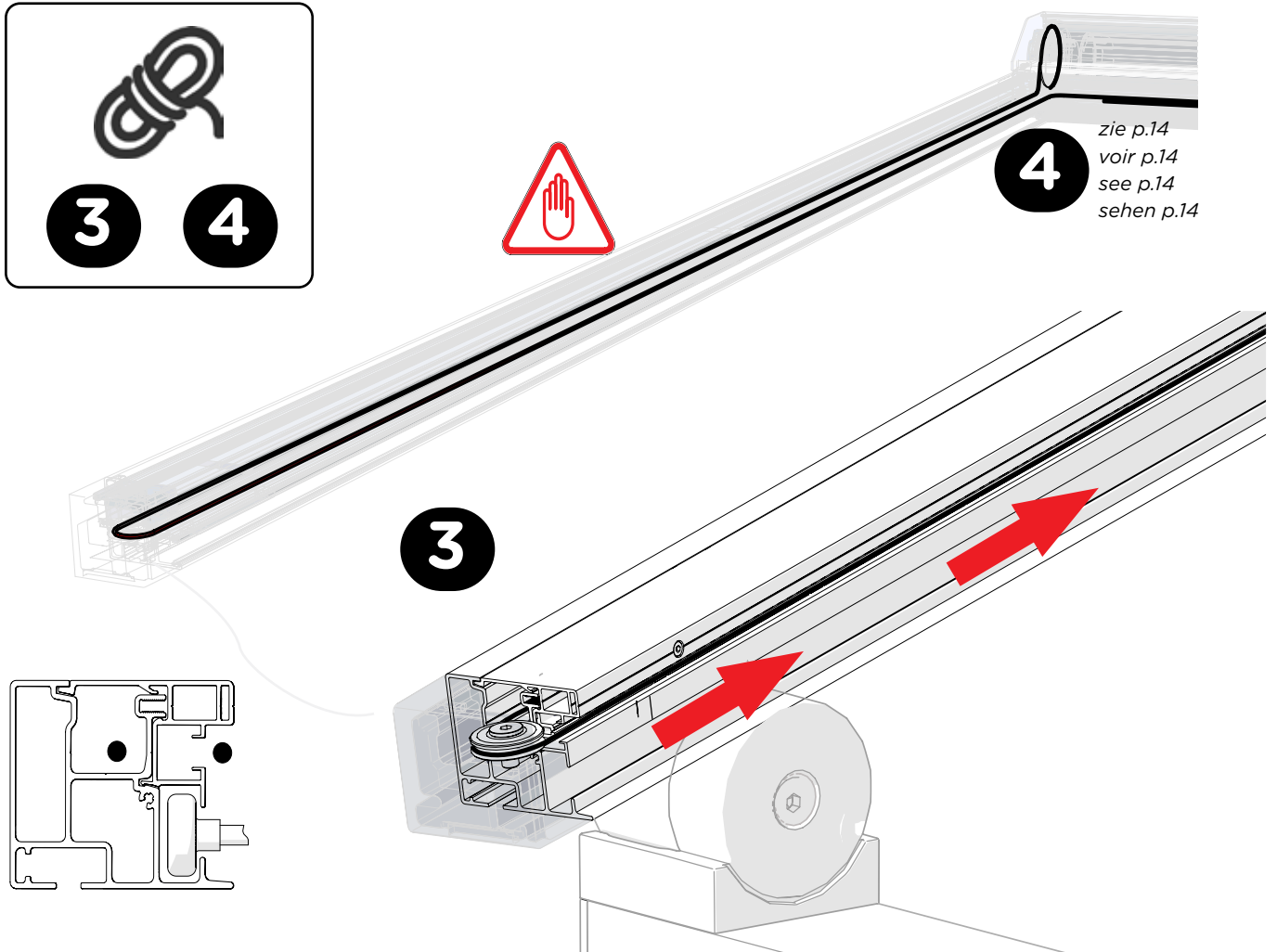
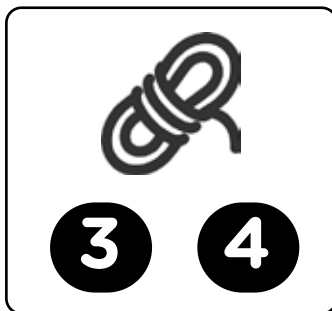
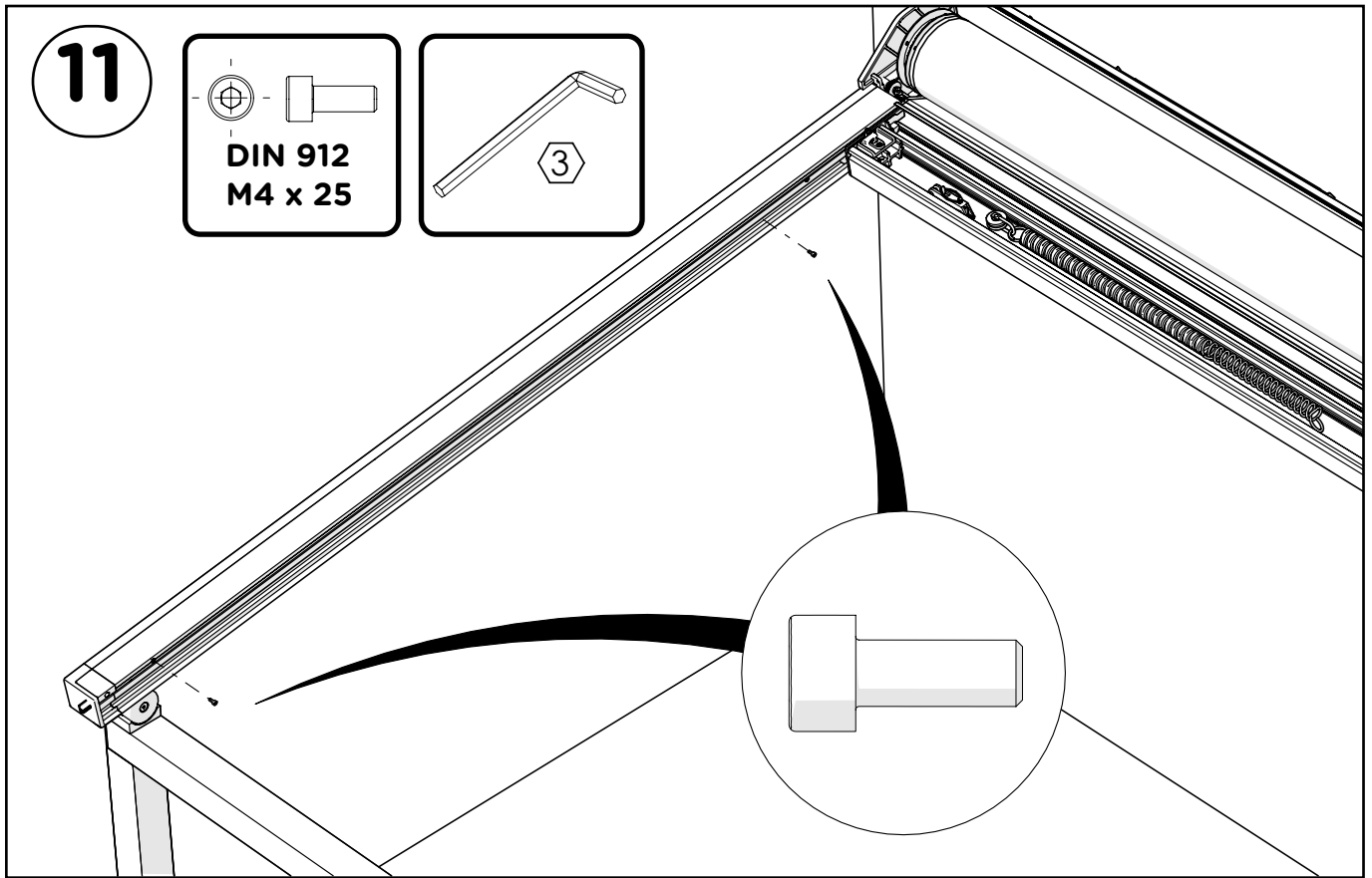

4

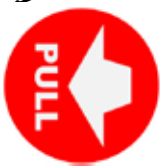
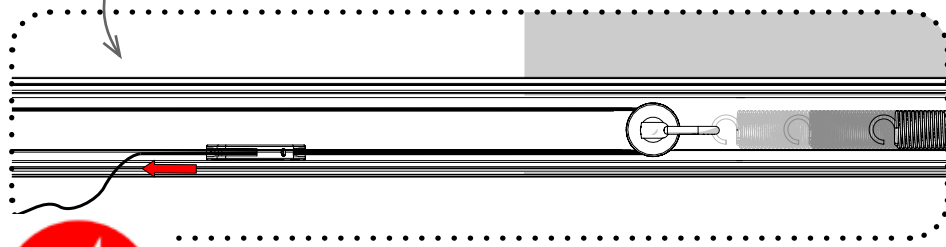
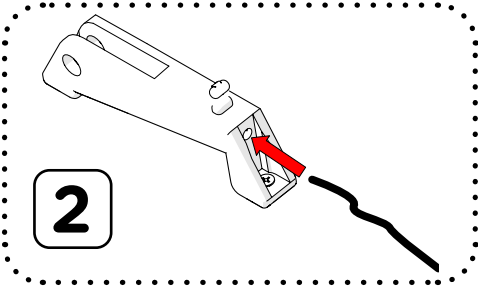
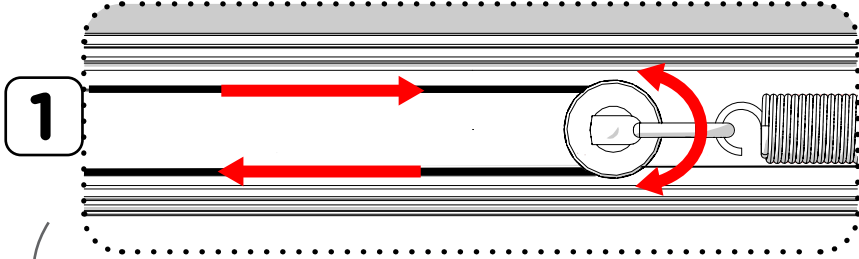
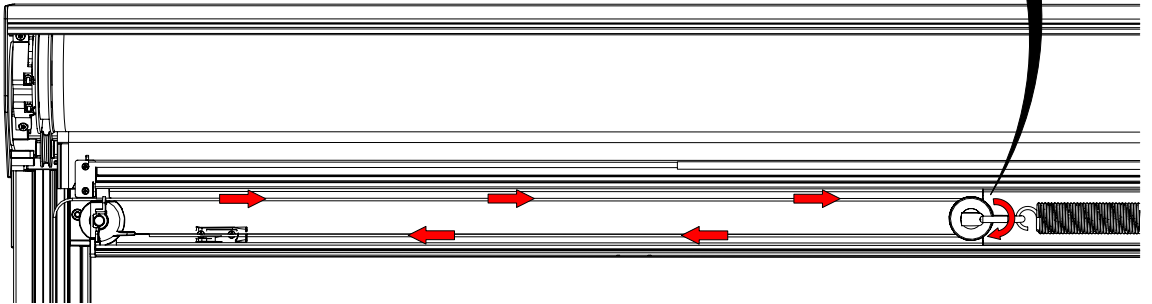
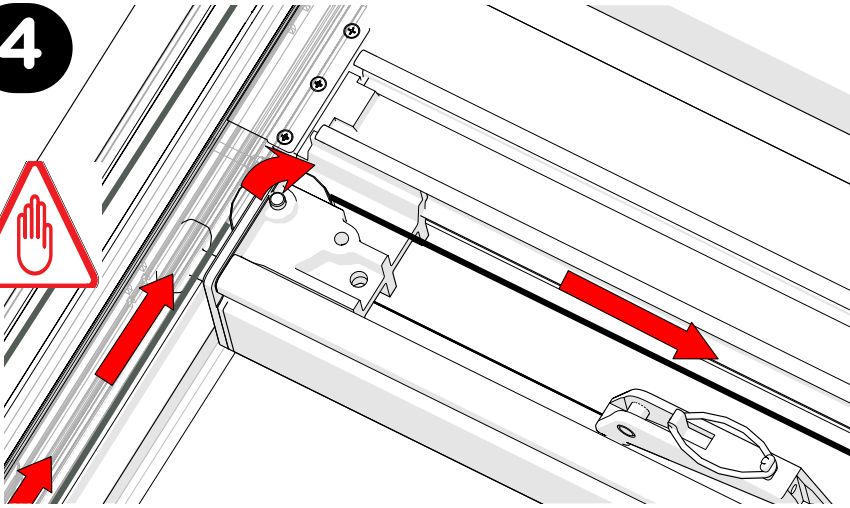

3

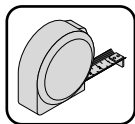

zie p.15  
voir p.15  
see p.15  
sehen p.15

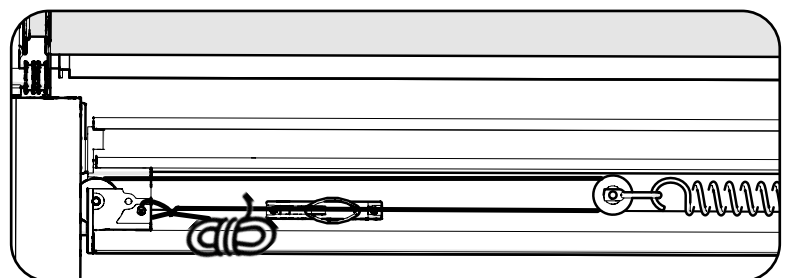
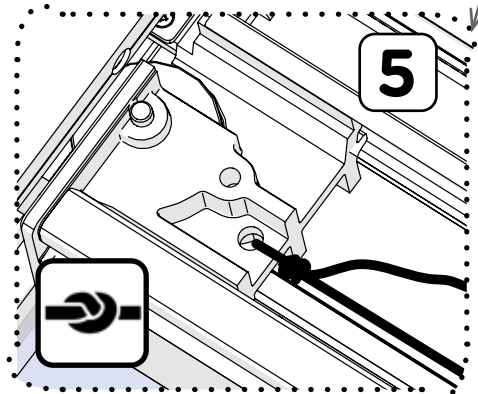
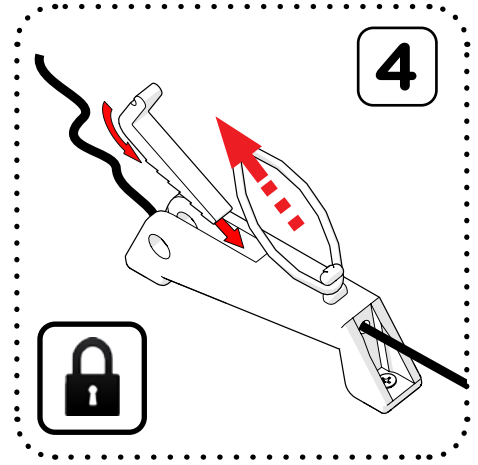

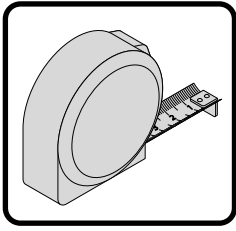

Tabel VEERAFSTAND R (in mm)  
 Table de la distance R du ressort (en mm)  
 Table spring distance R (in mm)  
 Tabelle der Federspannlänge R (in mm)

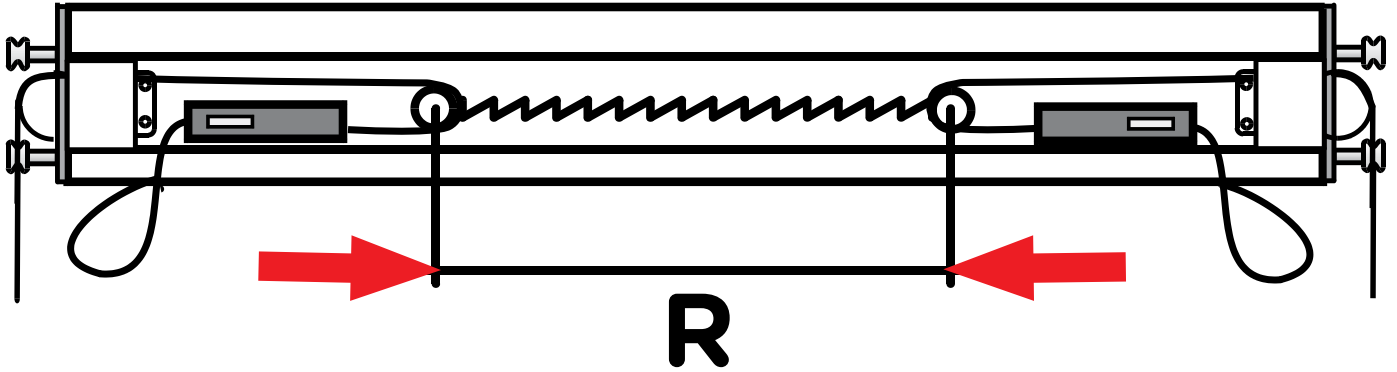

AFSTAND **R\***  
 DISTANCE **R\***  
 ENTFERNUNG **R\***

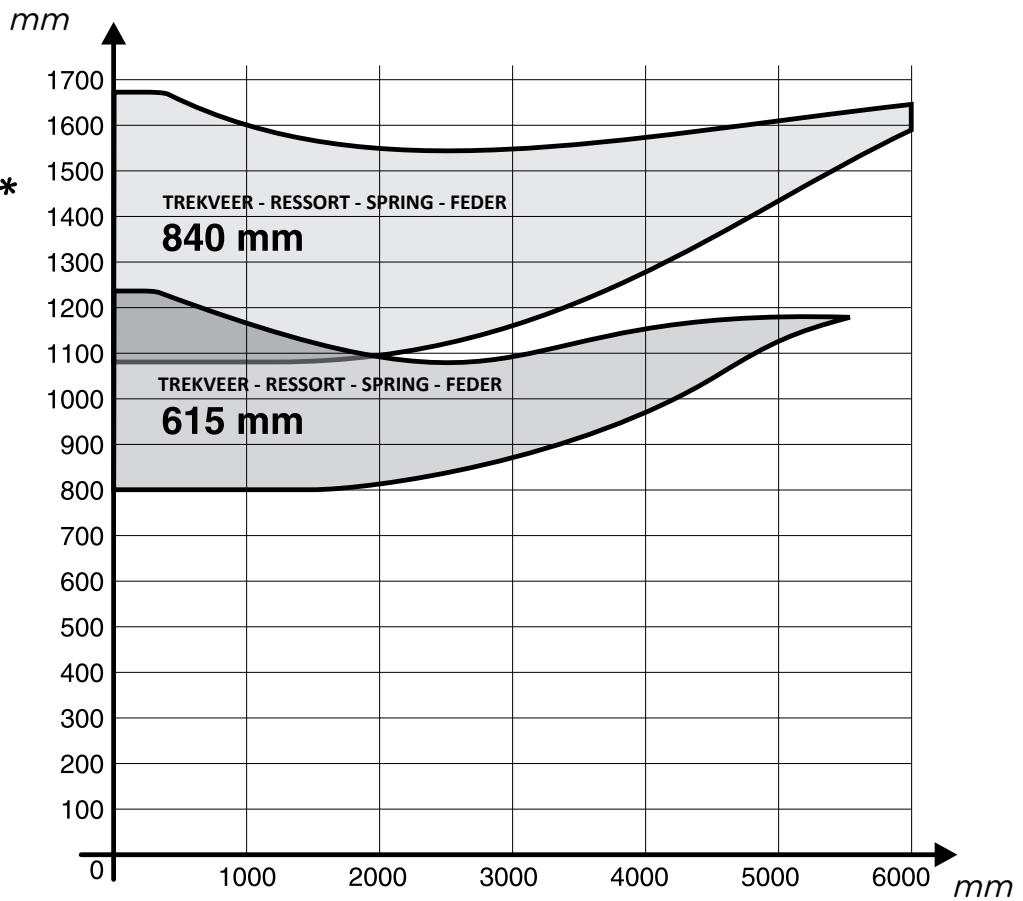

UITVAL  
 PROFONDEUR  
 SLOPE  
 AUSFALL

\* AFHANGKELIJK VAN HET TYPE VEER (650mm / 850mm), AFSTAND **R** AFLEZEN IN GEKLEURDE ZONE.  
 LIRE LA DIMENSION **R** DANS LA ZONE COLORE SUIVANT LE TYPE DE RESSORT.  
 DEPENDING ON THE TYPE OF SPRING (650MM / 850MM), READ DISTANCE **R** IN COLORED ZONE.  
 ABHÄNGIG VOM FEDERTYP (650 MM / 850 MM), ABSTAND **R** IM FARBIGEN BEREICH ABLESEN



12

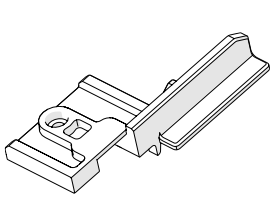
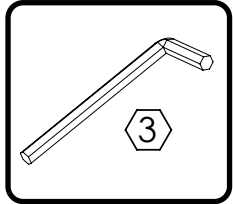
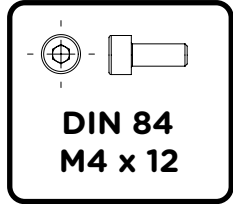
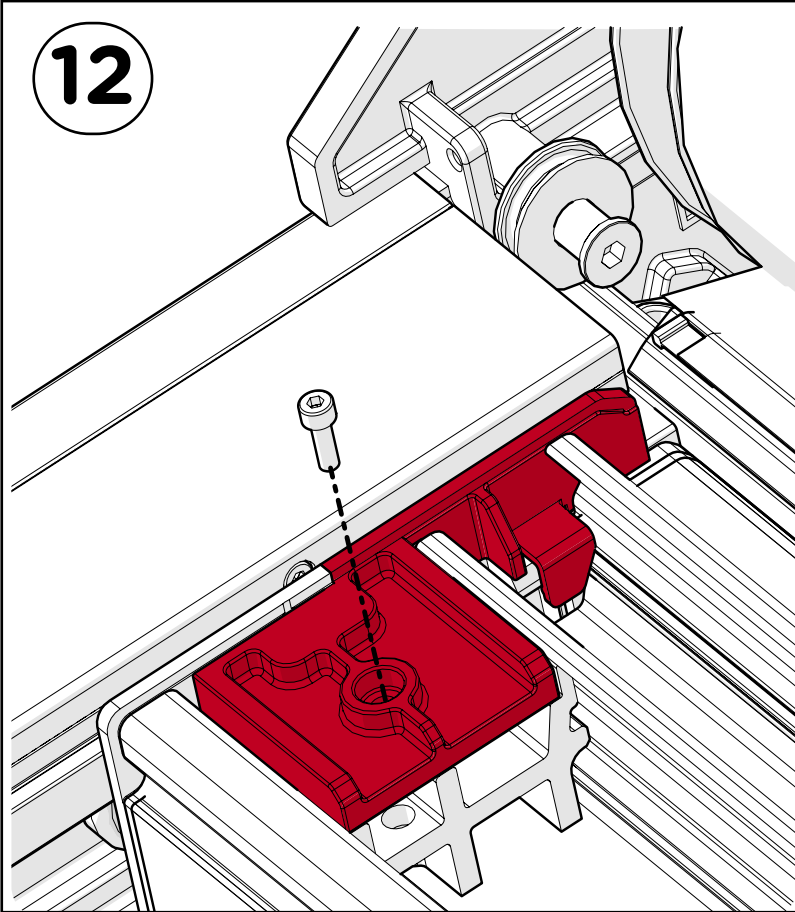

Right  
Rechts  
Droite

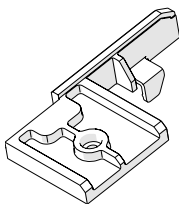

Left  
Links  
Gauche

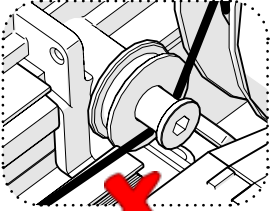

X

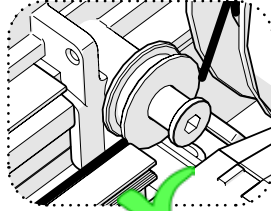

✓

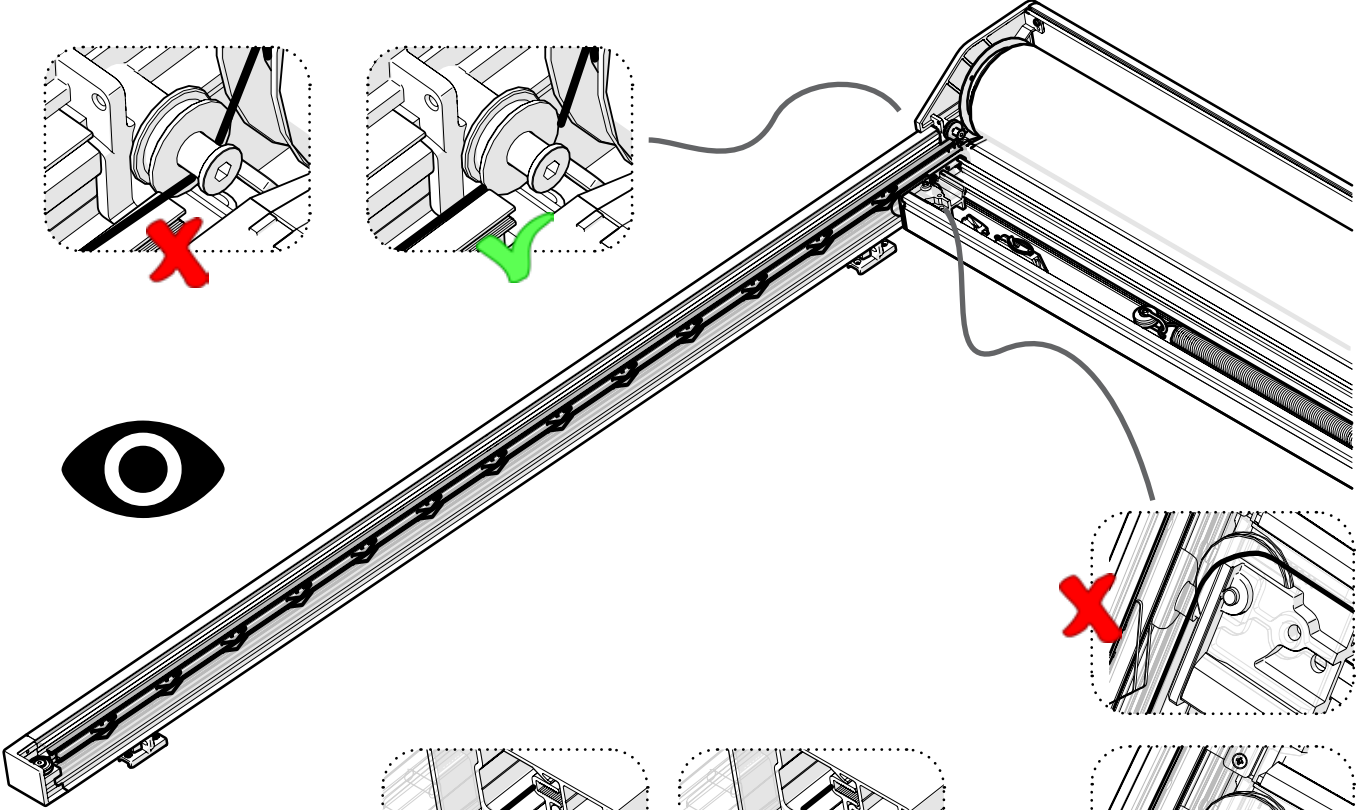

X

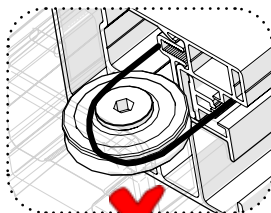

X

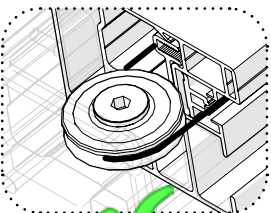

✓

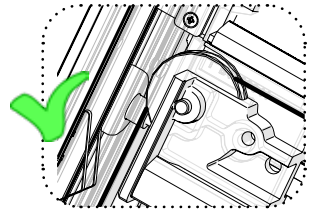

✓

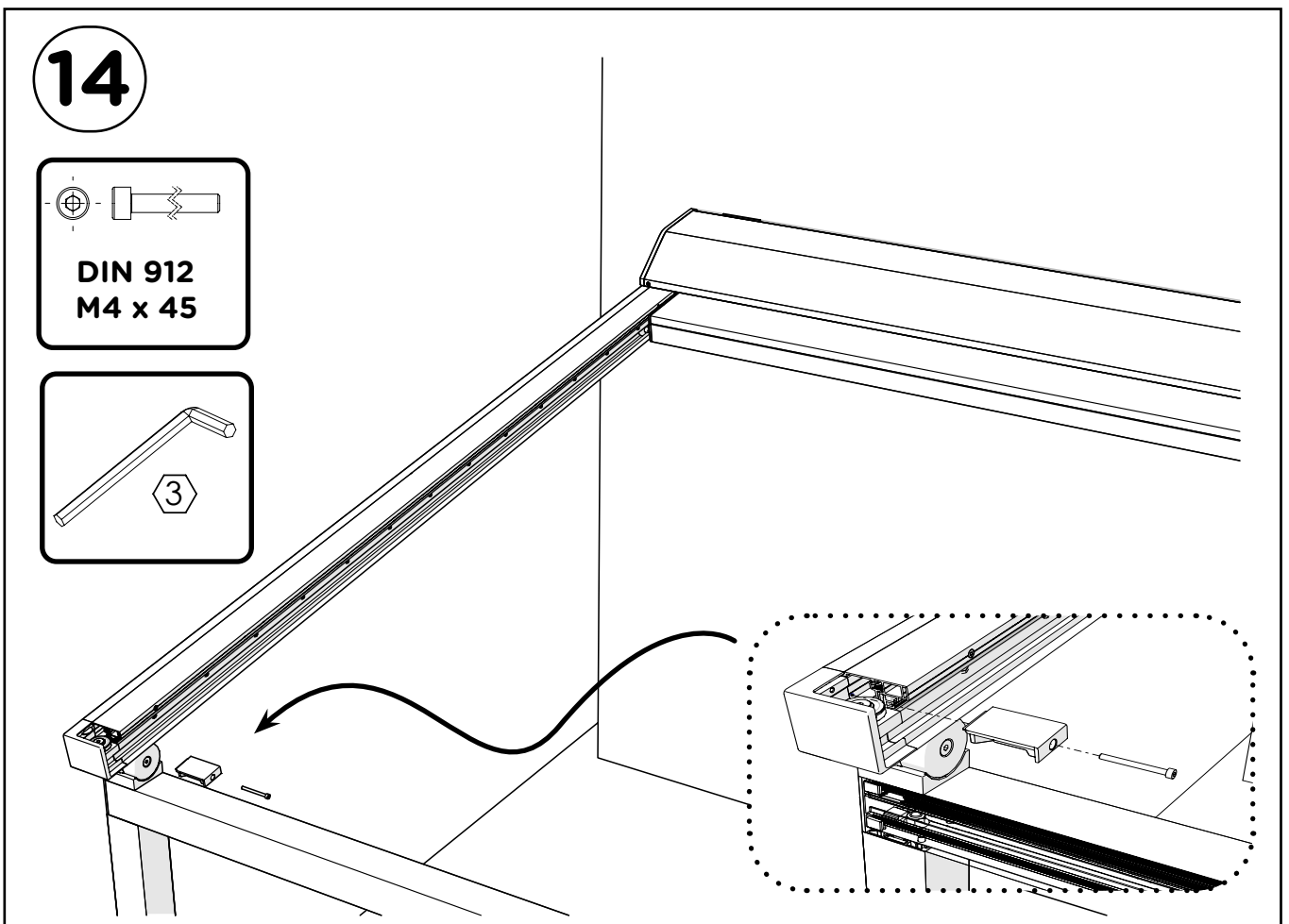
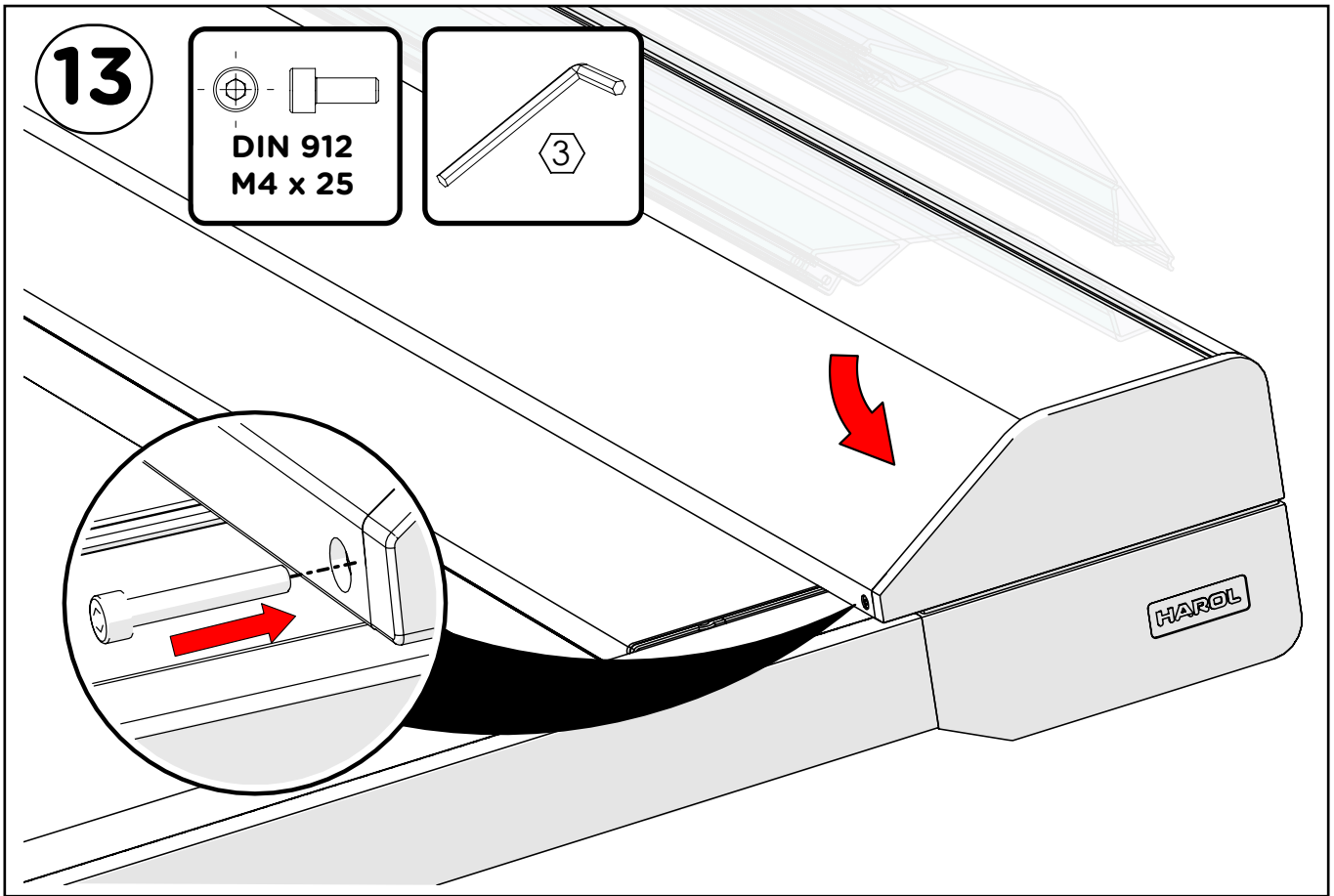

15

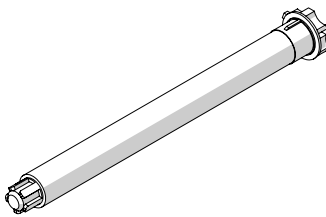
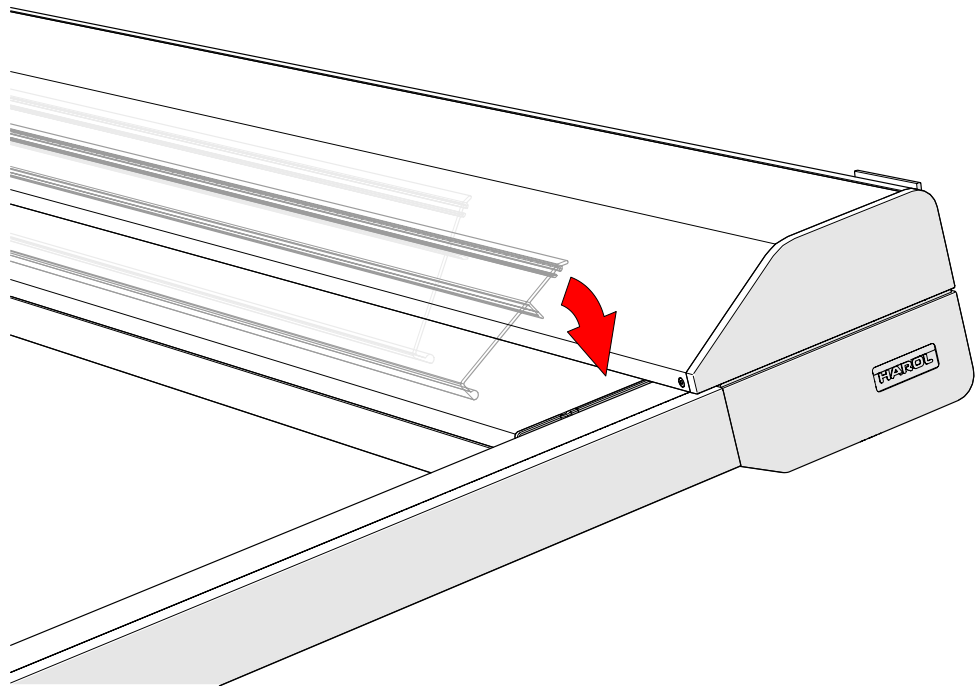
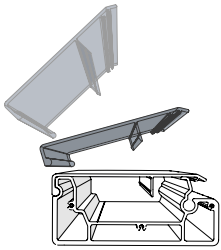

somfy.

www.somfy.com



see instruction manual Somfy (included)  
zie gebruikershandleiding Somfy (bijgevoegd)  
voir manuel d'instruction Somfy (inclus)  
siehe Bedienungsanleitung Somfy (inbegriffen)

OREA 50 WT 25/17  
OREA 50 WT 40/17  
Gemini 25/17 SLT50  
Mariner 40/17 SLT50  
Orea 25/17 LT50 RTS  
Orea 40/17 LT50 RTS  
Sunea 50 IO 25/17  
Sunea 50 IO 40/17

16

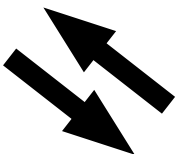

x1

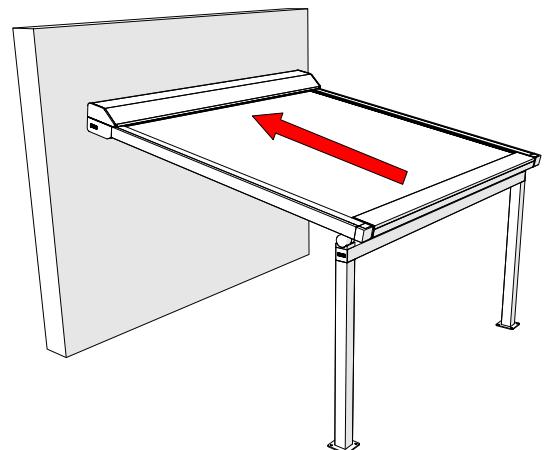
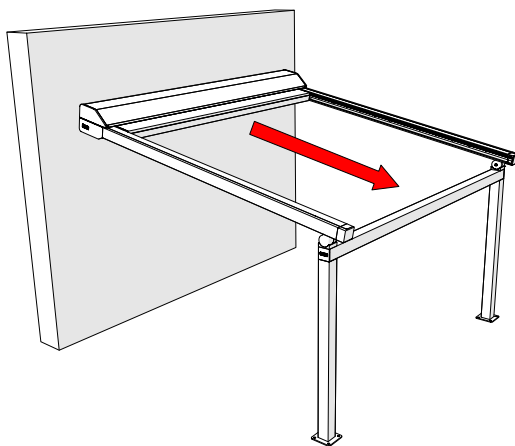



# 17 CONTROL(E)

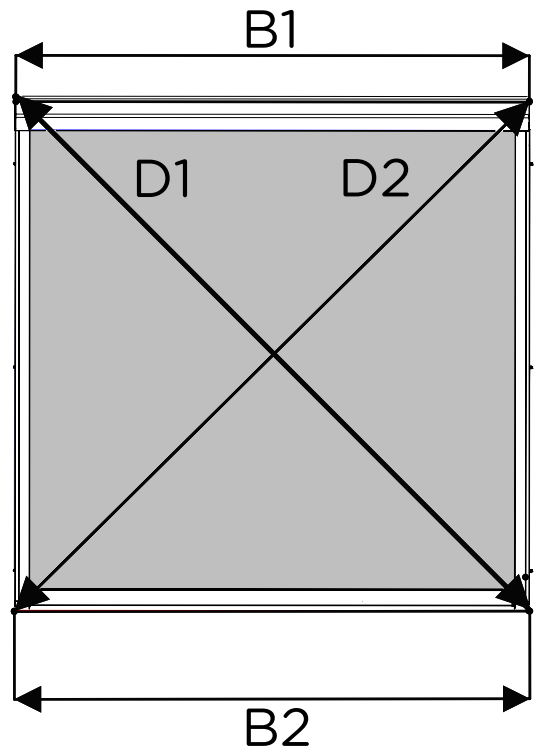
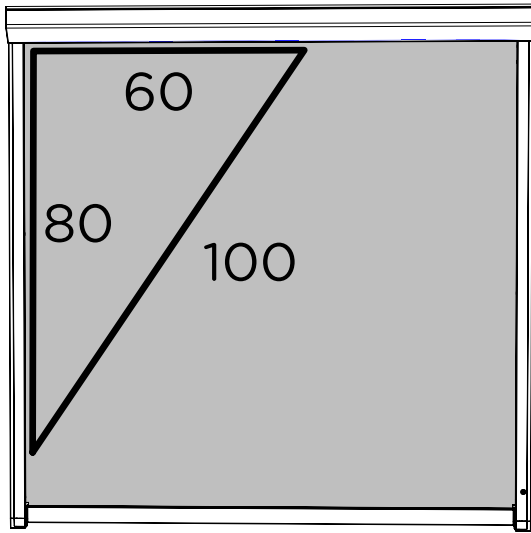
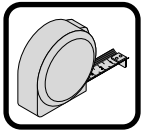

**B1 = B2 & D1 = D2**  
 (+/- 2mm)      (+/- 2mm)

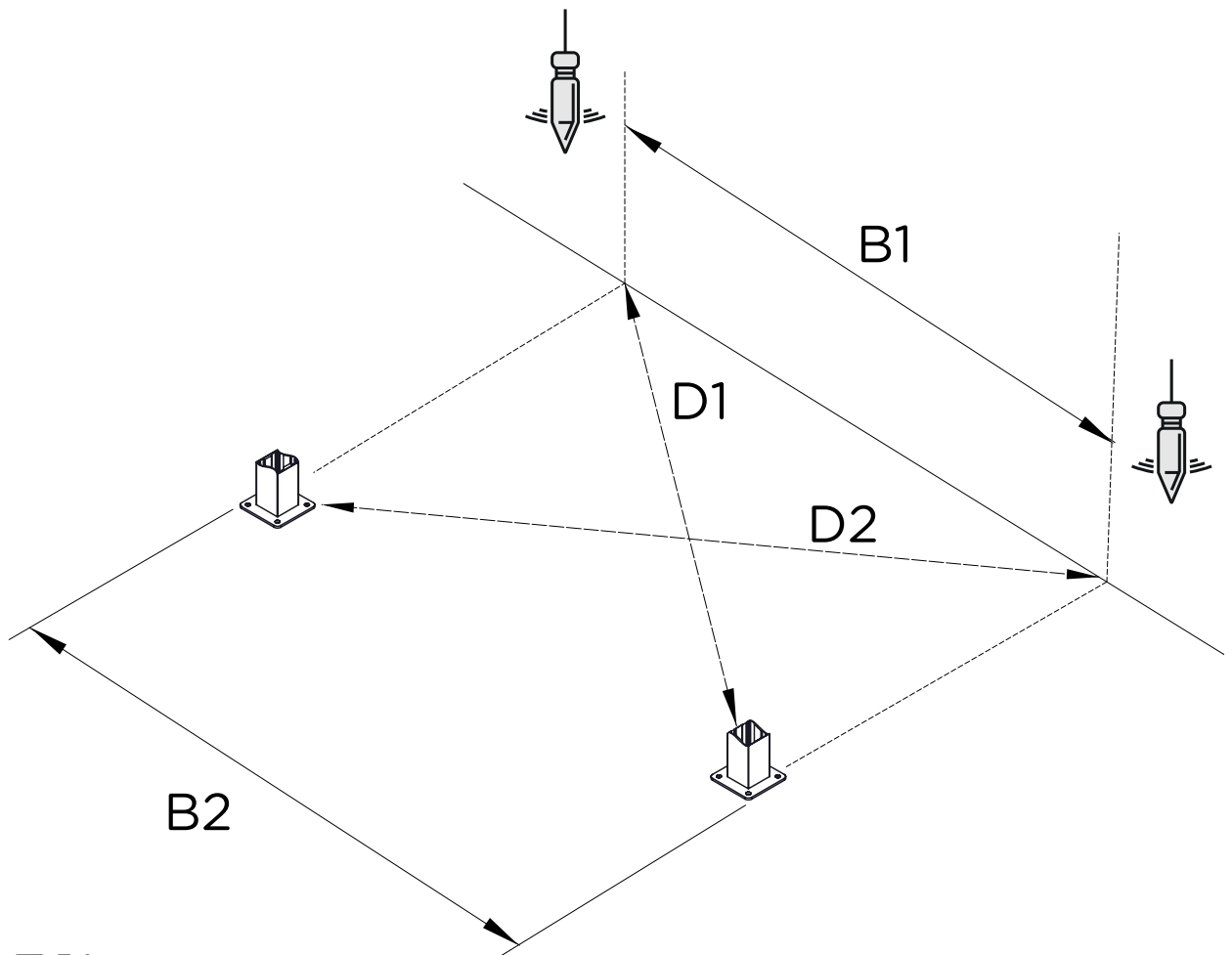

18

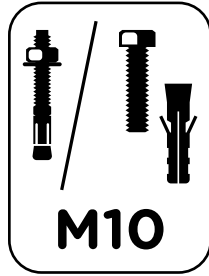
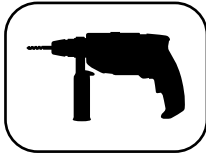

VOORBEELD  
EXAMPLE  
BEISPIEL

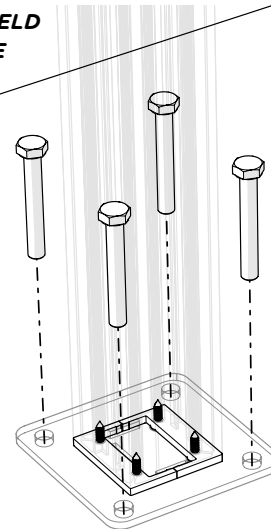

**NL** GEBRUIK DE GESCHIKTE BEVESTIGINGSMATERIALEN PASSEND BIJ DE BOUWZIJDIGE OMSTANDIGHEDEN !

**FR** UTILISEZ DES MATERIAUX DE FIXATIONS ADAPTES SUIVANT LES CONDITIONS DE CONSTRUCTION !

**EN** USE SUITABLE FITTING MATERIALS CORRESPONDING TO ONSITE CONDITIONS !

**DU** GEEIGNETE BEFESTIGUNGSMATERIALEN ENTSPRECHEND DER BAUSEITIGEN GEGEBENHEITEN VERWENDEN !

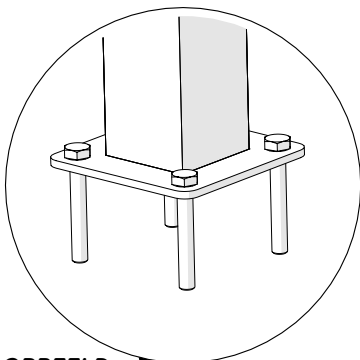
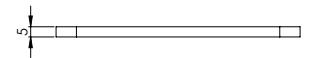
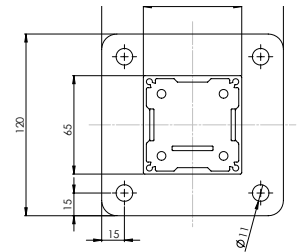
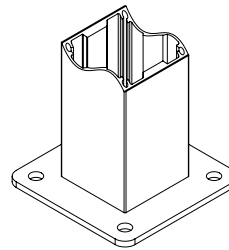

VOORBEELD  
EXAMPLE  
BEISPIEL

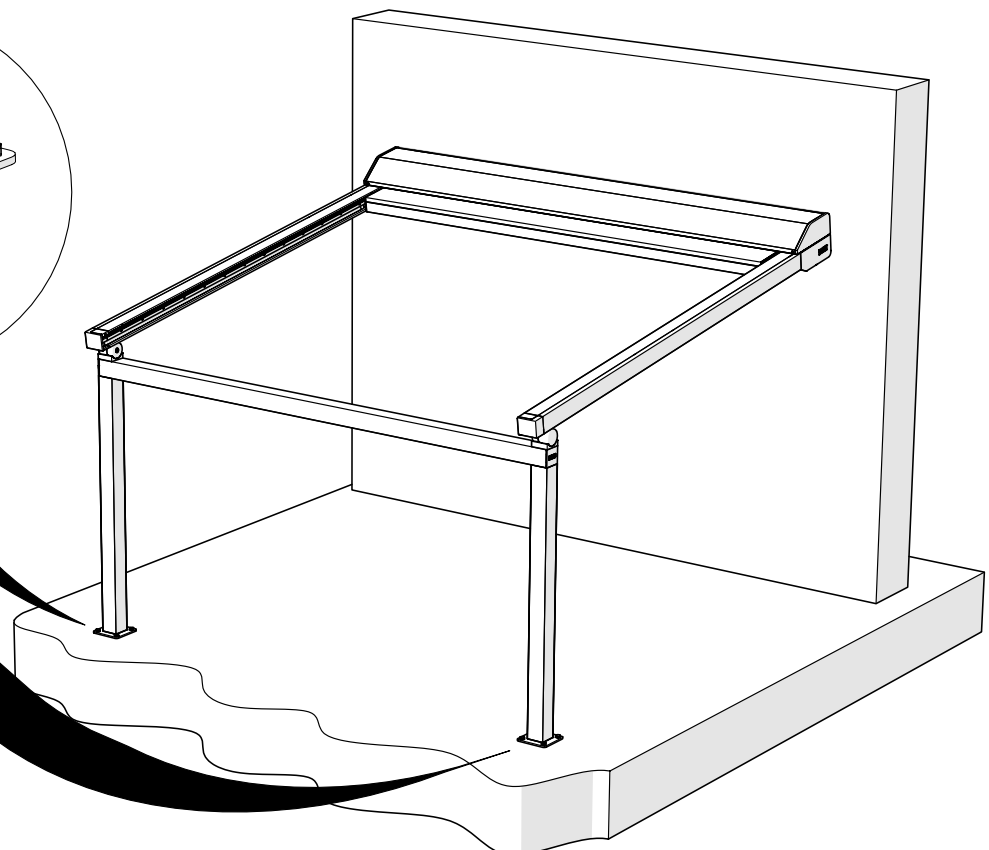



GEKOPPELD - COUPLE - LINKED - GEKOPPELT

1

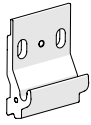

zie p.6  
voir p.6  
see p.6  
sehen p.6

2

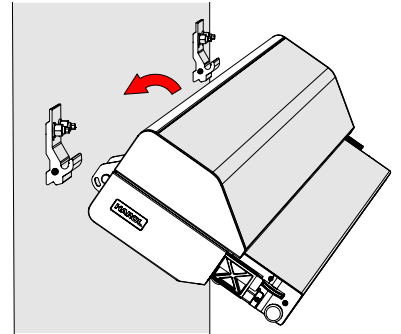
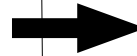
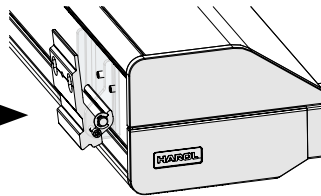
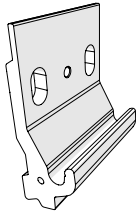

3

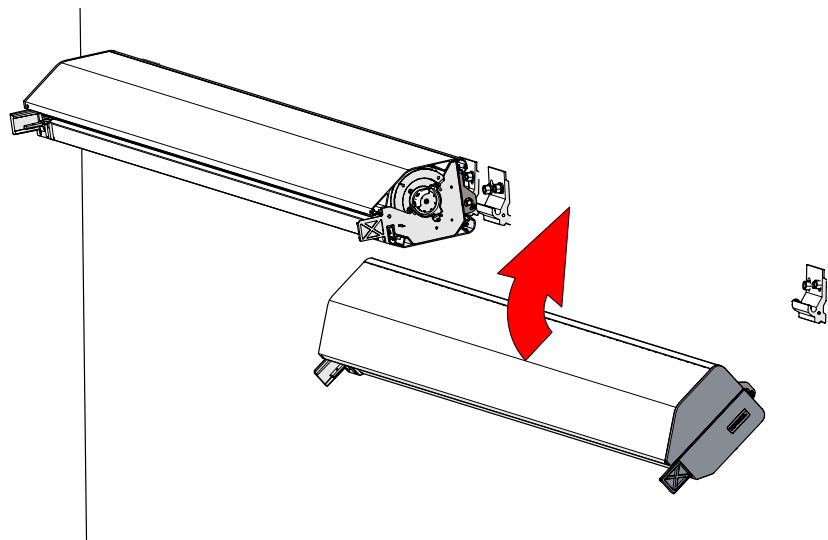
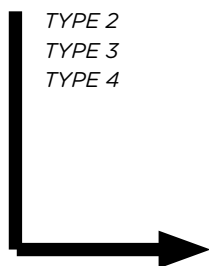
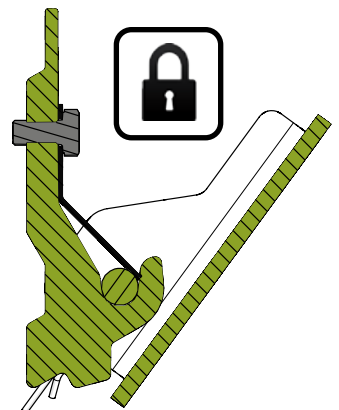
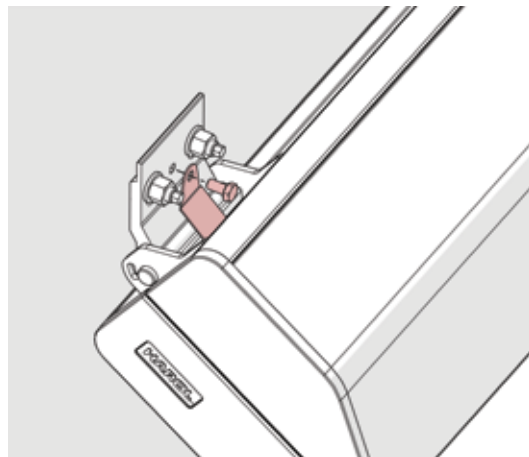
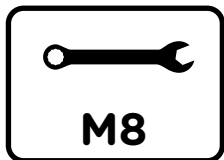
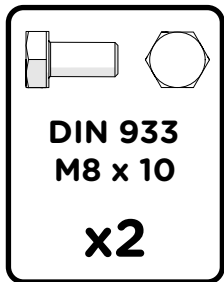

4

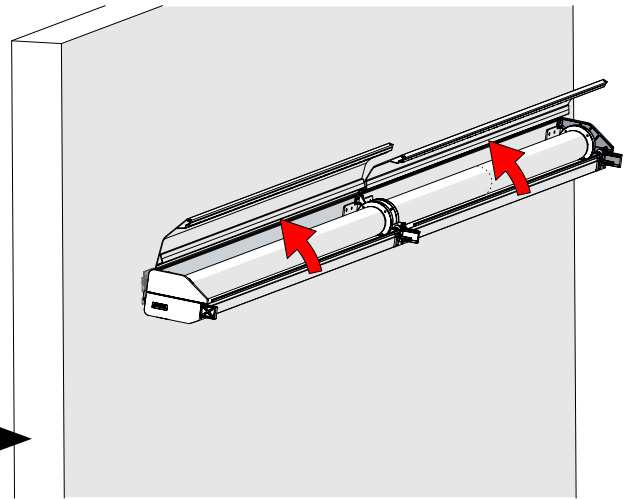
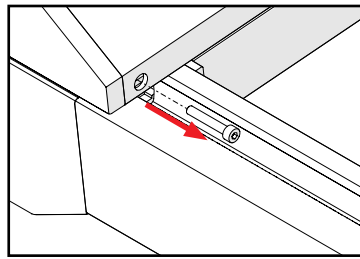
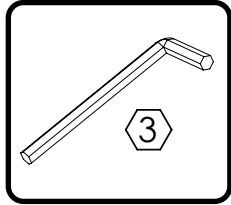
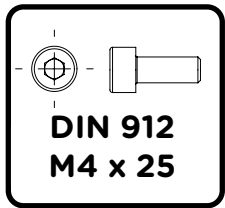

5

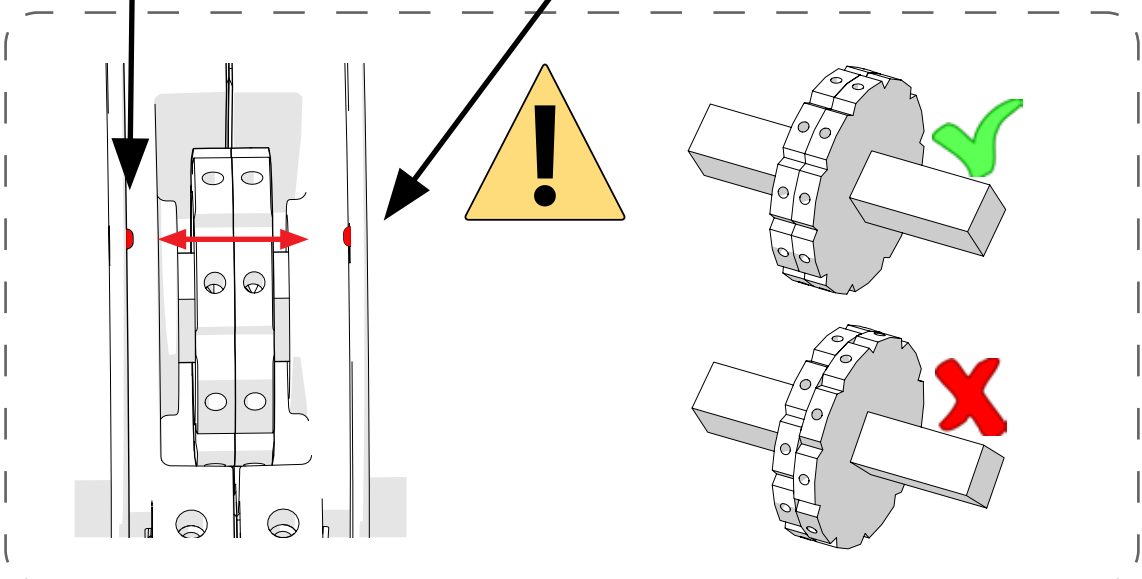
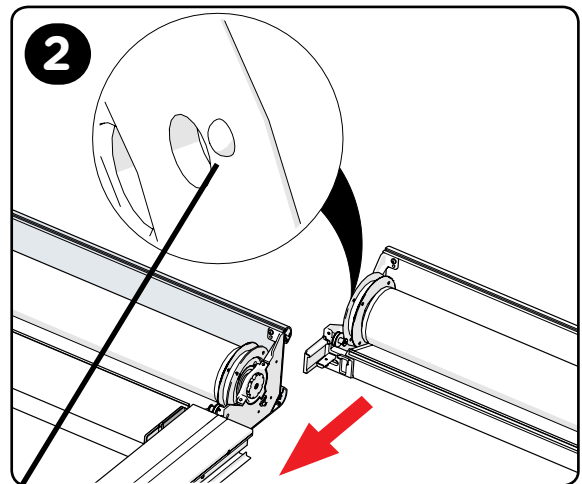
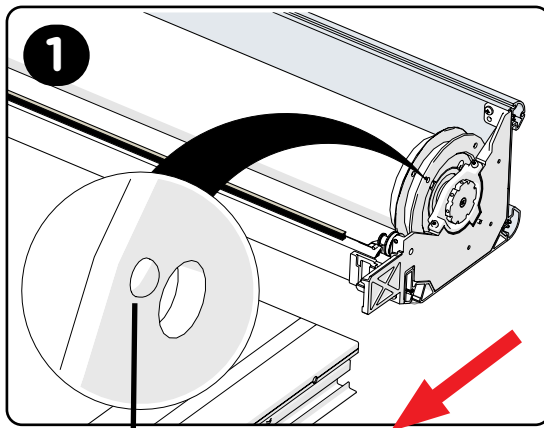

6

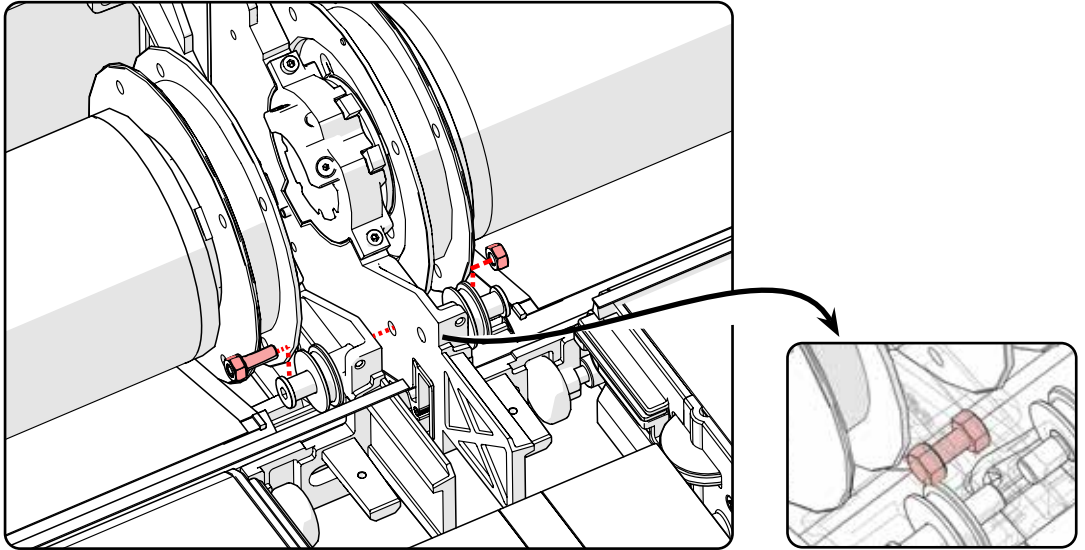
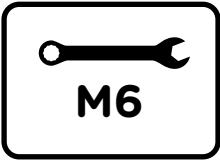
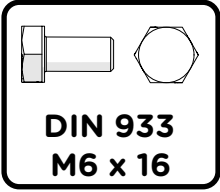

7

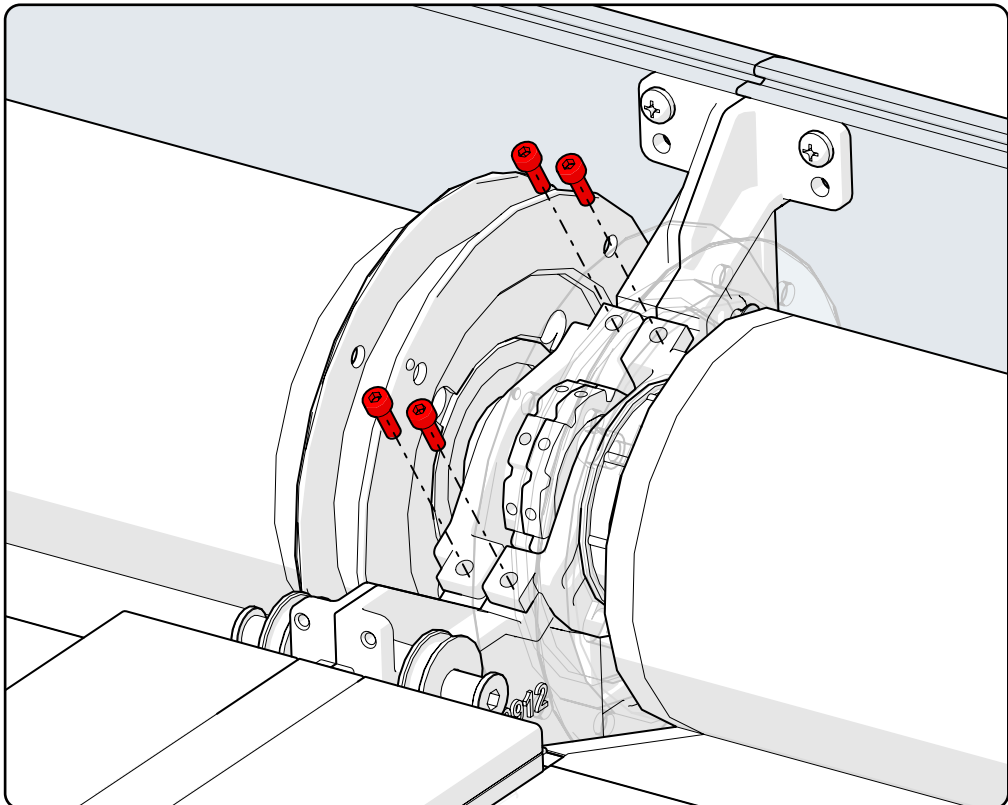
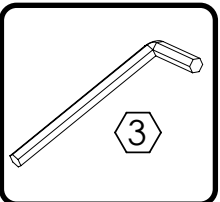
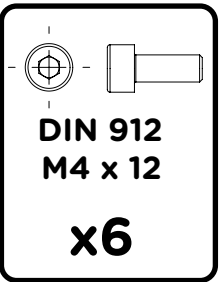

# MONTAGE - MOUNTING VERSUZ

8

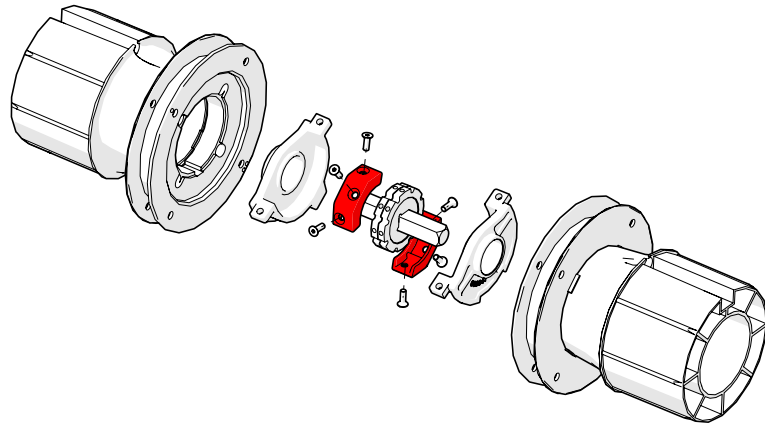
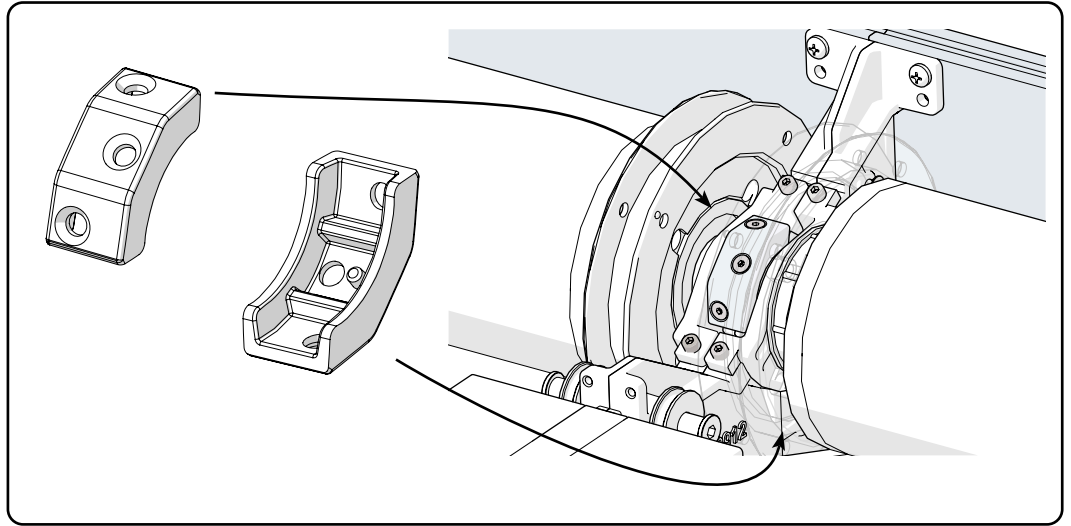
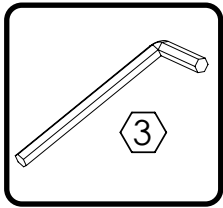
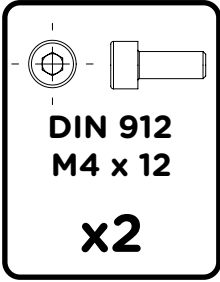

9

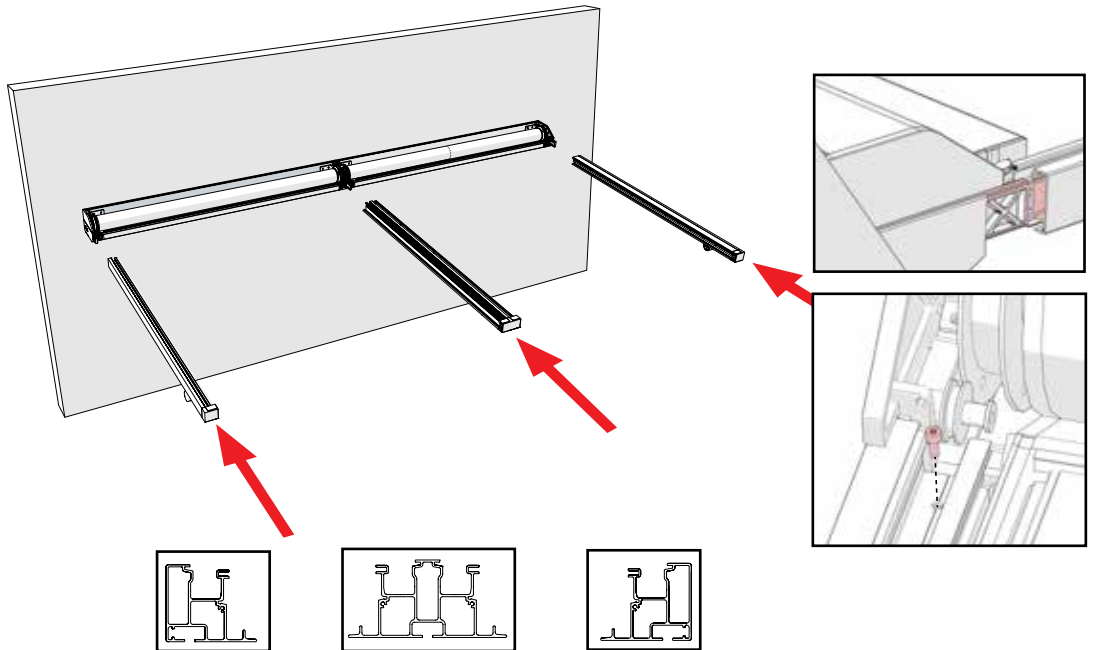
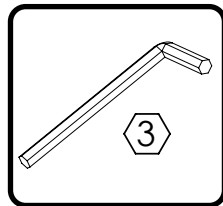
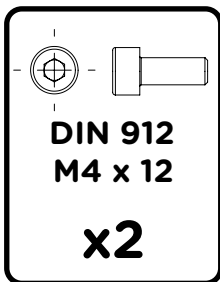

10

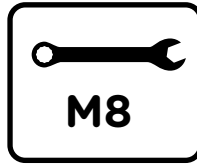
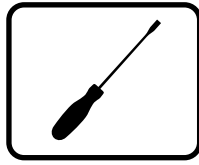
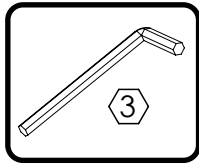

TYPE 2

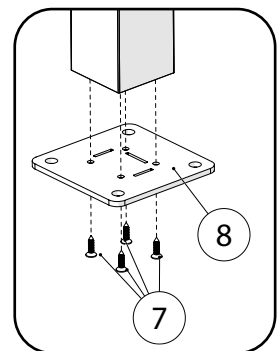
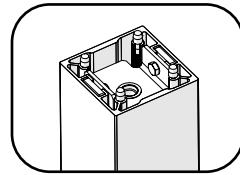
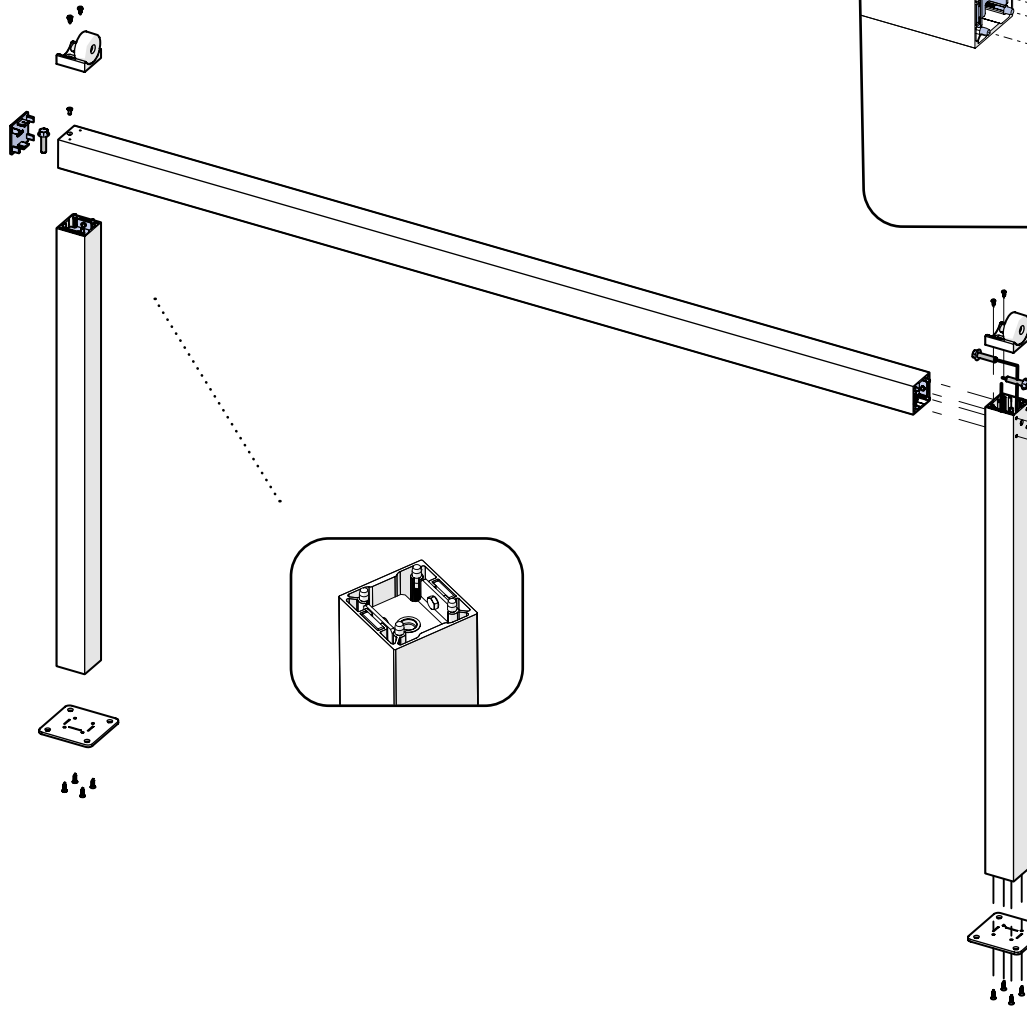
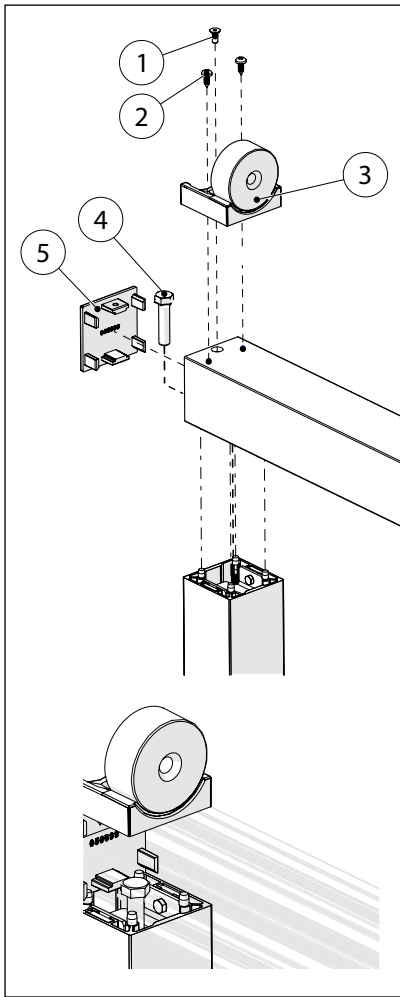



# MONTAGE - MOUNTING VERSUZ

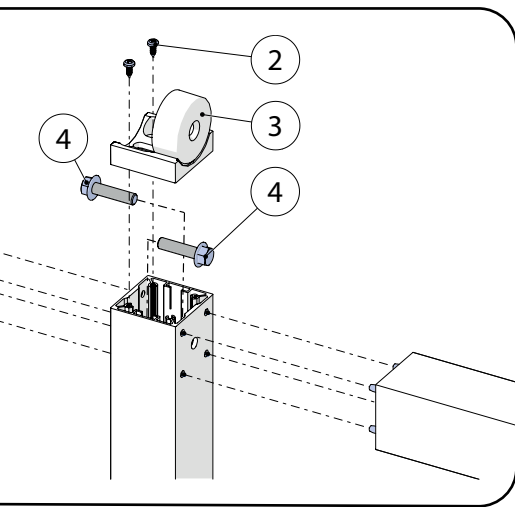

1	Din 7991 M4 x 12 (063293)		2
2	Din 7981 4,8 x 19 (014849)		6
3	050905		3
4	DIN 933 - M10 x 35 (002246)		4
5	050699		2
6	DIN 7982 4,8 x 19 (003092)		8
7	050940		2

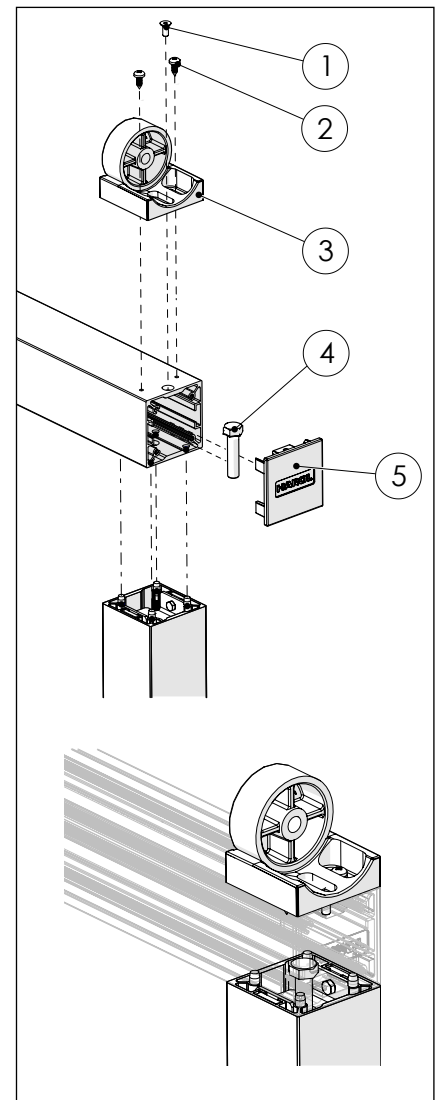
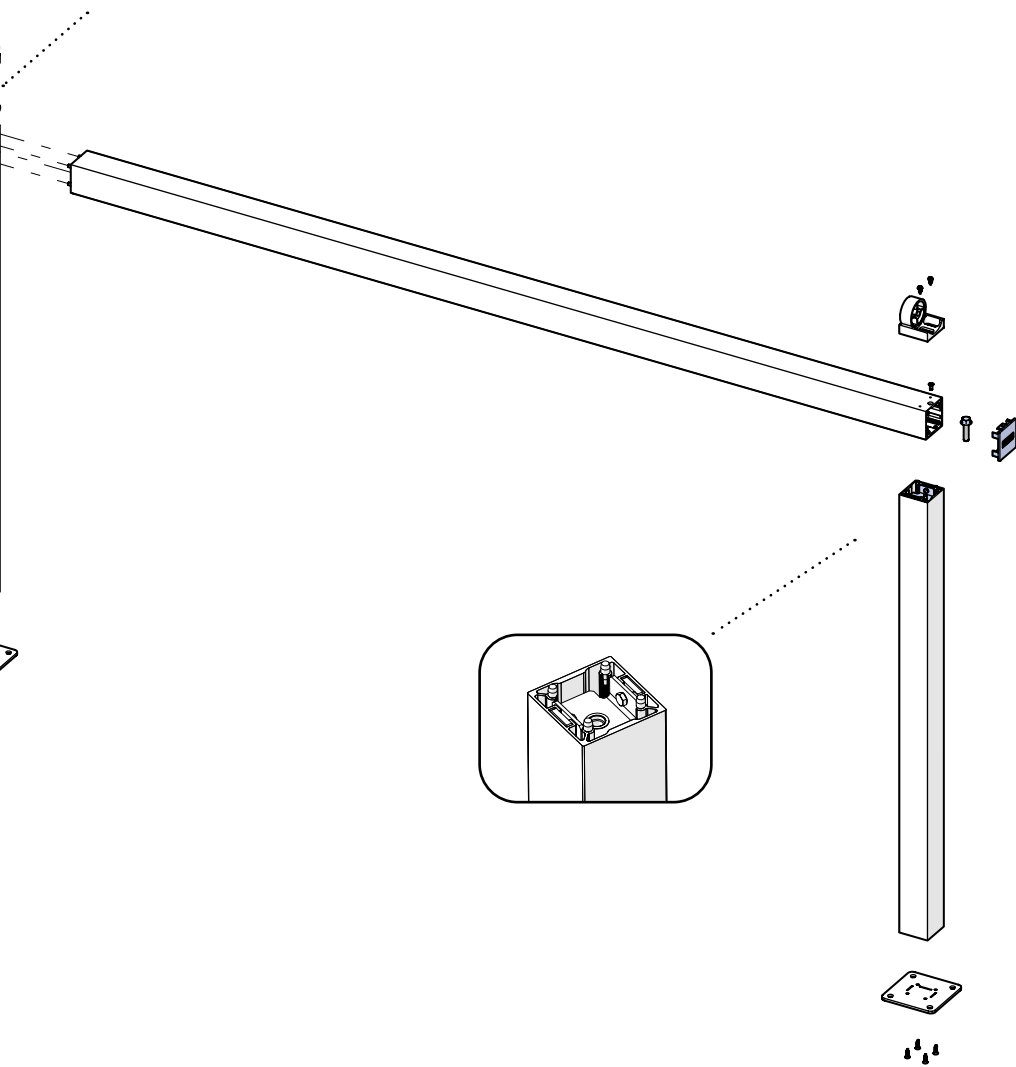

6

7

zie p.9 - p.20  
voir p.9 - p.20  
see p.9 - p.20  
sehen p.9 - p.20

.....

➔

18

TYPE 3 - 4

1



10

zie p.22 - p.27  
voir p.22 - p.27  
see p.22 - p.27  
sehen p.22 - p.27

6

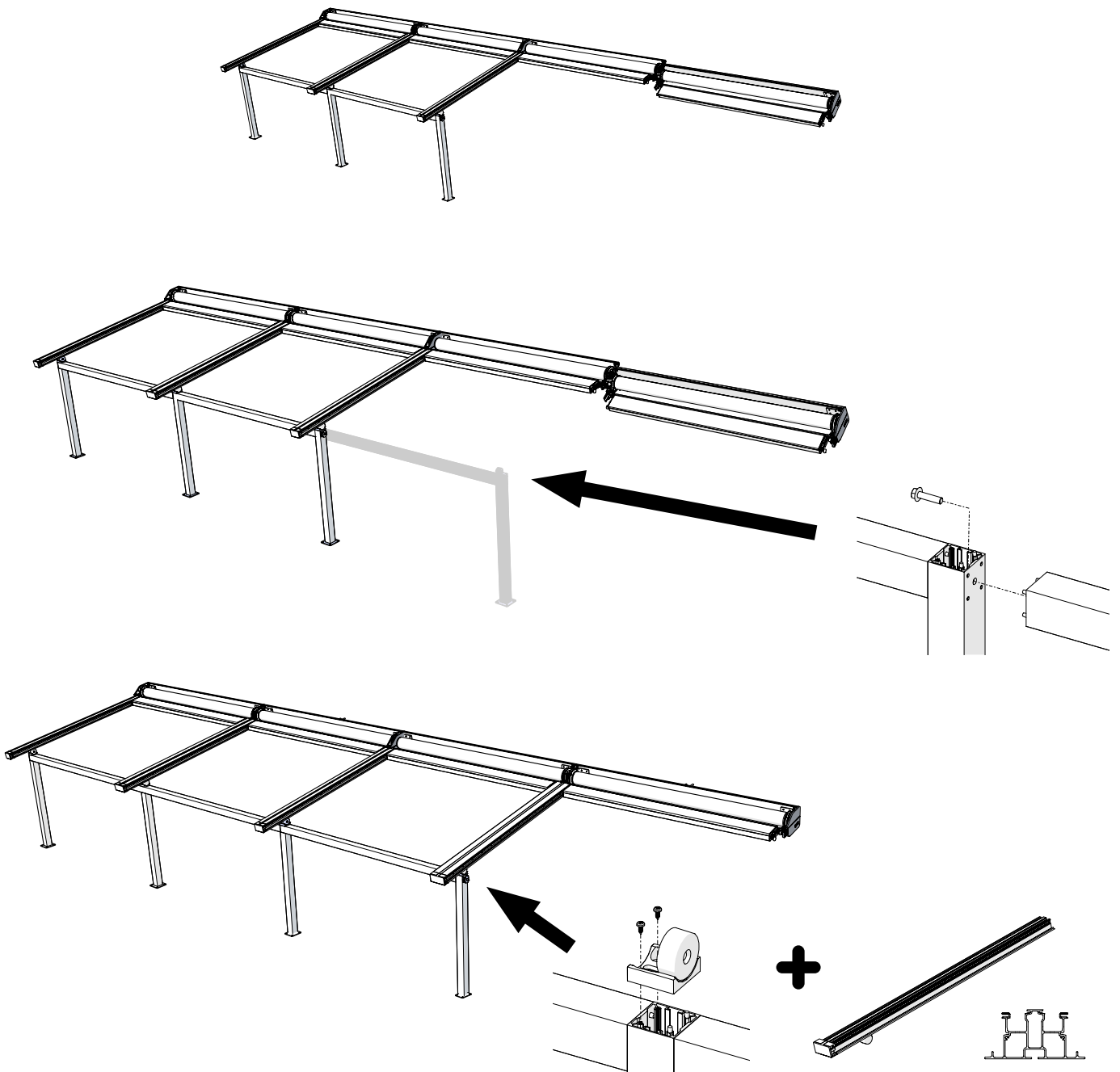
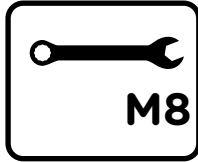
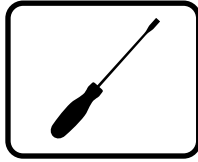
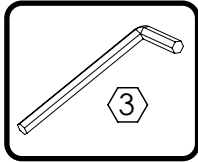

# MONTAGE - MOUNTING VERSUZ

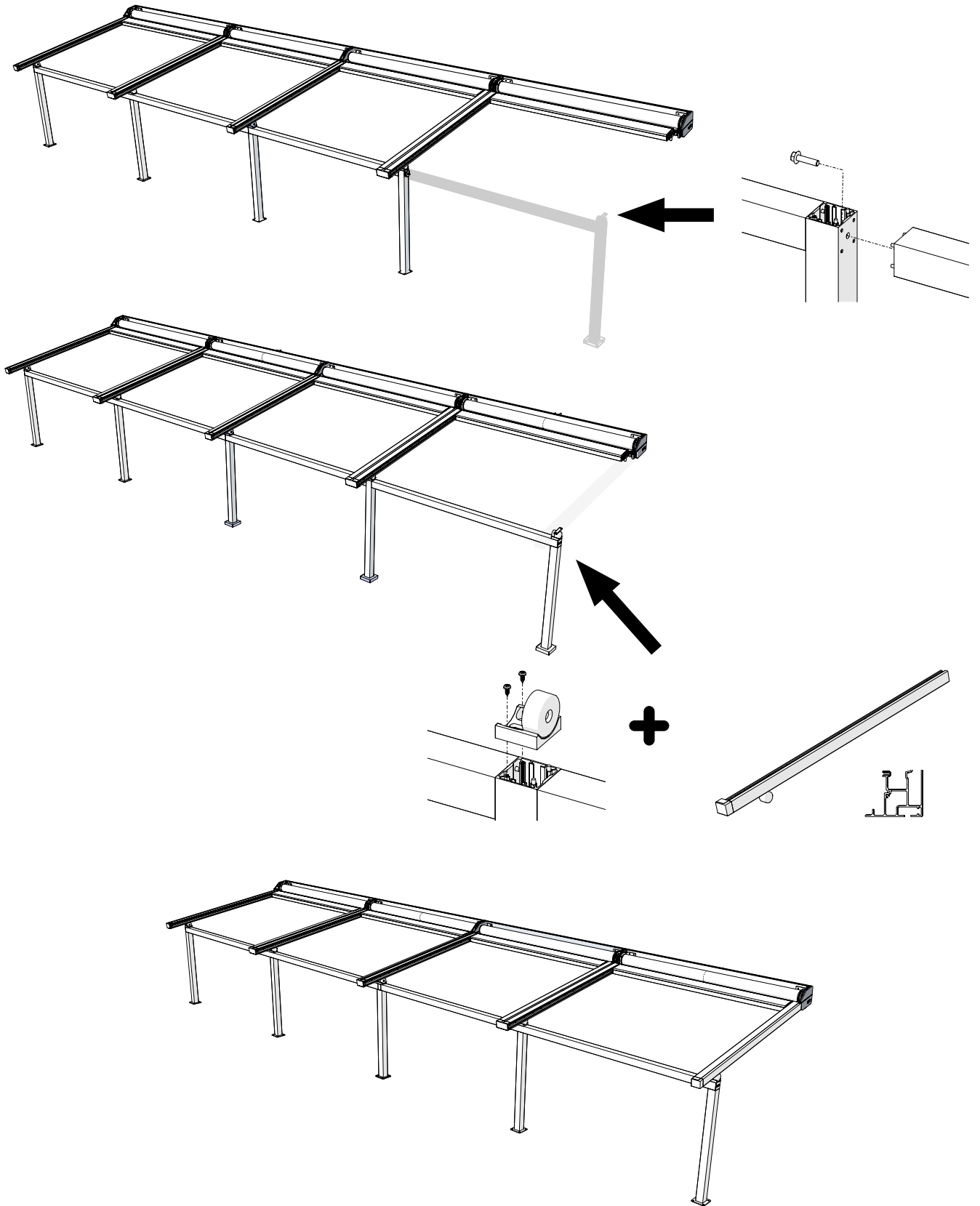

6

7

zie p.9 - p.20  
voir p.9 - p.20  
see p.9 - p.20  
sehen p.9 - p.20

.....



18

OPTIE - MUURAANSLUITING  
 OPTION - RACCORD MURAL  
 OPTION - WALL INSERT  
 OPTION - MAUERANSCHLUSS

A1552

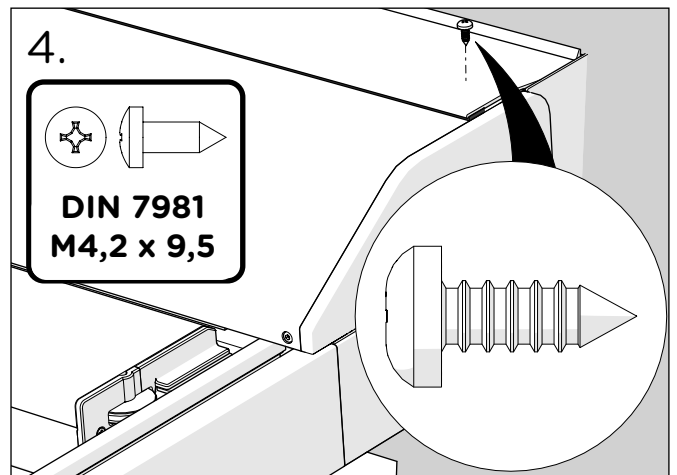
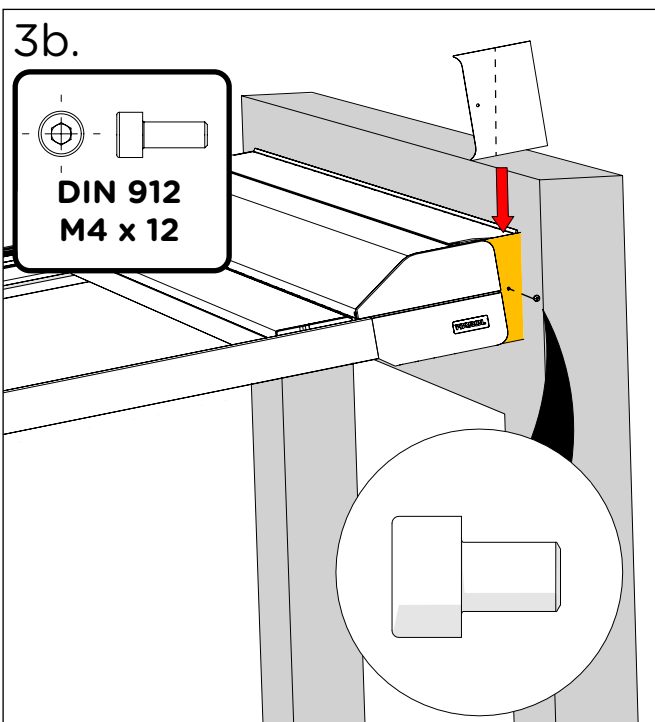
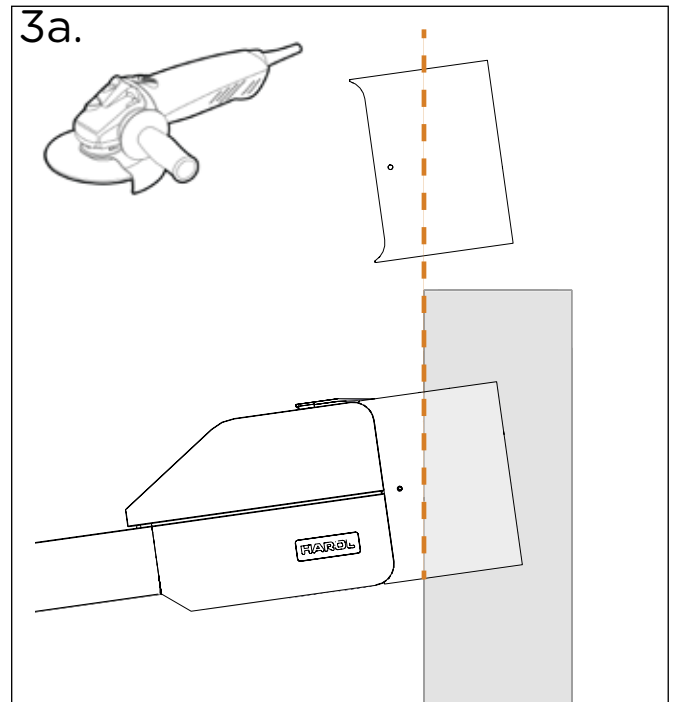
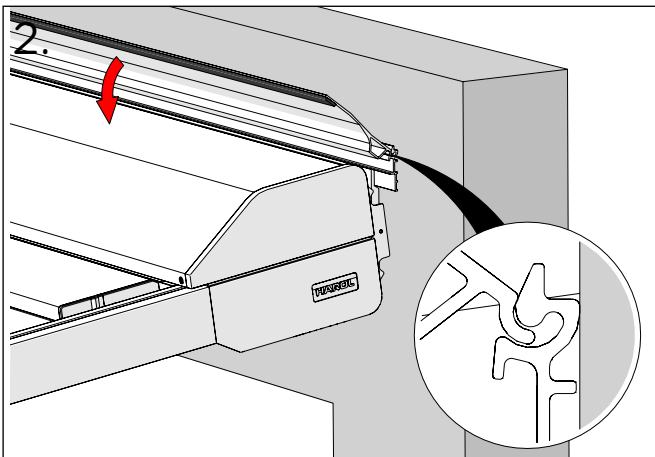
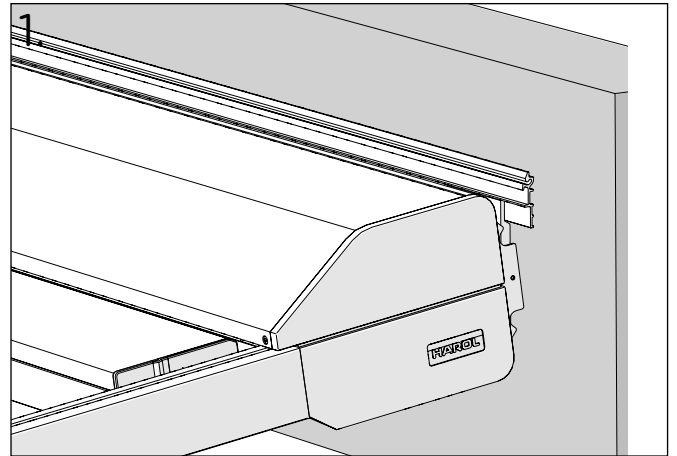
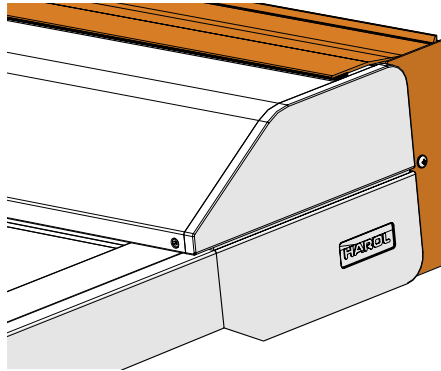

OPTIE - DOEKONDERSTEUNING  
 OPTION - LE SUPPORT DE LA TOILE  
 OPTION - FABRIC ROLLER SUPPORT  
 OPTION - TUCHWELLENUNTERSTÜTZUNG

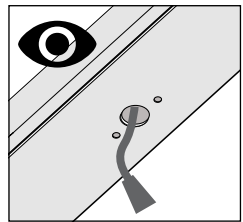
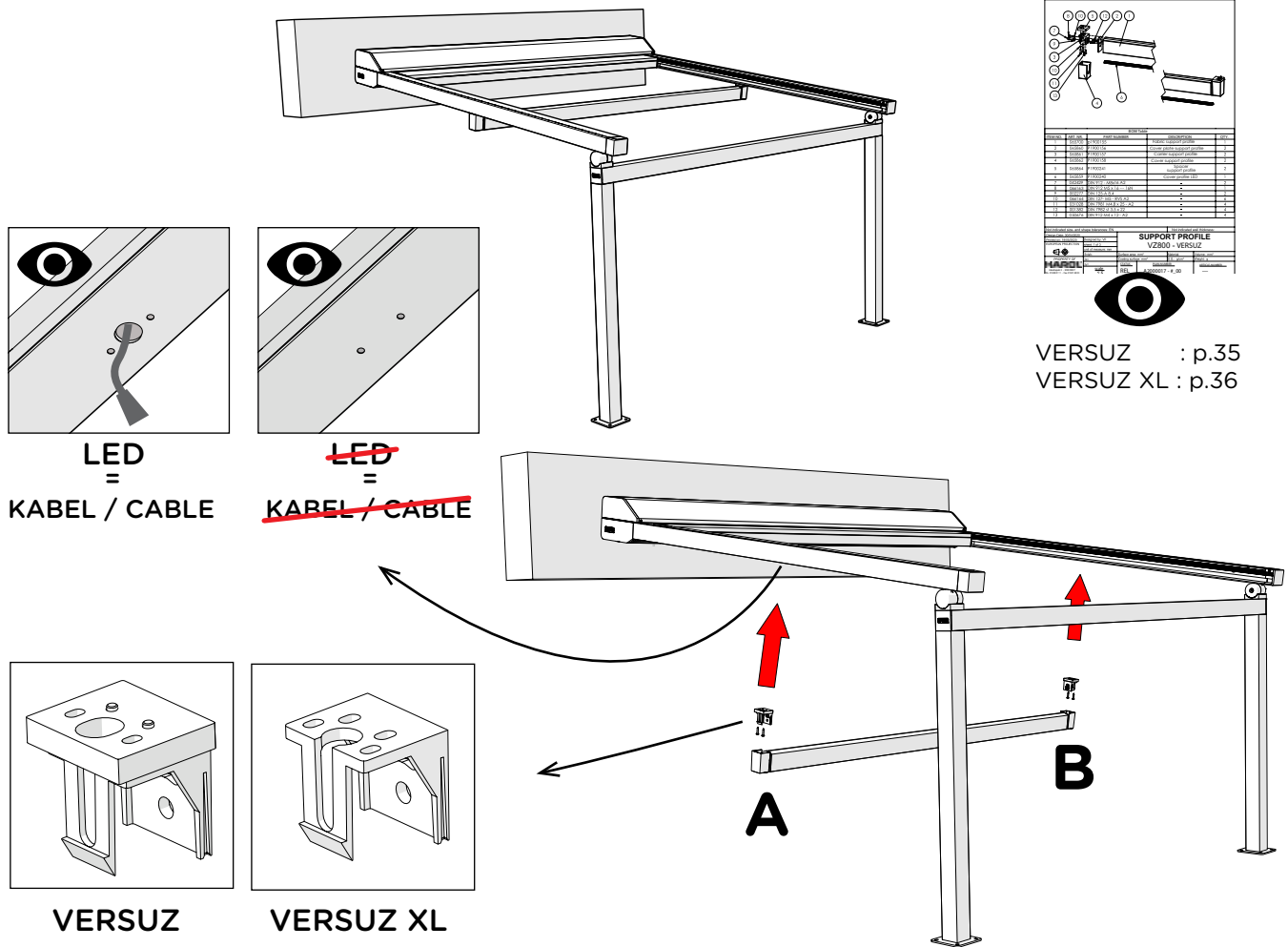

LED

KABEL / CABLE

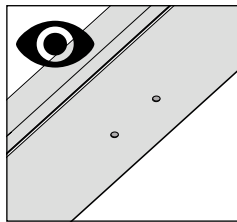

~~LED~~

~~KABEL / CABLE~~

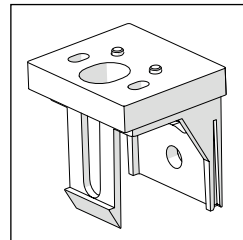

VERSUZ

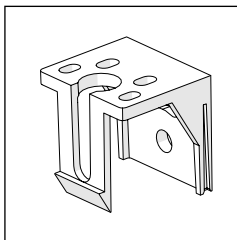

VERSUZ XL

1. A + B

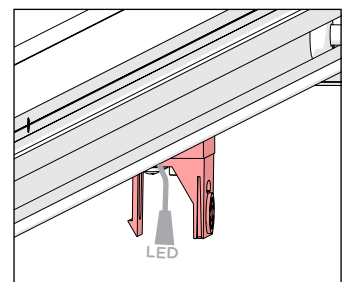
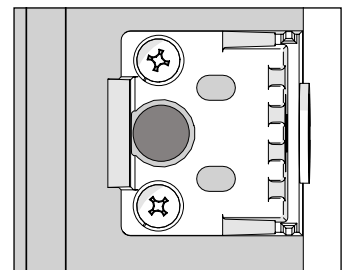
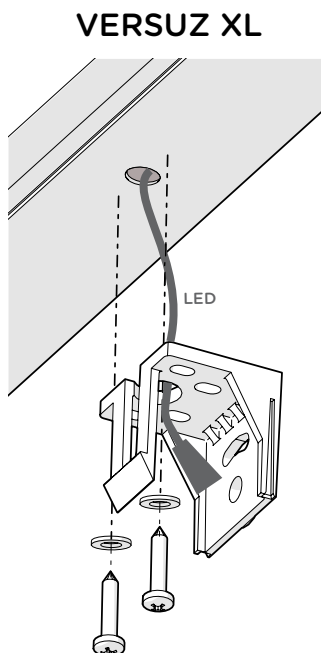
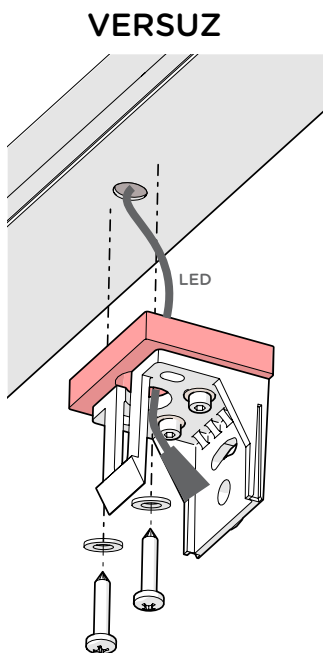
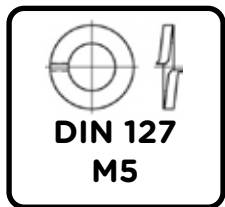
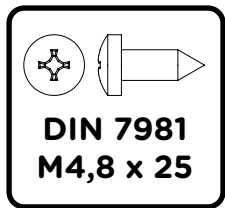

2.

A + B

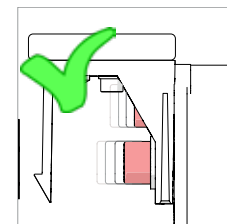
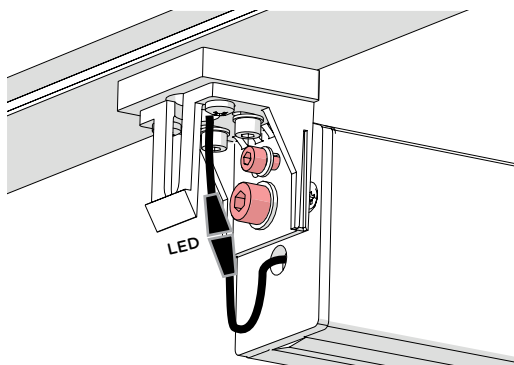
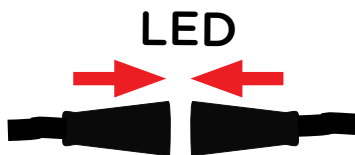
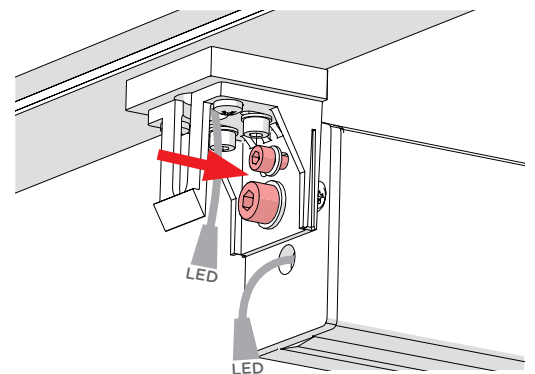
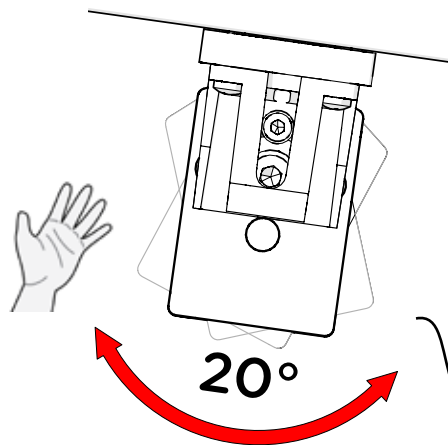
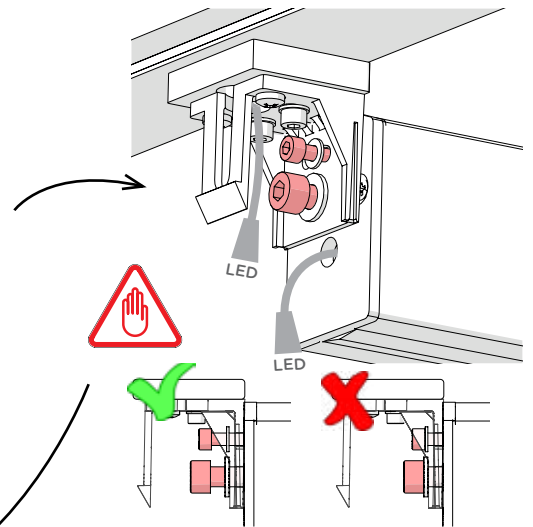
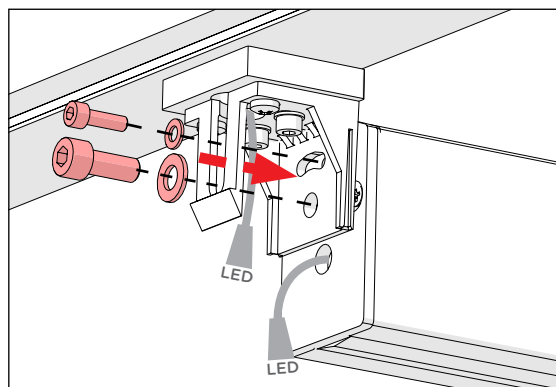
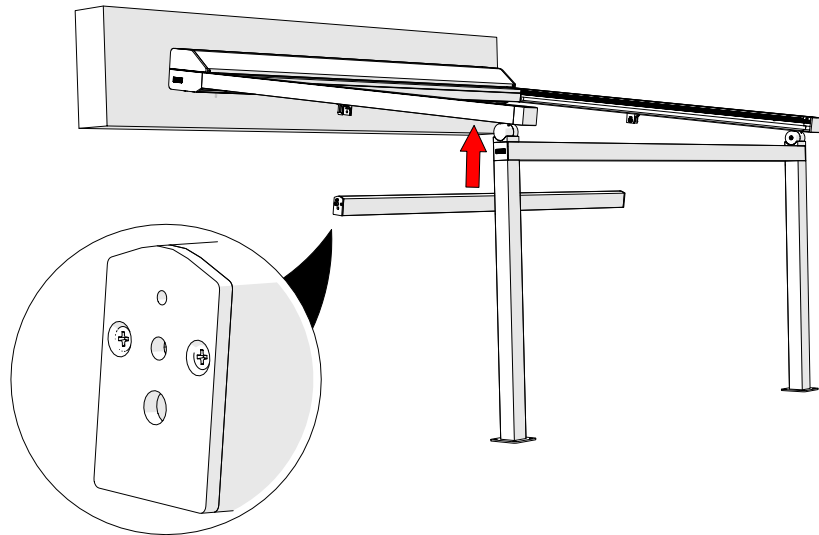
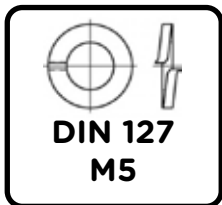
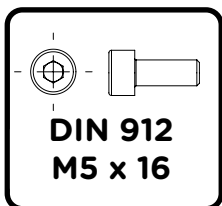
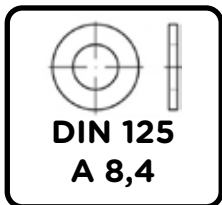
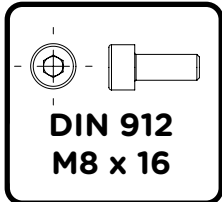
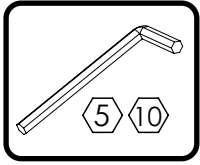

3. A + B

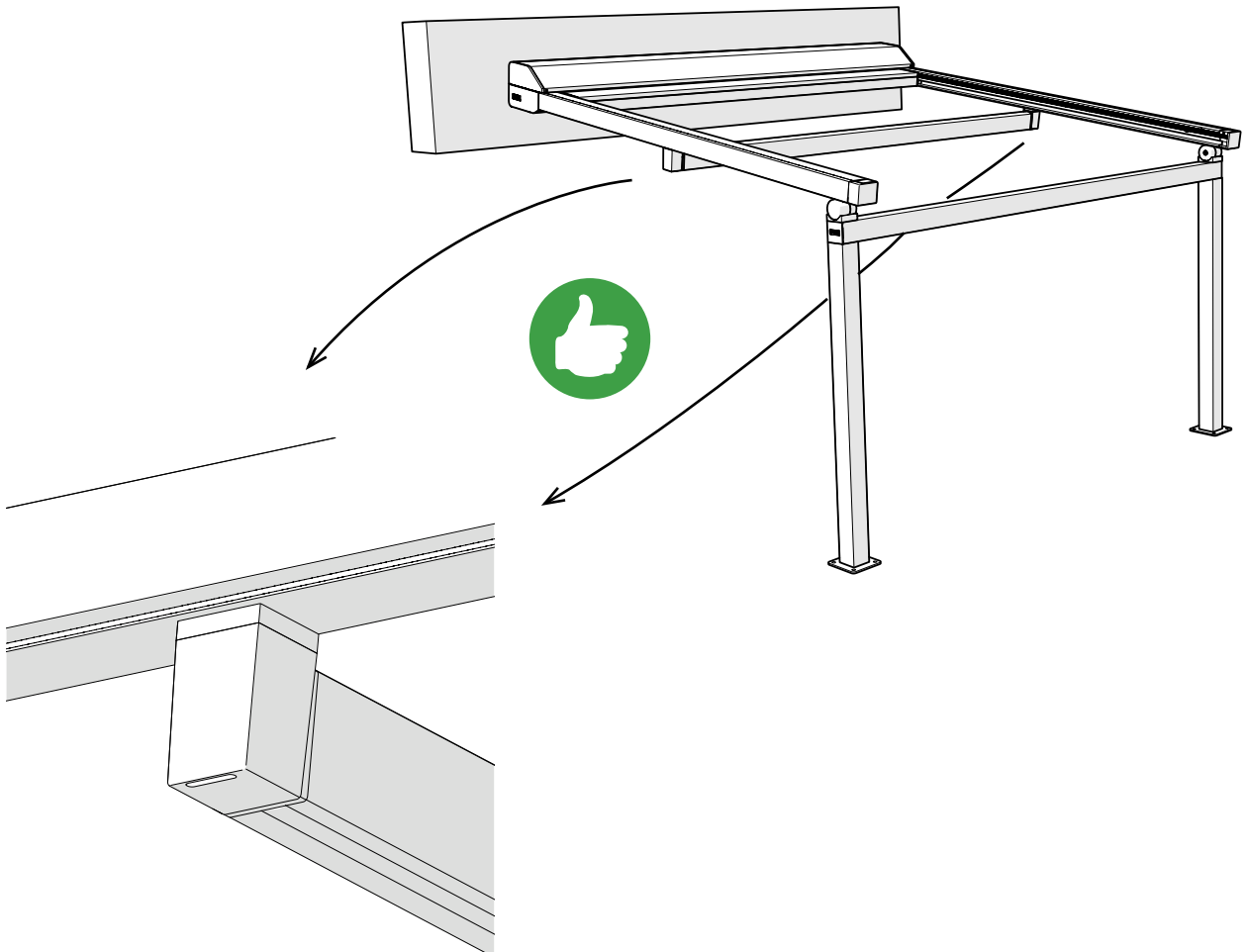
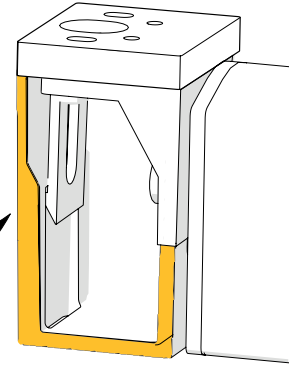
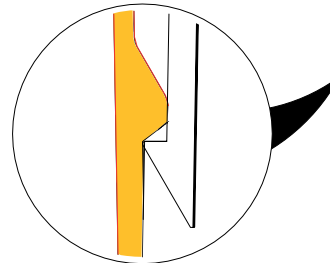
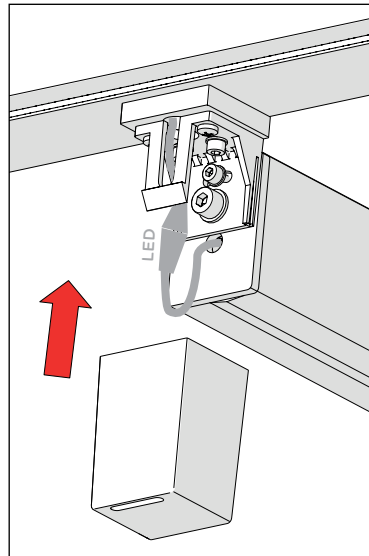
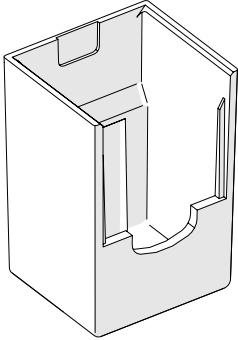
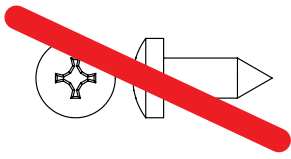

# VERSUZ (U ≤ 4000mm)

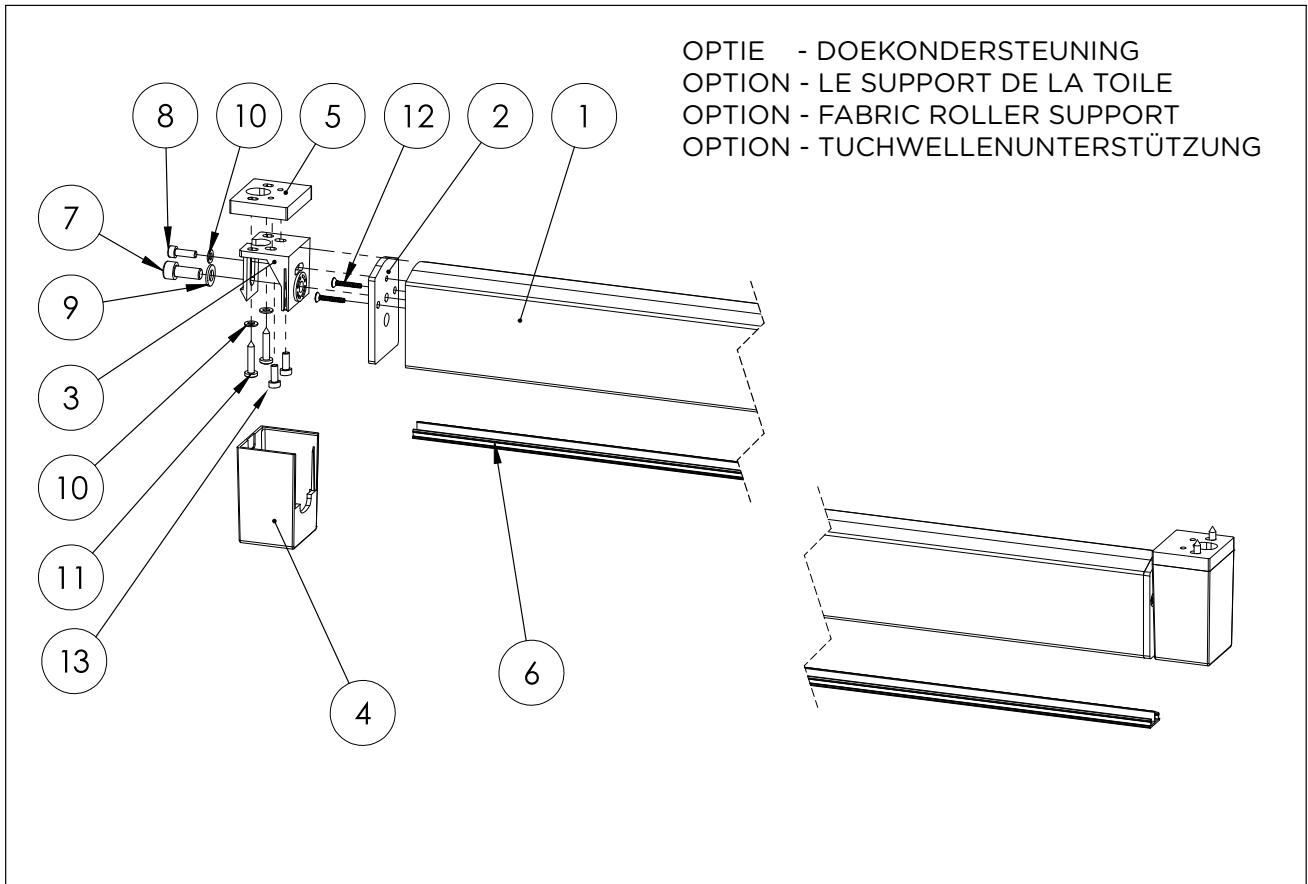

OPTIE - DOEKONDERSTEUNING  
 OPTION - LE SUPPORT DE LA TOILE  
 OPTION - FABRIC ROLLER SUPPORT  
 OPTION - TUCHWELLENUNTERSTÜTZUNG

BOM Table

ITEM NO.	ART. NR.	PART NUMBER	DESCRIPTION	QTY.
1	065700	p1900155	Fabric support profile	1
2	065860	P1900156	Cover plate support profile	2
3	065861	P1900157	Carrier support profile	2
4	065862	P1900158	Cover support profile	2
5	065864	P1900241	Spacer support profile	2
6	065859	P1900240	Cover profile LED	1
7	042429	DIN 912 - M8x16 A2	-	2
8	066163	DIN 912 M5 x 16 --- 16N	-	1
9	002277	DIN 125-A 8.4	-	2
10	066164	DIN 127- M5 - RVS A2	-	6
11	031028	DIN 7981 M4,8 x 25 - A2	-	4
12	001382	DIN 7982 st 3,5 x 22	-	4
13	050676	DIN 912 M4 x 12 - A2	-	4

Not indicated size- and shape tolerances: EN

Not indicated wall thickness:

Design Date: 30/04/2020

Printed on: 19/05/2020

EUROPEAN PROJECTION

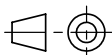

Designed by: VF

sheet: 1 of 3

unit of measure: mm

finish:

Surface area: mm<sup>2</sup>

Material:

Volume: mm<sup>3</sup>

Coating surface: mm<sup>2</sup>

S.G.: g/cm<sup>3</sup>

Weight: g

PROPERTY OF  
**HAROL**  
 Industriepark 3 - 3290 DIEST  
 TEL. 013/38 01 11 - Fax. 013/31 48 03

ly=  
 scale  
 1:5

STATUS

REL

PLAN-NUMBER

A2000017 - #\_00

ARTICLE-NUMBER

---

## SUPPORT PROFILE VZ800 - VERSUZ



# VERSUZ XL (U >= 4000mm)

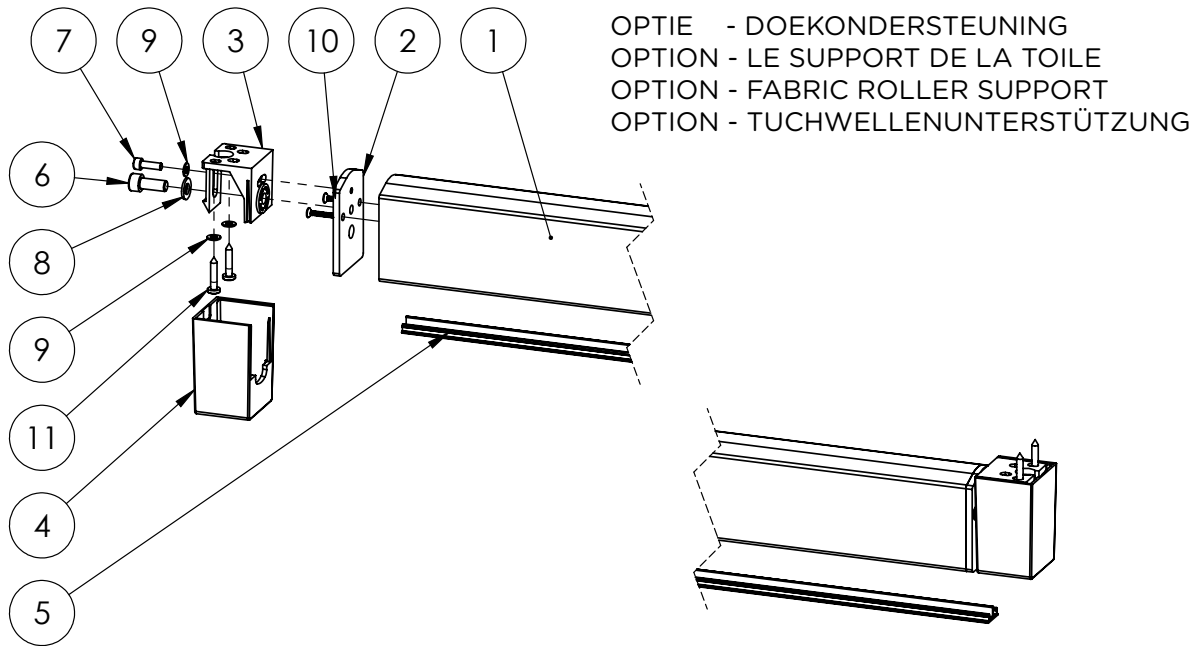

BOM Table

ITEM NO.	ART. NR.	PART NUMBER	DESCRIPTION	QTY.
1	065700	p1900155	Fabric support profile	1
2	065860	P1900156	Cover plate support profile	2
3	065861	P1900157	Carrier support profile	2
4	065862	P1900158	Cover support profile	2
5	065859	P1900240	Cover profile LED	1
6	042429	DIN 912 - M8x16 A2	-	2
7	066163	DIN 912 M5 x 16 --- 16N	-	2
8	002277	DIN 125-A 8.4	-	2
9	066164	DIN 127- M5 - RVS A2	-	6
10	001382	DIN 7982 st 3,5 x 22	-	4
11	031028	DIN 7981 M4,8 x 25 A2	-	4

Not indicated size- and shape tolerances: EN

Not indicated wall thickness:

Design Date: 30/04/2020

Printed on: 19/05/2020

EUROPEAN PROJECTION

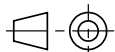

Designed by: VF

sheet: 2 of 3

unit of measure: mm

finish:

## SUPPORT PROFILE Versuz XL

Surface area: mm<sup>2</sup>

Material:

Volume: mm<sup>3</sup>

Coating surface: mm<sup>2</sup>

S.G.: g/cm<sup>3</sup>

Weight: g

PROPERTY OF  
**HAROL**<sup>®</sup>  
Industriepark 3 - 3290 DIEST  
TEL. 013/38 01 11 - Fax. 013/31 48 03

lx=

ly=

scale  
1:5

STATUS

**REL**

PLAN-NUMBER

**A2000017 - #\_00**

ARTICLE-NUMBER

---



**ELECTRISCHE SCHEMA'S  
SCHEMAS ELECTRIQUE  
ELECTRICAL SCHEMES  
ELECTRISCHES SCHEMAS**

IO LED - aansluiting / raccordement / connection / Verbindung

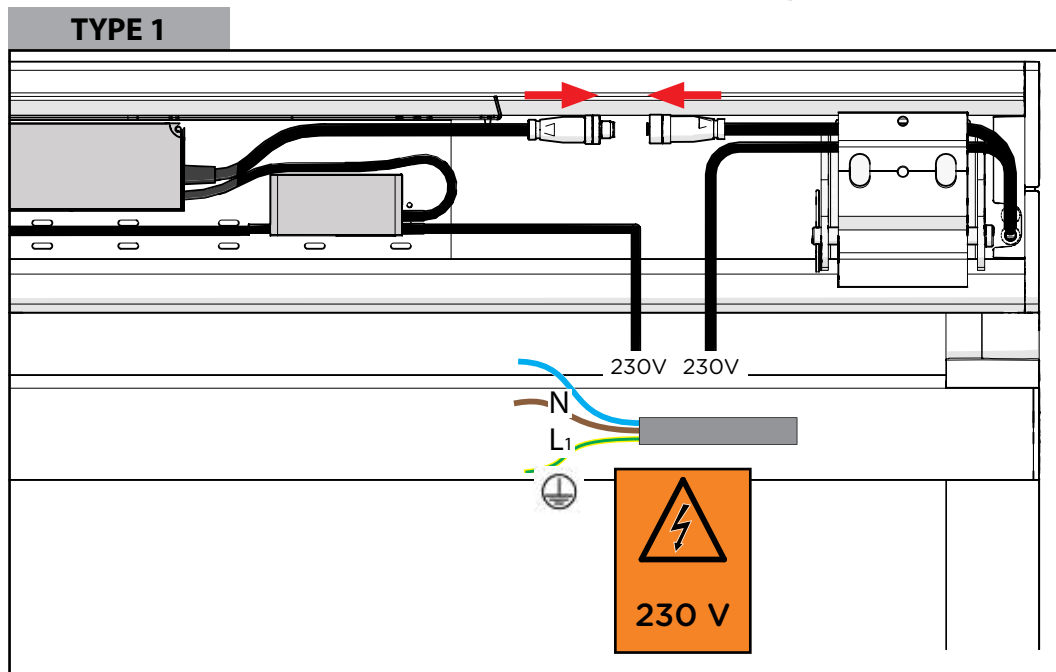
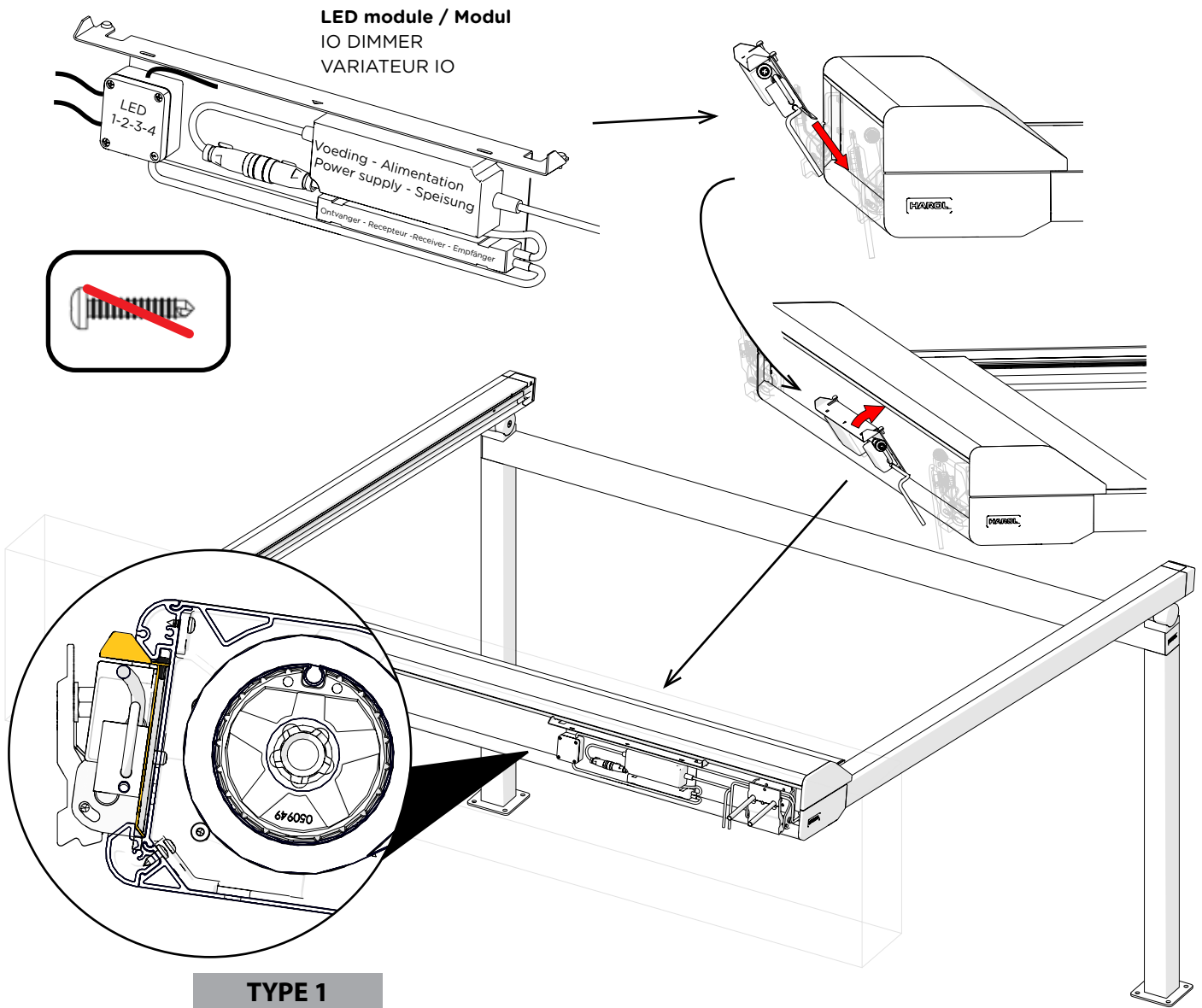

ELECTRISCHE SCHEMA'S - SCHEMAS ELECTRIQUE - ELECTRICAL SCHEMES - ELECTRISCHES SCHEMAS

IO LED - DIMBAAR / VARIATEUR / DIMMABLE / DIMMBAR

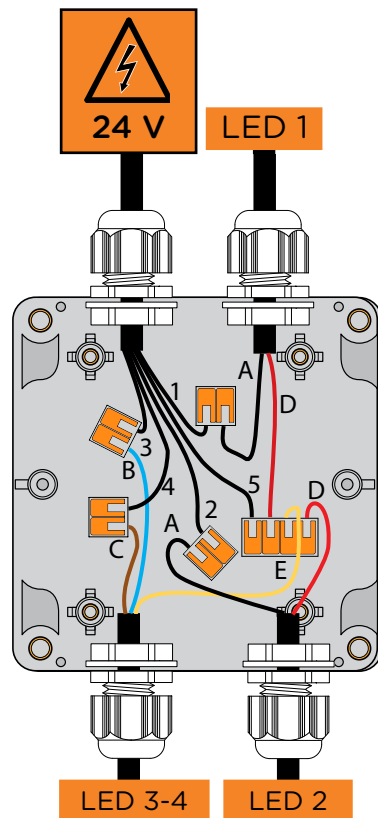
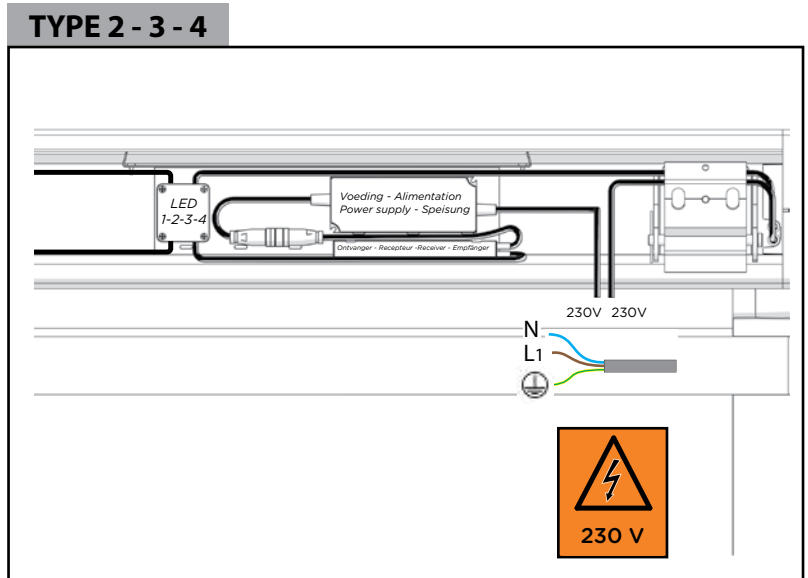
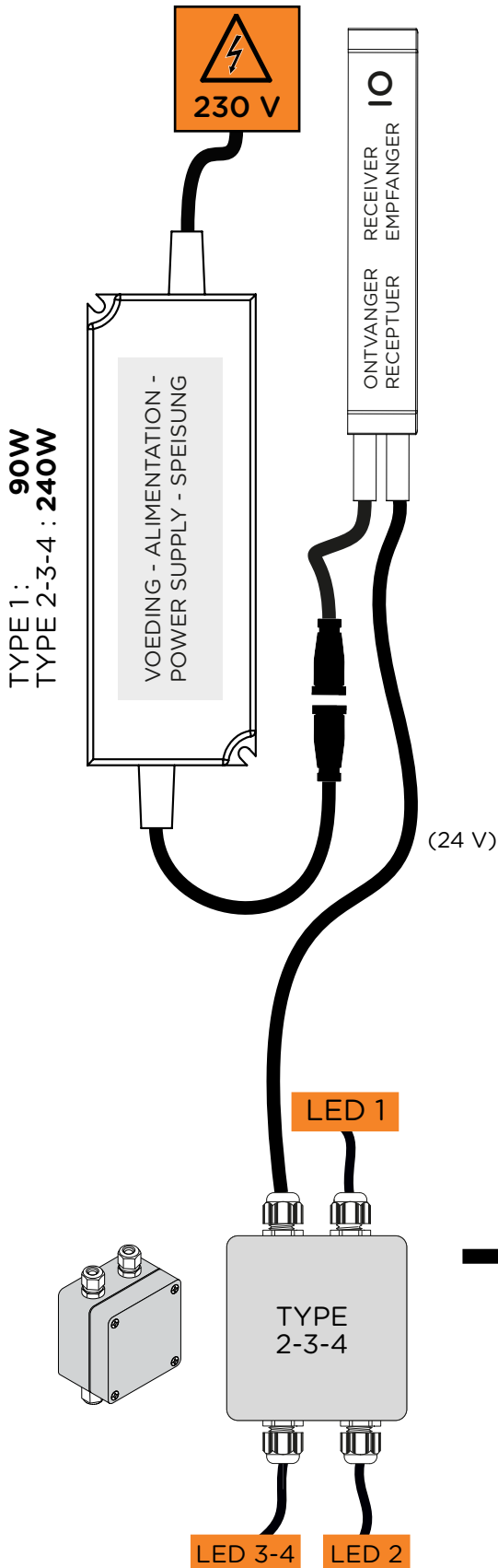

- A: zwart / noir / black / Schwarz
- B: grijs / gris / grey / Grau
- C: bruin / brun / brown / Braun
- D: rood / rouge / red / Rot
- E: geel / jaune / yellow / Gelb

RTS LED - aansluiting / raccordement / connection / Verbindung

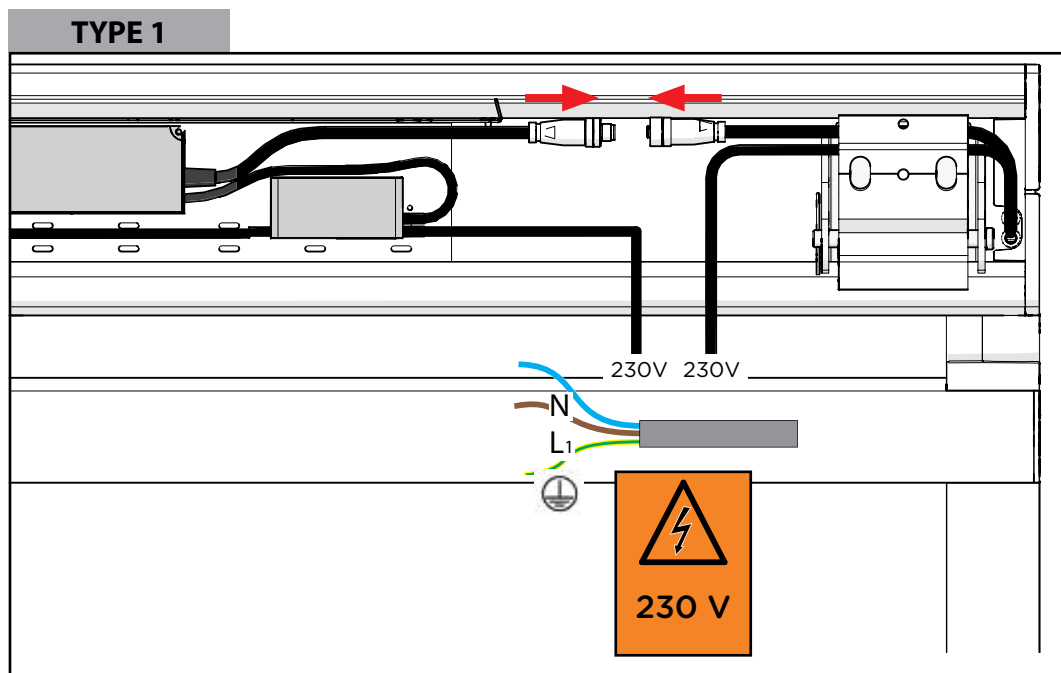
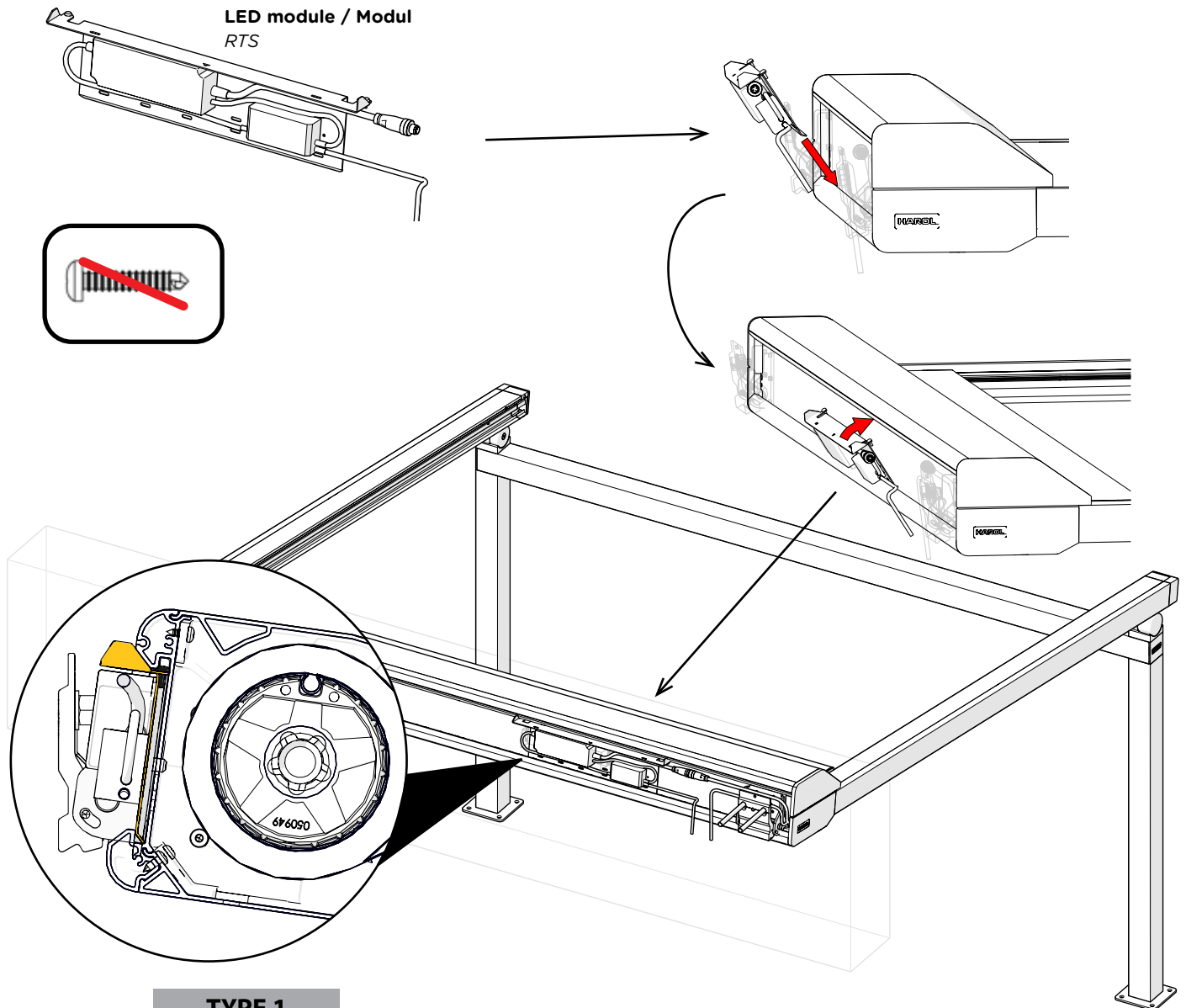

ELECTRISCHE SCHEMA'S - SCHEMAS ELECTRIQUE - ELECTRICAL SCHEMAS - ELECTRISCHES SCHEMAS

RTS  
LED

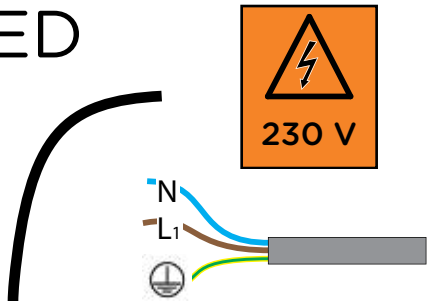

TYPE 2 - 3 - 4

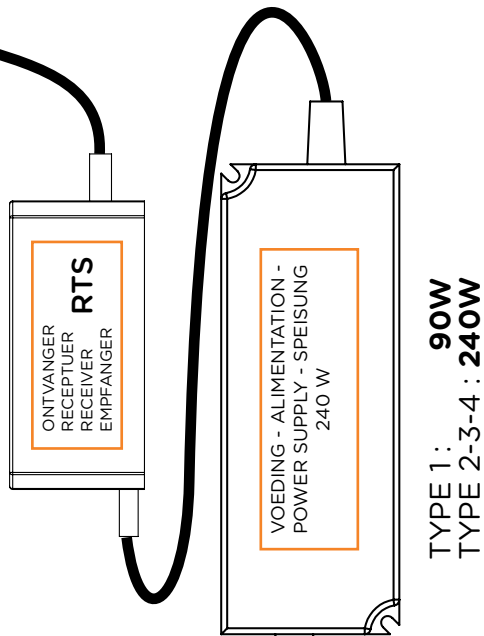
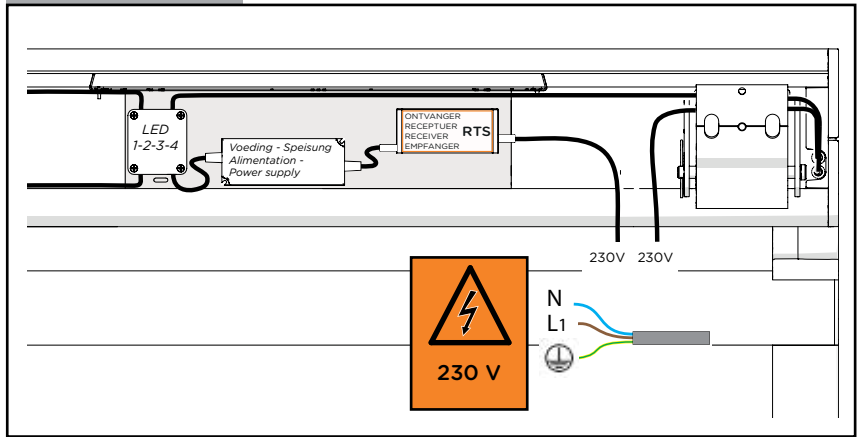

TYPE 1: 90W  
TYPE 2-3-4: 240W

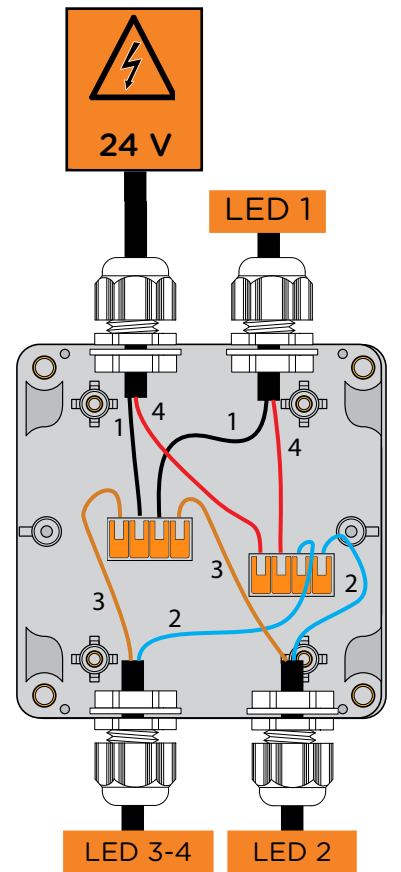
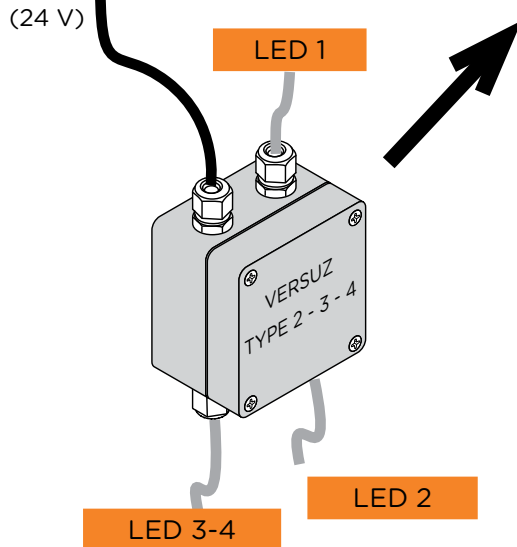

- 1: zwart / noir / black / Schwarz
- 2: blauw / bleu / blue / Blau
- 3: bruin / brun / brown / Braun
- 4: rood / rouge / red / Rot

