



OPERATING  
MANUAL

**slee** solutions  
for  
pathology

CRYOSTAT  
**MEV +**

ROUTINE CRYOSTAT

DESIGN &  
MANUFACTURING  
MADE IN GERMANY



# CONTENTS

<b>1. INTENDED USE</b>	.....	<b>4</b>
<b>2. SYMBOLS</b>	.....	<b>4</b>
<b>3. SAFETY NOTES</b>	.....	<b>4</b>
<b>4. COMPONENTS</b>	.....	<b>8</b>
<b>5. SPECIFICATIONS</b>	.....	<b>9</b>
<b>6. UNPACKING AND INSTALLATION</b>	.....	<b>11</b>
<b>7. INITIAL OPERATION</b>	.....	<b>15</b>
<b>8. OPERATION OF MICROTOME</b>	.....	<b>21</b>
<b>9. OPERATION OF CRYOSTAT</b>	.....	<b>30</b>
<b>10. CLEANING AND MAINTENANCE</b>	.....	<b>35</b>
<b>11. SERVICE</b>	.....	<b>38</b>
<b>12. OPTIONAL ACCESSORIES</b>	.....	<b>39</b>
<b>13. WARRANTY</b>	.....	<b>40</b>
<b>14. DISPOSAL</b>	.....	<b>40</b>

## 1. INTENDED USE

The floor standing open top cryostat MEV + is intended for rapid freezing and cutting thin sections of frozen specimens for professional use in routine and research laboratories in the fields of biology, medicine and industry.

The system of knife advance operates very reliable from 0.5 to 100 µm with trimming function up to 750 µm. The quality of cutting of this microtome is increased by the automatic retraction during the upstroke of the specimen, which avoids rubbing on the disposable blades or microtome knives. This stops rapid deterioration of the disposable blade or microtome knife.

## 2. SYMBOLS



Dangers, warnings and cautions are marked by this symbol



Special instructions regarding the operation of the instrument are marked by this symbol



Mechanical components that can lead to injuries during operation are marked with this symbol.



Symbol "flammable freezing sprays are prohibited"

## 3. SAFETY NOTES

The Slee open top cryostat MEV + is provided with the following safety features:

**Hand wheel stop**

**Finger protection for Knife- and blade-holder**

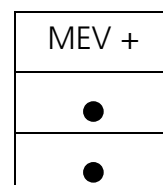

The institution which owns the unit and the persons working with the unit, servicing or repairing it have the responsibility for a hazard-free use.

### 3.1 Hand wheel stop

Always use the finger protection with the knife-/blade holder and put hand wheel in stop position

- before working with the knife or specimen
- before changing the specimen
- during break time

The hand wheel can be stopped in any position. For this purpose move the stop lever towards the centre.

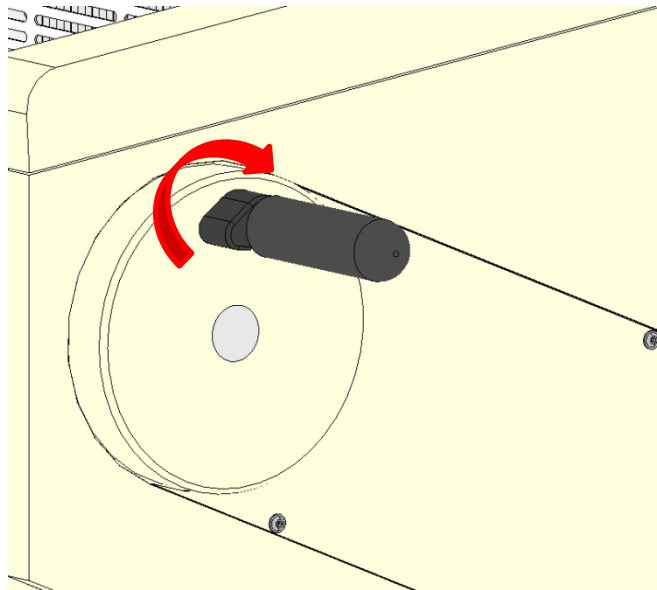

Hand wheel stop released. Movement.

To release the stop, please turn the lever towards the outside again.

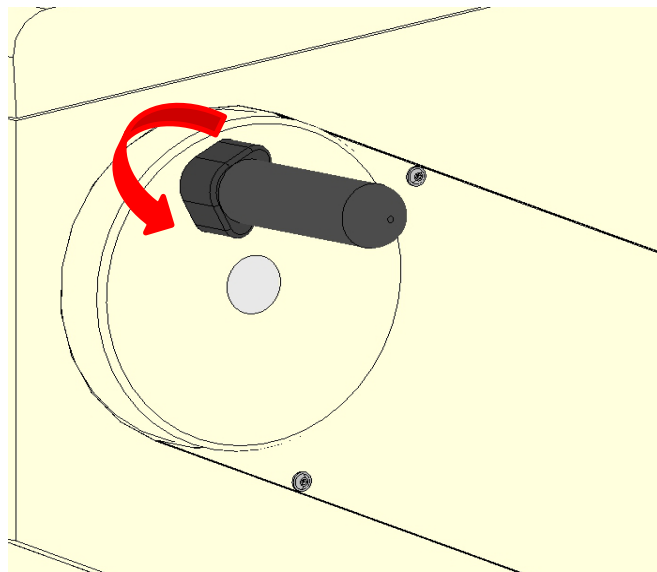

Hand wheel stop activated. No movement.

### 3.2 FINGER PROTECTION

**Always** use the finger protection

- Before you start any work with the knife or specimen
- Before changing the specimen
- During work break

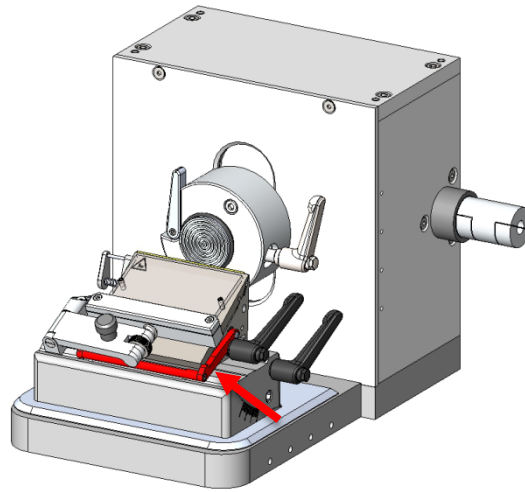

Finger protection released.

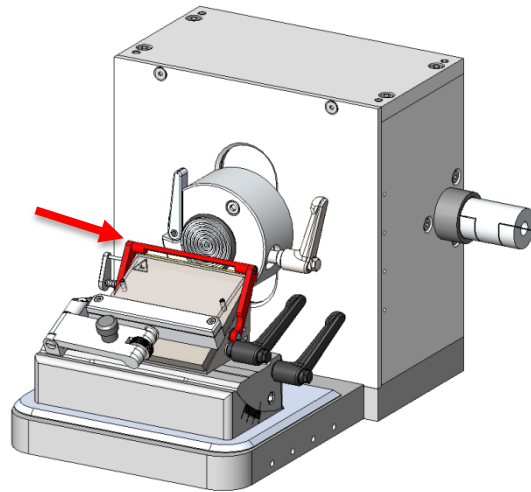

Finger protection activated.

### 3.3 ELECTRICAL POWER CONNECTION

Do not use any extension lead.



Make sure that electric power is constant. Make sure that electric power is constant. Please note that the compressor requires a start-up current between 25 and 35 A. The electric circuit at the installation site must be inspected by an electrical engineer to ensure that it meets the requirements for a smooth operation of the instrument.

- This should be examined during installation of the unit by a competent person
- Use a dedicated fuse for the unit
- Do not connect another unit to the same power circuit.
- Before turning on the instrument, check if the voltage of the mains supply is identical with the name plate of the unit

### 3.4 WORKING WITH KNIVES AND DISPOSABLE BLADES

Microtome knives and disposable blades have extremely sharp edges and this can lead to injuries.

Please be extremely careful when handling microtome knives and disposable blades.



Do not place microtome knives or disposable blades at unsecured areas.

Never position microtome knives or disposable blades with the sharp edge pointing upwards.

Store blades in a covered container. Use a container that has guides to hold the blades rigid.

Never try to catch a falling microtome knife.

Always insert the specimen first and then the microtome knife or disposable blade.

To avoid compression or knife marks, ensure that the blade is clean.

## 4. COMPONENTS

The Slee open top cryostat MEV + is provided with the following standard components:

	MEV +
<b>Basic unit with refrigeration system</b>	•
<b>Semi-automatic rotary microtome</b>	•
<b>Operation manual</b>	•
<b>Specimen holder</b> (5x Ø 22mm; 5x Ø 35 mm)	•
<b><i>clear-cut</i> Brush</b>	•
<b>Object cooling</b>	•
<b>Quick-freeze</b>	•
<b>UV disinfection</b>	•
<b>Anti-roll plate</b> (ready to use)	•
<b>1x Bottle cryostat low temperature oil</b>	•
<b>4x 125 ml CryoGlue embedding medium</b>	•
<b>1 Box of disposable blades (50 pcs.) or 1 steel knife (16 cm C-profile)</b>	•
<b>1 Set of allen key, socket wrench and screwdriver</b>	•
<b>1x Heat Extractor</b>	•
<b>1x Mains cable</b>	•
<b>2x Cover plug (black) für base</b>	•



## 5. SPECIFICATIONS MEV +

### General

Nominal power	230 V AC +/-10%	115 V AC +/-10%
Nominal frequency	50 / 60 Hz	60 Hz
Power	1.350 VA	1.350 VA
Max. current for 5 sec	17 A	35 A
Protective class	I	I
Fuses	2 * T 10 A	2 * T 20 A
Pollution class	2	2
Overcurrent protective class	II	II
Max. heat energy	1.360 J/s	1.360 J/s
Operating temperature range	+10 to +35 °C	
Operating humidity	max. rel. 80 % non-condensing	
Storage temperature range	+5 to +55 °C	
Storage humidity	max. rel. 80 % non-condensing	

### Cryochamber

Temperature range	0°C to -35°C, selectable in 1 K steps, environment: 20°C	
Cooling power	640 W	514 W
Switch off pressure	25 bar	25 bar
Current	3,69 A	6,45 A
Cooling gas	R 449 A, 320 g	R 449 A, 320 g

### Chamber defrost

Automatic defrost	hot gas defrost, time selectable, 1-3 times per day or manual defrost on request
Automatic stop	at -5 °C chamber temperature

### Freezing bar

Minimal temperature	10 K lower than chamber temperature
Number of positions	21 + 2
Quick freeze positions	2, to -55 °C (Peltier cooling)

## **Microtome**

Type	rotary microtome, incapsulated
Thickness range	0.5 – 100 $\mu\text{m}$
Thickness settings	0 – 2 $\mu\text{m}$ in 0.5 $\mu\text{m}$ steps 2 – 20 $\mu\text{m}$ in 1 $\mu\text{m}$ steps 20 – 50 $\mu\text{m}$ in 2 $\mu\text{m}$ steps 50 – 100 $\mu\text{m}$ in 5 $\mu\text{m}$ steps
Horizontal movement	28 mm
Vertical movement	58 mm
Retraction during upward stroke	0 – 200 $\mu\text{m}$ , free selectable (defined steps)
Trimming	0,5 – 750 $\mu\text{m}$ , free selectable (defined steps)
Specimen orientation	8° (x and y axes), 360° (z axes) Zero point detent x and y axis

## **Cryostat**

Dimensions (L x W x H)	680 mm x 760 mm x 1110 mm
Weight (without accessories)	146 kg

## 6. UNPACKING AND INSTALLATION

### 6.1 UNPACKING THE INSTRUMENT

In standard design you will receive the unit in a cardboard box standing on a wooden pallet. The unit is equipped with four castors and two feet, adjustable in height in the front.



When the instrument is delivered, check the tilt indicators and shock watches on the packaging. If tilt indicators are activated, the shipment was transported laying flat, was tilted at too great an angle or fell over during transport. If the shock watches are activated, the instrument fell over during transport. Note this on the shipping documents and check the shipment for possible damage.

Open the cardboard box from the top and remove the accessories together with the supporting foams. Then remove the cardboard box.

Remove the screws on the two fixation brackets that hold the instrument on the wooden pallet.

Swing out the ramp on which the instrument can be rolled down off the transport pallet. To ensure a safe transport two (2) people are required.

Carefully roll the instrument backwards over the ramp from the pallet and push the instrument to the installation location on the castors

Extend the two front feet to stabilize the cryostat in its position by turning the supporting screws counter clockwise.

For repacking use the original cases. Keep the packing material.

## 6.2 INSTALLATION SITE REQUIREMENTS

The site for installation for MEV + should meet the following requirements:

- A maximum ambient temperature of 22°C
- No direct sunlight into the cooling chamber
- Mains power supply within 3 m
- No air circulation (for example by air conditioning)
- Instrument may only be used inside rooms
- The mains supply should not be connected in series with other devices, such as multiple sockets - a separate circuit should be provided
- Hand wheel must be reached easily
- Relative humidity lower than 60%
- A minimum distance between wall and rear of the instrument of 10-20 cm should be guaranteed





High room temperatures and high humidity influence the cooling capacity of the instrument and will lead to ice forming inside the instrument.

## 6.3 INSTALLATION

For opening the chamber push the window to the top.

Remove the transport security underneath the specimen holder and position the waste tray.

After installation, wait at least 4 hours before switching on the instrument. Failure to comply may result in severe damage to the instrument.

<p>The device is delivered with a defrosting water collecting container, which must be installed before the device is put into operation.</p> <p>First mount the metal bracket for the defrosting water container on the right side of the device. Loosen the screws and hang the bracket in the screws. Now tighten the screws.</p>	 <p>Installation of the metal bracket for the defrost water collector.</p>
<p>Place the defrosting water container in the metal holder and connect the defrosting water pipe and the level sensor to the device.</p>	 <p>Connection of the defrost water pipe and the level sensor to the device.</p>



It is necessary to install the laterally defrost container, otherwise there may be icing on the evaporator! We recommend filling the container with 500 ml disinfectant before initial operation.

After installation, wait at least 4 hours before switching on the instrument. Failure to comply may result in severe damage to the instrument.

## 6.4 COLLAPSIBLE HANDWHEEL LEVER

The instrument is delivered with a ready to use hand wheel lever that is folded away for transport reasons.

- Before you start any work unfold the hand wheel lever by simply pulling the lever into a horizontal position.
- For folding the lever back, pull the horizontally orientated lever and fold it away.

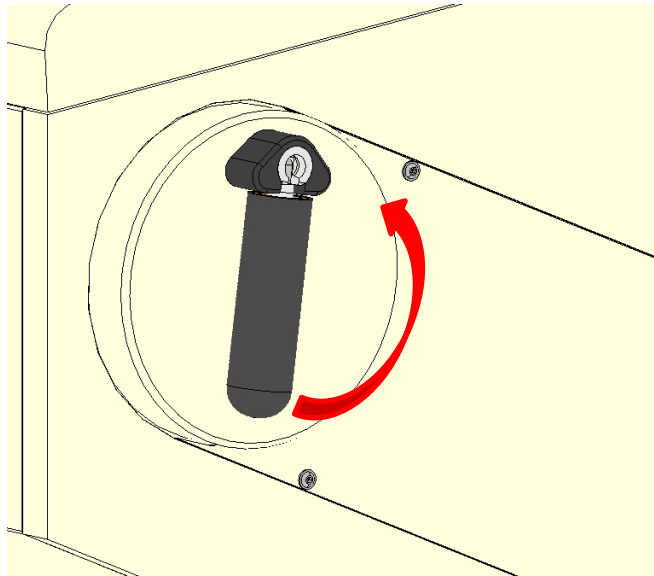

Hand wheel lever in folded position.

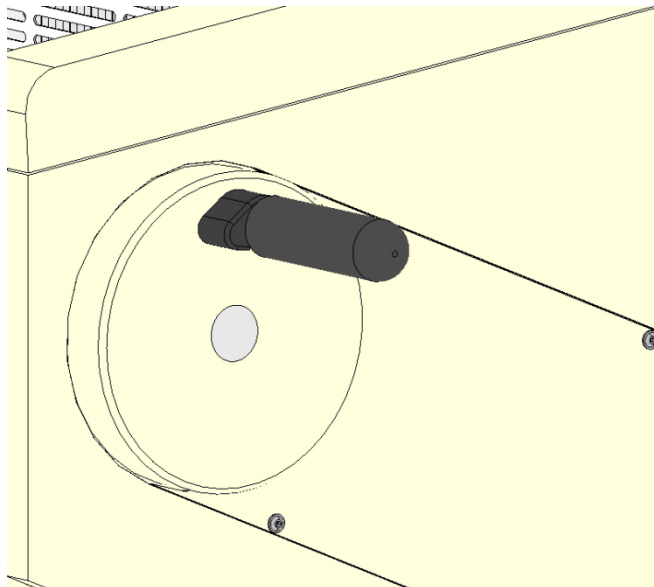

Hand wheel lever unfolded.

## 7. INITIAL OPERATION

### 7.1 MAIN DISPLAY

The main display will show the day and time, the cutting thickness, the trimming thickness, the current chamber temperature, the target chamber temperature, the status of the quick-freeze unit (optional) and the total electronic status of the instrument and a cutting counter (optional).

TUE 13:05:05	
CUT: 7 µm	Trim: 19µm
Cha: -20 °C (-22)	QF: 0
Status:OK	0000

### 7.2 CONTROL PANEL

Software settings and motor operation can be operated with the control panel on the left to side of the instrument.

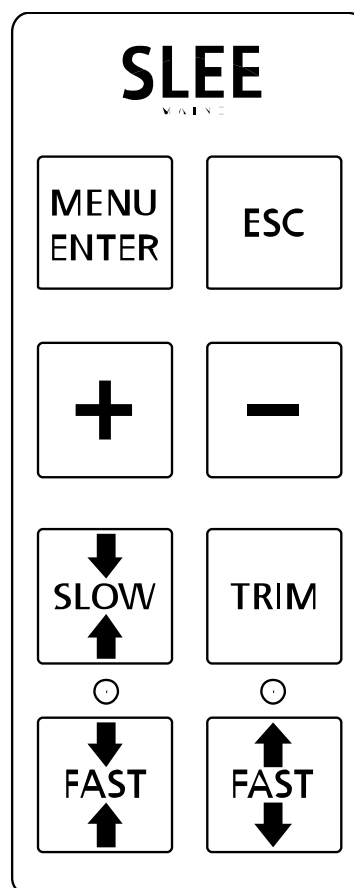

MEV + Control Panel.

### 7.3 SOFTWARE SETTINGS

Press  to open the Settings menu.

>	Chamber temp	-20 °C
	Quickfreeze	Off
	UV disinfection	
	Light	Auto

To move further down in the main menu list, press .

	Retraction	5 µm
	Start defrost	
	Contrast	
>	TIME	TUE 13:05:05

To move further up in the main menu list, Press .

>	Light	Auto
	Light duration	10 m
	Chamber incr	-15 °C
	Retraction	5 µm

To change values, select a setting.

Press  to open the setting.

Change entries by pressing  or .

Store new settings by pressing .

	Light duration	10 m
>	Chamber incr	-15 °C
	Retraction	5 µm
	Start defrost	

Press  to return to the main menu.

TUE 13:05:05	
CUT: 7 µm	Trim: 19µm
Cha: 22 °C (25)	QF: 0
Status:OK	0000



## 7.4 AUTOMATIC DEFROST, DISINFECTION AND POWER SAVING SETTINGS

Press  to open the Settings menu.

>	Chamber temp	-20 °C
	Quickfreeze	Off
	UV disinfection	
	Light	Auto

Select Program settings and press  to open the menu for setting automatic defrost and power saving times.

	TIME	TUE	---
	Language		English
	Display version		
>	Program settings		5 µm

Enter PIN Code 5792.

PIN Code is usually restricted to service technicians or instrument administrators

	Enter PIN
	0000

Select defrosting programs 1 to 3 and set a time for the automatic defrosting programme.  
(e.g. each day at 12:00 h and at 23:00 h in this example)

>	Deifr. Start 1	12:00
	Deifr. Start 2	23:00
	Deifr. Start 3	__:__
	Disinf. Req.	__:__

Select temperature increase start and set a starting time for the automatic power saving mode.  
(e.g. start at 21:00 h in this example)

	Disinf. delay	10 h
>	Incr. start	21:00
	Incr. end	04:00
	Incr. days	----- 5

Select temperature increase end and set a ending time for the automatic power saving mode.  
(e.g. end at 04:00 h in this example)

	Disinf. delay	10 h
	Incr. start	21:00
>	Incr. end	04:00
	Incr. days	----- 5 6

Select temperature increase days and set the days at that the automatic power saving mode will be active for 24 hours.  
(e.g. Fridays and Saturdays in this example)

Disinf. delay	1 2 _ _ _ _
Incr. start	21:00
Incr. end	04:00
> Incr. days	_ _ _ _ 5 6 _

1-Monday 2-Tuesday 3-Wednesday 4-Thursday 5-Friday 6-Saturday 7-Sunday

**Settings for disinfection parameters:**

The disinfection cycle works in a semi-automated way.  
First select a time when the system will ask for a disinfection cycle.  
(e.g. at 12:00 h the instrument will ask for a disinfection cycle).

> Disinfec. Req.	12:00
Disin. Days	1 2 _ _ _ _
Disin. Delay	10 h

Select the days in which a disinfection cycle can be activated.  
(e.g. Monday and Tuesday in this example)

Disinfec. Req.	12:00
> Disin. Days	1 2 _ _ _ _
Disin. Delay	10 h



1-Monday 2-Tuesday 3-Wednesday 4-Thursday 5-Friday 6-Saturday 7-Sunday

Select the delay time at which the disinfection cycle will be activated.  
(e.g. 10 hours)  
After confirmation the disinfection cycle will start at 10 p.m.

Disinfec. Req.	12:00
Disin. Days	1 2 _ _ _ _
> Disin. Delay	10 h

## 7.5 List of available software settings

<b>Chamber temperature</b>	-35 °C to ambient The recommended working temperature is -15 °C to -25 °C
<b>Object cooling</b>	ON / OFF  If the instrument is equipped with the optional object cooling system, its function can be activated or deactivated.
<b>Object temperature</b>	-50 °C to 0 °C  If the instrument is equipped with the optional object cooling system, its function can be activated or deactivated.
<b>Quick-freeze</b>	ON / OFF  If the instrument is equipped with the optional fast cooling peltier system, its function can be activated or deactivated.  The default setting for automatic deactivation of the quick freeze is set to 30 minutes. The timer for automatic deactivation can be set by an authorized service technician.
<b>UV disinfection</b>	ON /OFF  If the instrument is equipped with the optional UV-C disinfection system, its function can be activated or deactivated.  The default setting for automatic deactivation is set to 30 minutes. The timer can be set by an authorized service technician.
<b>Light</b>	ON / OFF / AUTO  The light can be set on or off. If AUTO has been selected, the light will switch off after the time being set under Light duration.
<b>Light duration</b>	0 - 99 minutes

<b>Chamber Increase</b>	For power saving, a higher temperature can be set for defined times and/or days.  The selected temperature should be below 0 °C to avoid damage to the microtome by freezing moisture.
<b>Retraction</b>	0 - 200 µm
<b>Start defrost</b>	Activate  A manual defrost procedure is activated.
<b>Trim latching</b>	ON/OFF    
<b>Contrast</b>	Display contrast
<b>Time</b>	Day and Time
<b>Language</b>	A language can be selected out of a list of available languages.
<b>Display version</b>	Display of software version.
<b>Program settings</b>	Upon selecting Program settings the automatic defrost and power saving settings can be changed.

## 8. OPERATION OF MICROTOME

### 8.1 INSERTION AND ORIENTATION OF KNIFE

Activate hand wheel lock.

Loosen the knife fixation by turning two screws in front of the knife holder counter clockwise

Remove/Insert knife

Adjust knife height by turning the wheels on the left and right side of the knife holder base.

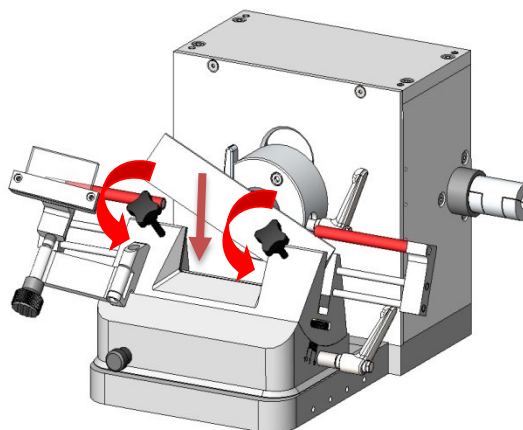

Loosening of knife fixation and insertion of new knife.

Tighten the knife fixation by turning the two screws in the front of the knife holder clockwise.

Release hand wheel lock for cutting.

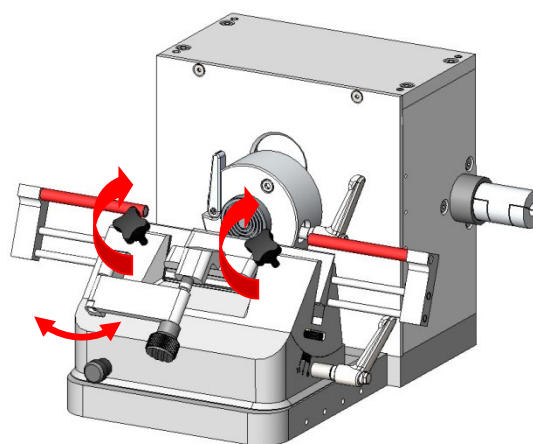

Fixation and height adjustment of knife.

## 8.2 INSERTION AND ORIENTATION OF DISPOSABLE BLADE

Activate hand wheel lock.

Remove finger protection.

Loosen the blade fixation by turning the right lever counter clockwise.

Use the blade ejector to remove the blade.

Remove/Insert blade from right side.

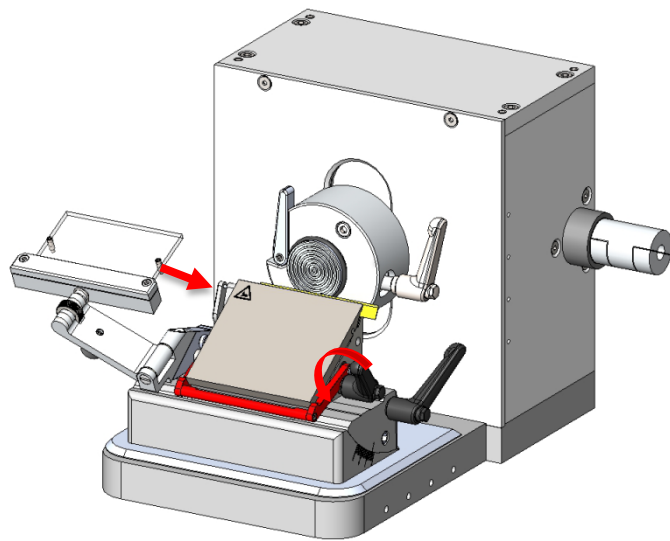

Loosening of blade fixation and insertion of new blade.

Tighten the blade fixation by turning the right lever clockwise.

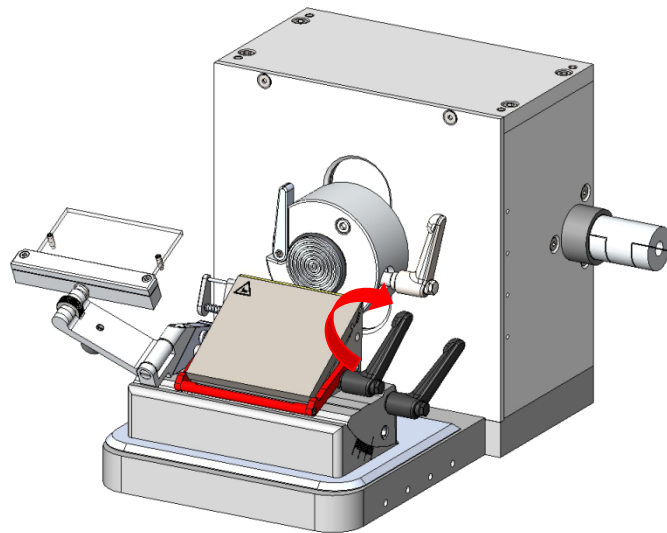

Fixation of blade.

To change the cutting angle, loosen the blade holder by turning the right lever on the blade holder base counterclockwise.

Tilting the blade holder to the sample increases the cutting angle, tilting the blade holder away from the sample reduces the cutting angle.

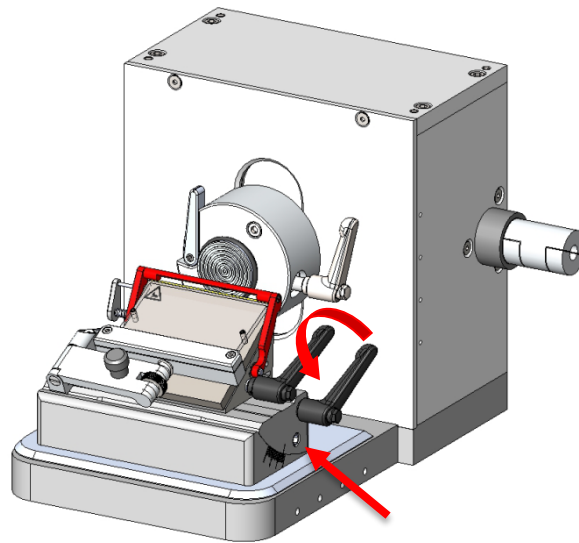

Loosening of blade holder fixation and adjusting new cutting angle (increased cutting angle).

Secure the blade holder clockwise by turning the right lever on the blade holder base.

Release the handwheel lock to cut the samples.

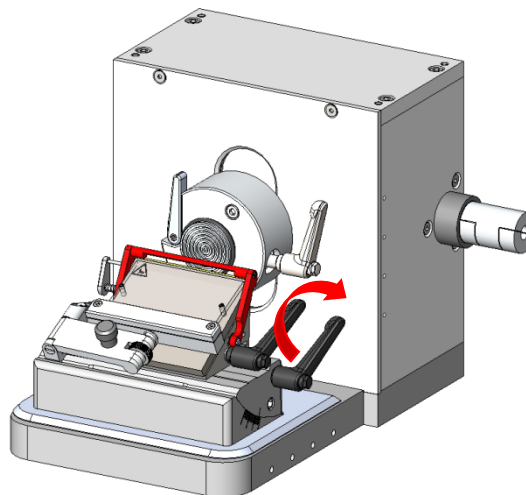

Fixation of blade holder with increased cutting angle.

### 8.3 SPECIMEN MOUNTING

The instrument is equipped with 24 freezing positions. The temperature is approx. 10 °C lower than the actual cryochamber temperature.

In order to prepare a specimen for sectioning, place the specimen holder on a freeze point, add some drops of embedding medium (e.g.GSV1) on the holder and carefully press the object on top.

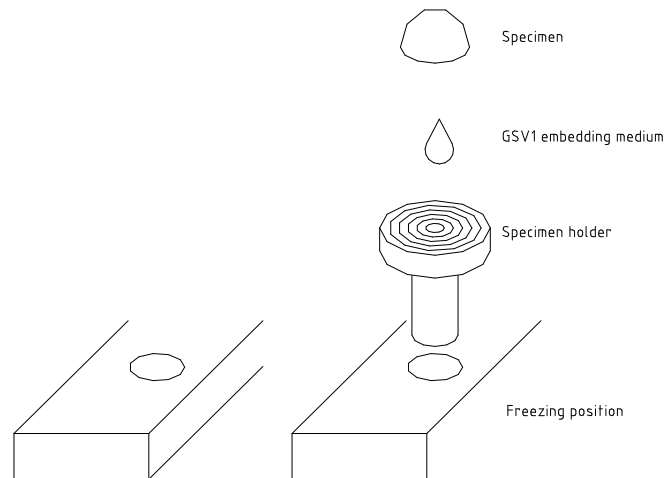

Wait until the object is frozen (mat surface or pressure).

### 8.4 INSERTION OF OBJECT HOLDER

1. Turn hand wheel to its highest position and activate the hand wheel stop.
2. Release the object holder fixation by turning the fixation lever counter clockwise.
3. Remove/Insert object holder.
4. Tighten the object holder by turning the fixation lever clockwise.

The fixation lever is limited in the range of rotation downwards due to risk of collision.

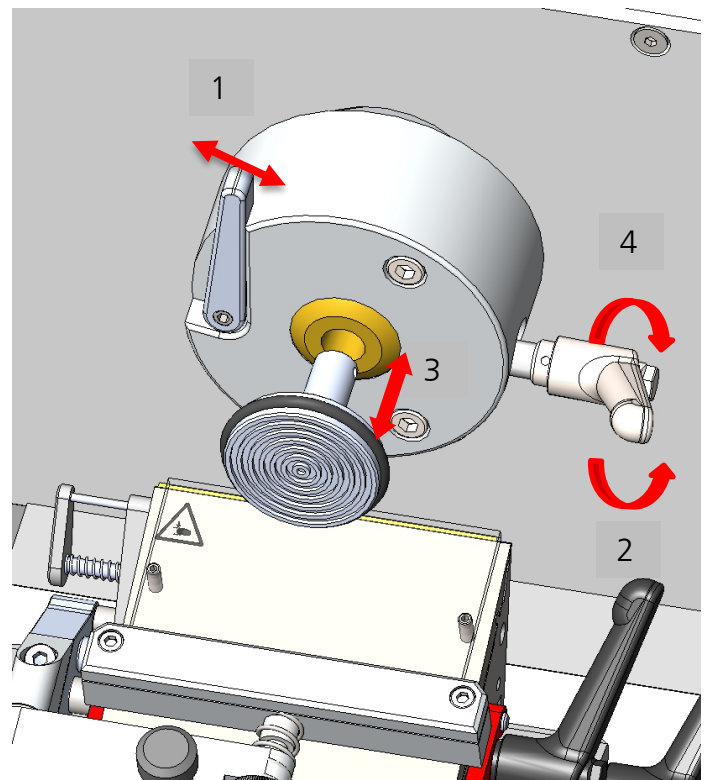

Release of object holder fixation; removal and/or insertion of object holder.



## 8.5 SPECIMEN ORIENTATION ADJUSTMENT

Turn hand wheel to its highest position and activate the hand wheel lock.

1. For a new sample orientation, loosen the fixation lever on the left side of the sample holder counterclockwise.
2. To adjust the orientation, swing the right orientation screw.

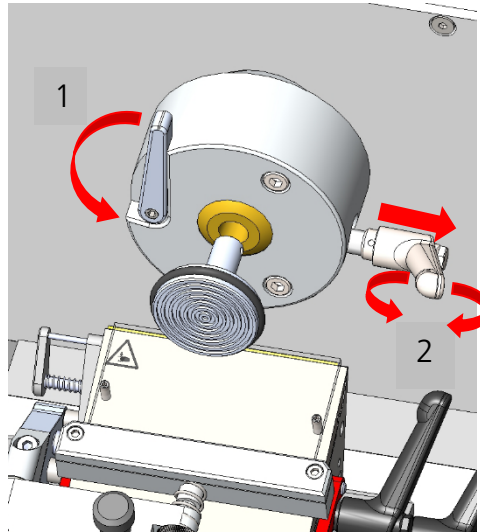

Release the sample orientation and orientation of the sample.

Fix the sample orientation by turning the fixation lever on the left side of the sample holder clockwise.

Release the handwheel lock to cut the samples.

The object orientation has a zero point notch and automatically locks the sample holder parallel to the microtome.

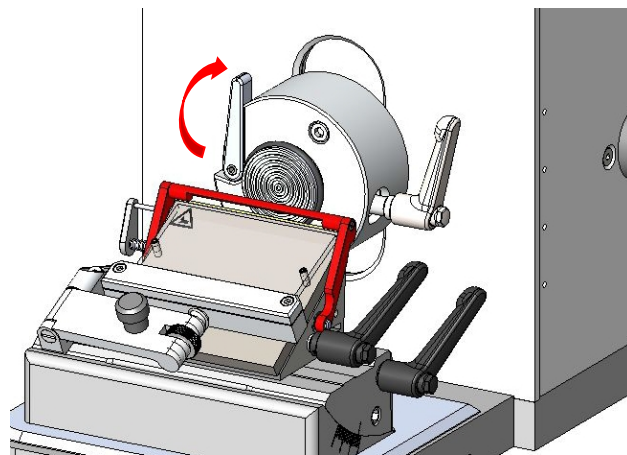

Fix the sample orientation.

## 8.6 FAST APPROACH TO SPECIMEN



## 8.7 SLOW APPROACH TO SPECIMEN



## 8.8 THICKNESS ADJUSTMENT FOR TRIMMING



## 8.9 THICKNESS ADJUSTMENT FOR CUT



## 8.10 TRIMMING OF SPECIMEN

Insert object holder.

Orientate specimen as desired.

Deactivate the hand wheel stop.

Release finger protection.

If Trim latching mode is activated, trimming function is activated and deactivated by pressing  once. Activation of trimming function is displayed as illustrated.

TUE 13:05:05	
--TRIM--	Trim: 19µm
Cha: -20 °C (-22)	QF: 0
Status:OK	0000



Activation of trimming function is displayed as illustrated above.

Turn hand wheel evenly clockwise

## 8.11 MANUAL CUTTING

Deactivate the hand wheel stop.

Release the finger protection.

Turn hand wheel evenly clockwise.

A counter clockwise movement will also result in cutting and incremental advance of the specimen.

Approach specimen either by trimming or slow approach.

Set the required section thickness. Change entries by pressing  or . The selected section thickness is indicated in the display.(e.g. 7  $\mu\text{m}$  in this example)

TUE 13:05:05	
CUT: 7 $\mu\text{m}$	Trim: 19 $\mu\text{m}$
Cha: -20 °C (-22)	QF: 0
Status:OK	0000

Turn hand wheel until some even sections have been obtained.

Clean the microtome knife or disposable blade (always away from the cutting edge) with a cold brush.

Position anti-roll plate onto the microtome knife or disposable blade and cut. If necessary readjust the height of the guide plate.

Leave hand wheel with handle at its lowest point (specimen holder underneath the microtome knife or disposable blade).

Transfer the section onto a slide.



Leave brush always in the chamber to keep it cold.

## 8.12 ANTI-ROLL PLATE

Each instrument is equipped with an anti-roll plate.

To adjust the anti-roll-plate vertically, turn the wheel on the base to the left (towards the blade) or to the right (away from the blade).

To remove the slices, swing the anti-roll-plate to the left.

For an adjustment of the anti-roll-plate (slit width), turn the screws on the two sides of the plate. A rotation of  $30^\circ$  corresponds to a height adjustment of approx.  $50\mu\text{m}$ .

The anti-roll-plate can be exchanged with a few simple steps. To do this, loosen the screws on the anti-roll-plate-base and pull the anti-roll-plate out of the guide. The new anti-roll-plate can be used simply by inserting it into the guide. Before tightening the screws, please check that the edge of the anti-roll-plate is aligned with the blade!

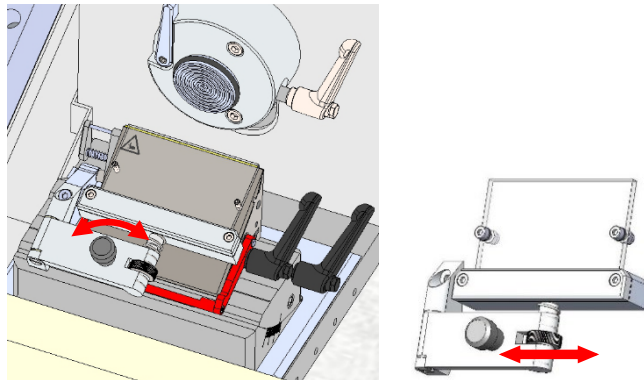

Verticale adjustment of anti-roll plate.

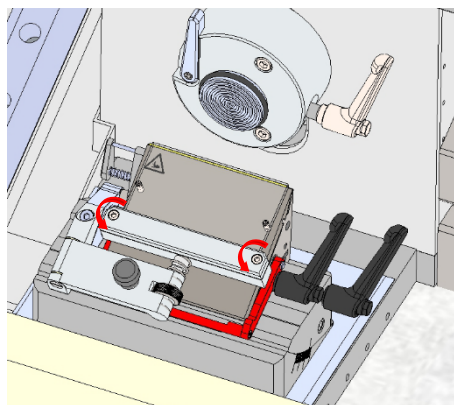

Height adjustment of anti-roll plate.

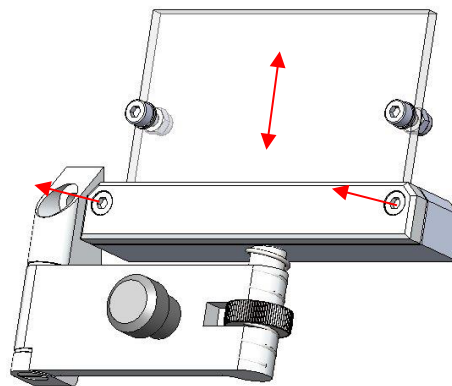

Exchange of anti-roll-plate



For height adjustment of the anti-roll-plate it is recommended to adjust the correct height during cutting.

## 8.13 TIPS AND TRICKS

It is common knowledge that the temperature of the cryostat plays an important role in the quality of the tissue sections obtained. Each type of tissue needs a different temperature as shown in the following list. The temperature ranges indicated in the table below are approximate values and may require adjustments for individual tissues.

Type of Tissue	Recommended temperature range at the knife or blade edge [°C]
----------------	---

Bone marrow	-16 to -25
Brain	-7 to -10
Breast with fat	-25 to -30
Breast without fat	-16 to -20
Cartilage	-13 to -20
Fat	-30 to -40
Heart	-20 to -25
Intestinal	-13 to -20
Kidney	-13 to -20
Larynx	-13 to -16
Lip	-10 to -20
Liver	-7 to -13
Lung	-13 to -20
Lymph-Node	-13 to -20
Lymphatic	-13 to -20
Lymphoid	-13 to -20
Muscle	-13 to -20
Nose	-13 to -20
Rectal	-13 to -20
Scrapings	-16 to -25
Skin with fat	-16 to -25
Skin without fat	-10 to -16
Spleen	-7 to -10
Testicle	-10 to -13
Tongue	-13 to -20
Uterine-	-7 to -10

■ For tissue, which has to be cut considerably below normal chamber temperature (e.g. fatty tissues) and in order to avoid cooling artefacts, an additional bench top CO<sub>2</sub> freezer is available.

Exceptionally freezing spray can be used.

## 9. OPERATION OF CRYOSTAT

### 9.1 UVC DISINFECTION

UV-C radiation at 254 nm has an intense germicidal effect. Microorganisms, such as viruses, bacteria, fungi and yeasts are effectively destroyed in the area accessible to UV light without the addition of chemicals.

The cryostat MEV + can be equipped with an UVC light source that can either request activation in defined periods (see section 7.3) or is manually activated.

The default setting for the UVC light duration and the automatic deactivation is set to 30 minutes. The timer can be set by an authorized service technician.



For safety reasons UVC light will be deactivated upon opening of the lid of the cryochamber. The UVC disinfection will be aborted and has to be activated again for surface disinfection.

The default setting for automatic deactivation is set to 30 minutes. The timer can be set by an authorized service technician.

#### 9.1.1 INSTALLATION INSTRUCTION FOR UV LAMP - CRYOSTAT

Please follow the respective steps and pay attention to the relevant instructions.

**Never** directly touch the UV lamp's glass, since this reduces its durability.

Picture 1:



Picture 2:



Picture 3:



Slide the UV lamp as shown into the glass bulb. Keep 2 cm space before the end position will be reached, this place will be needed to connect the UV Lamp with the connecting plug. (Pic. 2 & 3)

Picture 4:



Picture 5:



The connector can be plugged into two directions of polarity, a switch is excluded.

Picture 6:



Picture 7:



Once the plug is connected to the UV- Lamp, the final step can be done now and the UV-Lamp unit can clip into the retaining clips.

## 9.2 QUICK FREEZE POSITION

For convenience of the user, the cryostat MEV + is equipped with a quick freeze shelf with two positions located in the object freezing shelf. Upon activation the installed peltier element will cool down the two quick freeze position to approximately  $-55\text{ }^{\circ}\text{C}$ . The quick freeze shelf can be activated as described in section 7.2.



The default setting for automatic deactivation of the quick freeze is set to 30 minutes. The timer for automatic deactivation can be set by an authorized service technician.

## 9.3 HEAT EXTRACTOR [additional equipment]

For a more rapid freezing process with improved structural preservation of tissues and a flattened block surface, the instrument is equipped with a heat extractor.

Apply the heat extractor on top of the specimen during the freezing process.

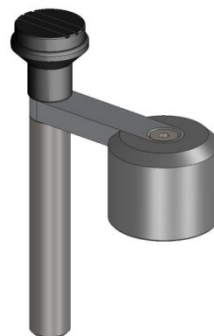

Heat extractor



Use of the heat extractor can lead to changed orientation of the specimen in the frozen block, especially in case of smaller samples. If precise orientation of the specimen is required, the freezing procedure should be performed without the heat extractor.



## 9.4 AUTOMATIC/MANUAL DEFROST

For optimum performance of the cooling unit a low thermal contact resistance at the cooling lamella is required. Upon frequent use of the instrument moisture will condensate and freeze on the surface of the cooling lamella and increase the thermal contact resistance. To avoid further build-up of the ice film, automatic defrosting cycles can be performed.

During an automatic defrost or a manual activated defrost hot gas from the cooling system is pressed through the evaporator. All ice which has built up is melted, the water drops into a heated tray below of the evaporator and from there it flows into a tray with hot tubes and evaporates inside the instrument.

The defrost will last till the system reaches a temperature of +20°C on the evaporator. The temperature inside the chamber is still below 0°C so that samples can be left on the cooling bar.



The default setting for automatic defrost is set to 00:00 o'clock (midnight) each day. For changing the settings, please refer to section 7.3.  
Always keep the front cover closed during the process.

## 9.5 SHUTDOWN AND CLEANING THE DEVICE

It is highly recommended to defrost the instrument at least every 6 months. If the instrument is used regularly in warm tropical climate a more frequent complete defrost might be necessary. The unit should be defrost for a minimum period of 48 h, better over the weekend.

Turn hand wheel to its highest position and activate the hand wheel stop.

Remove samples and tools from the cryochamber.

Switch off the instrument. Be sure to open the front window and leave it open until it is switched back on.

Before restarting, the microtome and the cooling chamber must be completely dry in order to avoid a decision.

Switch on the instrument.



Before starting a complete defrost of the instrument, assure that all samples have been removed from the cryochamber.

Before switching on the instrument ensure that the instrument is completely dry, otherwise ice built up can damage mechanical parts.

## 9.6 EMPTYING THE CONDENSATE BOTTLE

The unit is equipped with a condensate bottle for defrosting water. The filling level of the collecting container is checked with a fill level sensor. As soon as "full container" is displayed, the collecting container must be emptied in order to avoid overfilling.



The contents of the condensate bottle should be disposed according to laboratory regulations.



To reduce the risk of contamination and infection, after emptying, it is recommended to fill a disinfectant concentrate into the condensate bottle.

## 10. CLEANING AND MAINTENANCE

### 10.1 CLEANING

The recommended frequency of cleaning of the cryostat chamber depends on how frequently the instrument is used.



Wear protective clothing and disposable gloves according to Good Laboratory Practices.

Please take note of the safety aspects of the instrument.

Do not use acetone or xylene for cleaning the unit. Only use alcoholic media.

Never spray or use cleaning medium directly onto the touch panels.

### 10.2 DISINFECTION

Spray disinfection with alcohol-based disinfectants is applicable without removing the microtome from the cryochamber. When disinfecting the instrument, take appropriate protective measures (gloves, mask, protective clothing, etc.).



Wear protective clothing and disposable gloves according to Good Laboratory Practices.

When using detergents and disinfectants please comply with the safety precautions of the disinfectant manufacturer!

The integrated anti-roll plate of the blade holder can be cleaned with alcohol.

Dispose of waste liquid according to the waste disposal regulations!

Do not turn the instrument on before the cryochamber and the microtome are completely dry otherwise ice built up can damage mechanical parts.

All components removed from the cryostat must be carefully dried before returning them to the cryochamber!

### 10.3 RECOMMENDED MAINTENANCE AND SERVICE SCHEDULE

- Daily** Remove frozen section waste from the cryostat chamber after every day of usage.  
Disinfection if necessary.
- Weekly** Cleaning of blade holder (see section 10.3).  
Cleaning of window.
- Monthly** Check of temperature sensor in cryochamber.  
Cleaning of cryostat ventilation (see section 10.4).
- Yearly** Complete Service (performed by authorized Slee service technician)
- check of all functions
  - complete defrost
  - removing of microtome
  - oiling of movable parts
  - check of cooling system
  - check of driving system
  - complete disinfection / cleaning / drying

## 10.4 CLEANING OF DISPOSABLE BLADE HOLDER

Turn the handwheel to the highest position and operate the handwheel lock.

Loosen the blade by turning the lever counterclockwise.

Use the blade ejector to remove the blade.

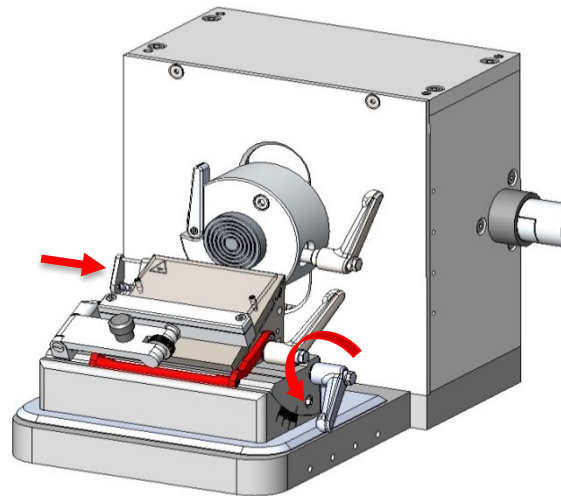

Pull out the lever and release the upper blade holder.

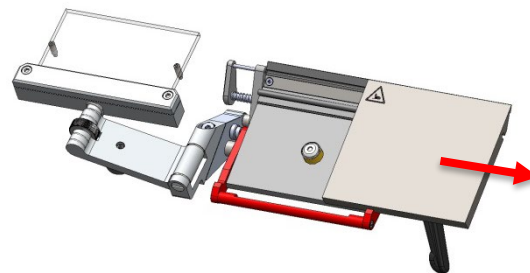

After removing the blade, pull out the lever, remove the pressure plate and clean the blade holder with a brush or cloth.

Cleaning of disposable blade holder.

Reassemble the pressure plate and the lever and loosen the locking device for cutting.

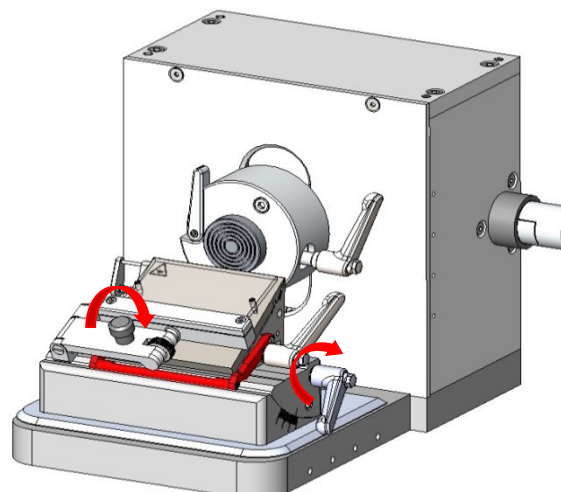

Assemble the blade holder.

## 10.5 CLEANING OF CRYOSTAT VENTILATION

During usage of the instrument dust will deposit on the ventilation of the cooling unit. This can negatively affect the cooling performance of the instrument.

A cleaning of the cryostat ventilation is recommended monthly.

We suggest using a vacuum cleaner and a brush for cleaning.

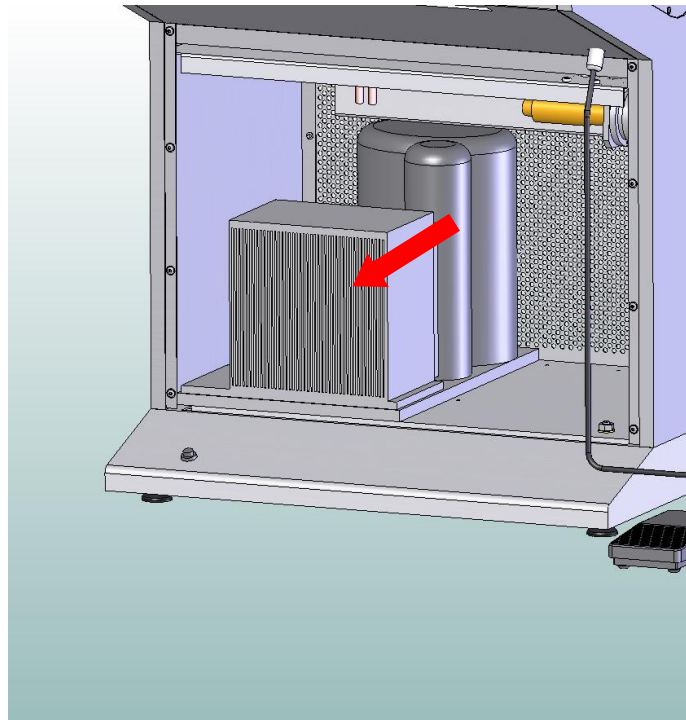

## 11. SERVICE

Internal components should only be serviced by technicians authorized by SLEE medical GmbH.

If technical service or spare parts are necessary, please contact your local SLEE medical GmbH distributor. Please have the following information available:

- Complete contact details
- Type of instrument and serial number
- Place of instrument and name of user
- Purpose of service call
- Delivery date of the unit

If it is necessary to return the instrument, it must be cleaned and disinfected before delivery. It must be returned in its original packing.

If the instrument or parts thereof are sent back in a dirty or non-disinfected condition, SLEE medical GmbH reserves the right to return the parts to the debit of the customer.

## 12. OPTIONAL ACCESSORIES

### **Standard Knife Holder**

#10156010

### **Disposable Blade Holder (low profile)**

#10157005

### **Disposable Blade Holder (high profile)**

#10158005

### **Debris extraction system**

#10167100

### **Heat extractor block**

# 31000253

### **Object holder (Ø 22 mm)**

#30000002

### **Object holder (Ø 35 mm)**

#30000000

### **Object holder (Ø 50 mm)**

#30000003

### **Cork plate (100 pcs.; Ø 20 mm)**

#30001001

### **CryoGlue embedding medium (4x 125 ml)**

#30001100

### ***clear-cut* brush**

#30001030

### **Anti-roll plate (disposable blade holder)**

#32001050

### **Anti-roll plate (standard knife holder)**

#32001049

### **Disposable blade (low profile; 50 pcs.)**

#28407000

### **Disposable blade (high profile; 50 pcs.)**

#28408000

### **Disposable blade (low profile; 50 pcs.), Plasma LPH, for hard specimen**

#28407004

### **Disposable blade (low profile; 50 pcs.), Plasma LPS, for soft specimen**

#28407005

### **Disposable blade (high profile; 50 pcs.), Plasma HPS, for soft specimen**

#28407007

### **13. WARRANTY**

SLEE medical GmbH guarantees that the product delivered has been subjected to a comprehensive quality control procedure, and that the product is faultless and complies with all technical specifications and / or agreed characteristics warranted.

SLEE medical GmbH guarantees that the device is manufactured under an ISO 9001:2015 and ISO 13485:2016 quality management system.

Unauthorized modification or repair by third party persons will void the warranty.

Only original SLEE medical GmbH spare parts must be used.

Guarantee claims can be put forward only if the device is used according to this manual and for the purpose described.

Mistakes and errors which occur because of improper use cannot be accepted.

### **14. DISPOSAL**

The device or parts of the device must be disposed of according to existing local applicable regulations.



## Notes

## Notes

## Notes



SLEE medical GmbH · Am Neuberg 14  
55268 Nieder-Olm · Germany  
[www.slee.de](http://www.slee.de)

T: +49 (0) 6136 76997-0  
E: [mail@slee.de](mailto:mail@slee.de)



[www.slee.de](http://www.slee.de)



[YouTube](#)



[LinkedIn](#)



[Instagram](#)