

— NOWY STYL GROUP® —

-forum-  
seating®

---

# OSCAR

---

*Designed by: Stanisław Charaziak*



AUDITORIA



CULTURAL  
CENTRES



# ART IN GOOD SHAPE

*A harmonious and timeless shape, simple and classic design, refined details: these are the characteristic features of Oscar. This exclusive armchair designed by Charaziak Design Studio is intended for use in prestigious facilities, such as theatres or operas. Its aesthetically pleasing appearance has been perfectly combined with great functionality and acoustic properties to increase the user's comfort.*



PROJECT:

## STANISŁAW CHARAZIAK

*Charaziak is a graduate from Academy of Fine Arts in Warsaw, the Faculty of Industrial Design. Since 1996 he has been dealing solely with industrial design. Charaziak defines his projects as „ergonomics and user comfort wrapped in an exceptional style.” So far he has designed more than 300 chairs, several cabinet furniture systems, cinema seats and auditorium systems, all of which have been produced. He only designs products to be manufactured on a mass scale. For Nowy Styl Group he has created the auditorium systems Oscar, Tiago and Vision, as well as a wooden furniture collection.*

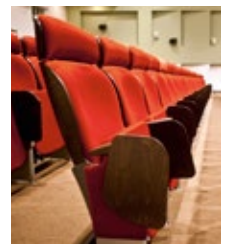

The Oscar armchair has a stable steel frame. The specially designed shape of this model ensures convenient spine support, even during a play or a concert that lasts a few hours. The backrest structure is made of ergonomically contoured plywood. It is covered with an upholstered cushion filled with polyurethane foam. The armchair seat is made of the same material. The materials used in Oscar provide users with excellent comfort and are highly durable at the same time.

The armrests, made of solid wood or upholstered, are available in three different lengths. In combination with the backrest cover made of multilayer plywood, they highlight the unique character of the product. The wood is available in many natural shades. Thanks to its refined details, the

armchair is an ideal choice for interiors in which aesthetics is top priority.

The wooden acoustic panel fixed to the underside of the seat has a positive influence on the acoustic properties of an interior. What's more, the armchair is equipped with a quiet folding mechanism.

Its classic design and high functionality make Oscar a universal armchair. Thanks to the wide range of available finishes and configuration possibilities, the armchair can be adjusted to every interior. Oscar is a perfect solution, not only for concert halls, where acoustic properties are highly appreciated, but also for theatres, cinemas and representative lecture halls.



Oscar with a desktop

Oscar with a headrest

Slim  
DIMENSIONS\*:

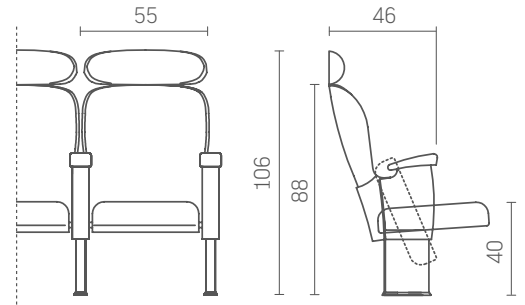
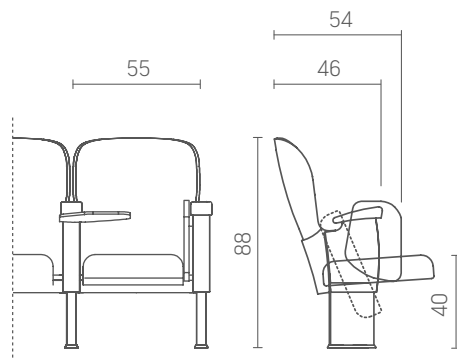

Mid  
DIMENSIONS\*:

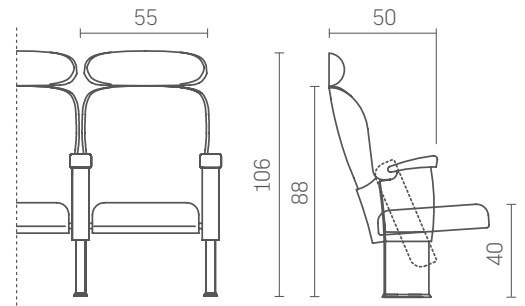
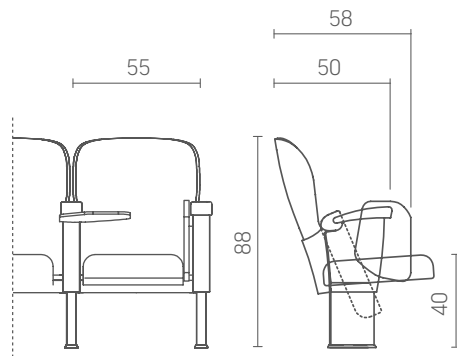

Comfort  
DIMENSIONS\*:

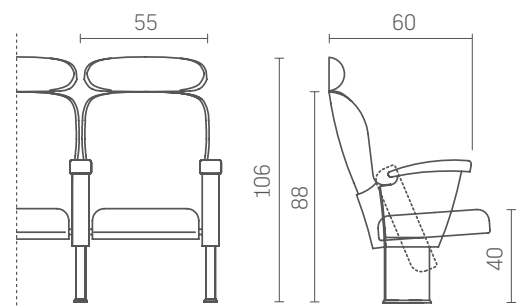
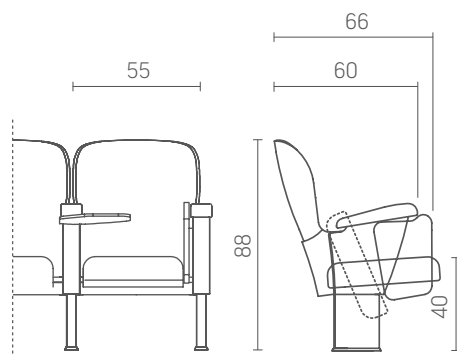

\* Particular dimensions can be individually adjusted to a given project. All dimensions are in centimetres.

## Oscar Levi (Slim/Mid/Comfort)



### DIMENSIONS\*:

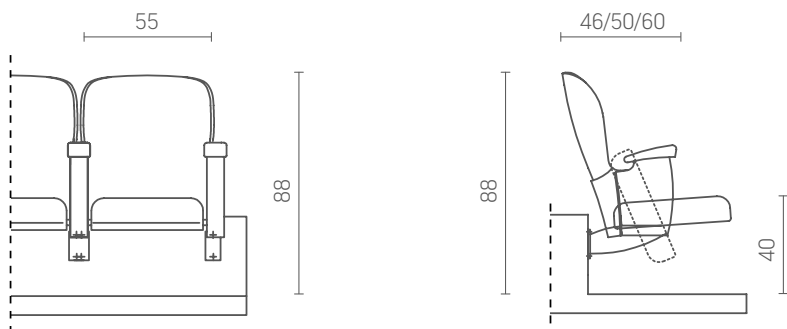

\* Particular dimensions can be individually adjusted to a given project.  
All dimensions are in centimetres.

### CHARACTERISTIC FEATURES AND AVAILABLE OPTIONS:

- Oscar has the GS certificate, which confirms that the product meets the European safety and quality standards.
- The armchair is available in three widths: slim, mid and comfort.
- The armchair backrest can be made of varnished plywood or it can be fully upholstered (in the latter case, it is advisable to apply a special plastic cover on its lower part).
- A desktop facilitates notes taking, and the convenient folding system makes it easier for users to move between rows.
- The armchair can be additionally equipped with an upholstered headrest, which gives the interior a unique character.
- The row and seat numbers can be fixed to the armchair or embroidered on its backrest, seat or sides.
- It is also possible to embroider the logo of a venue or a sponsor's name on the armchair.
- Some armchairs can be fixed as cantilever models, which means they can be removed easily. It is exceptionally useful and allows for different arrangements of the hall (e.g. when there is a need to make some room for camera operators).





**CERTIFIED PRODUCTION:**

We manufacture products at a global level. Our chairs are characterised by top quality and the highest durability. In all of our production plants we have implemented the best quality management system:

**ISO 9001:2000.** At the same time, we take care of the natural environment. We use the environmental management systems created according to the **ISO 14001** standard in the majority of our factories. This enables

us to minimise our impact on the natural environment and confirms that our products contain no heavy metals.

**ASSEMBLY OPTIONS:**

Floor type:



Flat

Inclined

Stairs

Armchair arrangement:



In a straight line

Assembly types:

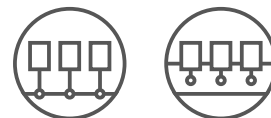

TYPE C  
to the floor

TYPE A  
to the step riser

[www.ForumSeating.com](http://www.ForumSeating.com)  
[www.NowyStylGroup.com](http://www.NowyStylGroup.com)

