

SIZE IN MILLIMETRS

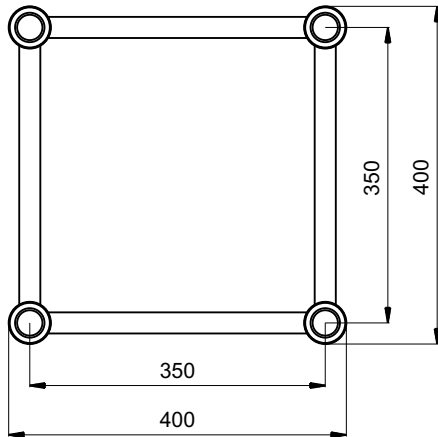

SIZE IN INCHES

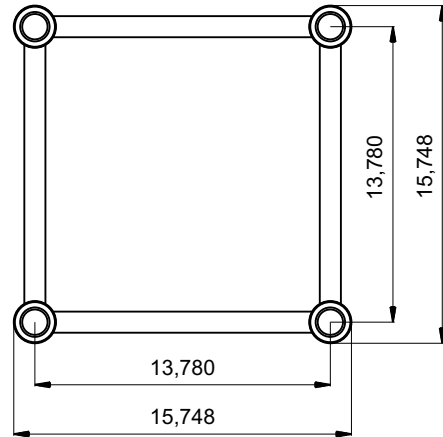

SPECIFICATIONS HT44

TUBES	50x3mm (2 x 0.12inch)
BRACES	25x3mm (1 x 0.12inch)
ALLOY	EN-AW 6082 T6



STRAIGHT SEGMENT LENGTHS HT44

CODE	LENGTH		WEIGHT	
HT44-50	0.5m	1.64ft	5.6kg	12.24lbs
HT44-100	1m	3.28ft	9.7kg	21.34lbs
HT44-150	1.5m	4.92ft	13.4kg	29.50lbs
HT44-200	2m	6.56ft	16.9kg	37.33lbs
HT44-250	2.5m	8.20ft	20.6kg	45.38lbs
HT44-300	3m	9.84ft	24.6kg	54.22lbs
HT44-350	3.5m	11.48ft	28.1kg	61.96lbs
HT44-400	4m	13.12ft	31.9kg	70.34lbs
HT44-450	4.5m	14.76ft	35.4kg	78.06lbs
HT44-500	5m	16.40ft	39.4kg	86.85lbs

LOADING TABLES HT44

	2m	4m	6m	8m	10m	12m	14m	16m
Distrib. Load [kg/m]	2327	901	417	243	162	112	82	61
Deflection [mm]	1.3	8	18.9	35.4	58.8	86.5	119.8	158.7
Point load [kg]	3267	1803	1252	971	811	675	573	477
Deflection [mm]	1.4	6.4	15.2	28.5	47.6	70.5	98.3	127.8
	6.56ft	13.12ft	19.68ft	26.24ft	32.81ft	37.37ft	45.93ft	52.49ft
Distrib. Load [lb/ft]	1563.9	605.5	280.2	163.3	108.9	75.3	55.1	41
Deflection [inch]	0.1	0.3	0.7	1.4	2.3	3.4	4.7	6.2
Point load [lb]	7203.7	3975.6	2760.7	2141.1	1788.3	1488.4	1263.5	1051.8
Deflection [inch]	0.1	0.3	0.6	1.1	1.9	2.8	3.9	5