

# Manual

## Piab Bulk Bag Unloader

### FIBC Emptying Station with Forklift Loading



Original Instructions, Rev 00, 2026-02-12

---

## Table of Contents

---

|       |   |    |
|-------|---|----|
| 1     | Technical data .....                                  | 3  |
| 2     | Safety .....  | 4  |
| 2.1   | Symbol .....  | 4  |
| 2.2   | Operating instructions .....                          | 5  |
| 2.3   | Personal .....  | 6  |
| 2.4   | Dangers when handling the Piab system .....           | 6  |
| 2.5   | Hazard analysis.....                                  | 7  |
| 2.6   | Intended use.....                                     | 7  |
| 2.7   | Disclaimer .....                                      | 8  |
| 2.8   | Tools .....   | 8  |
| 3     | Transport, assembly, assembly site .....              | 9  |
| 3.1   | Delivery and in-house transport.....                  | 9  |
| 3.2   | Instructions for decommissioning and recycling.....   | 9  |
| 3.3   | Installation of the Piab system.....                  | 10 |
| 3.4   | Storage.....  | 12 |
| 3.5   | Electrical Requirement .....                          | 12 |
| 3.6   | Commissioning of the Piab system .....                | 13 |
| 4     | Function – Operation .....                            | 14 |
| 4.1   | Structure of some possible systems.....               | 15 |
| 4.2   | Component Description .....                           | 18 |
| 4.2.1 | Adjustable upper frame .....                          | 18 |
| 4.2.2 | FIBC lifting beam, traverse.....                      | 19 |
| 4.2.3 | Spectacle closure Ø200/Ø300 – DS2/DS3.....            | 21 |
| 4.2.4 | Inflating cuff 2.0 Ø200/Ø300 - DI2/DI3 .....          | 23 |
| 4.2.5 | Feed hopper - DF.....                                 | 25 |
| 4.2.6 | Vibration motor - V .....                             | 26 |
| 5     | Maintenance and repair .....                          | 27 |
| 5.1   | General information.....                              | 27 |
| 5.2   | Maintenance.....                                      | 28 |
| 5.3   | Inspection of Pneumatics and Electrical Systems ..... | 29 |
| 6     | Spareparts.....                                       | 30 |

# 1 Technical data

## FIBC DATA

- Size (B x T x H): Minimum 950 x 950 x 1100-2100 mm  
Maximum 1050 x 1050 x 1100-2100mm
- Loops: 4 loops, length 250 mm
- Outlet spout: Diameter: Ø300/Ø450mm  
Length: 500 mm
- Weight per FIBC: max. 1250/1600 kg
- Insertion: by forklift

## MATERIALS

- Product contact: Stainless steel 1.4301
- Not in contact  
with the product: Mild steel 1.0038
- Purchased parts: partly deviating from proven  
Suppliers standard, non-corrosive,  
or coated (also crane)

## INSTALLATION CONDITIONS

- Environment: Indoor installation +5°C to +35°C
- Humidity: max. 70%

## INTERFACE

- Electric: Electricity: Feed-in point in the control unit.
- Process: Flange under FIBC docking device
- Mechanics: The foundation plate der FIBC-Station

## 2 Safety

### 2.1 Symbol

You will find the adjacent symbol in the BWA wherever it is not observed.

- danger to the life and limb of persons.
- Damage to the device may occur.



The adjacent symbol can be found in the BWA wherever there is danger from suspended loads.



You will find the adjacent symbol in the BWA wherever there is danger from objects that can tip over.



You will find the adjacent symbol in the BWA wherever there is a danger from moving components.



The adjacent symbol can be found in the BWA wherever there is a risk of moving into running machine components.



You will find the adjacent symbol in the BWA wherever there is danger from electrical components.



The symbol on the right indicates that the electrical conductivity of the system must be ensured (earthing).

## 2.2 Operating instructions



The prerequisite for avoiding danger to people and damage to the Piab system is knowledge of and compliance with the instructions in this operating manual.

This instruction manual contains the most important information for operating the Piab system safely. Request additional information if necessary.

All persons who work on the Piab system must know and observe this operating manual.

Keep this instruction manual at all times at the place of use of the Piab system so that it can be viewed by the operating personnel at any time.

In addition to the operating instructions, the safety regulations, rules and regulations applicable to the place of use for accident prevention and environmental protection must be observed.

The operator is responsible for integrating the Piab system into higher-level processes and operating instructions tailored to the application.

## 2.3 Personal



The operating personnel at the Piab system must be aware of and observe the following regulations:

- The basic and necessary regulations on occupational safety, accident prevention, and environmental protection
- The provisions on occupational safety, accident prevention, and environmental protection for the bulk material to be processed, in particular on "personal protective equipment" to be used
- The basic safety instructions in this user manual

The safety and warning instructions in this instruction manual are applicable to your work.

The responsibilities of the operating personnel must be clearly defined in advance for the:

- Assembly
- Commissioning
- Service
- Maintenance and repair

All repair and maintenance work must only be carried out by qualified personnel

### Personal protective equipment

- Gloves
- Head protection
- Shoes with safety toe cap

## 2.4 Dangers when handling the Piab system

The Piab system is built according to the current state of the art and the recognized safety regulations. Transport, assembly, commissioning, operation and maintenance must be carried out by qualified specialists.

If there are special hazards due to the intended use, the place of use, a combination with other machines, etc., additional safety instructions and measures are necessary, which must be determined by the system operator!

Nevertheless, the Piab system can pose a risk to the user or to tangible assets, in particular if:

- the Piab system is not used for its intended purpose
- the Piab system is operated without safety equipment
- the safety instructions are not observed

Cleaning work or repairs can be carried out while the Piab system is running.

## 2.5 Hazard analysis



The removal of protective devices and covers from rotating parts, such as worm shafts, ventilation wheels, rotors, are not permitted, as they can lead to serious injury to body parts.

The operation of the Piab system with open observation and maintenance windows is not permitted, as it can lead to serious injuries due to rotating machine parts inside the machine or system.

The drives required for the function of the Piab system are, depending on the design, operated on the industrial, electrical power grid. This dangerous tension can lead to serious damage to people and objects if careless. The cause of damage can be, among other things:

- unauthorized removal of covers or protective equipment
- improper use of components or tools
- improper operation
- inadequate maintenance and servicing
- non-compliance with the BA or corresponding operating instructions

The operator must ensure that the operating and maintenance personnel are instructed before working on and with the Piab system!

## 2.6 Intended use



The Piab system is built exclusively for operating conditions as described in the order documents (intended use).

Compliance with the permissible process parameters must be ensured by the system operator.

Any other use or use beyond this is considered not to be in accordance with its intended purpose. Piab AB is not liable for damage caused by improper use.

The design of the IB system was carried out according to the specifications of the client / operator. Piab AB assumes that this information is correct.

The intended use also includes:

- observing the operating instructions
- full compliance with the requirements required in the hazard analysis measurement
- compliance with inspection and maintenance regulations.

## **2.7 Disclaimer**

Failure to comply with the technical suitability limits and the safety instructions releases Piab AB from warranty and liability for consequential damages resulting from this. The same applies to defects caused by failure to carry out the recommended inspections in a timely manner or improperly.

## **2.8 Tools**

For explosive areas, no spark-causing or magnetic hand tools made of certain alloys may be used.

Only these tools guarantee safety when working with highly flammable materials in an explosive environment.

## 3 Transport, assembly, assembly site

### 3.1 Delivery and in-house transport



#### Safety

Unloading and internal transport may only be carried out by qualified personnel. Note the weight of the packages/components and their center of gravity

Use only suitable industrial trucks, crane systems and slings that are appropriate to their weight and dimensions

Suitable anchorage points must be used on the system

The floors, ceilings, loading ramps, lifts, steel structures, etc. contaminated by the internal transport must be checked for the corresponding load caused by the transport and declared safe.

#### Damage

The Piab system was handed over to the forwarder in perfect condition. Please check the Piab system immediately upon delivery for completeness and transport damage. Detected damage must be noted on the delivery documents and thus reported to the carrier.

#### Transport of the Piab system by forklift

To lift the entire Piab facility, make sure

- that there is no material in the system components,
- that only suitable lifting equipment is used for this purpose.

The temperature should not fall below 5°C and should not exceed 40°C. In the event of non-compliance with these temperature limits, Piab AB shall be released from warranty and liability for compensation for consequential damages resulting from this. If the system is nevertheless transported at very low/high temperatures, it must be temporarily stored at the prescribed temperatures 48 hours before commissioning.

### 3.2 Instructions for decommissioning and recycling

Components that are no longer needed must not be disposed of in household waste. Please dispose of the individual components in accordance with the applicable national disposal regulations!

### 3.3 Installation of the Piab system



#### Safety

Before installation, the installation site must be checked for suitable stability and load-bearing capacity. If necessary, a static proof of the load-bearing capacity of the installation site must be provided by the client/operator.

- Use only suitable hoists for the installation of the Piab system, attach the hoists only to suitable anchor points
- Observe the safety regulations applicable to the area
- No one may be in the danger zone when lifting the system
- Only one person is allowed to give agreed signals to the crane operator
- Coordinate your work with other groups working in your area to avoid mutual exposure

# Safety through coordination!



## Setting up the Piab system

The Piab system is to be set up according to the attached installation drawings. The system components are completely pre-assembled. Depending on transport, sub-systems can also be delivered. These must then be assembled according to the assembly documents supplied. When assembling several system components to form a complete system, care must be taken to ensure that the system components/units are joined together without stress.

***System components must be firmly anchored to the ground if they are are planned.***

Depending on the design, the Piab system must be secured against tipping during operation with the enclosed screws or the heavy-duty anchors described in the annex.

**The operation of an unpaved system is not permitted.**



***For fastening, Piab load anchors from the manufacturer Fischer***

***Typ 1: Anchor bolts FAZII M20***

***Typ 2: Highbond- Anchor rod FHB II-A L M 20 with corresponding Mörtelpatrone FHB II-PF M20***

## Electrical Fittings



The electrical connection may only be carried out by qualified electricians! The network data must be compared with the connection values of the drive type plates for conformity. Care must be taken to ensure that there is a sufficient supply of cooling to the drives.

In the case of explosion-proof systems, the electrical conductivity (earthing) of all components must be ensured at all times. The connection to the building earthing system must be established and proven on site before commissioning.

When working in explosion-proof areas, it is important to ensure that the tools used have an approval for the respective requirement.

**The system must be connected to a local equipotential bonding system become!**

### **3.4 Storage**

The machine must be stored in the original packaging in an upright position in a place that is protected from the weather. The storage period of 12 months should not be exceeded after the delivery of the machine.

The ambient conditions (inside, temperature 5°C to 40°C) must be observed. In the event of non-compliance with these temperature limits, Piab AB shall be released from warranty and liability for compensation for consequential damages resulting from this.

### **3.5 Electrical Requirement**

The powder screening machine is designed for direct connection to a primary AC source of the system power grid. The electrical connection must be carried out by a qualified electrician.

All equipment and the operator must be grounded when working on the machine to avoid static charge.

### 3.6 Commissioning of the Piab system

Commissioning requires experience and expertise! You should therefore commission the company Piab Additive GmbH to carry out the commissioning. We assume no liability for damage caused by improper commissioning by other personnel!

Commissioning may only be carried out by qualified personnel! Qualified specialists are people who can identify and avoid hazards due to their specialist training in mechanics and electrical engineering, experience and instruction. When commissioning, observe the legal accident prevention regulations applicable to this system and the operator's factory regulations (safety regulations, etc.).

All bearings are provided with the necessary amount of oil or grease at the factory and do not need to be opened and filled for commissioning.

Before starting the machine, perform a functional test without material.

Only put the machine into operation if all safety devices and safety-related monitoring devices are in place and functional!

Therefore, check on the machine beforehand whether:

- it is set up and connected as described,
- all foreign objects on and in the machine have been removed,
- all security and monitoring equipment is in place and functional



## 4 Function – Operation



The emptying station is built for emptying FIBC's.

The system consists of a frame with adjustable support surface.

For the emptying of FIBC's, a spectacle closure 300 is used and designed for FIBC's with an outlet hose of Ø350 to Ø400 mm and a length of 500 mm.

The process of use is described below:

1. The FIBC is picked up with the FIBC lifting beam and brought into the system with a fork lift. (Fig.4.1.2)
2. Before the FIBC is pulled up, it is important to make sure that it is correctly inserted into the loop mounts of the lifting beam. Staying under the FIBC is forbidden.
3. How to bring the FIBC in and the different docking devices see below.
4. Check the tight fit of the FIBC outlet hose and improve if it is necessary.
5. **The FIBC can now be opened for emptying. When the tying ribbon is opened, the outlet hose is still contracted and wrinkles that negatively affect the product flow.**
6. To stretch the outlet hose, the discharge nozzle can be lowered together with the stretching device. Fig.4.1.6. To do this, the operator must leave the safety area. First of all, the light grid/safety area must be acknowledged via the control panel in order to then activate the raising or lowering of the stretching unit. The FIBC emptying station can then be released.
7. At the same time, the fulling device can support the discharge of the material. The fulling function can be set to OFF or automatic via the control panel. In automatic mode, the walkers are automatically activated in the event of a shortage of material (level detector). When walking, the two fulling plates diagonally opposite each other are always activated. (Fig.4.1.3)
8. With the precision dosing device, the product is now dosed for further processing.
9. If a FIBC is emptied and the level detector is no longer occupied, the operator receives an indication via the blue indicator light and the control system that the FIBC can be changed.
10. The process starts again at Pos.2.

## 4.1 Structure of some possible systems

Example for a fork lift loading with simple lifting beam 1600kg, FIBC height 1800, Inflating cuff Ø300 and imbalance motor.

Piab code: BBU.F16.TF1.FA.2.DI3.V

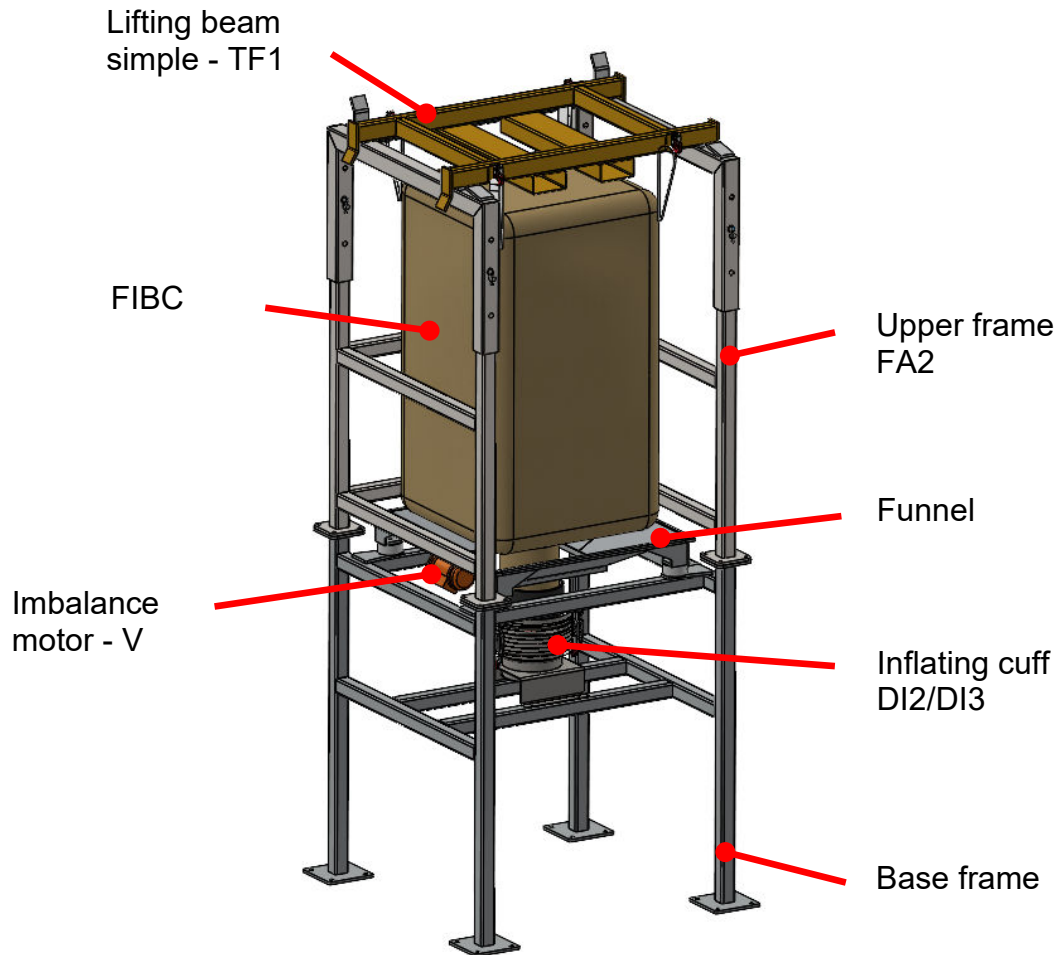

Fig.4.1.1



Images may differ slightly from reality.

Example for a fork lift loading with simple lifting beam 1250kg, FIBC height 1500, feed hopper.

Piab code: BBU.F12.TF1.FA.1.DF.X

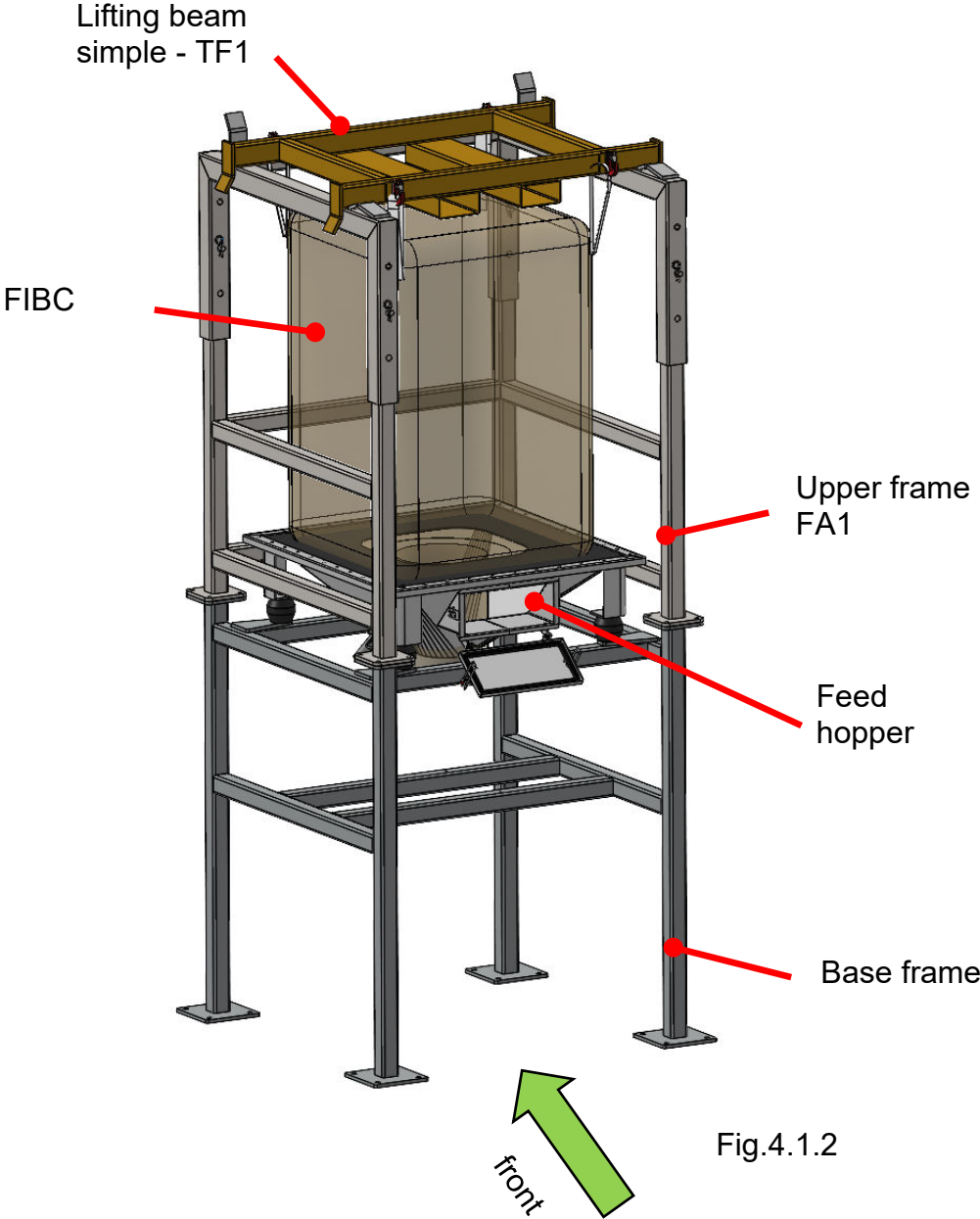
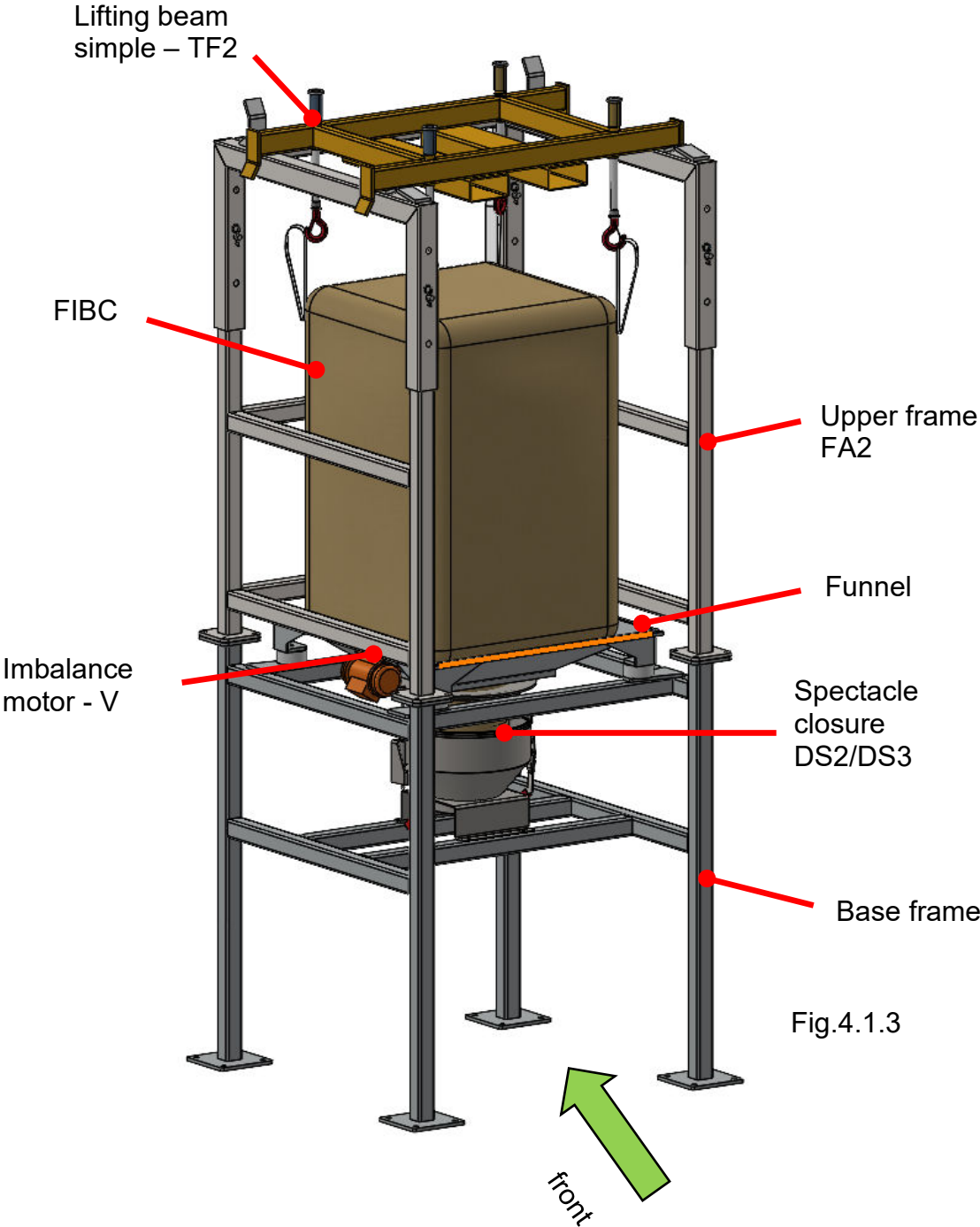

Fig.4.1.2

For very short outlet hoses, the best system!

Example for a fork lift loading with simple lifting beam 1250kg, FIBC height 1500, feed hopper.

Piab code: BBU.F12.TF2.FA.2.DS3.V



## 4.2 Component Description

### 4.2.1 Adjustable upper frame

One frame, is used for 3 types of FIBC sizes. To adjust the frame to your FIBC, use a forklift to lift up the frame and take out the 4 bolts.

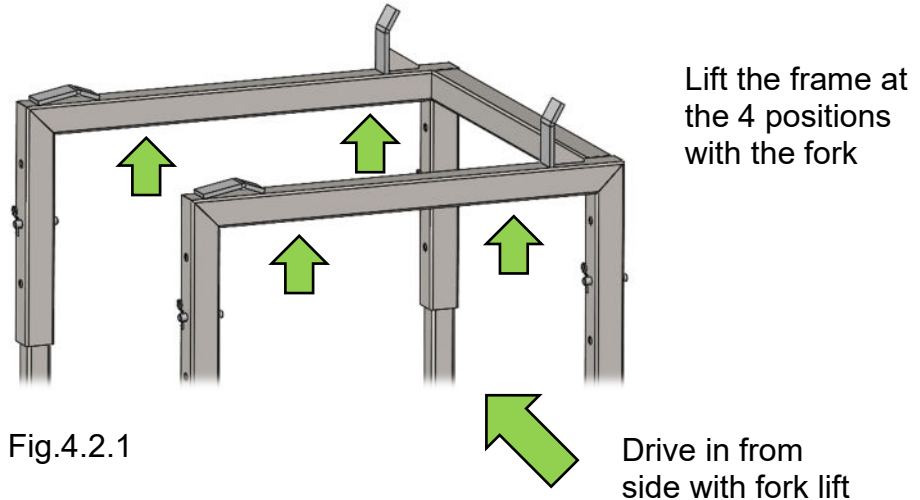

Fig.4.2.1

All drawings are with the positioning bolt in the middle of the three holes. The frame is adjustable by 200mm up and 200mm down of the middle position.

The frame is used for 3 types of

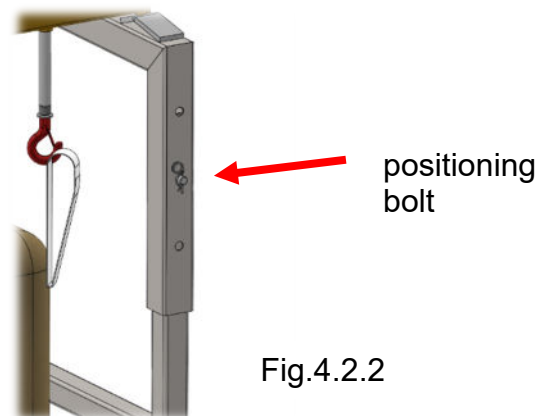

Fig.4.2.2

Locking spring

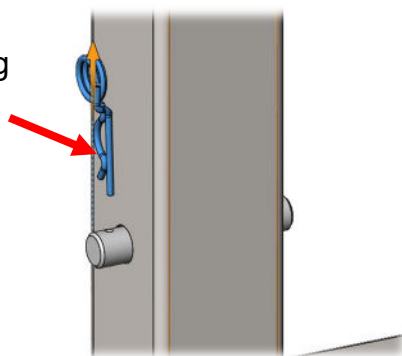

Fig.4.2.3

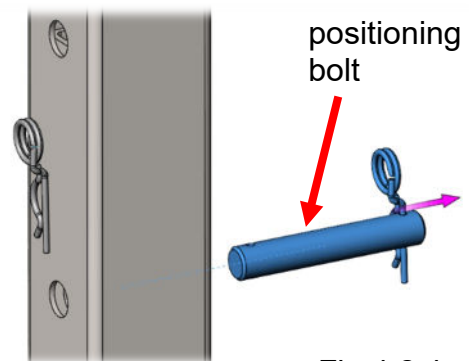

Fig.4.2.4

## 4.2.2 FIBC lifting beam, traverse

### The process of use is described below:

The FIBC is picked up from the pallet with a customer forklift. A loop is hooked into each hook, and with the forklift into the system. Before the FIBC lifts up, it is important to make sure that it is correctly inserted into the loop mounts of the lifting beam. It is forbidden to stay under the suspended FIBC. The safety tab must close and the loop must be completely in the hook.



**Be careful when pulling the loop into the hook! Risk of crushing!**



### Stretching the FIBC by the loops with spring tension - TF2

The FIBC will be hang up with the loops into the hooks of the beam. The weight of the FIBC set the springs under pressure. When the bag will get empty after time, the spring torsion lift the bag up to guaranty a better emptying of the FIBC.

Traverse TF2 for 1250 or 1600kg

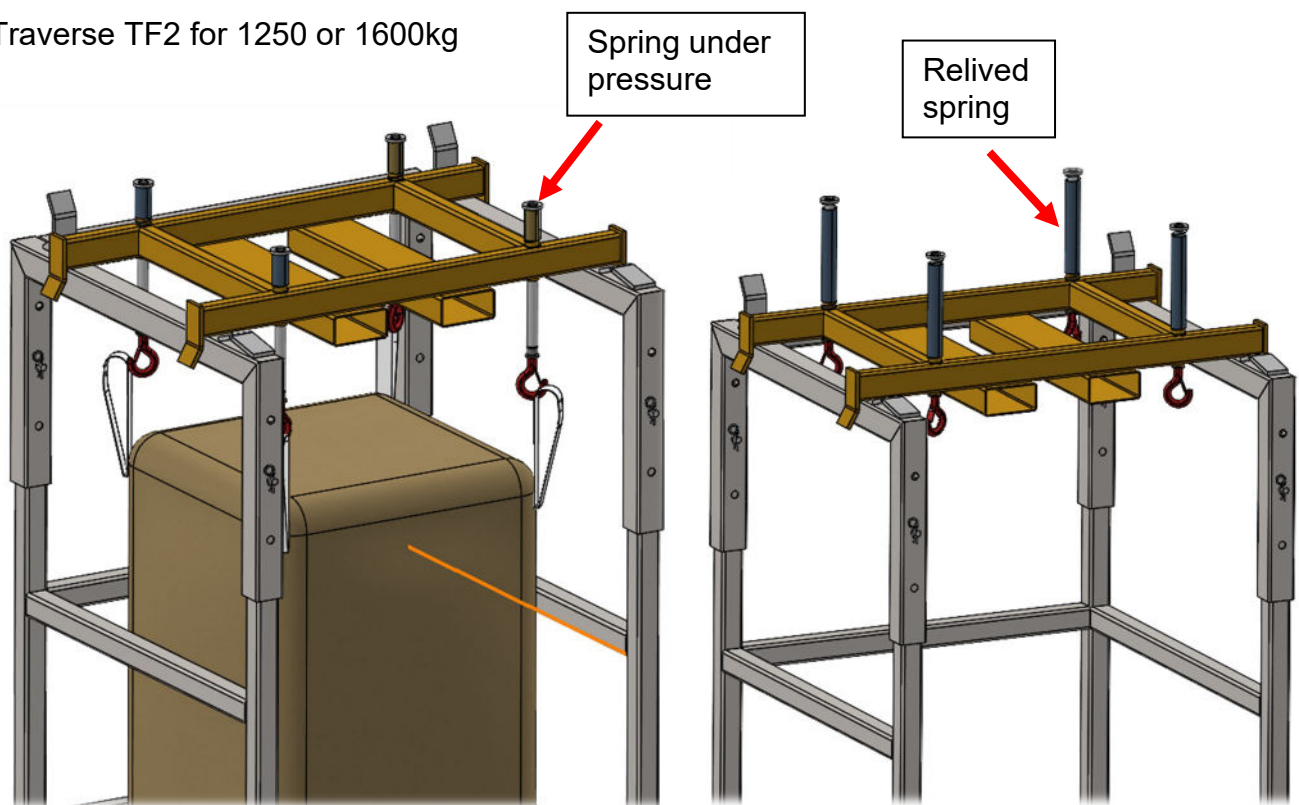

Fig.4.2.5

Fig.4.2.6

The lifting beams, traveses are built for FIBC with a size of between 900x900mm to 1000x1000mm.

**FIBC for forklift simple beam - TF1**

Traverse TF1 for 1250 or 1600kg

The FIBC will be hang up with the loops into the hooks of the beam.

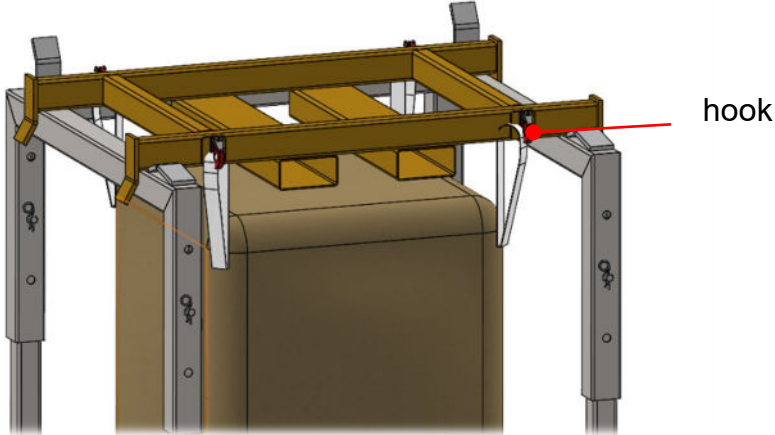

Fig.4.2.7

The travers of both solutions are the same to bring into the Station.  
The guide angle's help to find the right position of the beam.

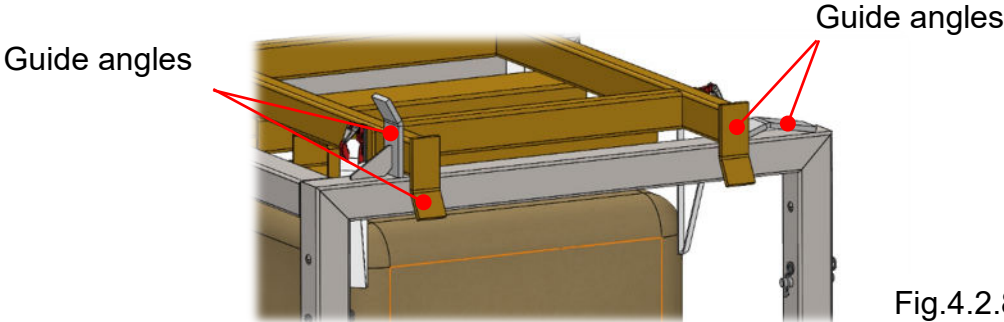

Fig.4.2.8

### 4.2.3 Spectacle closure Ø200/Ø300 – DS2/DS3



FIBC docking lid - closed

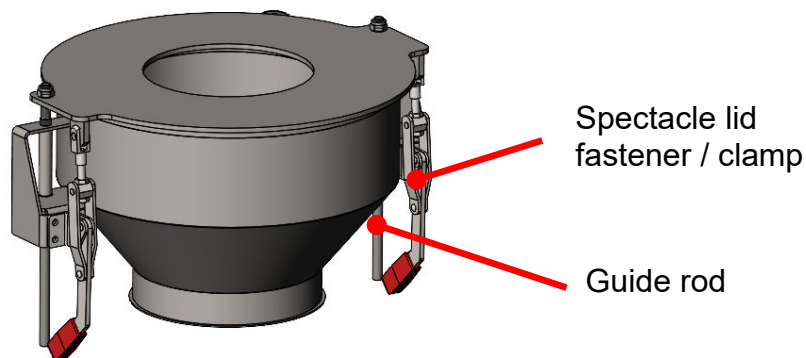

Fig.4.2.9

FIBC docking lid - open

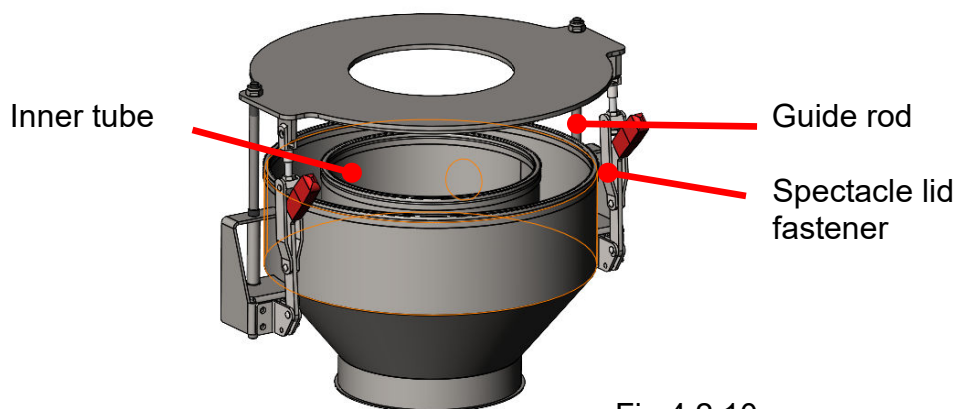

Fig.4.2.10

Images may differ slightly from reality.

This system is used for outlet hoses by  $\text{Ø}300 \times 500\text{mm}$  (1:1,6) lengths ratio if you have a shorter ratio than this one, better use the other docking devices.

The outlet hose will be feed through the hole in the middle of the spectacles lid.

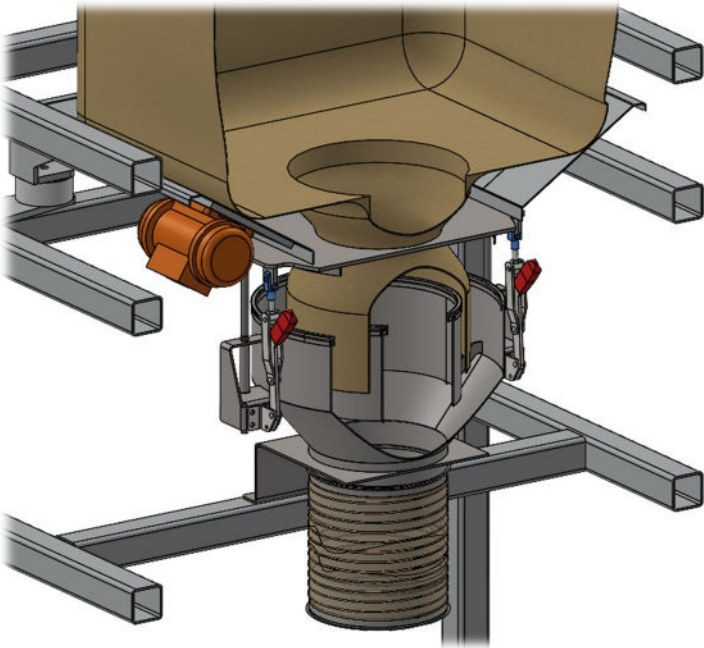

Fig.4.2.11

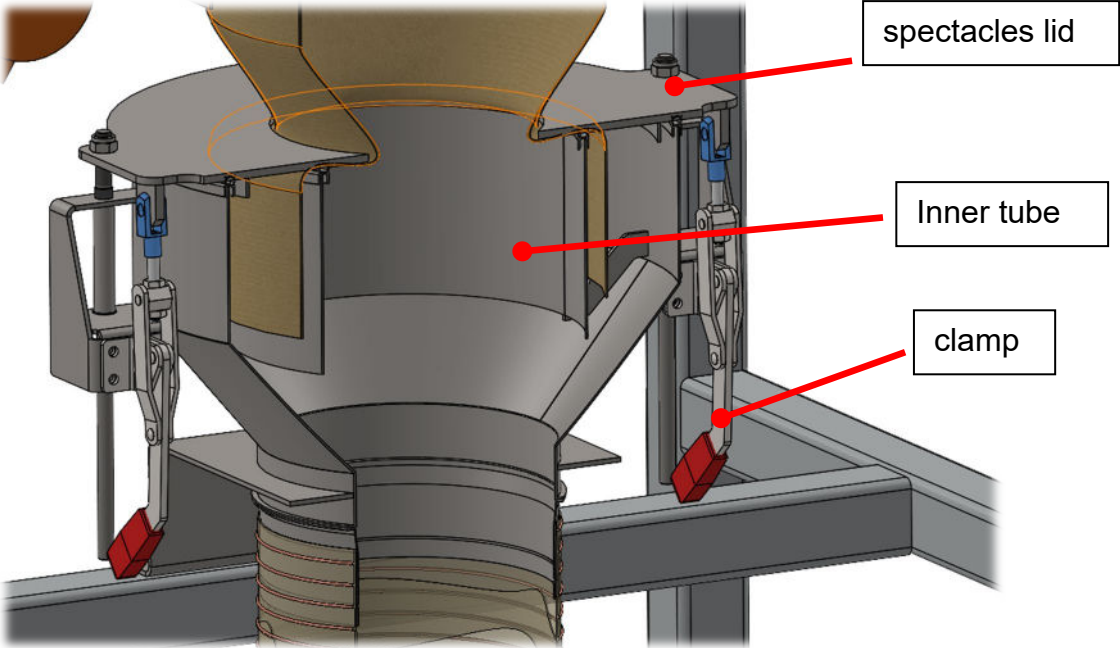

Fig.4.2.12

Images may differ slightly from reality.

#### 4.2.4 Inflating cuff 2.0 Ø200/Ø300 - DI2/DI3

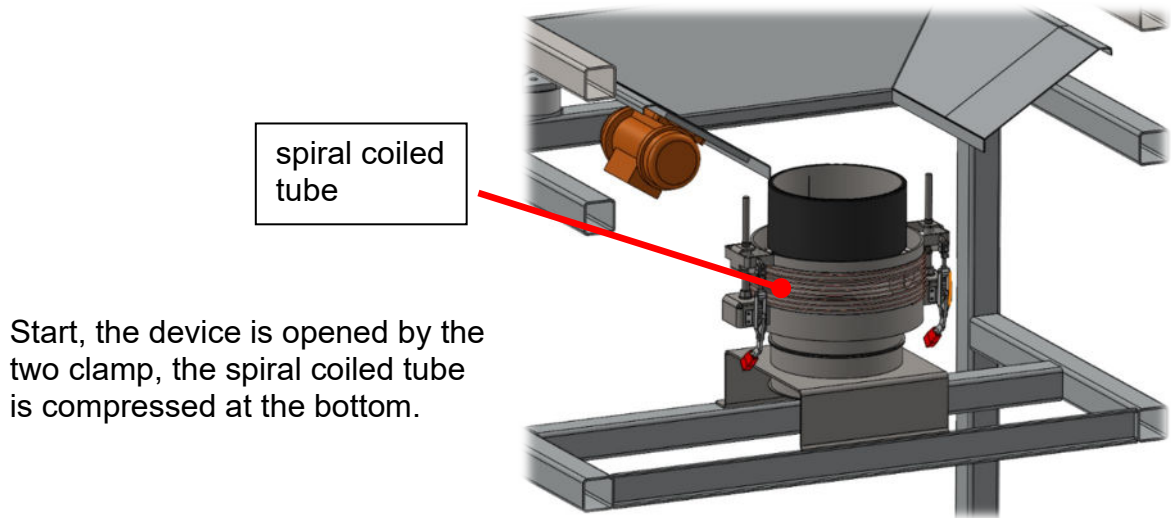

Fig.4.2.13

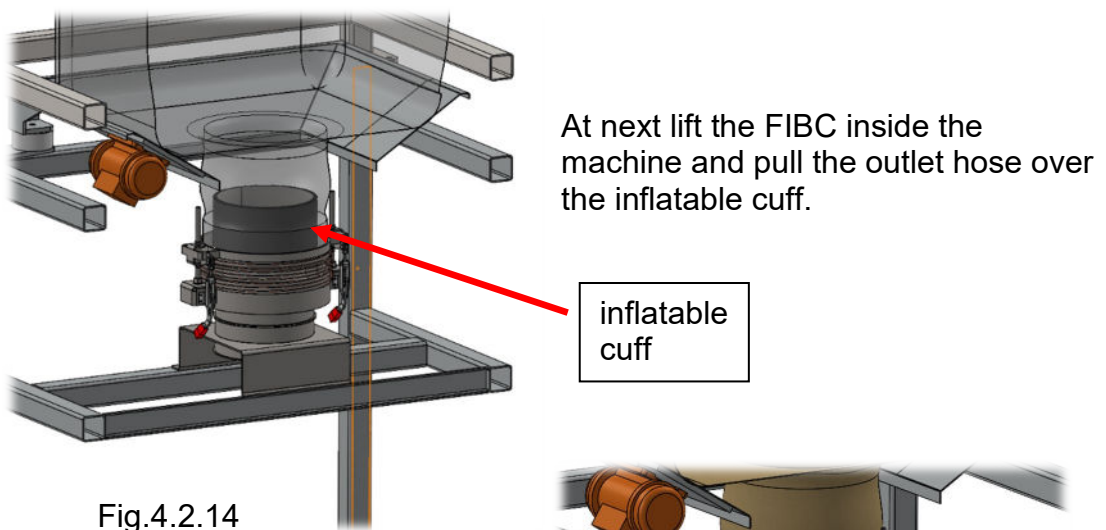

Fig.4.2.14

The FIBC outlet hose is in position  
Pull the ring with the spiral coiled tube up, with the two clamps

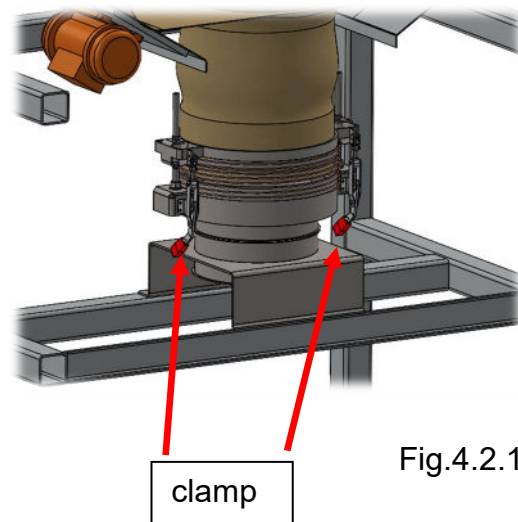

Fig.4.2.15

The ring is in position.  
It is important,  
otherwise the inflatable  
cuff can be damaged when  
inflated.

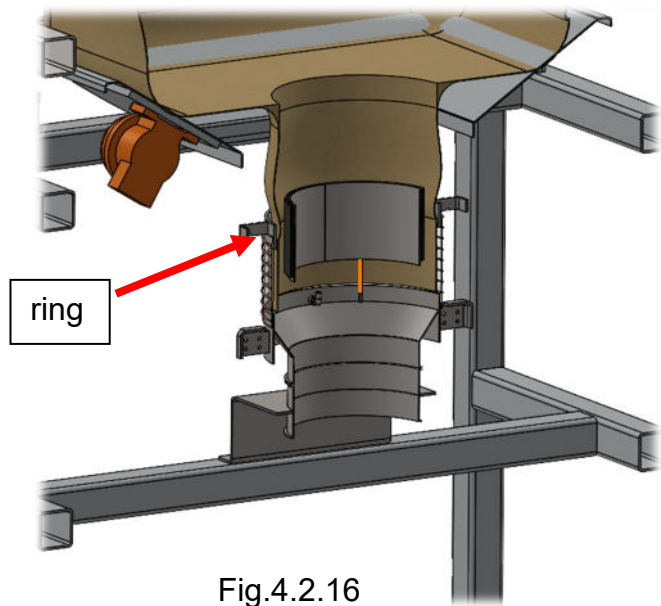

Fig.4.2.16

The cuff can now be inflated.

The outlet hose  
of the FIBC is  
fixed now.

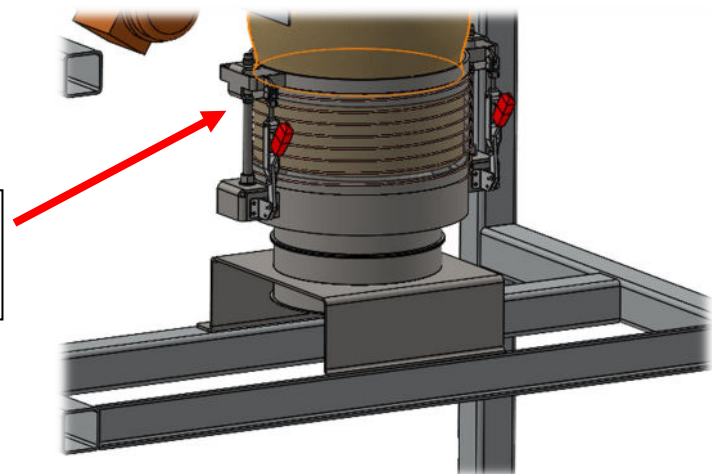

Fig.4.2.17

#### 4.2.5 Feed hopper - DF

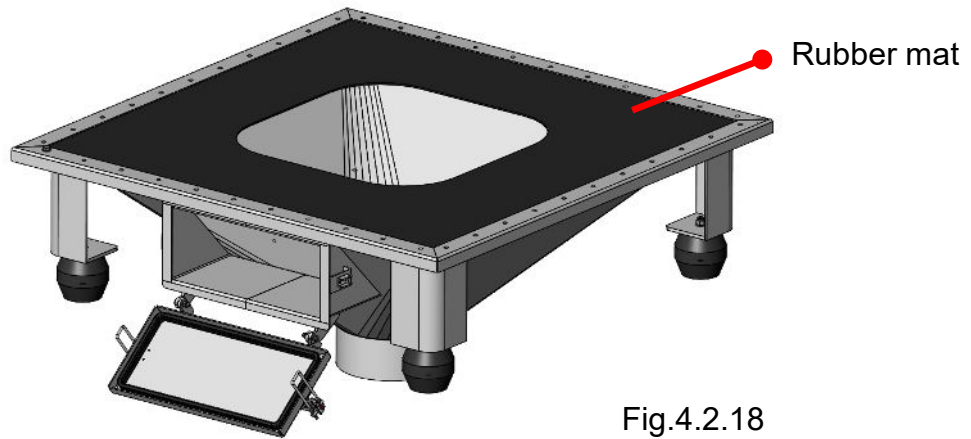

Fig.4.2.18

The bag will be placed at the rubber mat.  
The rubber mat is the seal which keep the dust Inside the hopper.  
To open the bag's outlet hose the operator open the flap and work on the hose through the funnel.  
When the house is open the operator have to close the flap.

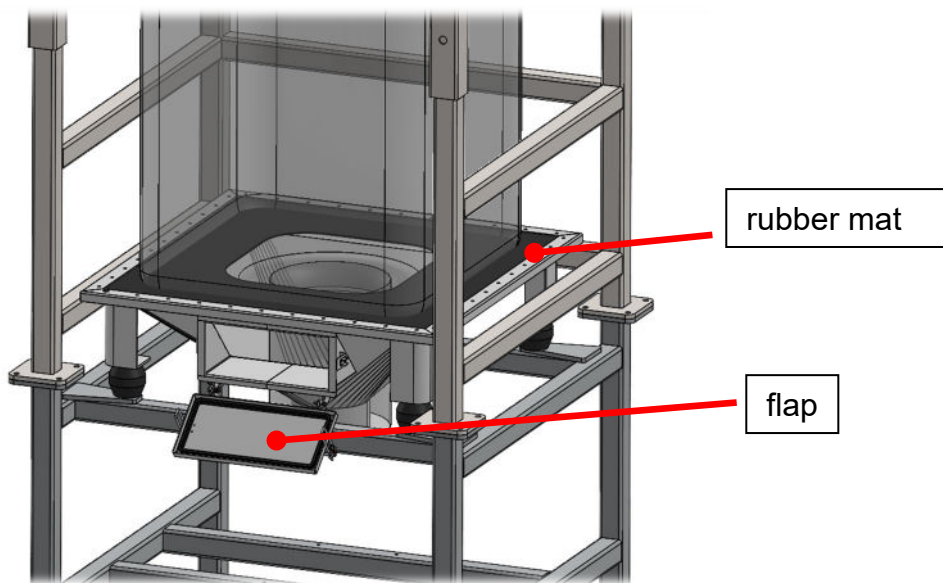

Fig.4.2.19

#### 4.2.6 Vibration motor - V

The imbalance motor is an option for difficult bulk, which get stuck in the FIBC and won't get out of it. The imbalance motor can be mounted on every funnel and feed hopper

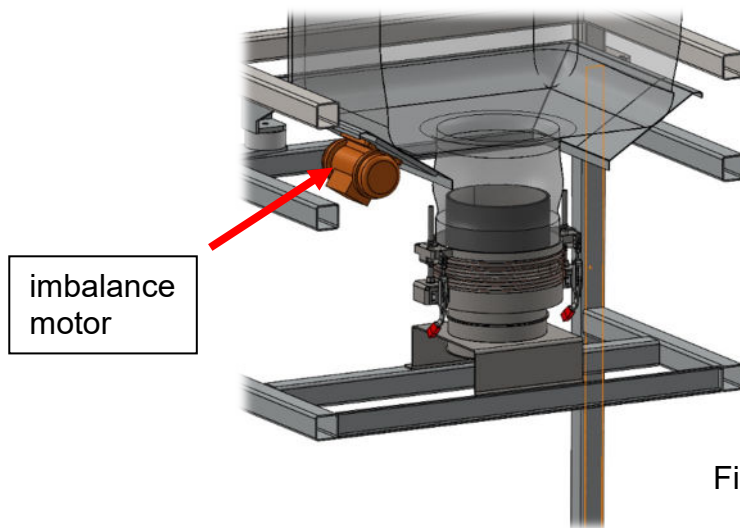

Fig.4.2.20

## 5 Maintenance and repair



### 5.1 General information

In order to ensure the safe operation of the Piab system, the following maintenance must be carried out at regular intervals. In addition to the maintenance and repair specifications in this chapter, the instructions in the documentation and data sheets of individual components (in the appendix) must be followed.

Maintenance and repair may only be carried out by appropriately trained personnel or by personnel with appropriate qualifications. For this purpose, the system must be shut down and secured against unintentional start-up (if necessary, disconnect supply connections).

Only original spare parts are to be used. Only tools and aids (e.g. lamps) that have the appropriate approval and protection class are to be used.

The operator must ensure that appropriate protective clothing (respiratory protection, gloves, shoes, clothing, etc.) is worn during maintenance in the case of products that are hazardous to health.

When dismantling system components, it is important to ensure that there are product residues inside the system.

The entire facility must be kept clean at all times. Dirt and dust deposits must be removed immediately. Cleaning components with compressed air can lead to damage and is prohibited.

Failure to comply with maintenance instructions and maintenance deadlines may result in accidents, damage to the Piab system, or premature wear and tear.

Failure to comply with the maintenance instructions and maintenance deadlines will result in the exclusion of the warranty.

## 5.2 Maintenance

| FIBC Emptying Station  | Maintenance<br>in operating hours[Bh] |        |             |           |
|--|---------------------------------------|--------|-------------|-----------|
|  | daily                                 | weekly | half-yearly | 1x a year |
| <p>Before carrying out any work on the station, it must be switched off and disconnected from the electrical and compressed air supply. Otherwise, there is a risk of injury and damage!</p> <p>To ensure a long service life and optimal operating conditions, the maintenance tasks listed in this table must be performed at the specified intervals.</p> |                                       |        |             |           |

| FIBC Emptying Station  | daily | weekly | half-yearly | 1x a year |
|--|-------|--------|-------------|-----------|
| Check that the environment is clean.                                   |       | ●      |             |           |
| Function control of the traverse                                       |       |        | ●           |           |
| Checking bolted connections  |       |        | ●           |           |
| Check the connection cable electric/pneumatic hose for damage          |       |        |             | ●         |
| Check the springs of the stretching device.                            |       |        | ●           |           |
| Check the functionality of the docking.                                |       |        |             | ●         |
| Check the connection between FIBC and docking device.                  |       |        |             | ●         |
| Inspection of Safety Functions (Emergency Stop, Safety Switches, etc.) |       | ●      |             |           |
| Media Supply of the System (Supply Voltage, Compressed Air, etc.)      |       | ●      |             |           |
| Check the base and upper frame for damage                              |       | ●      |             |           |

The specified values apply to single-shift normal operation.

### 5.3 Inspection of Pneumatics and Electrical Systems









Functionality and Safety Check (End Positions, Safety Shutdown, Emergency Stop, etc.) in Compliance with Operational Guidelines

- The entire system must always be kept clean.
- Contamination and dust accumulation must be removed immediately.
- Cleaning components with compressed air is prohibited.
- When dismantling system components for cleaning purposes, it must be ensured that any settled product dust inside is considered.
- Only tools and accessories (e.g., lamps) with the appropriate certification and protection rating may be used.
- Maintenance personnel must wear appropriate protective equipment (shoes, gloves, clothing, etc.) as required.

#### **Weekly Maintenance Tasks:**

- A visual inspection of all hoses and pipe connections for leaks must be conducted. If necessary, screw connections should be tightened with suitable tools.
- The air pressure of the pneumatic components must be checked.

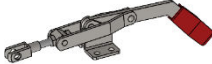
## 6 Spareparts

| Device                    | Peace | Description   | Order- No. |
|---------------------------|-------|---|------------|
| Feed hopper DF            | 1     | rubber mat<br>  | 0256520    |
| Feed hopper DF            | 4     | rubber buffer<br>  | 0256521    |
| Feed hopper DF            | 1     | Edge protection sealing profile 2,0-4,0 mm Typ M9010<br>        | 0256502    |
| Upper frame FA1/FA2/FA3   | 4     | Positioner bolt Ø25x150mm<br>                                   | 0256503    |
| Upper frame FA1/FA2/FA3   | 8     | Locking spring 5,0 x 85mm vz<br>                              | 0256504    |
| Spectacle closure DS2/DS3 | 1     | Edge protection sealing profile 2,0-4,0 mm Typ M9010 FDA<br> | 0256506    |
| Spectacle closure DS2/DS3 | 2     | Clamp<br>   | 0256507    |
| All funnel V              | 1     | Imbalance motor<br>  | 0256522    |

Images may exhibit slight deviations from reality.

| Device                      | Peace | Description  | Order- No. |
|-----------------------------|-------|--|------------|
| Inflating cuff<br>D12/D13   | 1     | Inflating rubber DI3<br>Ø300<br>                | 0256509    |
| Inflating cuff<br>D12/D13   | 1     | Inflating rubber DI2<br>Ø200<br>                | 0256510    |
| Inflating cuff<br>D12/D13   | 2     | Clamping device<br>                              | 0256511    |
| Inflating cuff<br>D12/D13   | 1     | Spiral coiled hose DI3<br>Ø450mm<br>             | 0256512    |
| Inflating cuff<br>D12/D13   | 1     | Spiral coiled hose DI2<br>Ø350mm<br>            | 0256513    |
| Inflating cuff<br>D12/D13   | 4     | Plain bearing with collar<br>                 | 0256514    |
| Inflating cuff<br>D12/D13   | 4     | Rubber buffer Ø125<br>for the FIBC funnel<br> | 0256515    |
| Travers for forklift<br>TF2 | 4     | Spring 380mm<br>                              | 0256516    |
| Travers for forklift<br>TF2 | 4     | Schaft hook<br>                               | 0256517    |

Images may exhibit slight deviations from reality



## EUROPE

### France

Lagny sur Marne  
+33 (0)16-430 82 67  
info-france@piab.com

Etampes (Joulin)  
+33 (0)1 69 92 16 16

### Germany

Butzbach  
+49 (0)6033 7960 0  
info-germany@piab.com

### Italy

Torino  
+39 011 226 36 66  
info-italy@piab.com

Due Carrare (Kenos)  
+39 049 874 13 84  
info-italy@piab.com

### Poland

Gdansk  
+48 58 785 08 50  
info-poland@piab.com

### Spain

Barcelona  
+34 (0)93-633 38 76  
info-es@piab.com

### Sweden

Danderyd (HQ)  
+46 (0)8-630 25 00  
info-sweden@piab.com  
+46 544 409 00  
se-sales@piab.com

Helsingborg  
+46 042-400 45 80  
se-sales@piab.com

Karlstad  
+46 054 55 80 90  
se-sales@piab.com

Mullsjö  
+46 392 497 85  
sales@avec.se

### United Kingdom

Loughborough  
+44 (0)15-098 570 10  
info-uk@piab.com

## AMERICAS

### Brazil

Sao Paulo  
+55 (0)11-4492 9050  
info-brasil@piab.com

### Canada

Toronto (ON)  
Lifting Automation  
+1 (0)905-881 16 33  
eh.ca.info@piab.com

Canton (MA, US)  
+1 800 321 7422  
info-usa@piab.com

### Mexico

Canton (MA, US)  
+1781 337 7309  
info-mxca@piab.com

### USA

Canton (MA)  
+1 800 321 7422  
info-usa@piab.com

Fairborn (OH)  
Robotic Gripping  
+1 888 727 3628  
info-usa@piab.com

## ASIA

### China

Shanghai  
+86 40 0897 8668  
info-china@piab.com

### India

Pune  
+91 8939 15 11 69  
info-india@piab.com

### Japan

Tokyo  
+81 3 6662 8118  
info-japan@piab.com

### Singapore

Singapore  
+65 6455 7006  
info-singapore@piab.com