

## OWECON OWL300 Series Load Cell



The OWECON Load cell Type OWL300 Series is an all new designed load cell to meet todays demands of wide webs, rotating live shaft applications in paper - and converting machines. Featuring a unique beam design, it is a very long life product.

The OWL300 is a block type load cell for use with a top mounted pillow block bearing, for very high load applications. Various load ratings available.

The OWL300 Series cover a load range from 100N to 50.000N

### Advantages:

- ✓ Compact, sleek design, clean closed surface. Aluminum housing, available in stainless steel.
- ✓ OWECON beam design ensuring very precise, repetitive performance and long life.
- ✓ All metric dimensions.
- ✓ Wash down duty, corrosive and chemical resisting
- ✓ Industry standard M12 connector.
- ✓ Easy to install.
- ✓ Price / performance competitive.

## Design specifications OWL300

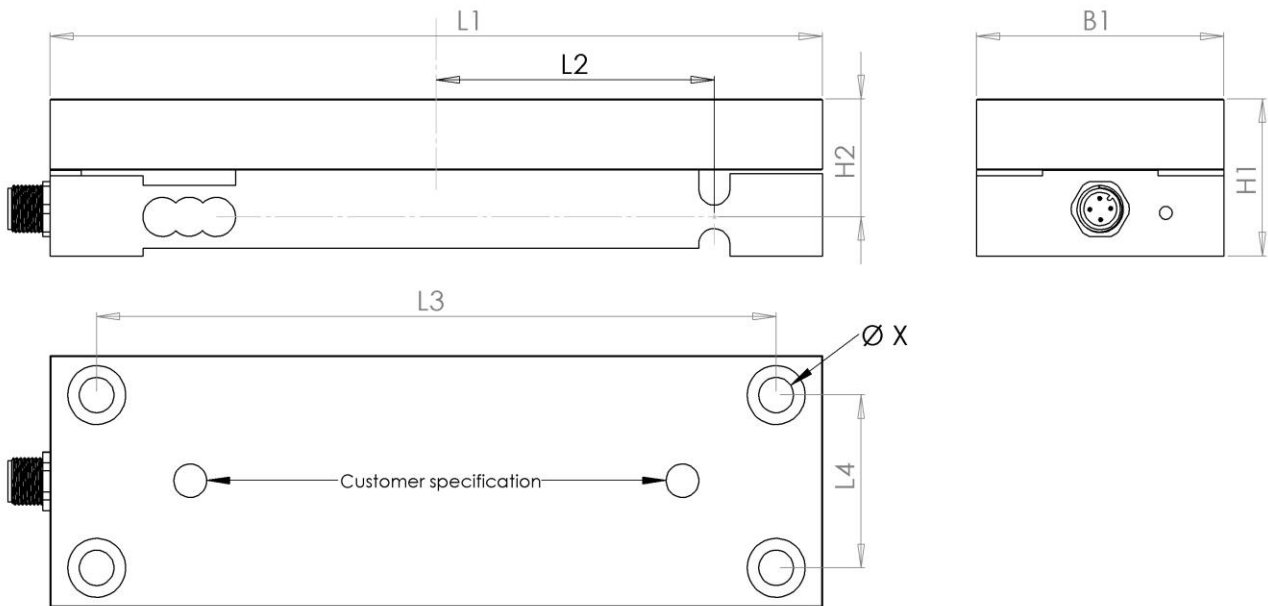

Dimension mm									
Typ	L1	L2	H1	H2	B1	L3	L4	X	Connector
OWL305	134	47	28	25	44	118	28	7	M12x1 on cable
OWL310	200	72	40	30	64	176	44	9	M12x1 integrated
OWL315	210	77	40	25	68	180	44	9	M12x1 integrated
OWL320	280	95	48	42	94	230	66	13	M12x1 integrated

Size	Nominal Force $F_n$									
OWL305	125N	250N	500N	1.000N						
OWL310			500N		1.250N	2.500N	5.000N			
OWL315					1.250N	2.500N	5.000N			
OWL320							5.000N	12.500N	25.000N	50.000N

### Specifications half bridge:

Max operating force relative to  $F_n$ .....150%  
 Overload capacity relative to  $F_n$  typical.....500%  
 Strain gauge resistance.....80 to 130 ohm  
 Strain gauge configuration.....half bridge  
 Supply.....5VDC  
 Nominal output.....50mV/V  
 Combined error relative to  $F_n$ .....< 0.5%  
 Temperature coefficient.....<0.4% / 10K  
 Operating temperature range.....-20 to +85°C  
 Deflection at  $F_n$ .....0.1 to 0.2 mm  
 Material finish.....Aluminum or Stainless steel

### Specifications full bridge:

.....150%  
 .....500%  
 Foil gauge resistance.....350 ohm  
 Foil gauge configuration.....full bridge  
 .....10VDC  
 .....1mV/V  
 .....< 0.5%  
 .....<0.4% / 10K  
 .....-20 to +85°C  
 .....0.1 to 0.2 mm  
 .....Aluminum or Stainless steel

**Dimensioning the OWL300 Load cell:**

The correct Load Cell load rating for an application is determined by maximum web tension, web wrap angle around the roller, and mass of the roll.

The force  $F_{(roll)}$  from the mass  $m_{(roll)}$  of the roll, is determined as

$$F_{(roll)} = m_{(roll)} \times 9.82 \text{ (N)} \quad (9,82 = \text{mass acceleration } m/s^2)$$

The force  $F_{(Load)}$ , from the web tension  $F_{(web)}$ , is determined as:  $F_{(Load)} = 2 \times F_{(web)} \times \sin(X/2)$

Force action arm  $H = H_c + H_2$

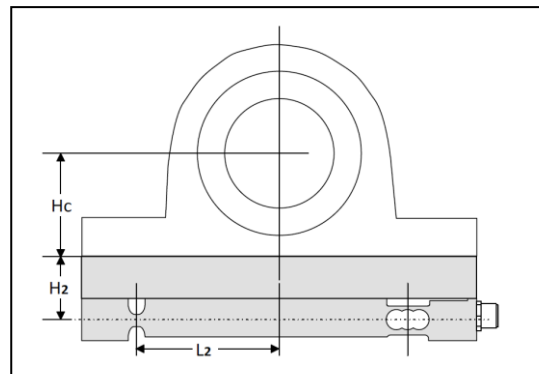
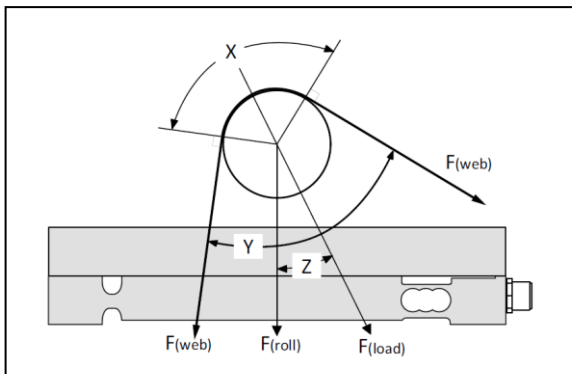

$$F_{(dim)} = \frac{2K F_{(Load)} (H \sin Z) (+/-)^* F_{roll} L_2}{2L_2} \quad (*: \text{ If } Z \text{ is below horizontal, use } "+" ; \text{ above horizontal, use } "-")$$

**Select the next higher nominal load for the right size of OWL300 load cell.**

**Note:**

The minimum load cell size must be  $> \frac{1}{2} \times F_{(roll)}$

For mounting situations different from horizontal or vertical, ask your OWECON team for advice.

$m_{(roll)}$  = The mass of the roller/shaft in kg;  $F_{(web)}$  = Maximum web tension;  $Z$  = Angle between  $F_{(Load)}$  and vertical;  $X$  = Web wrap angle;  $H = H_2 + H_c$  (center height of bearing);  $K$  = Transient safety factor(1.5);  $L_2$  = Center-Hinge distance (table page 2)

**Electrical connector:**

M12 - 4 pin male, Code A, IEC61076-2-101

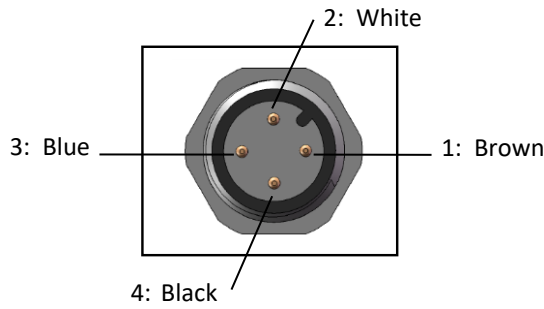

**Half bridge wiring diagram:**

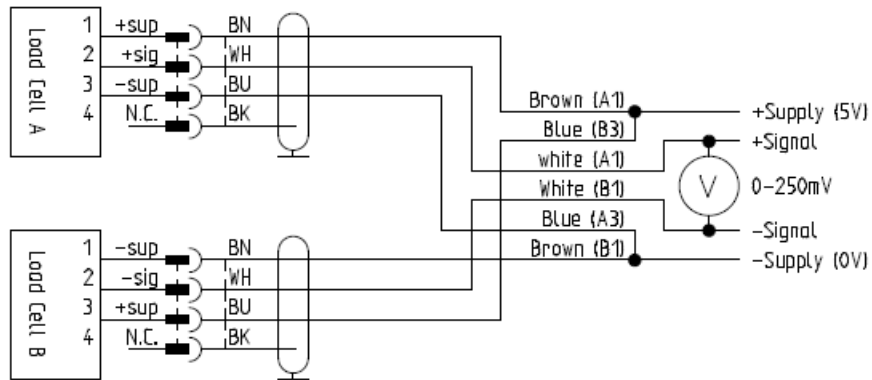

**Full bridge wiring diagram:**

