

MAI[®]440GE

HIGH-TECH FOR HIGHEST DEMANDS

The MAI[®]440GE is the result of decades of experience in different applications in tunnelling, mining and ground engineering. The universal concept of the machine allows large conveying distances and high pressure levels even when using materials which are difficult to be processed. A mortar mixing pump for users who put a high emphasis on process security.

The modular machine concept allows wet spraying with and without accelerators, filling, backfilling and grouting works with different pressure control options.

The dual mixing principle guarantees top mixing quality and allows variable flow rates for almost every application.

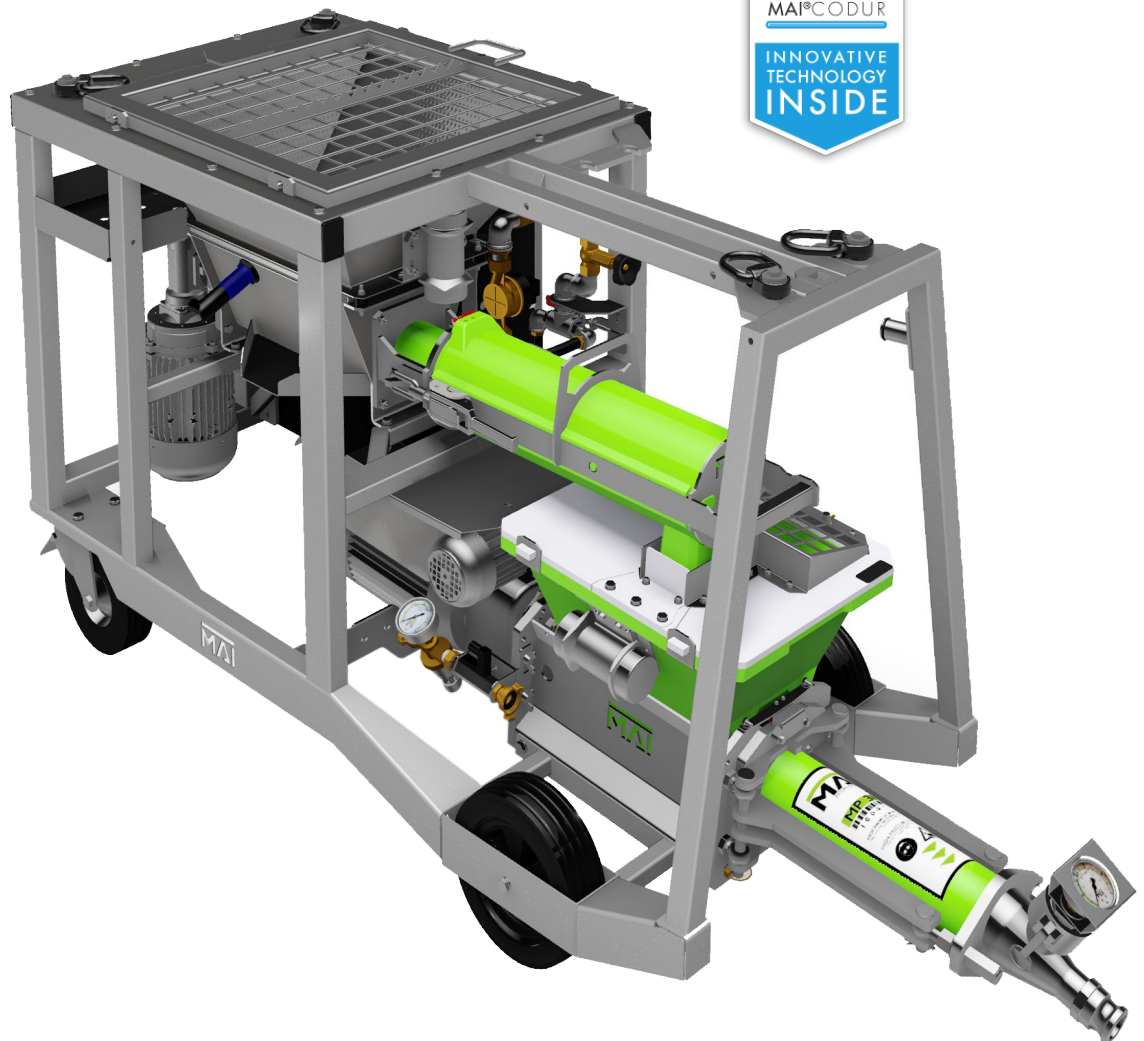

THE INDIVIDUAL IS OUR MAIN CONCERN

DEVELOPED BY PROFESSIONALS FOR PROFESSIONALS

The MAI®440GE is a further development of existing technologies, with the goal to develop a high-performance mixing pump, which sets new standards in process security. Flow rates from 5 to 60 liters / minute at operating pressures of max. 45 bar and hose lengths up to 100 m are possible. In addition to the easy and simple operation, the operating parameters of MAI®440GE can be individually set to the user's needs. The MAI®Codur plastic components used in the wet zone ensure optimal comfort of cleaning, as well as low wear.

IDEAL IN APPLICATION OF

- Injections ■ Concrete repair ■ Geothermal drilling ■ Tunnel repair ■ Backfilling ■ Grouting of tendons
- TBM (Tunnel Boring Machines) ■ Grouting

The robust MAI®440GE covers a broad spectrum of applications. This ranges from simple shotcrete or grouting for slope protection or in tunnel renovation projects, to geothermal injections. All these can be performed using the same machine. The application-specific adjustable pressure control programs allow high-quality injections as well as grouting of tendons. In combination with the MAI®LOG400, data such as pressure, injected volume, consumed water and time can be recorded and documented.

-
- 1 DUAL MIXING SYSTEM**, the separation of mixer and pump allows variable flow rates and prevents fluctuations in consistency at high pressures, and reduces screw pump wear.
 - 2 DRY MATERIAL PROBE** and water tolerance monitoring guarantee a constant mixing quality (no consistency fluctuations).
 - 3 MIXING ZONE** The patented mixing device secures homogeneous mixing satisfying highest demands.
 - 4 AGITATOR** prevents stiffening, segregation and tunnel formation of the mixed material in the pump hopper.
 - 5 MAI®CODUR** All components in wet zones are made of highly wear-resistant plastic and can be cleaned easily and residue free.
 - 6 OPERATION** via self-explanatory pushbuttons and switches
 - 7 MULTIFUNCTION-DISPLAY** informs about water settings, error messages and operating conditions and allows individual application-specific parametrisation as well as the selection of different pressure control programs, and emergency running functions.
 - 8 WATER SYSTEM** with adaptive pressure reducer for changing job site conditions. Its vertical layout enables automatic drainage and to prevent frost damage.
 - 9 STAINLESS STEEL HOPPER** guarantees high durability and corrosion protection.



Karl Dullnig (50)

Austria, head of road maintenance department

Spittal a. d. Drau

"I am responsible for 120 km of road in a very mountainous area. Our roads, retaining walls and bridges are constantly monitored to detect any damage and repair them immediately. As part of the renovation or new construction, we need a reliable machine which covers a broad range of applications. With the MAI®440GE, we have a reliable machine which we can use to perform grouting of retaining walls as well as small concrete repair- or shotcrete works. In addition to the ease of operation, the plastic parts impressed me most. They are extremely easy to clean and reassembled in no time.

Another great benefit for our work is, that the flow rate of the MAI®440GE can be adjusted by remote control. "

MAI®440GE IN DETAIL

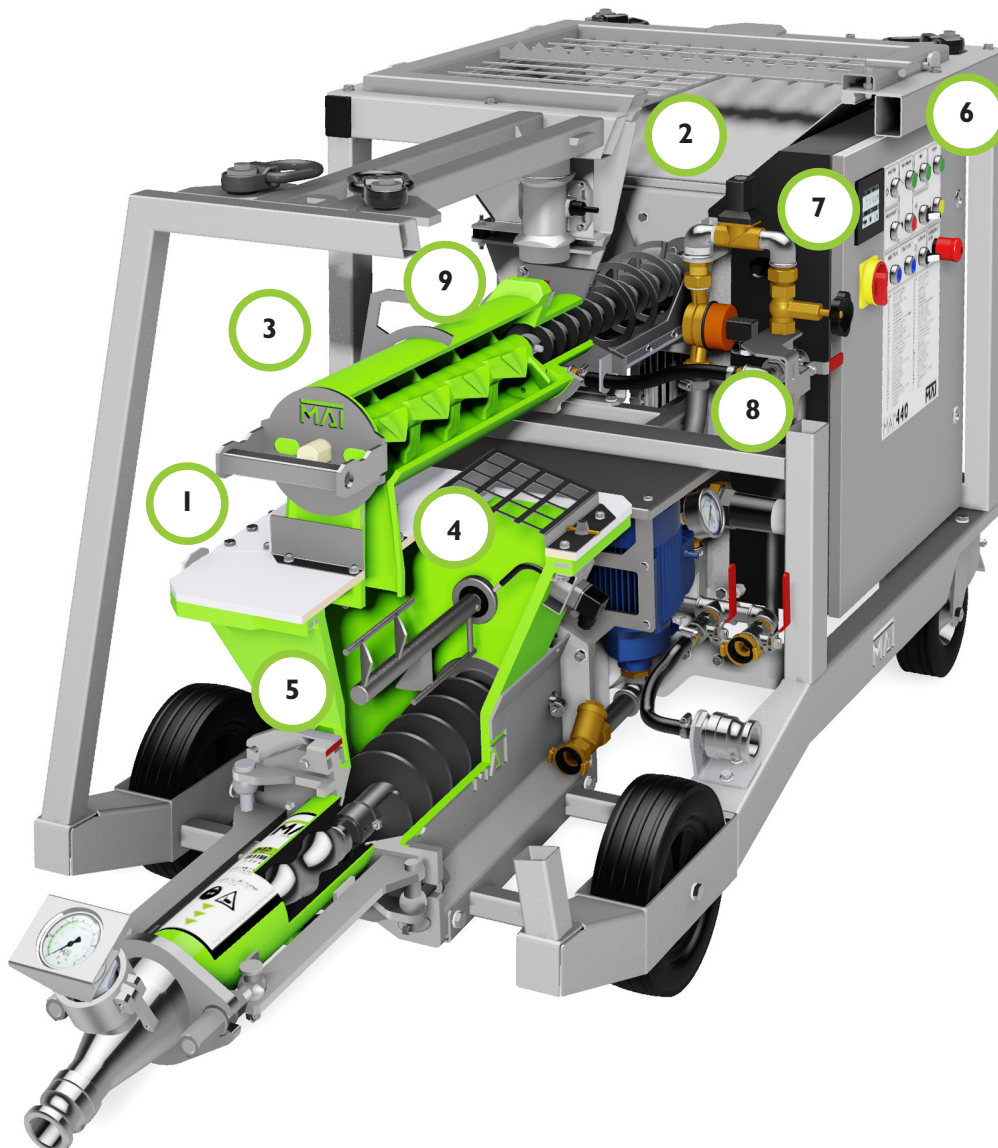

Applying shotcrete



Concrete Repair



Feeding from silo

THE INDIVIDUAL IS OUR MAIN CONCERN

BENEFITS AT A GLANCE

Highest process security

by dual mixing system and innovative water and dry material management.

One for all

the special machine design supports a broad range of applications.

Sustainable

due to stainless steel components, galvanized frame & wear resistant plastic components.

Comfortable cleaning,



because of modular and simply dismountable construction and the use of innovative MAI®Codur components.

Minimized machine downtimes,

achieved through automatic control, accurate indication of faults and simplified troubleshooting.

MAI SAVES TIME AND MONEY

MAI®440GE compared to standard mixer / pump systems.

 MAI Mixer/Pump	approx. 40%	Time saving, due to fully automatic continuous mixing no waiting periods.
 MAI Mixer/Pump	approx. 15%	Easier operation and handling, reduced error rate, because of automatic and controlled process flow.
 MAI Mixer/Pump	approx. 23%	Simplified cleaning, waste reduction, lower disposal costs and higher machine efficiency.

TECHNICAL SPECIFICATIONS

Operating voltage: 400V / 3 / PE / N / 50Hz
Rated power: 10 kW
Fuse: 32A
Flow rate: 5 to 50 l / min
Dimensions: 201 x 75 x 103 cm
Feeding height: 103 cm

WEIGHT

Total weight: 360 kg

INDIVIDUAL EQUIPMENT ACCORDING TO YOUR REQUIREMENTS

The MAI®440GE can, according to its intended use, be equipped with a compressor, different spray guns, filler guns, a hood for silo feeding, a dosing pump for additive dosage, pressure sensors for grouting, or the MAI®LOG for data recording.

