

Product Information

Tipper Flow Measuring Device *UFT-FluidTipper*

KI
0152

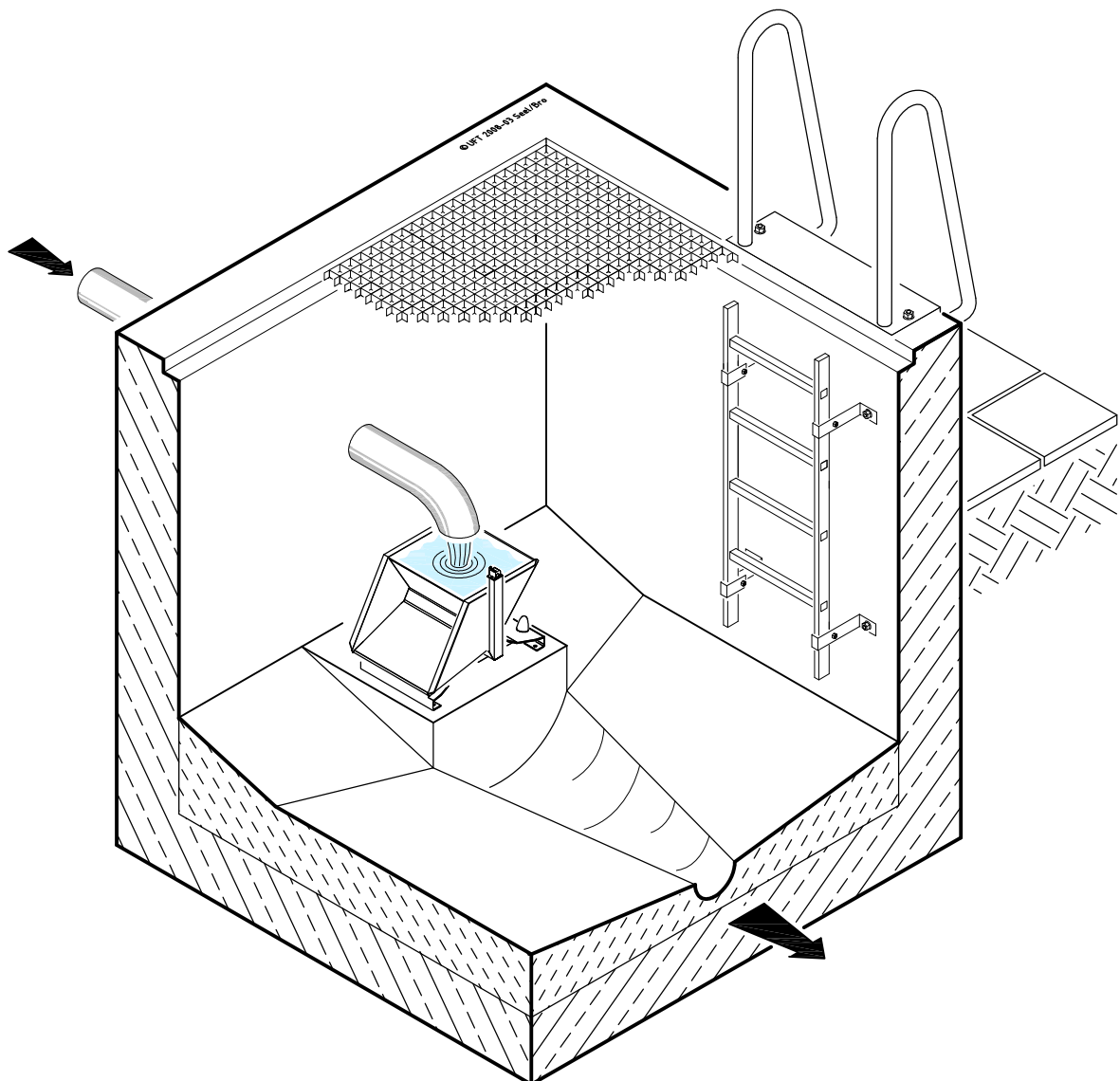

1 Application

Standard flow monitoring devices (such as inductive flow meters or Venturi orifice units) cannot readily perform the monitoring of small and very small flows. The flow velocity becomes too low to ensure a sediment-free operation. In addition, monitoring of very irregular or even intermittent flows is not feasible. The Tipper Flow Measuring Device UFT-FluidTipper is designed to collect small flows. The monitored flow can even fall to zero for a long period. However, over a certain period, an average flow is measured. The UFT-FluidTipper is a mechanical device requiring no external energy.

The Tipper Flow Measuring Device UFT-FluidTipper can be installed where measurements of small or very small flows with periodic stops and long monitoring must be carried out. Flows produced by a single household, small industry, flow produced by roof or parking catchments are all good applications for the Tipper Flow Measuring Device UFT-FluidTipper. Landfill or mine infiltration water or dam leaks can also use such a device.

2 Construction and Operation

The tipping bucket is in 304 Stainless Steel. The flushing angle is at 20° from the horizontal axis. This way, even highly loaded fluids can be reliably treated. The flow-measuring device is fitted with bearings on a stainless steel shaft safely located under the unit. The support is made of 304 Stainless Steel. The bumpers are made of special noise-reducing rubber. The mechanical meter is splash tight and corrosion resistant.

A filling pipe located right over the Tipper UFT-FluidTipper fills the unit's dual compartment semi-stable bucket. One of the two compartments is always in filling position, whereas the other is in tipped position and empty. As soon as the dripping liquid reaches the activation level of the compartment, the bucket tips and empties the liquid. The tipping takes place due to the displacement of the center of gravity of the

Advantages of the Tipping Flow Measuring Device UFT-FluidTipper

- designed to collect small and very irregular flows
- corrosion-free construction
- no external energy required
- low noise
- adapted to highly loaded fluids
- simple and quick installation
- suitable as mobile measuring device for temporary installation
- unit can be fitted with a magnetic switch and linked to a small control system

filled bucket. The released liquid is drained to the outlet, while the dripping liquid starts filling the other compartment now in place. A mechanical counting device records each filling cycle. The number of counts, multiplied by the volume of the two compartments, gives the flow per unit of time. After inspection, the meter can be set back to zero. As an option, the unit can be fitted with a magnetic switch to detect each filling cycle. The switch must be linked to a small control system that will count the pulses and record the information. The

magnetic switch can be supplied to meet explosion proof requirements.

3 Performance

We are producing the Tipper Flow Measurement Device with volumes from 2 to 40 litre by double fillings. The number of tipping cycles is limited to 900 per hour due to the toughness of the construction and the measuring accuracy. The maximum flow is shown in table 1.

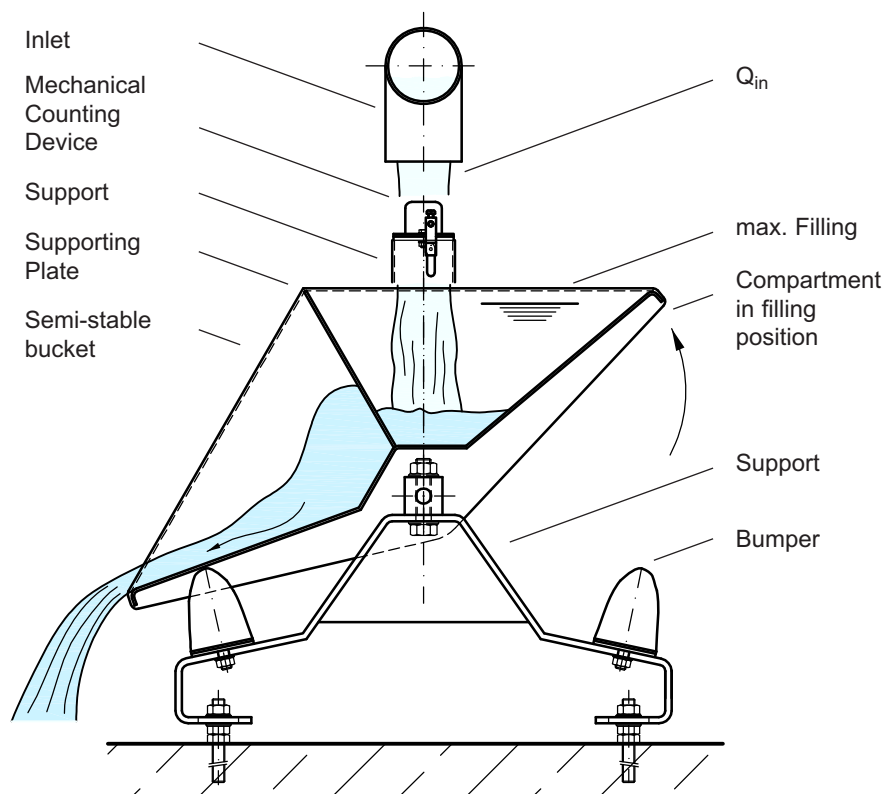

Fig. 1: Construction of the Tipper Flow Measuring Device UFT-FluidTipper

4 Accuracy

Each device is calibrated individually in our workshop before delivery. The measured volume of one double filling is noted on the name plate and a test certificate.

The accuracy is +/- 10% of the maximum flow – accurate installation assumed.

5 Installation

To insure a long trouble-free operation, the support of the UFT-FluidTipper device must be anchored properly. For temporary installation, the unit can simply be installed in position. However, the unit will require regular visual inspection to guaranty that the unit has not moved at the tipping of the bucket. The filling pipe is set between 20 – 40 mm above the higher edge of the tipping bucket. Insuring a proper liquid drainage under the UFT-Fluid-Tipper device is also mandatory.

6 Maintenance

After the first operating hours the bolts are to be checked and to be retightened if necessary.

In order to ensure the accuracy of the device in the long run the compartments will require visual inspection and removal of firmly bonded deposits.

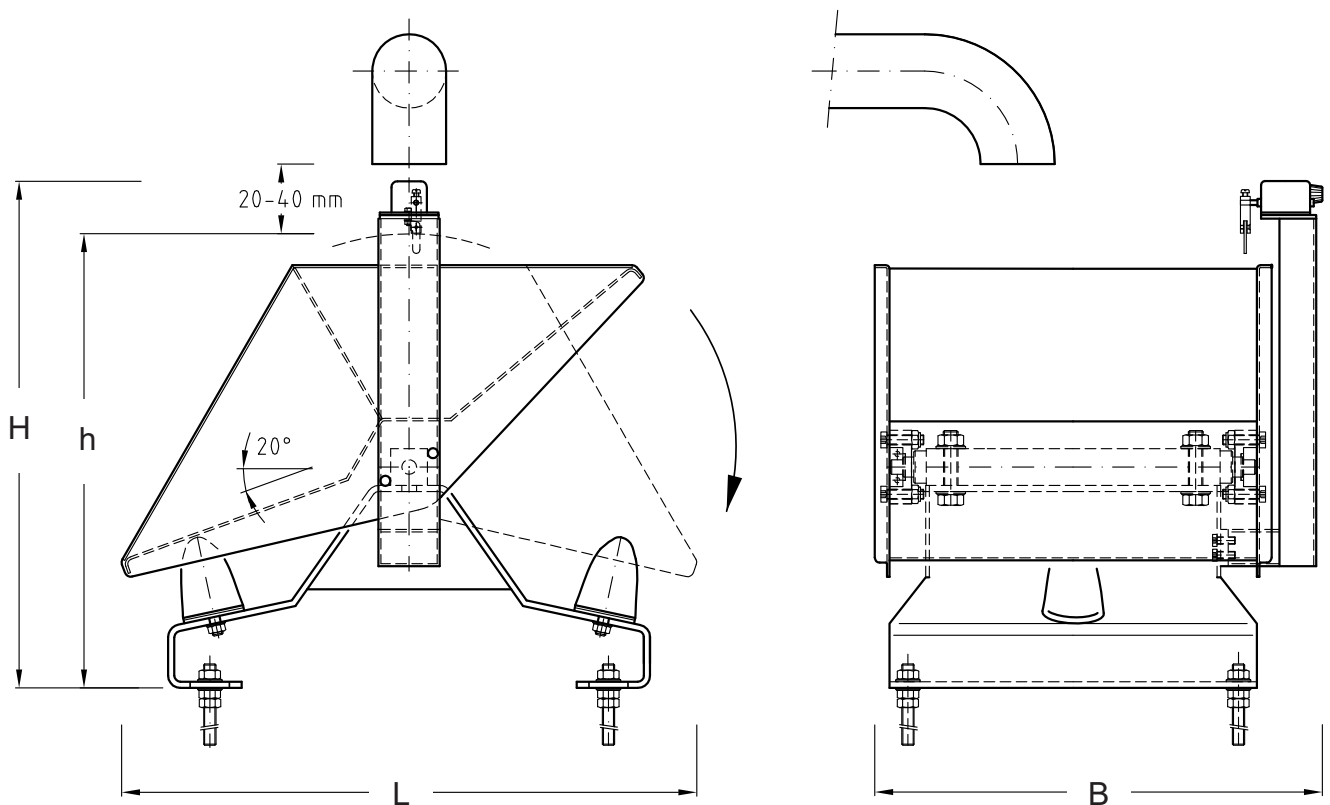

Volume V by double fillings	Maximum Flow		Length L in mm	Width B in mm	Hight H in mm	Swing hight h in mm	Weight in kg
	in m ³ /h	in l/s					
2 l	0,9	0,25	286	213	331	283	8
5 l	2,3	0,63	389	303	387	342	15
10 l	4,5	1,3	470	361	414	371	22
16 l	7,2	2,0	557	413	464	420	30
25 l	11,3	3,1	640	455	513	469	42
40 l	18,0	5,0	749	515	568	523	50

Table 1: Dimensions of the Tipper Flow Measuring Device UFT-FluidTipper



Fig. 2:
Tipper Flow Measuring Device UFT-FluidTipper with a volume of 16 litre by double filling. The unit is fitted with a magnetic switch to detect each filling cycle.