



# LEICA **SUMMILUX-TL** 35 mm f/1.4 ASPH.

Technical Data.



Illustrations 1:1

Lens	Leica Summilux-TL 35 mm f/1.4 ASPH.
Order number	Black anodized: 11 084 Silver anodized: 11 085
Compatible cameras	All Leica T models, Leica SL (Typ 601)
Field angle (diagonal, horizontal, vertical)	45°/38°/26°, corresponding to approx. 50 mm focal length in 35 mm format
Optical design	Number of lenses/groups: 12/8 Aspherical surfaces: 4 Position of entrance pupil at infinity: -49.1 mm
Distance setting	Setting/Function: Electronically controlled Mode selectable using camera menu: Automatic (AF) or manual (M), in AF mode manual override possible at any times with setting dial Focusing range: 0.4 m to ∞ Smallest object field/largest scale: 220 x 147 mm/1:9.4
Aperture	Setting/Function: Electronically controlled, adjustment using dial on camera, third values also available Lowest value: 16
Bayonet fitting	Leica L bayonet
Filter mount/ Lens hood	Internal thread for E60 filters, filter mount does not rotate, external bayonet mount for lens hood (included)
Finish	Black/silver anodized
Dimensions and Weight (without/with lens hood)	Length to bayonet mount: approx. 77/123 mm Largest diameter: approx. 70/81 mm Weight: approx. 428/498 g



# LEICA **SUMMILUX-TL** 35 mm f/1.4 ASPH.

ENGINEERING DRAWING

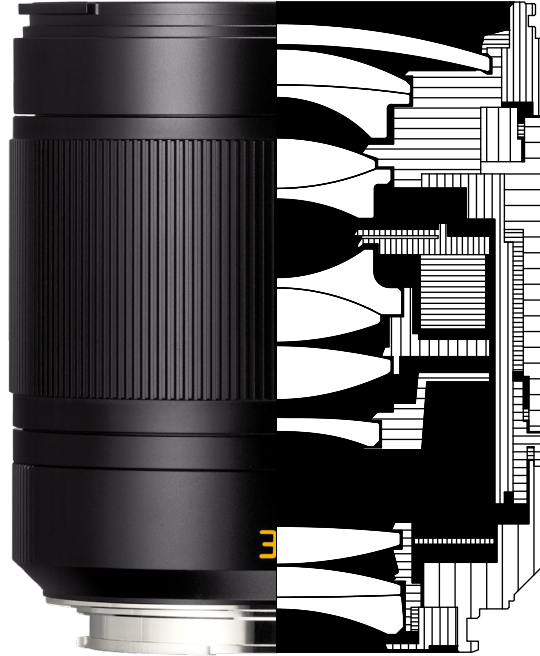
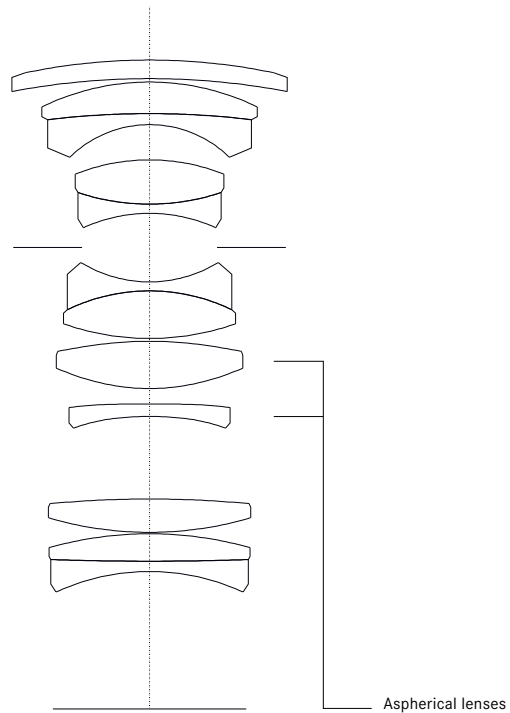

Illustration 1:1

LENS SHAPE





# LEICA **SUMMILUX-TL** 35 mm f/1.4 ASPH.

## MTF DIAGRAMS

### Focal length 35 mm

#### Infinity

#### Close focus distance

Aperture stop 1.4

Aperture stop 1.4

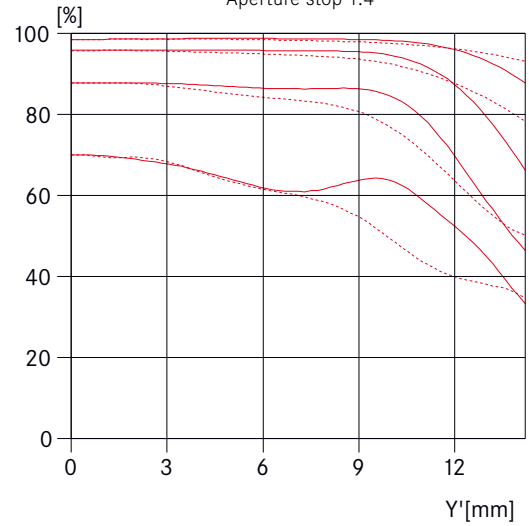
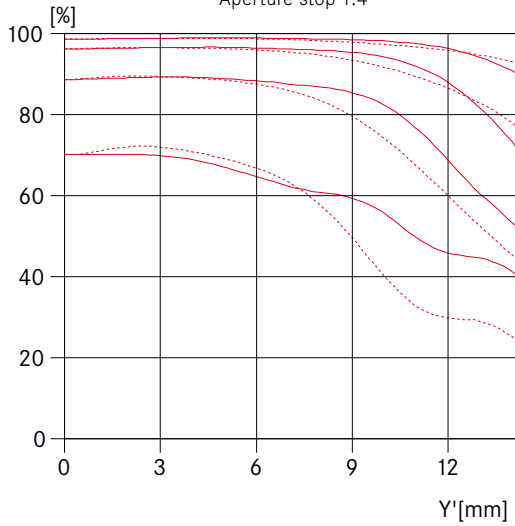

Aperture stop 5.6

Aperture stop 5.6

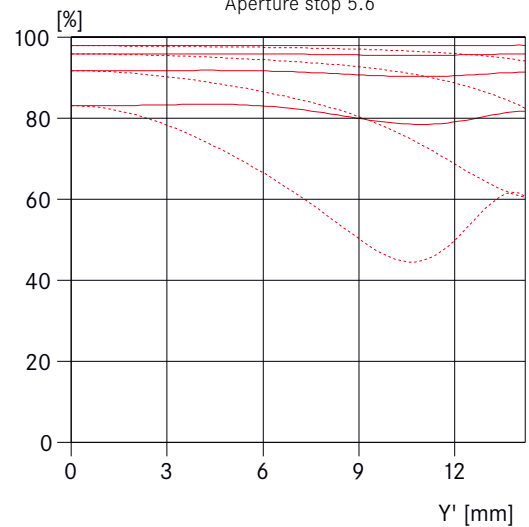
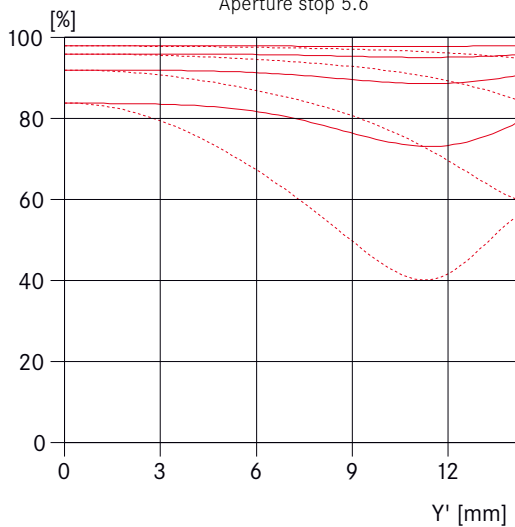

— Sagittal structures  
 - - - Tangential structures

## MTF GRAPHS

The MTF is indicated both at full aperture and at f/5.6 for long distances (infinity) and close focussing distance. Shown is the contrast in percentage for 5, 10, 20 and 40 lp/mm across the height of the 35 mm film format, for tangential (dotted line) and sagittal (solid line) structures, in white light. The 5 and 10 lp/mm will give an indication regarding the contrast ratio for large object structures. The 20 and 40 lp/mm records the resolution of finer and finest object structures.