



Recommended Practices for wind/PV integration studies

from international collaboration IEA WIND Task 25 and IEA PVPS Task 14

Hannele Holttinen, Principal Scientist, OA Task 25



Contents

- Introduction: On Task 25/Task14 work
- Recommendations for how to perform integration studies
 - Impact on balancing
 - Impact on generation adequacy
 - Impact on grid adequacy and resiliency
 - Damian Flynn, UCD: Transmission systems
 - Markus Kraiczy, Fraunhofer IEE: Distribution system





IEA-PVPS Task 14

Solar PV in the 100% RES Power System

- Promote the use of grid connected PV as an important source in electric power systems also on a high penetration level where additional efforts may be necessary to integrate the dispersed generators in an optimum manner.
- Develop and verify technical requirements for PV and electric power systems to allow for high penetrations of PV systems interconnected with the grid
- Discuss the active role of PV systems related to energy management and system control of electricity grids
- Reduce the technical barriers to achieve high penetration levels of distributed renewable energy systems on the electric power system

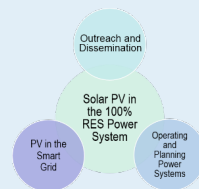
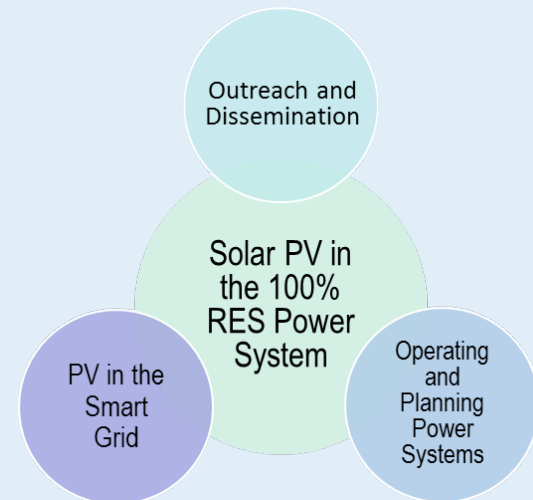



IEA-PVPS Task 14: Outcomes

- Prepare the technical base for Solar PV to become an integral part of the future 100% RES supplied power system through
 - guidelines and best practices for industry, network operators, energy planners as well as authorities
 - transparent technical analyses
 - comprehensive international studies for high penetration PV
- Develop key methodologies for large scale PV integration
 - Grid interconnection studies and planning
 - Technical standards and interconnection requirements
 - Integration with the Smart Grid
- Active dissemination of objective and neutral high-quality information
 - Task 14 Reports
 - Task 14 Workshops at national and international events
 - National information networks of Task 14 members
- Further information: <http://www.iea-pvps.org/>

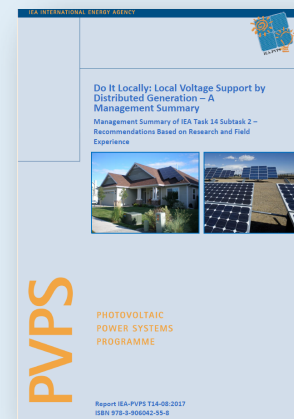
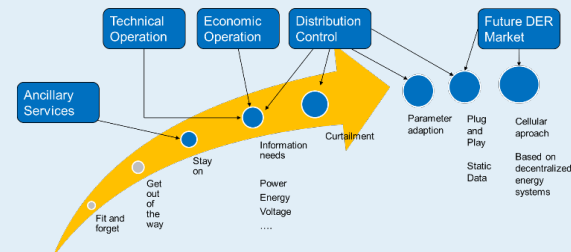

IEA Wind Task 25 – What Does It Do?

- Started in 2006, now 17 countries + WindEurope participate to provide an international forum for exchange of knowledge
- State-of-the-art: review and analyze the results so far: **latest report end 2018**
- Formulate guidelines- Recommended Practices for Integration Studies: **Update published in August**
- Fact sheets and wind power production time series. Literature list.
- <https://community.ieawind.org/task25/>



Task 25 Fact Sheet

WIND INTEGRATION ISSUES

Large Amounts of Wind Power

Design and Operation of Power Systems with Large Amounts of Wind Power

Final summary report, IEA Wind Task 25, Phase three 2012–2014

How is wind power different from other generation?

The main characteristics that differentiate wind power from other forms of generation are its variability and its uncertainty.

- Conventional power plants generate at specified levels that operators can vary up or down as needed—they are dispatchable (except in cases of operational failure).
- Wind power generation varies depending on how wind facilities. However, the variations in output are smoothed when many wind power plants are aggregated over an area in a power system (Figure 1).
- To deal with uncertainty, wind power output can be forecast minutes, hours, and even days ahead. Forecasts for minutes or a few hours ahead are more accurate than for 12 to 48 hours ahead. Aggregating wind power plants over a wider geographic area will improve the forecast accuracy at all time frames.

See Fact Sheet: Variability and Predictability of Large-Scale Wind Power

How do operators balance wind plant output? Does wind power need dedicated back-up?

Electric power systems experience varying electricity consumption (demand), as well as failures that cause power plants to go off line; all of these are balanced together with wind power.

To balance the variations in demand and supply, system operators adjust the output of some plants. In this way demand is met at all instants and demand and supply are balanced.

- Variations of system demand and wind output often cancel each other out. Sudden, large changes of wind and demand are rare and not likely to occur simultaneously.

Figure 1: The short-term variations of the single turbines output (top) are smoothed when aggregated to the output of a group of wind plants (middle). Aggregation of the output from all turbines in one many different countries, the variations even more. (Source: Task 25 summary report, 2009)

Agency Report on Integrated Practices for Integration Studies

Executive Committee Agency Implementing Agreement for High Development, and Deployment Energy Systems

1 Sept. 12, 2013

Experience of wind integration is increasing

- Hourly maximum wind shares in European countries
 - Denmark and Portugal > 100%
 - Germany 80 %
 - Ireland > 60 % of demand
- Wind energy in Europe :
 - Ranges 5-52% of installed capacity,
 - max duration of low generation: hours < 10% of capacity

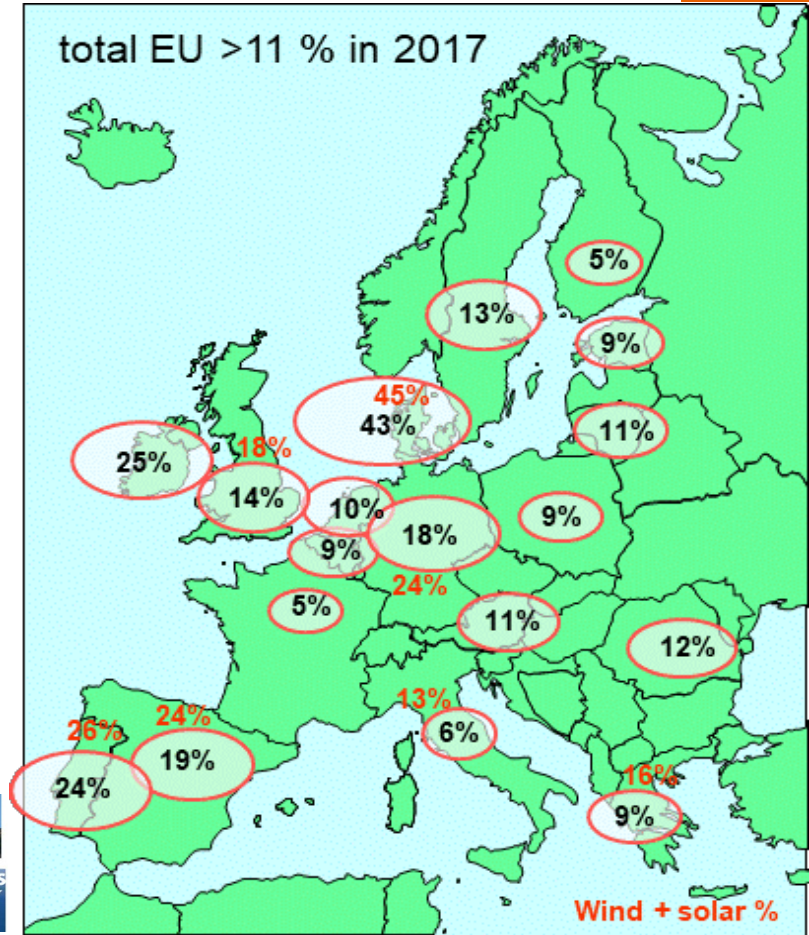

Recommended Practices for wind/PV integration studies

- A complete study with links between phases
- Most studies analyse part of the impacts – goals and approaches differ

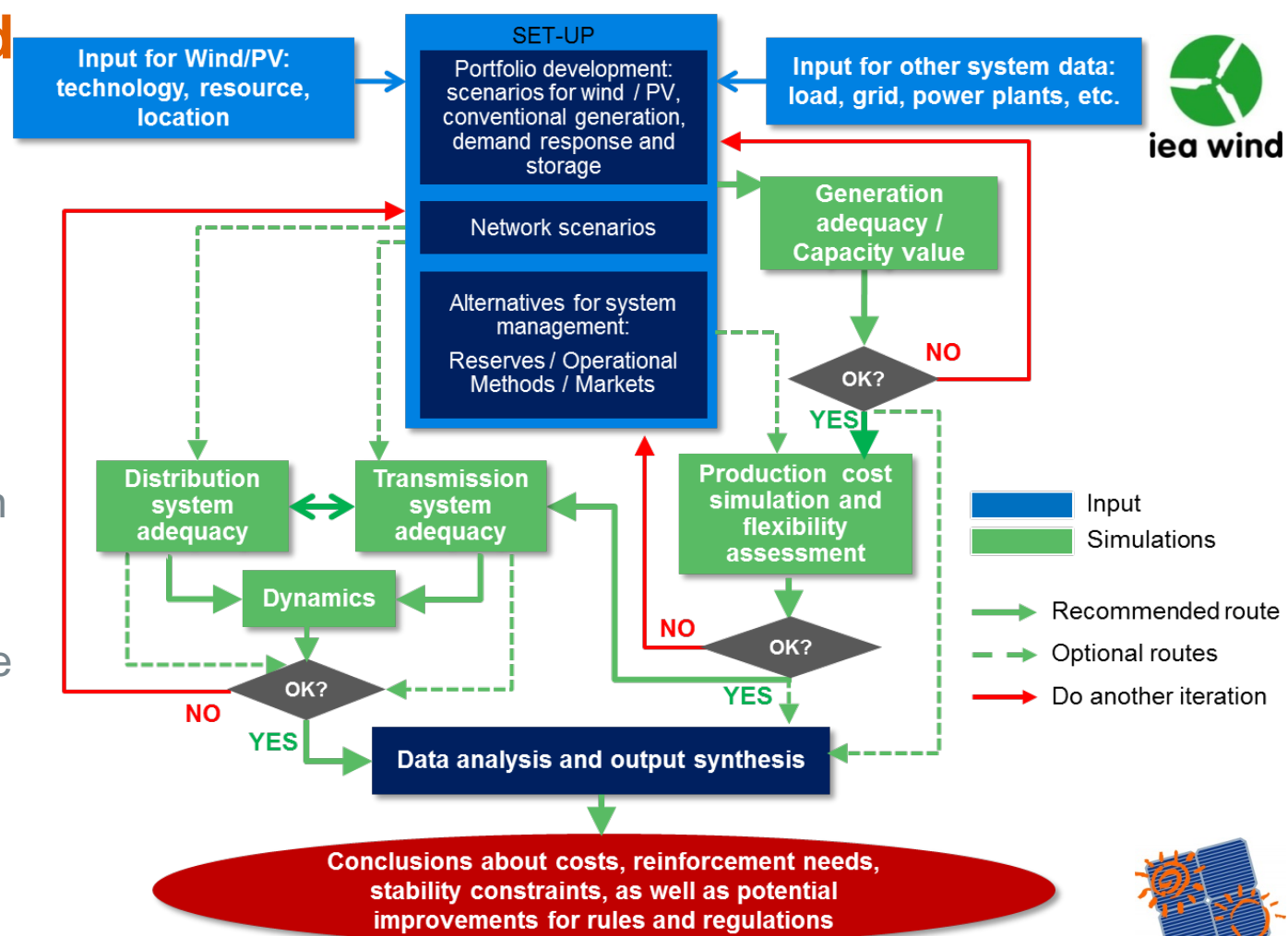

What to study - Portfolio Development and System Management

- Set-up of study
- Main assumptions – Critical for results!
- Future system, how wind/PV is added, what is remaining generation mix, operational practices

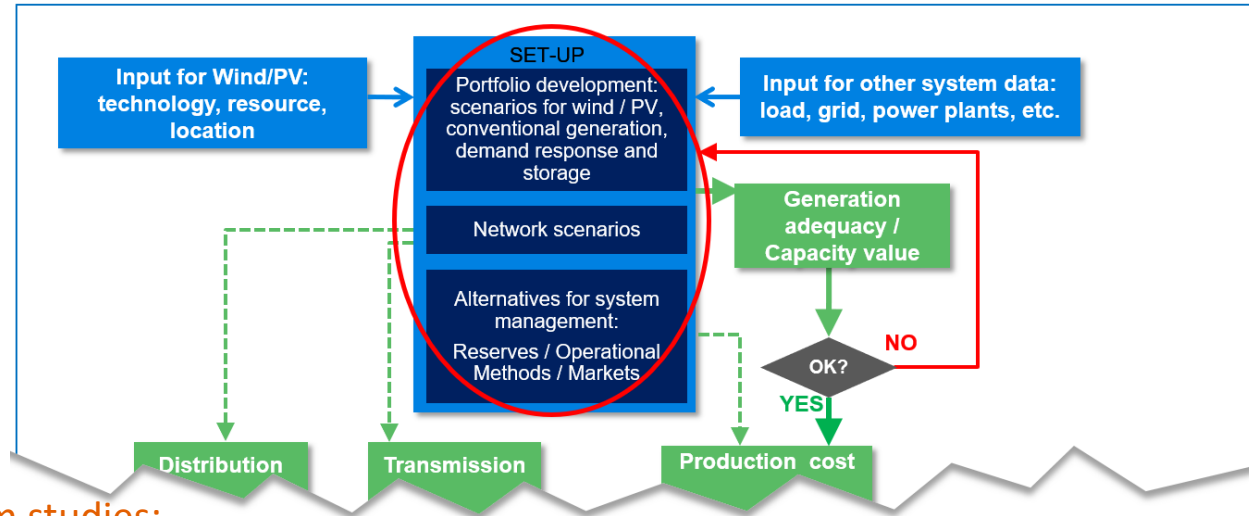

For larger shares and longer term studies:

- changes in the assumed remaining system become increasingly necessary, and beneficial: generation portfolio and network infrastructure, taking into account potential flexibility and technical capabilities of power plants. Additional scenarios for operating practices recommended



Input data

	Capacity Value/ Power (resource) Adequacy	Unit Commitment and Economic Dispatch (UCED)	Power Flow	Dynamics
Wind/PV	Hourly generation time series for distributed wind/PV energy covering the area. Especially for wind, more than 10 years recommended	5-minute to hourly generation time series of at least 1 year for distributed wind/PV power covering the area	Wind/PV capacity at nodes, high and low generation and load snapshots, active and reactive power capabilities	Wind/PV capacity at nodes, high and low generation and load snapshots, dynamic models, operational strategies
Wind/PV Short-term Forecasts	Not needed	Forecast time series, or forecast error distribution for time frames of UCED	May be needed in future	Not needed
Load	Hourly time series coincident with wind/PV data, at least 10 years recommended	5-minute to hourly time series coincident with wind/PV, of at least 1 year	Load at nodes, snapshots relevant for wind/PV integration	Load at nodes, high and low load snapshots, dynamic capabilities
Load Forecasts	Not needed	Forecast time series, or forecast error distribution for time frames of UCED	May be needed in future	Not needed
Network	Cross border capacity, if relevant	Transmission line capacity between neighboring areas and/or circuit passive parameters	Network configuration, circuit passive and active parameters	Network configuration, circuit parameters, control structures
Other Power Plants	Rated capacities and forced outage rates	Min, max on-line capacity, start-up time/cost, ramp rates, min up/down times. efficiency curve, fuel prices	Active and reactive power capabilities, system dispatch	Dynamic models of power plants

Operating reserve allocation with wind/PV

1. Synchronous wind/PV and load time series + forecast error distributions + generation outage distribution
2. Calculate for appropriate time scales, f.ex. automatically responding (secs-mins) and manually activated (mins-hour). Split data for categories with care not to double-count
3. Combine uncertainty keeping the same risk level before and after wind/PV
4. With increasing shares, use dynamic, not static reserves

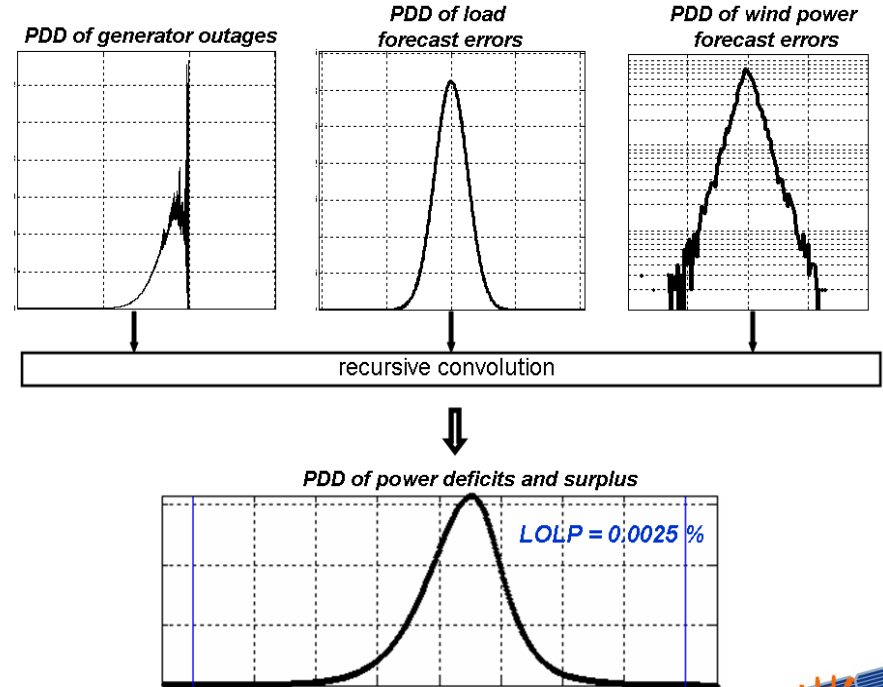

Generation capacity adequacy

- Needed for making consistent future scenarios (how much capacity will wind/PV replace), as integration study result: capacity value of wind or solar PV
- Recommendations:
 - How much increase in load will bring same reliability/LOLP in the system when adding wind or solar (ELCC method) recommended
 - Input data – synchronous wind/PV/load data. Number of years critical for robust results, more than 10 years

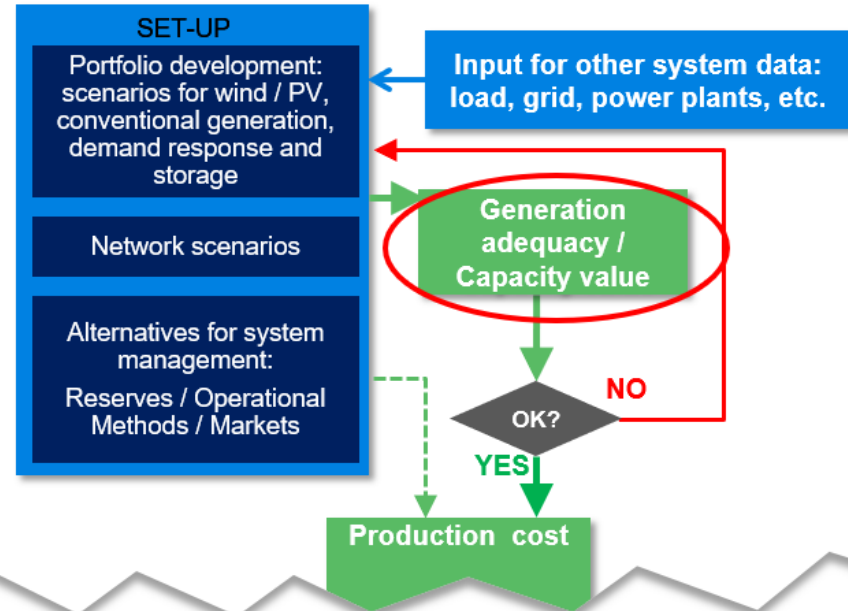

Production cost simulation – flexibility assessment

- Impact of wind/PV on other power plants' operation. Simulated with Unit Commitment and Economic Dispatch (UCED) tools
- Iteration loops /sensitivities often needed: results sensitive to base case selection (non-wind/PV case of comparison)
- Input data: one year of hourly wind/PV data – synchronous with load (and hydro) and capturing smoothing impact and forecast accuracy

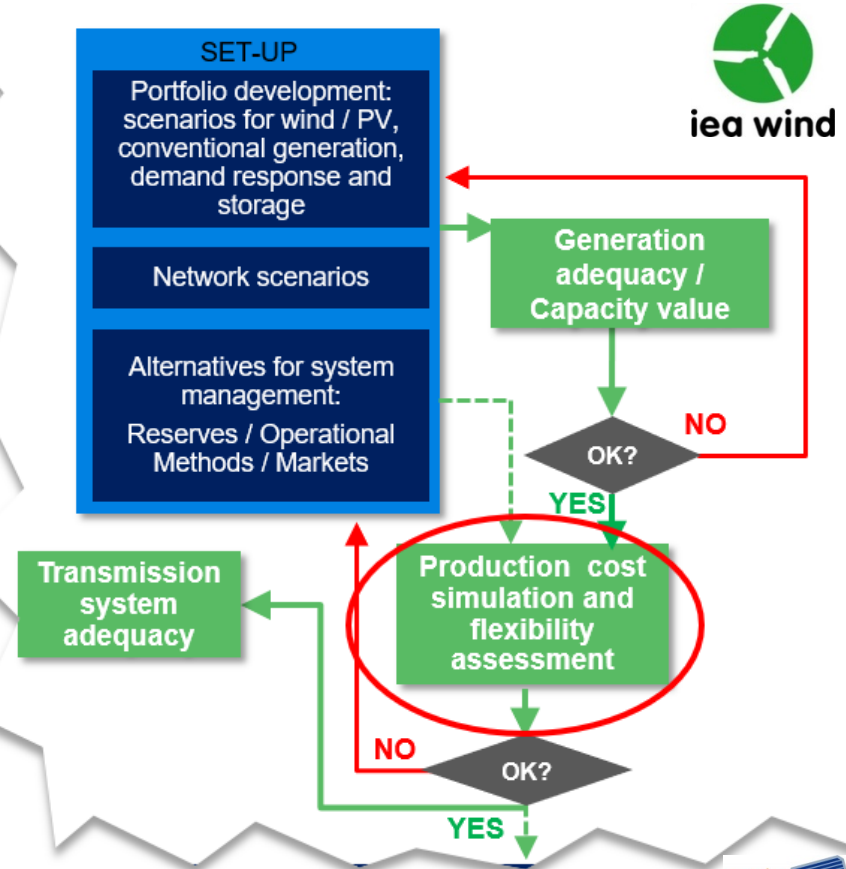

Recommendations for Unit Commitment and Economic Dispatch (UCED)

1. Impact of uncertainty on commitment decisions with possibilities to update forecasts (rolling planning)
2. Increased operating reserve targets
3. Flexibility limitations and constraints: min.generation levels, ramp rates, part load efficiency,..
4. Possible new flexibilities (power2heat, EVs, storages, demand response, dynamic line rating)

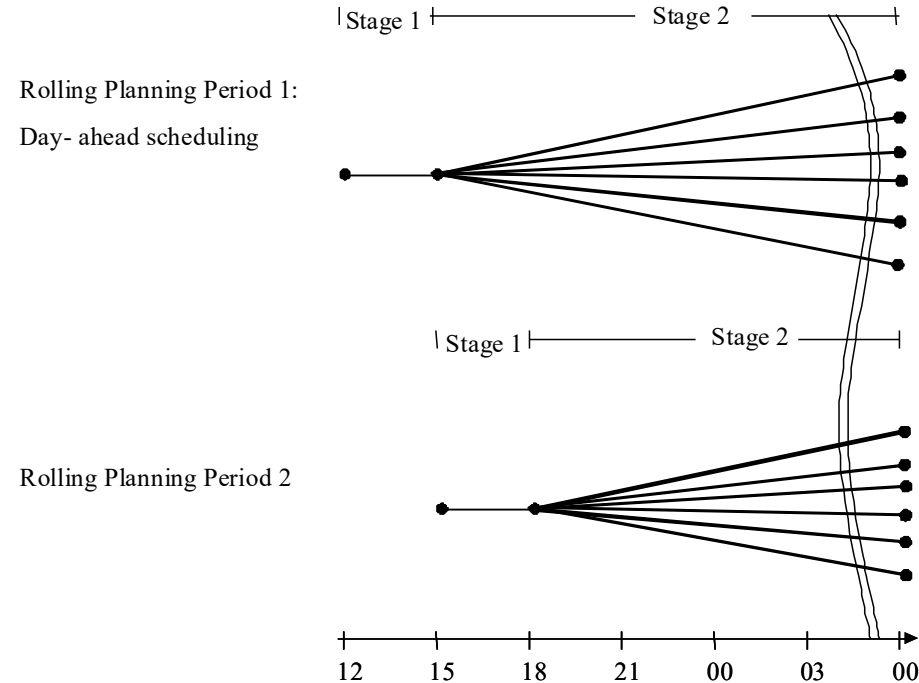

Recommendations for Unit Commitment and Economic Dispatch (UCED)

5. Possibilities and limitations of interconnections
 - model neighbouring system or mention assumption (over- or underestimating transfer possibilities)
6. Limitations from the transmission network require modeling of congestion and N-1 security
 - Net transfer capacity, or iterative methods can be used. Additional stability constraints for very high wind/PV shares.

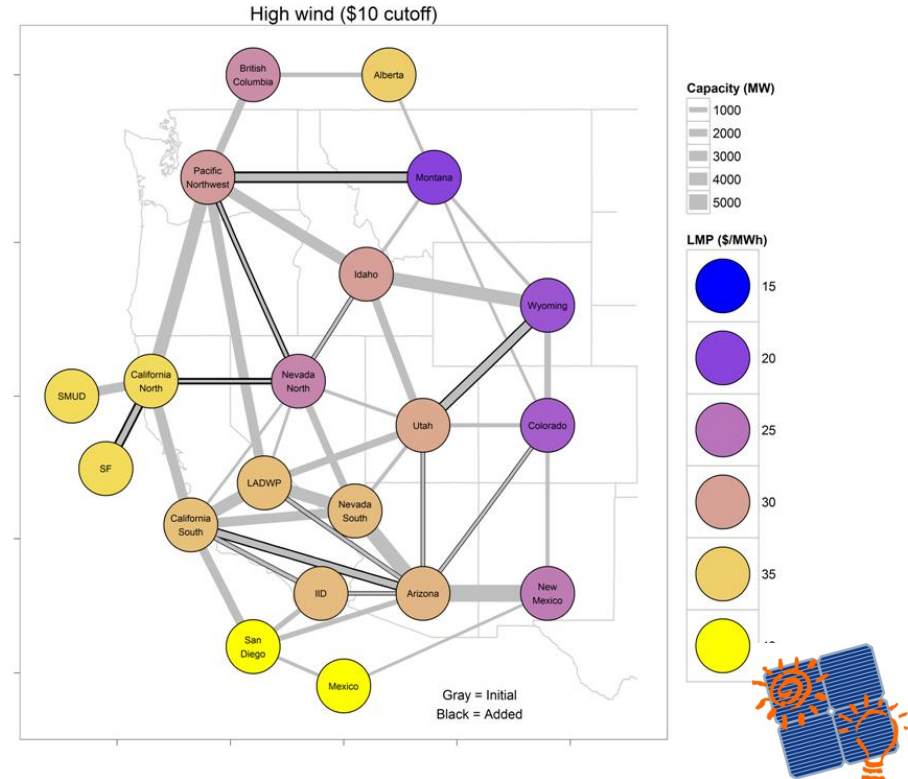

Transmission Grid and System Dynamics

Recommended Practices for Wind / PV Integration Studies

Damian Flynn, University College Dublin



High Wind / PV Share Concerns



- Displacement of synchronous machines
 - Low online inertia levels / regional inertia? \approx frequency stability
- Reduced fault levels \approx system strength
 - Impact on voltage stability / PE controls performance / power quality / ...
- Reduced synchronising torque \approx rotor angle stability
 - Exchange of surplus wind / PV power across wide areas
- Reduced Q / voltage regulation capability (static & dynamic)
 - Negative effect on voltage and transient stability
- Harmonic injections introduced by PE converters
 - Resonance amplification introduced by the new HV/EHV cables
 - Harmonic distortion at PoC, and wider network, within planning levels?

Locational Shift in Generation



- Large share of PE generation connected to Dx network
 - Voltage regulation capability from dx connected generation?
 - Operating at leading pf? Voltage profile on long + low X/R lines?
 - Reactive power requirements at TSO / DSO interface?
- Loss of mains protection for distributed generation
 - RoCoF relays for low inertia systems?
- Spatial distribution of *old* / *new* generation relative to load
 - *Old* generation near high capacity transmission circuits
 - *New* generation in remote, electrically weak locations?
- Buildout of network much slower than wind / PV growth
 - Network congestion / stability issues / ...
 - Real-time operational challenges?

Growth of PE based Loads



- Voltage & frequency dependent behaviour of evolving load
 - Constant power loads \approx frequency stability?
- Proximity of load to distributed generation
- Growth of large data centre connections
 - Short project delivery times
 - Strict power quality and reliability requirements
 - Limited knowledge of dynamic behaviour (+ protection)
 - Limited knowledge of harmonics emissions

Methodology

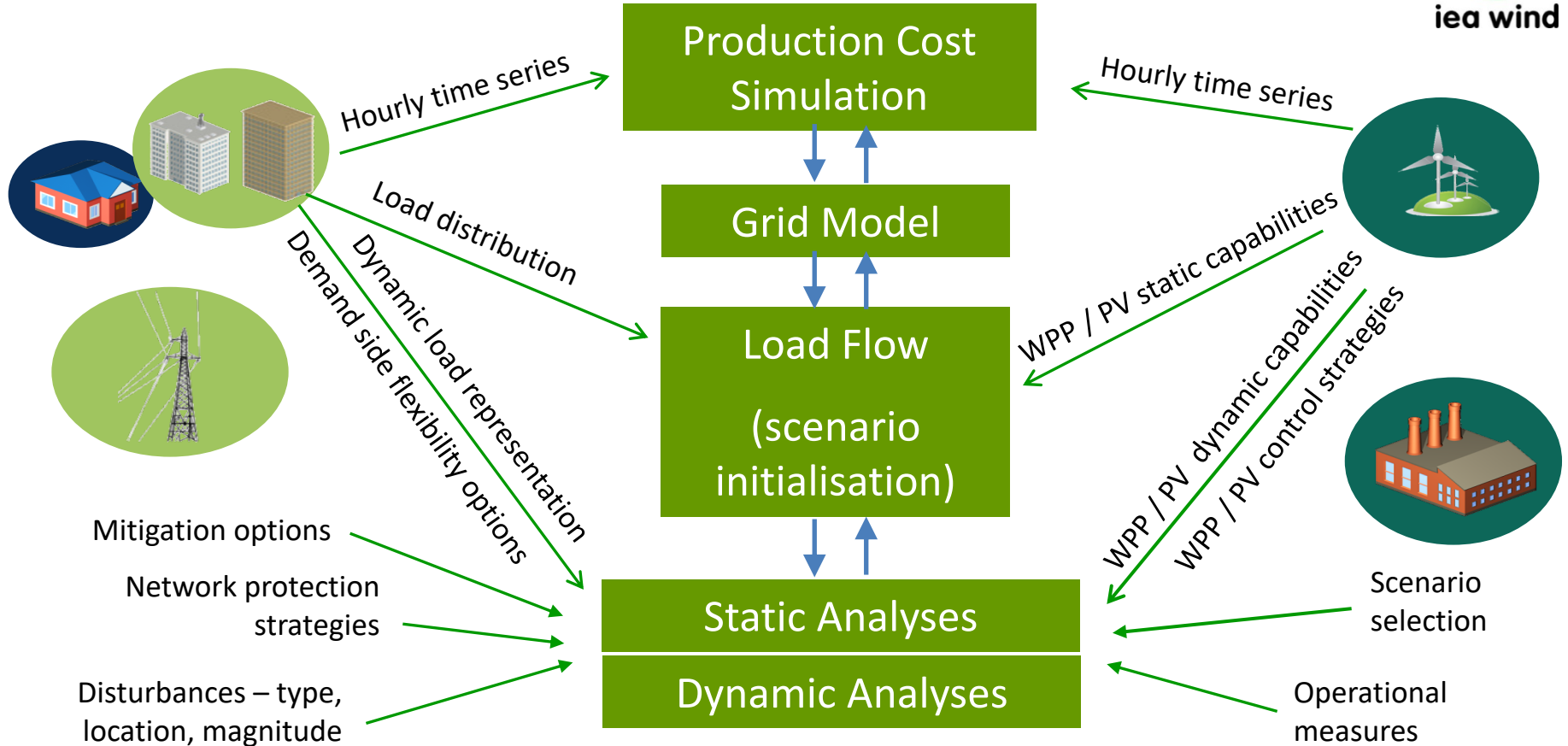

Stability Analysis



- **Transient stability (i.e. angle stability)**
 - ability to maintain generator synchronism when subjected to a severe transient disturbance
- **Small-signal (oscillatory) stability**
 - ability to maintain steady-state conditions on voltage, current, and power magnitudes after being subject to a small disturbance
- **Frequency stability**
 - ability to maintain the system frequency following a major imbalance between generation and load
- **Voltage stability**
 - ability to maintain an acceptable voltage profile after being subjected to a disturbance

Scenario Selection



- High / low demand – winter / summer
 - Extracted from production cost simulations
- High / low wind and / or solar power output
- High / low import / export
- Recognise correlation between inputs
- Multi-year evaluation of wind / PV scenarios
- Static scenarios \neq dynamic scenarios
- Likelihood of scenario occurrence

Scenario Selection



- Reverse power flows
- Full / empty (energy) storage
- High / low (synchronous) inertia
- High / low online headroom (P & Q)
- Displacement of stabilising controls
- ...
- Revisit scenario selection as results emerge
 - High-level scanning \Leftrightarrow in-depth focus
 - Selection of *before* vs. *after* scenarios?

Ireland - Synchronous Inertia 2020

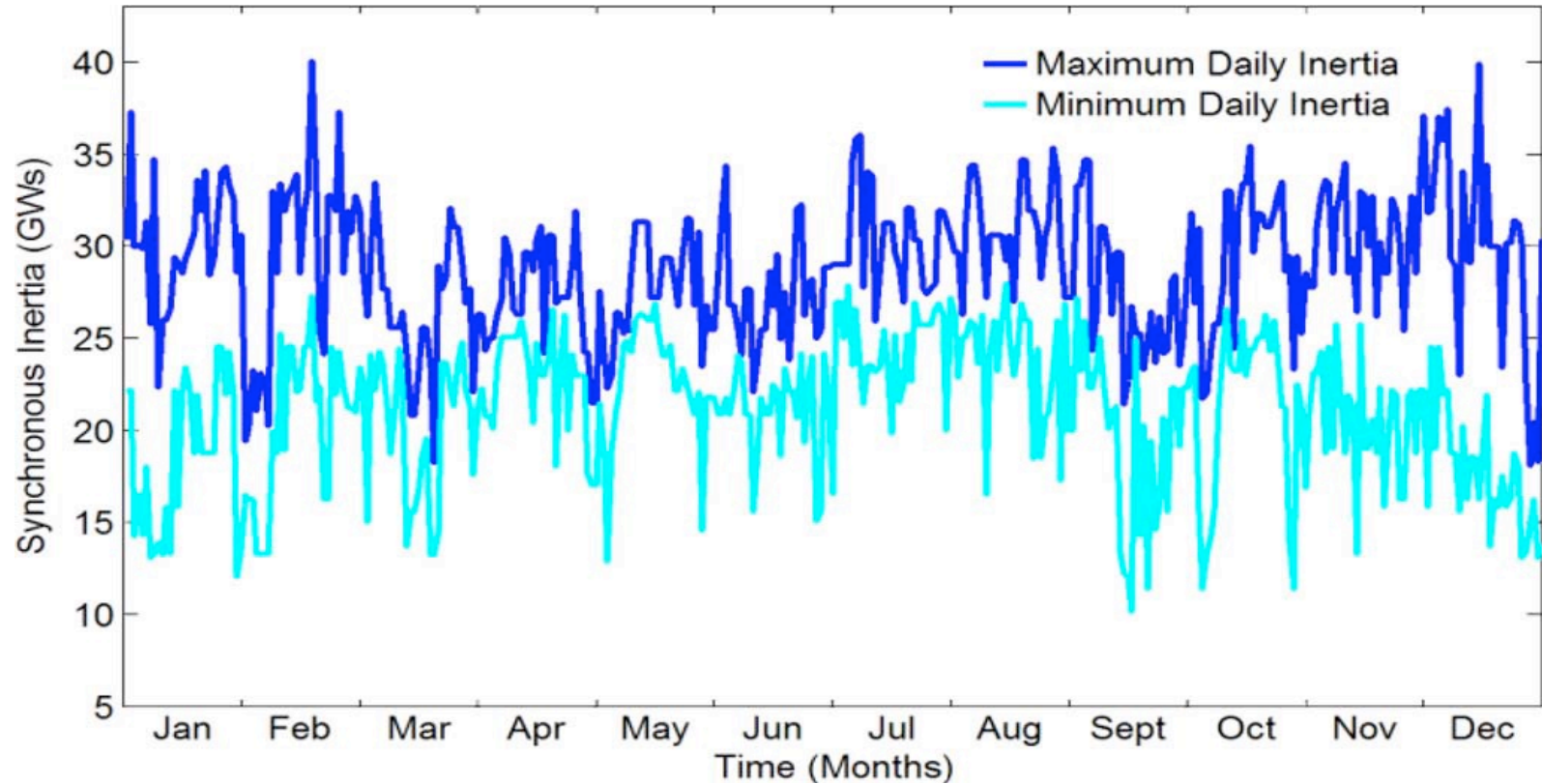

Loadflow Assessment



- Modified unit commitment / economic dispatch
 - Incorporation of *must run* and *locational* plant constraints?
 - Inclusion of DC network + assessment of N-1 security?
- Network expansion / reinforcement
 - Dynamic line rating + High temperature low sag conductors
 - Power flow controllers / line compensation
 - SVC / STATCOM / FACTS devices / ...
- Probabilistic assessment of event occurrence and consideration of severity of outcomes
 - Time series loadflow – switching operations

Dynamic Modelling



- Increasing array of (bespoke) PE control structures
 - Modelling assumptions + Grid code compliance?
 - Utilisation of generic wind / PV models
- Offshore HVDC connected wind
 - Power control and system frequency support \Rightarrow represent HVDC controls, individual turbine controls and overall plant controller
- Assess existing (conventional) generator models
- Assess (regional) dynamic load models
- Inclusion of protection devices ... potentially larger frequency & voltage variations

Dynamic Load Models

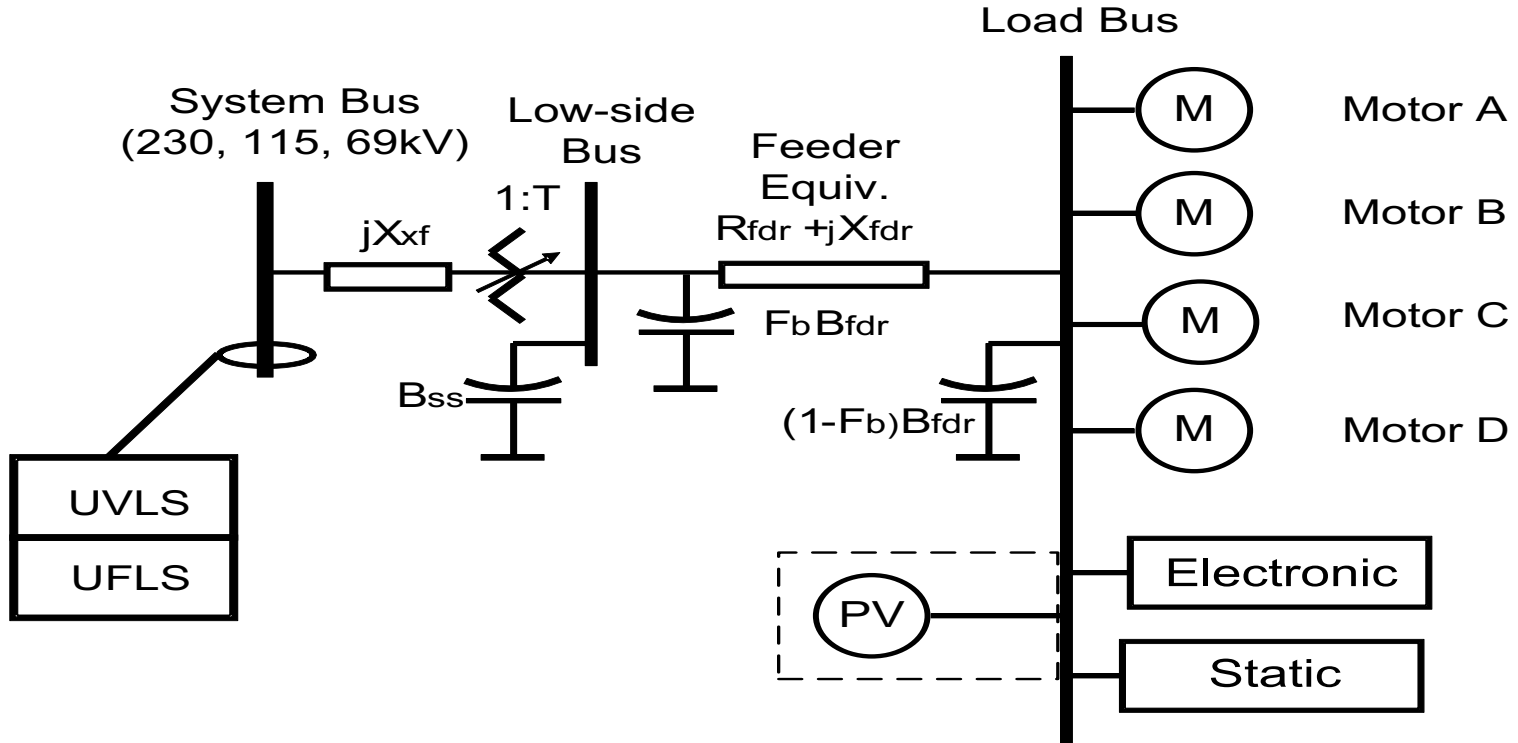

WWSIS– 3 - Midway-Vincent Fault

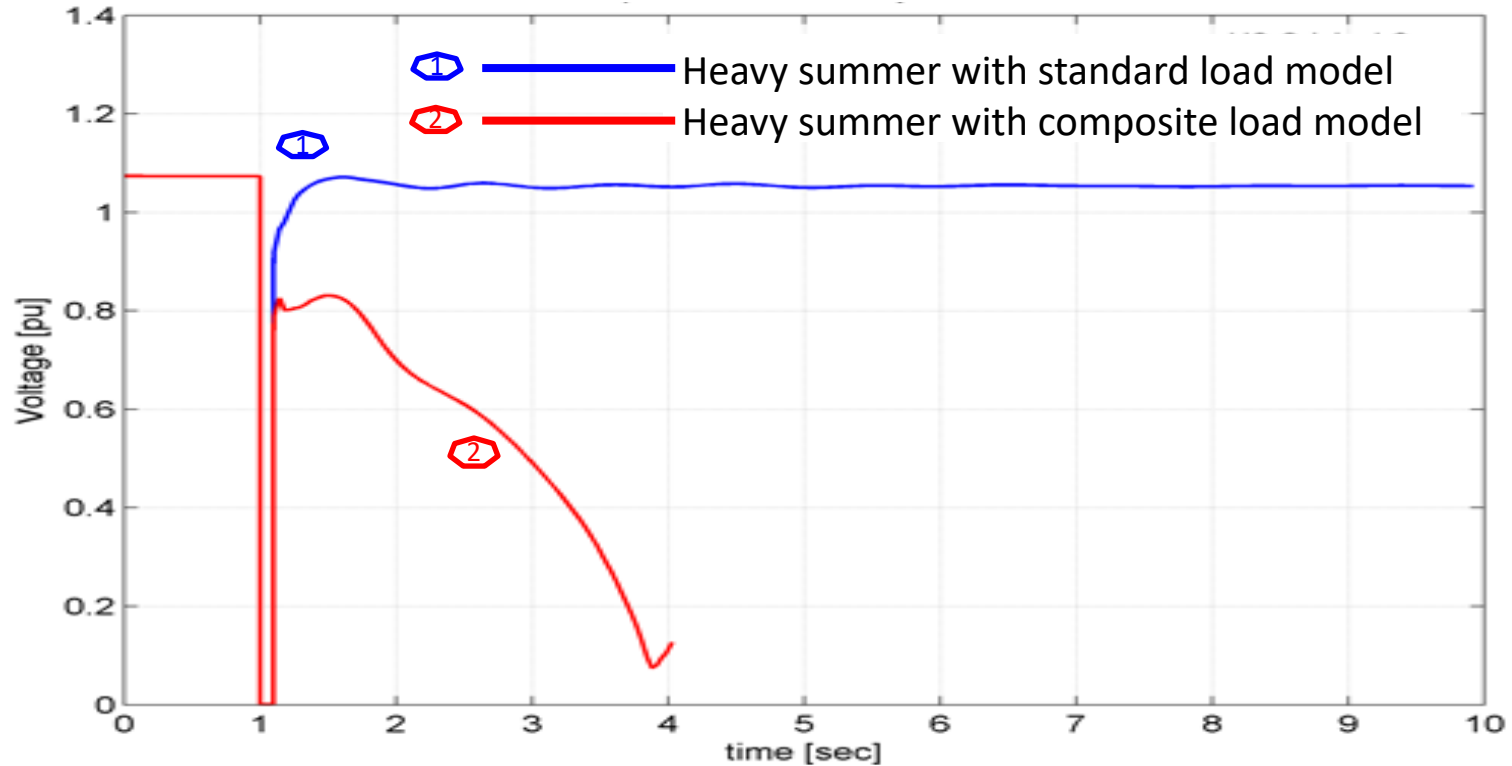

Generic Wind / PV Models

- WECC and IEC models capture minimum performance required by most grid codes for basic wind turbine types
- PV models based on type 4 wind plant models

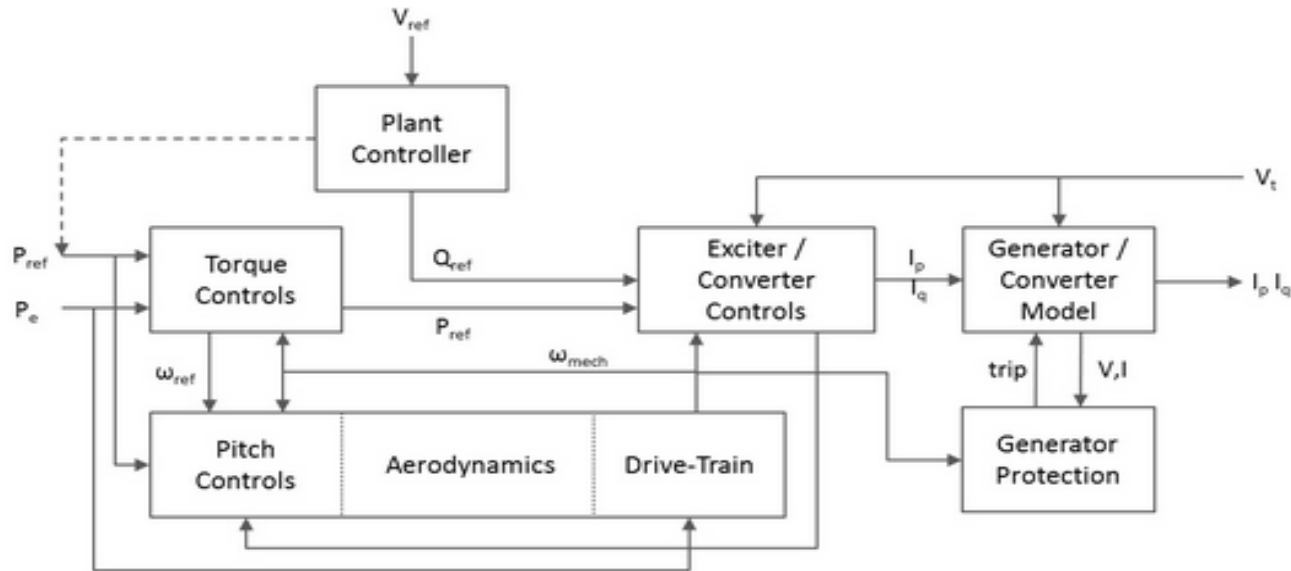

Evolving Wind / PV Plant Controls

- Plant models should be linked with evolving wind / PV capabilities and grid codes
- Fault ride through requirements
 - emphasis placed on MW or MVAr response?
- Fast frequency (emulated inertia) response
- High wind ride through ...

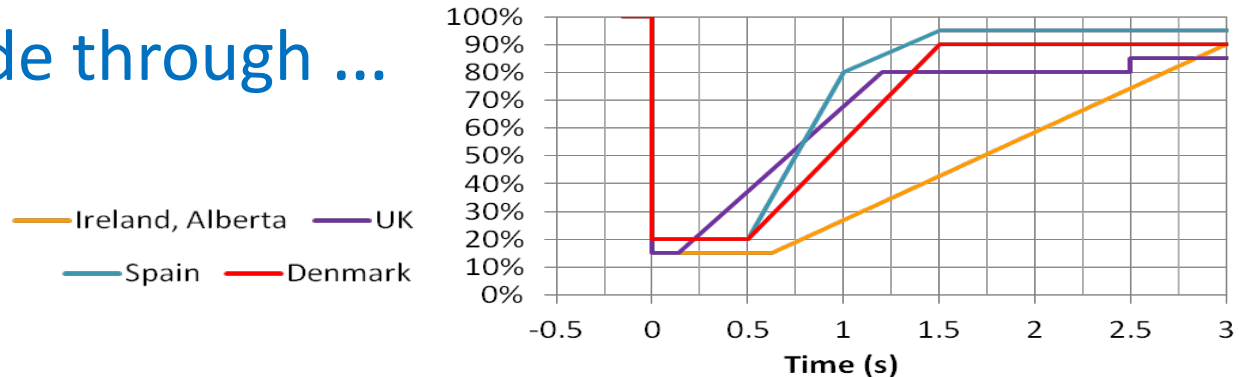

Wind Turbine Controls



High Wind Shutdown

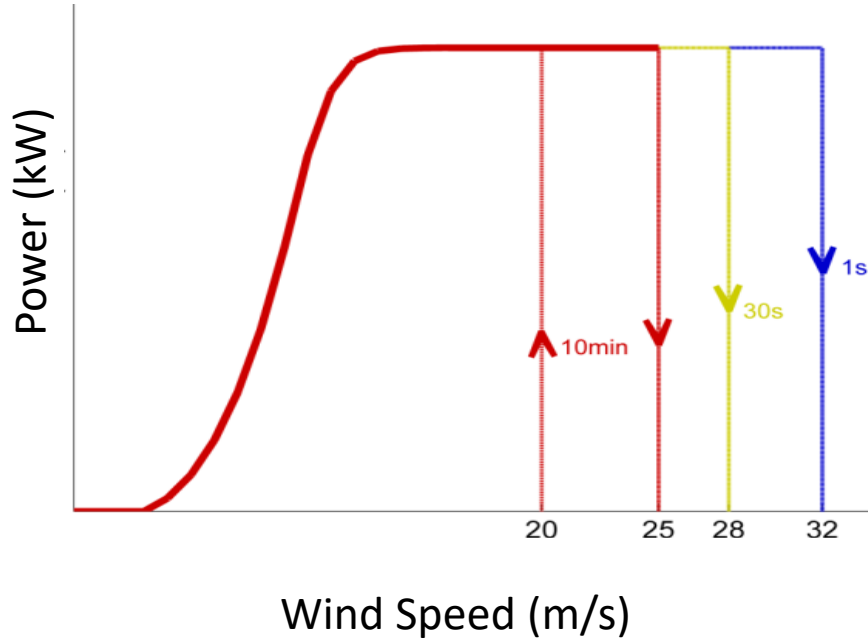

High Wind Ride Through

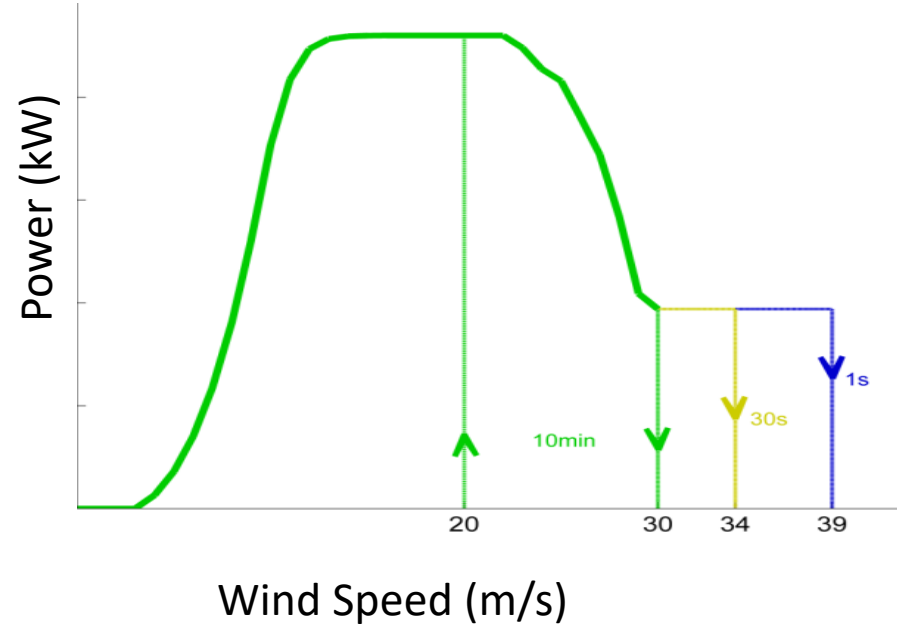

Horns Rev 2 – 30th January 2013

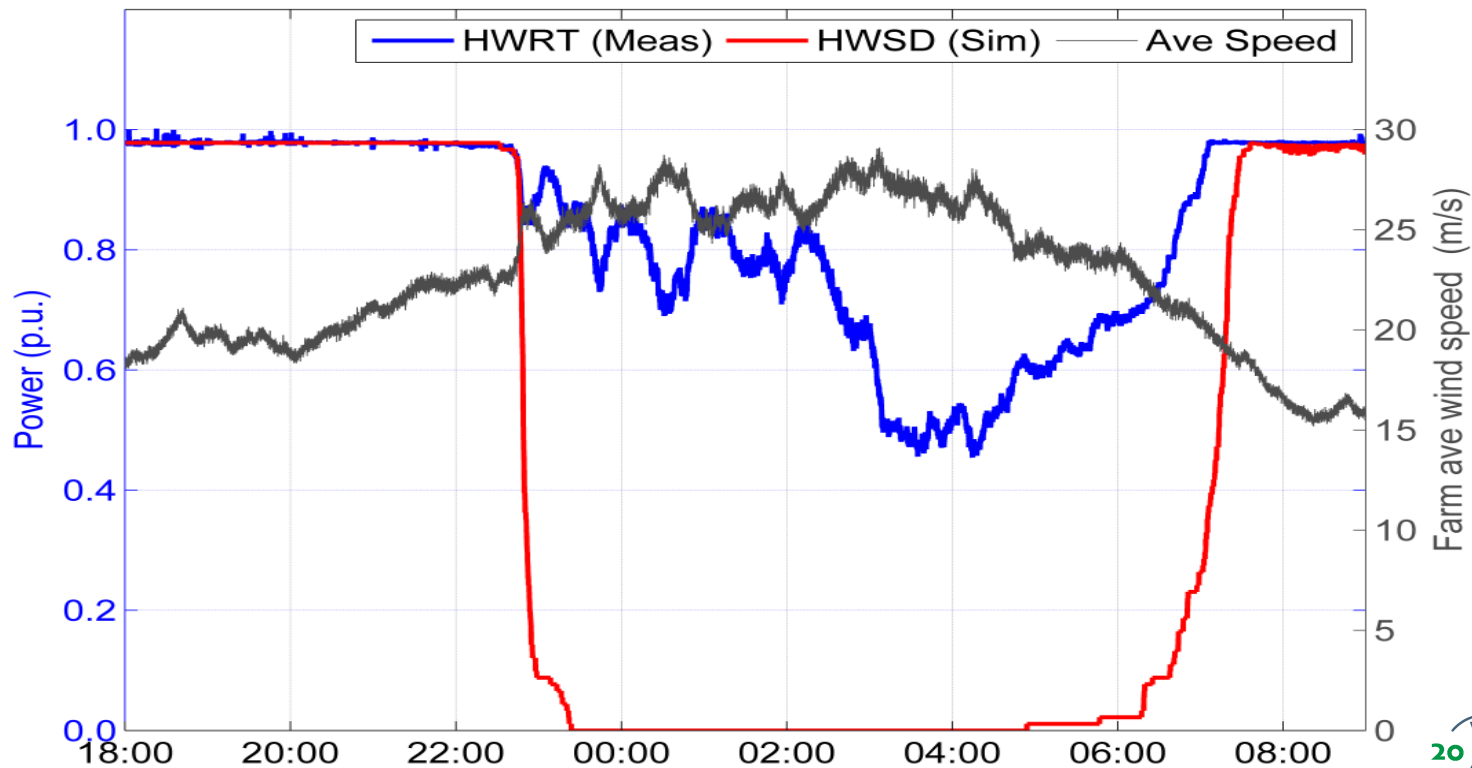

Demand / Storage Response

- Configurable under / over response curves
- Configurable reserve / recovery curves

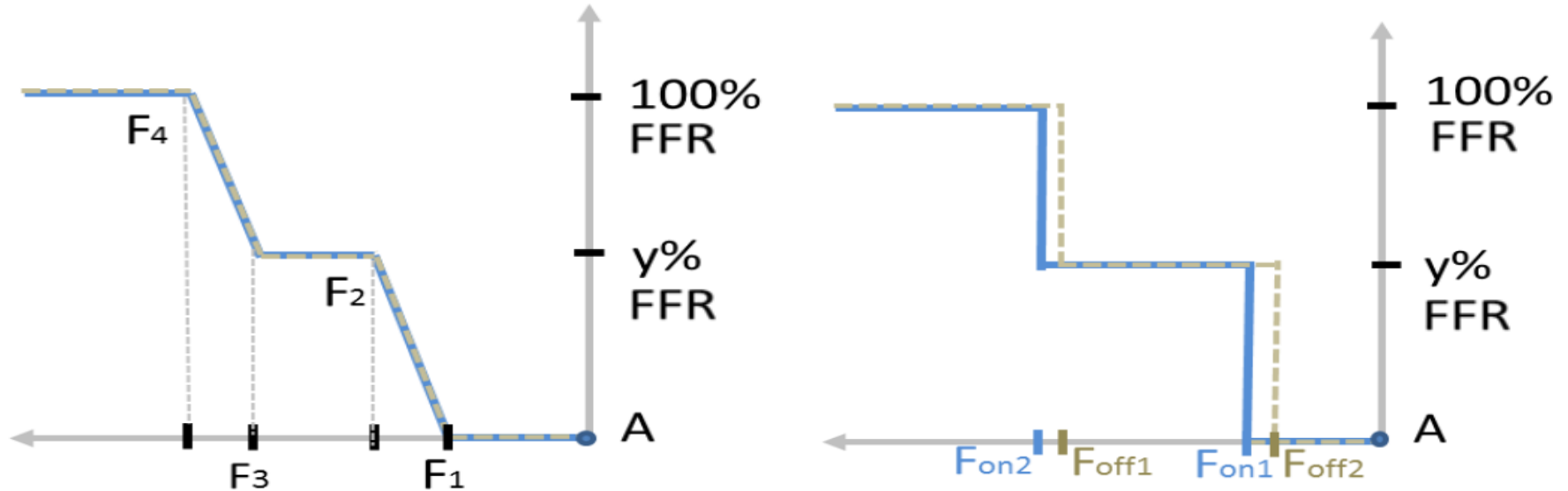

FFR – Fast frequency response

Stability Analysis – Additional Options

- Distribution of generation across network
- Voltage dip induced frequency dips
- Sympathy (distribution) tripping due to transmission-level events
 - Voltage trip vs. voltage ride through settings
- Sub-synchronous interactions
 - Sub-synchronous resonance, sub-synchronous torsional interactions and sub-synchronous control interactions

Voltage Dip-Induced Frequency Dips

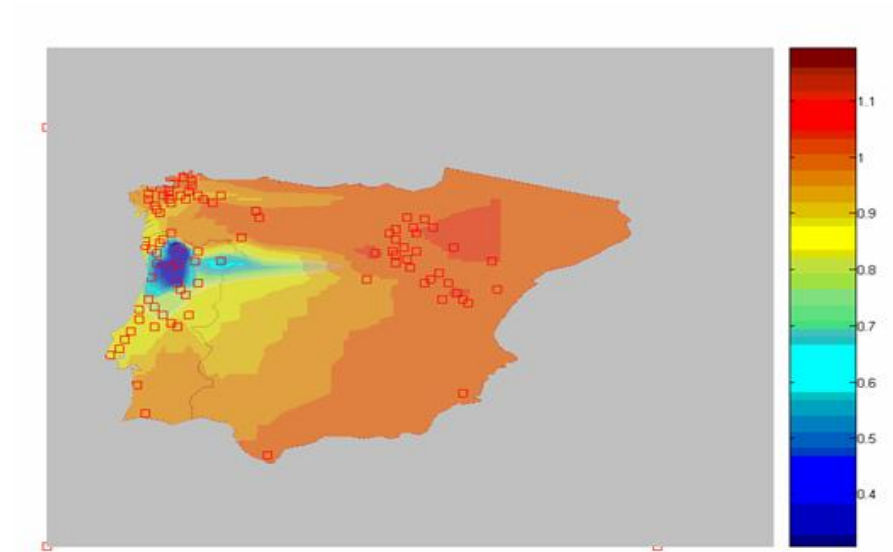
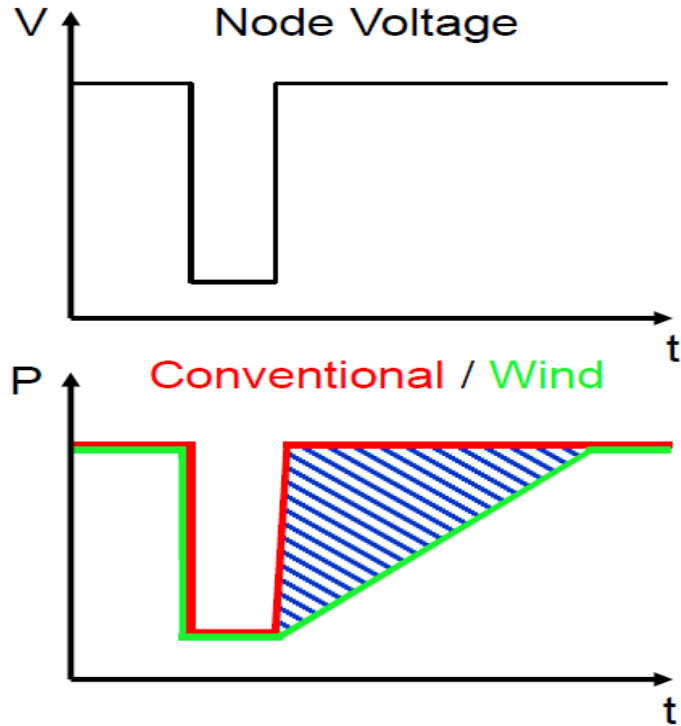

Voltage Dip-Induced Frequency Dips

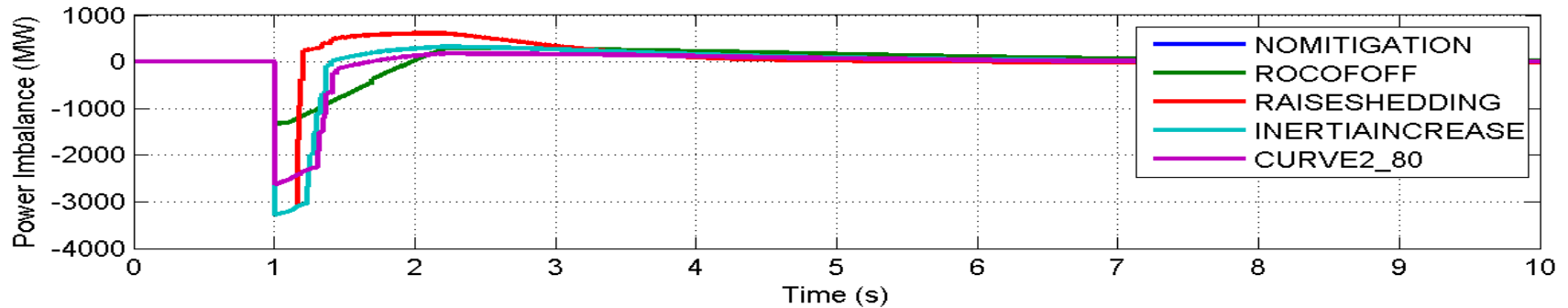
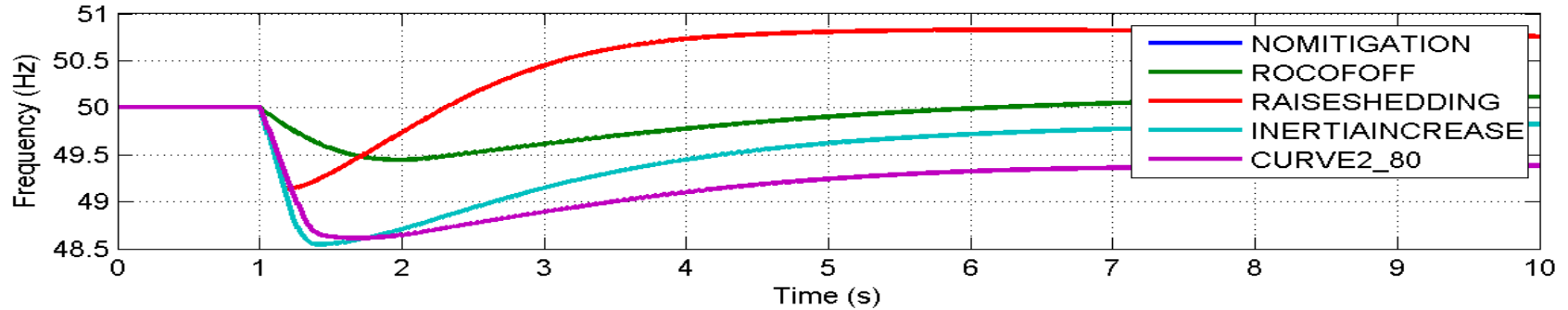

System Modelling Analysis – 3 ϕ Fault

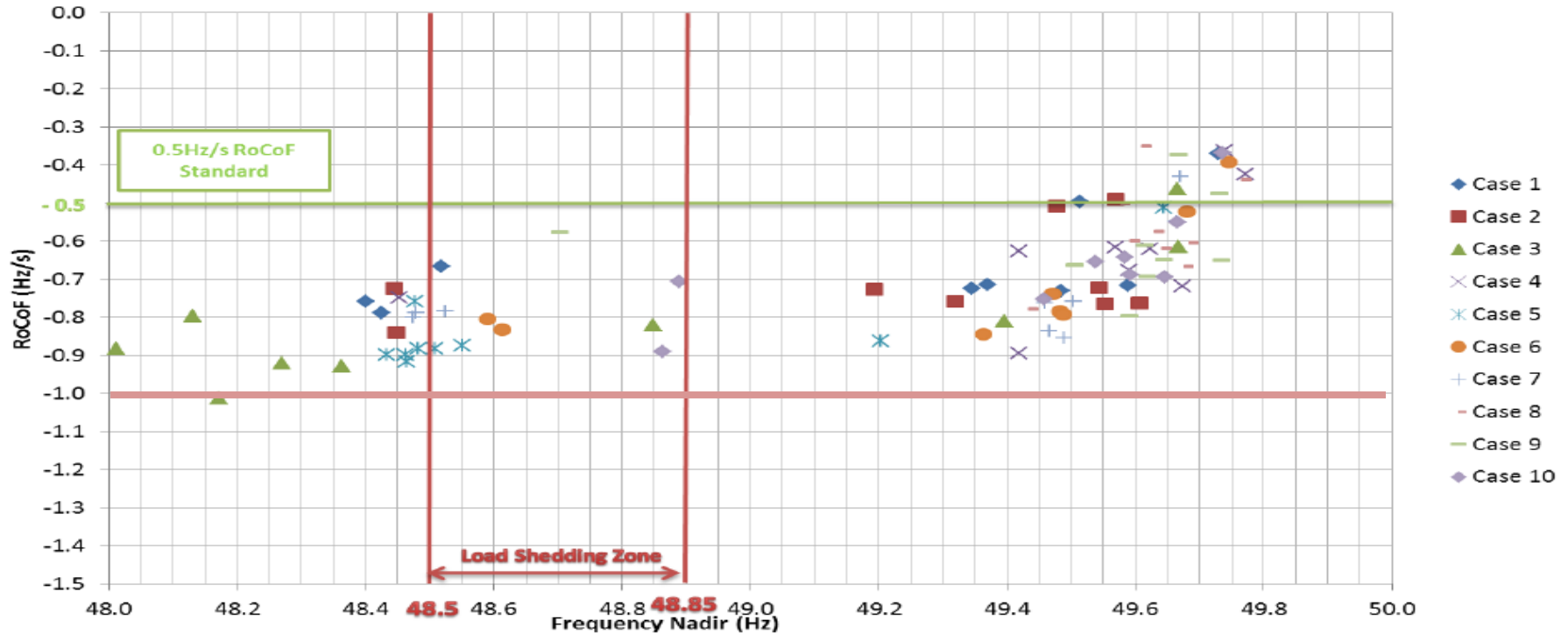

Enhanced Distribution Network Model

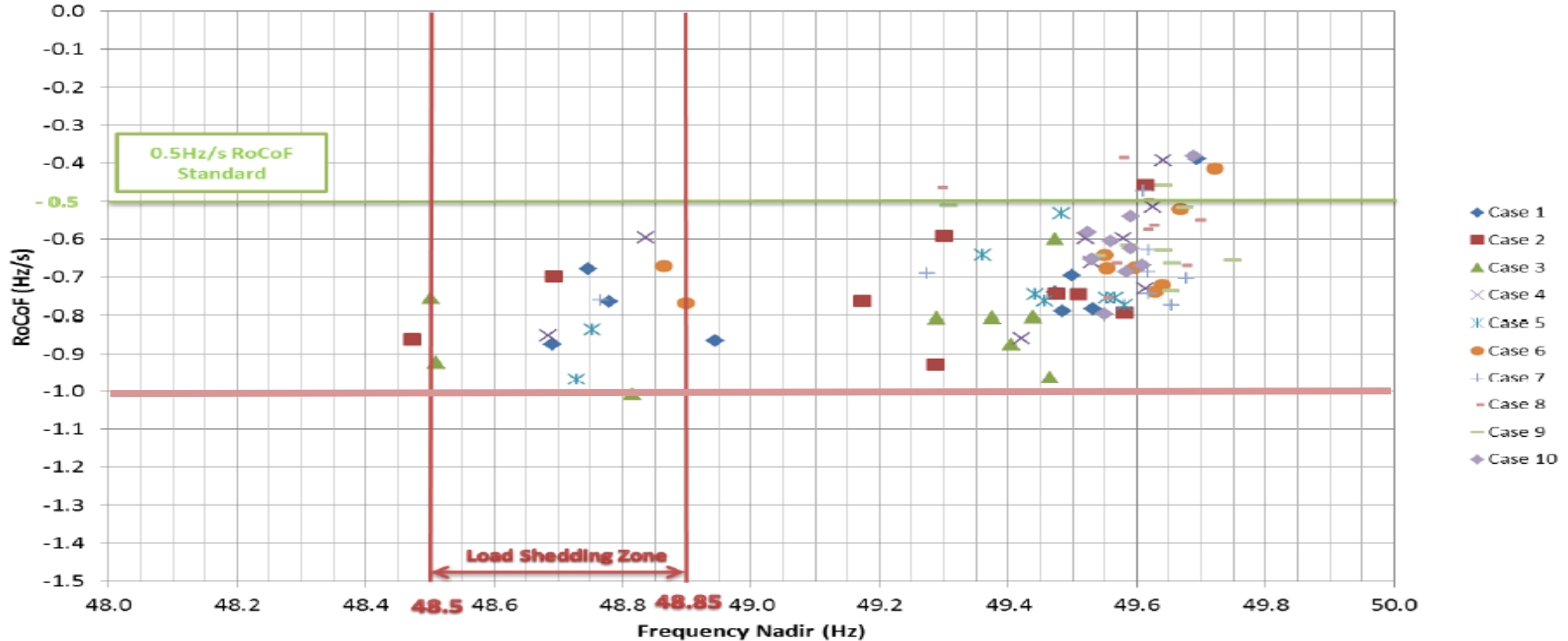

Concluding Comments

- Trade-off with transmission planning and operational policies requires multiple studies
- At higher wind / PV shares, stability issues can take precedence over UC / flexibility / market issues / ...
- Accurate assessment requires validated wind turbine / PV / load / generator models + proposal of control strategies
- Relative importance of voltage / transient / small-signal / frequency stability issues can be system dependent
 - Network topology, underlying plant portfolio including renewables, e.g. solar, wind turbine types + location, grid code requirements
 - Studies should evolve from "what are my problems?" to "how can I take advantage of my new control options?"



Distribution integration studies

Contributors: B. Mather (NREL), M. Kraiczy, C. Ma, M. Braun (Fraunhofer IEE) and S. Meinecke (University of Kassel)



Distribution grid

Distribution grid modelling

- **Challenge:** Scarce input data, high complexity and regional diversity of distribution level
- Example - Grid modelling in state-wide/ system-wide distribution integration studies:
 1. Analysis of representative grids in detail, i.e. via clustering/ taxonomy
 2. Automated (simplified) analysis techniques, possibly with assumptions of simplified distribution grid data

→ Reduce complexity of distribution level, but preserve diversity and relevant characteristics of distribution level
- Best-practice of distribution grid modelling depends on detailed study objective and available input data.

Data acquisition, data handling and distribution grid modelling is still a major challenge for distribution integration studies. For comprehensive system-wide distribution grid studies, a high degree of automation for data handling and analysis is required.



Distribution grid

Objectives of distribution integration studies

- DER integration and other impact factors (e.g. digitalization) are main drivers for the development of new planning procedures and tools in the distribution level
- Selected objectives of distribution integration studies:
 - Hosting capacity analysis
 - Distribution network reinforcement analysis
 - Voltage variability analysis and test of control algorithms
 - Grid losses analysis
- Further objectives, e.g.: protection and unintentional islanding studies, flicker and harmonics studies, development of dynamic DER and distribution grid equivalents and several more.



Distribution grid

Objectives of distribution integration studies

Hosting Capacity Analysis

- **Objective:**
 - Analyze the maximum amount of wind or PV interconnections on a existing networks without the need of any grid reinforcements.
 - Screening method for PV/wind interconnections
 - Benchmark of mitigation methods to avoid grid reinforcements
- **Example - Deployment scenario independent hosting capacity:**
 - Provides the maximum amount of wind/PV that can be integrated on a circuit regardless of where the wind/PV interconnects to the system
 - Valuable for distribution utilities and developers in the interconnection process of many wind/PV systems (e.g. residential roof-top PV)

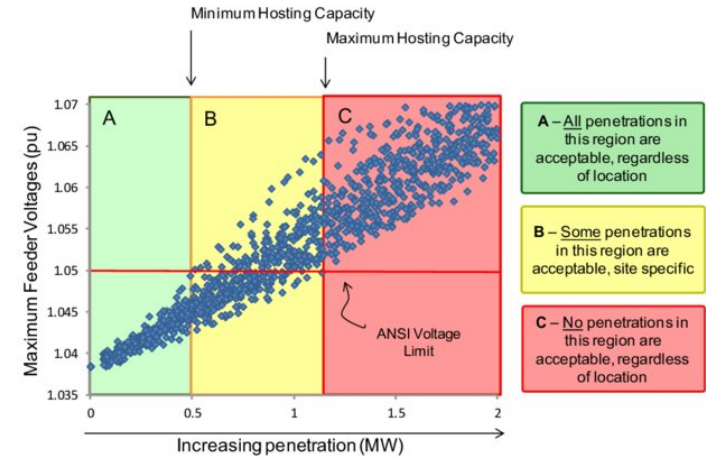

Fig: Example Calculation of Hosting Capacity (Source: Alternatives to the 15% Rule: Modeling and Hosting Capacity Analysis of 16 Feeders. EPRI, Palo Alto, CA: 2015. 3002005812)



Distribution grid

Objectives of distribution integration studies

Distribution grid reinforcement analysis

- **Objective:**
 - Estimate the DER grid integration costs in the distribution level
 - Benchmark of different grid integration measures
- **Best practice example/ recommendation:**
 - A comprehensive catalogue of grid planning measures should be considered, i.e. grid optimization before grid reinforcement before grid expansion (e.g. [1]).
 - Based on available input data and the scope of the study, the analyses can either be performed using representative or actual grid data.
 - Presentation of results: important to put the wind/PV integration driven reinforcement costs in contrast with generally necessary reinforcements, such as replacing outdated grid assets.

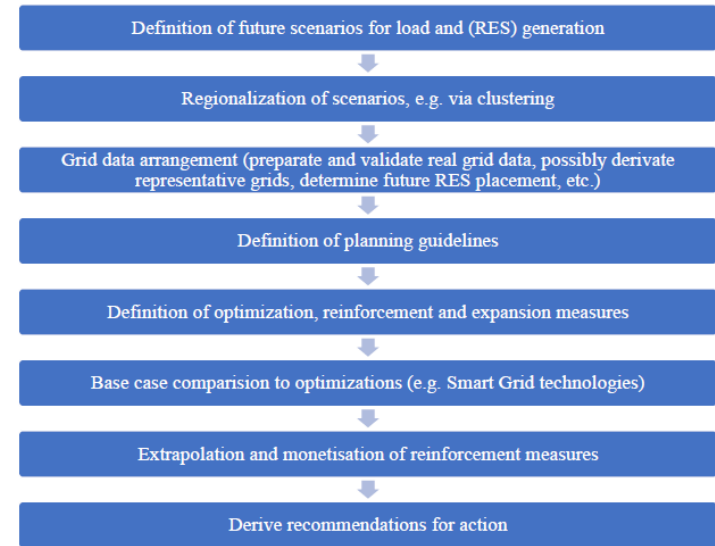

Fig.: Simplified flow chart for system-wide distribution grid reinforcement studies

Distribution grid

Summary distribution integration studies

■ Modelling and data handling

- Best-practice of distribution grid modelling depends on detailed study objective and available input data.
- Data acquisition, data handling and appropriate distribution grid modelling still a major challenge for distribution integration studies. For comprehensive state-wide and system-wide distribution grid studies, a high degree of automation for data handling is required.

■ Scope and Methodologies

- Scope, tools and methodologies for distribution integration studies will continue to expand and develop.
- Well established best-practice examples and advanced planning procedures for distributed Wind/PV integration studies partly still required.

■ Transmission-Distribution coordination

- Stronger coordination of transmission and distribution grid studies will be required with higher shares of wind/PV to access the full capabilities and flexibilities of distributed resources.



Analysing and Presenting the Results

- Iterations provide significant insights
- Comparisons to base case selected may impact results. Integration cost contradictory issue – so far no accurate methods found to extract system cost for a single technology
- Present the share of wind/PV for easier comparison with other studies

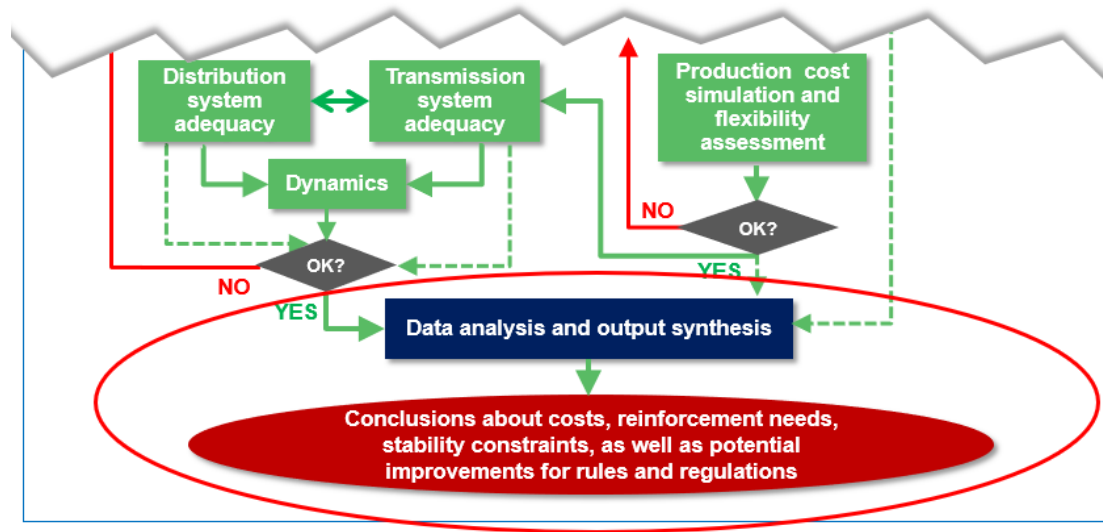

Future work: integration studies are still evolving, towards 100% renewable studies



- **Metrics and tools for flexibility needs** of the power system, and ways to achieve flexibility
- **Simulation tools that consider uncertainty** of wind in different time scales, and combine **network constraints with UCED constraints**
- Ways to set up simulation cases to efficiently extract impacts and system costs – **from cost of integration to cost of inflexibility**
- Stability issues with very high penetration cases. Future grids with more DC transmission.
- Implications of market design and/or regulatory processes for wind/PV integration.

Use the recommended practices check-list for benchmarking your study!

Link to report RP16 Ed.2 at Recommended Practices site: <https://community.ieawind.org/publications/rp>

Questions/experience in using the bullet point lists: hannele.holttinen@recognis.fi

Transmission part: damian.flynn@ucd.ie Distribution part: Markus.Kraiczky@iee.fraunhofer.de





IEA Wind Task 25

- Design and operation of power systems with large amounts of wind power
- 17 countries + Wind Europe participate



Country	Institution
Canada	Hydro Quebec (Alain Forcione, Nickie Menemenlis); NRCan (Thomas Levy)
China	SGERI (Wang Yaohua, Liu Jun)
Denmark	DTU (Nicolaos Cutululis); Energinet.dk (Antje Orths, Peter Börre Eriksen)
Finland (OA)	VTT (Hannele Holttinen, Juha Kiviluoma)
France	EdF R&D (E. Neau); TSO RTE (J-Y Bourmaud); Mines (G. Kariniotakis)
Germany	Fraunhofer IEE (J. Dobschinski); FfE (S. von Roon); TSO Amprion (P. Tran)
Ireland	Energy Reform (J. Dillon, M. O'Malley); UCD (D. Flynn); SEAL (J. McCann)
Italy	TSO Terna Rete Italia (Enrico Maria Carlini)
Japan	Tokyo Uni (J. Kondoh); Kyoto Uni (Y. Yasuda); CRIEPI (R. Tanabe)
Mexico	INEEL (Rafael Castellanos Bustamante, Miguel Ramirez Gonzalez)
Netherlands	TU Delft (Simon Watson)
Norway	NTNU (Magnus Korpås); SINTEF (John Olav Tande, Til Kristian Vrana)
Portugal	LNEG (Ana Estanquero); INESC-Porto (Ricardo Bessa)
Spain	University of Castilla La Mancha (Emilio Gomez Lazaro)
Sweden	KTH (Lennart Söder)
UK	Imperial College (Goran Strbac); Strathclyde Uni (Olimpo Anaya-Lara)
USA	NREL (Bri-Mathias Hodge); UVIG (J.C. Smith); DoE (Charlton Clark)
Wind Europe	European Wind Energy Association (Ivan Pineda, Daniel Fraile)