

## 1. FUNCTION

See figure 1 for general arrangement of the valve.

- 1.1 Valve is designed for the inflation and deflation of any flexible pneumatic structure within the limits given by the clamping performance (see section 3)
- 1.2 To inflate the structure an adapter which fits tightly in the throat of the valve is needed. Leaffield Marine supply a range of such adapters; the same adapter can be used on all the valves in the comprehensive Leaffield range.
- 1.3 With the spindle in its normal (i.e raised) position the valve acts as a non-return valve which is opened by the inflation pressure. The low back pressure during inflation allows the use of manual pumps or electrical pumps/blowers.
- 1.4 To deflate, the spindle can be depressed and either held down to adjust the pressure or rotated clockwise to lock "open" if a full deflation is required.
- 1.5 Once inflation is complete the cap should be fitted, this will prevent the contamination of the valve core assembly and inadvertent release. It also gives a smooth, snag free surface which reduces the possibility of damage to equipment or injury to passengers.
- 1.6 If the gas is not air, nitrogen, carbon dioxide (or a mixture of these), Leaffield Marine must be consulted.

## 2. FACTORY INSTALLATION

- 2.1 The valve can be clamped to structures with a fabric thickness 0.5 to 3.5mm.
- 2.2 Fabric hole diameter 32.5/33.5mm.
- 2.3 A 'Doubler' is generally recommended around the hole, ideally fitted to the inside, to reduce stress in the hole area.
- 2.4 If leakage occurs when the valve is installed.  
See figure 2 for suggested solutions.
- 2.5 The valve must only be fitted using the special tools supplied by Leaffield Marine. These are: Part No.C16603 for use on the outside of the buoyancy this will accept a 1/2" square drive.  
Part No. B16604 is the nest for holding the interior nut, its body is 65 A/F hexagon which can be held by any convenient method.
- 2.6 The recommended fitting torque is 27N.m (20lb.ft) when the installation is as shown in figure 2. For other arrangements Leaffield Marine should be consulted.
- 2.7 During assembly the User must not expose the valve to any substance which will degrade it The materials used for the valve components are shown on figure 1. Care should be taken to avoid contamination of the valve by adhesives or solvents during manufacture as this may degrade the valve performance.
- 2.8 Each valve should be re-torqued to 27N.m after at least 24 hrs have elapsed since the first tightening, this reduces the effect of creep in the clamped assembly during the service life. The second torquing can be carried out with the tube inflated. With some combinations of fabric and doublers it may be possible to achieve satisfactory, long-term, clamping with a single torquing.

## 3. PERFORMANCE

- 3.1 The preferred installations are shown in Figure 2. When single sided coated fabric is used Leaffield Marine should be contacted for advice.
- 3.2 In normal use the valve clamping can withstand a typical fabric hoop load of 15N/mm (86 lbf/in). This is the proof load and the maximum working load must be set by deciding a safety factor which should be at least 2, see graph below.
- 3.3 If the tube is less than 150mm (6ins) the assembly should be tested. If a valve is to be fitted where hoop loads are greater than 7.5N/mm - please contact Leaffield Marine for advice.
- 3.5 Each non-return valve seal is tested for leakage, the maximum acceptance rate is 15cc/hr of free air at a test pressure of 7KPa (1.0psig).
- 3.6 The cap seals against the housing to give a secondary sealing method in case of damage or degradation affecting the non-return valve.

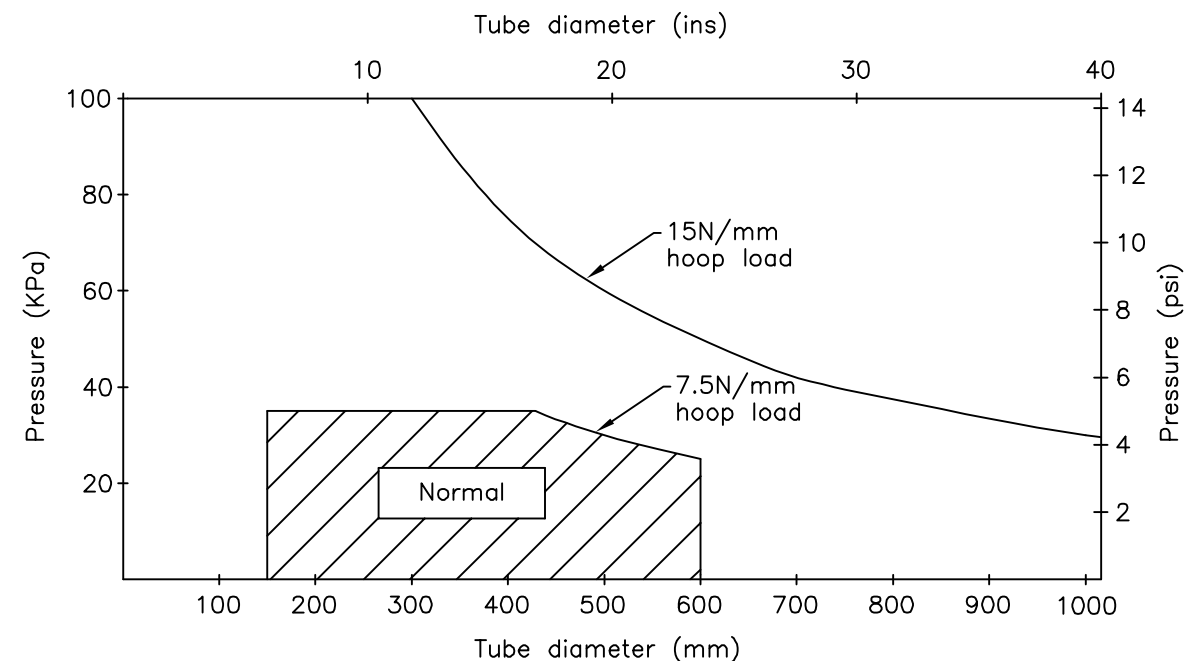

## 4. SERVICING

- 4.1 The valve needs minimum maintenance. It should be kept clean by using household detergent solution. Solvent cleaners should not be used.
- 4.2 For further information please refer to the service sheet.

## 5. STORAGE

- 5.1 For long term storage the valve must be stored away from dirt & solvent contamination.
- 5.2 When stored in acceptable conditions the storage period before installation should not exceed 5 years.

## 6. REPLACEABLE ITEMS

Refer to Figure 1.

Core Assembly  
Cap Assembly  
Cap seal

Leaffield Marine do not accept responsibility for the incorrect installation or use of their products. If there is any doubt about the suitability of the valve for its intended use please contact Leaffield Marine for advice.

APPR'D

CHECKED

DRAWN

SRS

© LEAFIELD MARINE LIMITED 1999  
This drawing is protected by Copyright and the information contained therein is the property of LEAFIELD MARINE LTD.  
The drawing may not be copied and the information contained therein may not be used or disclosed except with the written permission of and in the manner permitted by LEAFIELD MARINE LTD.

			LEAFIELD ENGINEERING LIMITED LEAFIELD CORSHAM WILTSHIRE	DIMNs. IN mm	SCALE NTS
	03	04/OCT/05	C7 VALVE INSTALLATION AND SERVICE INSTRUCTIONS	DRAWING No.	SHT 1 OF 3
M2463	B	14.9.99			
	A	29.5.98			
CHANGE	ISSUE	DATE		16623	

FIGURE 1

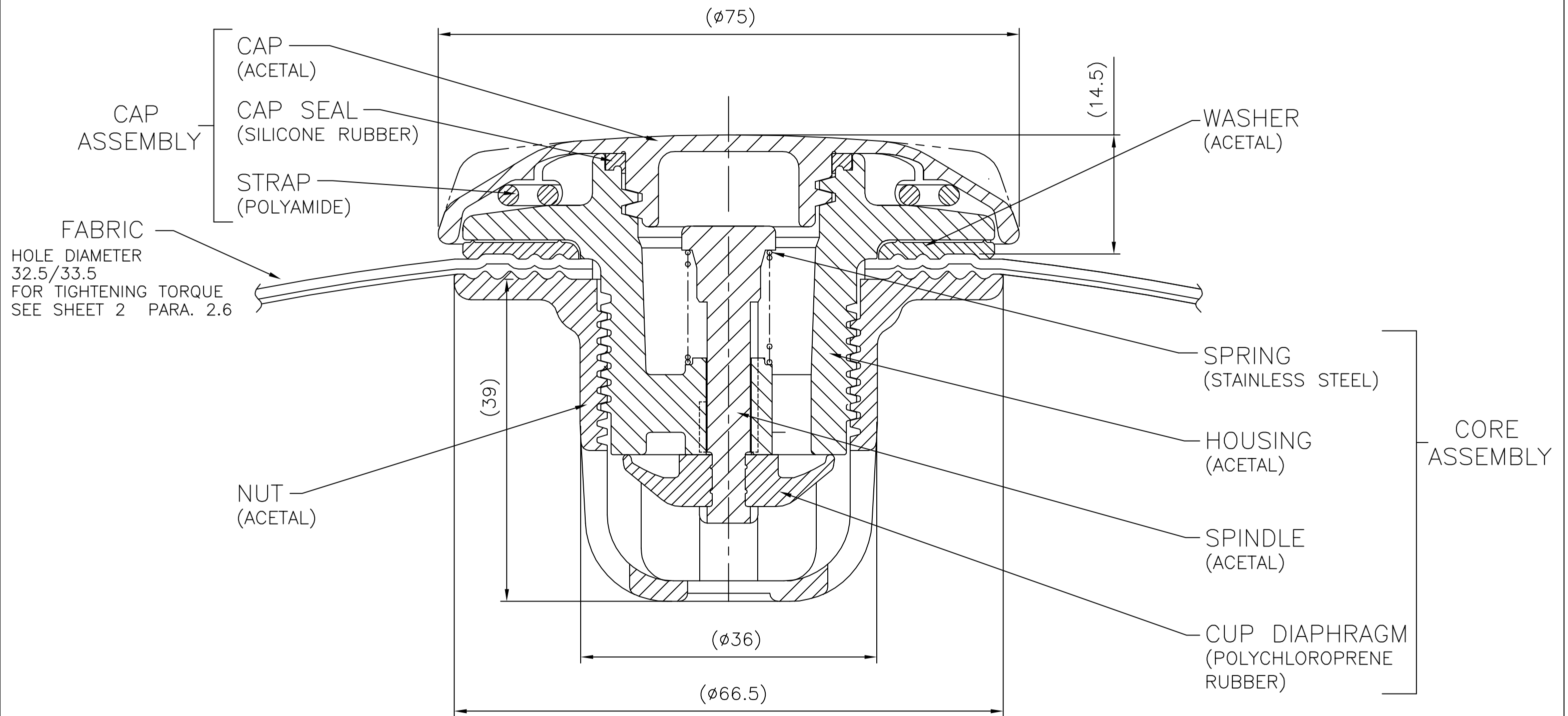

APPR'D
CHECKED
DRAWN
SRS

© LEAFIELD MARINE LIMITED 1999  
 This drawing is protected by Copyright and the information contained therein is the property of LEAFIELD MARINE LTD.  
 The drawing may not be copied and the information contained therein may not be used or disclosed except with the written permission of and in the manner permitted by LEAFIELD MARINE LTD.

	03	04/OCT/05
M2463	B	14.9.99
	A	29.5.98
CHANGE	ISSUE	DATE

LEAFIELD ENGINEERING LIMITED  
 LEAFIELD CORSHAM WILTSHIRE

**C7 VALVE  
 INSTALLATION AND SERVICE  
 INSTRUCTIONS**

DIMNs. IN mm	SCALE 2:1
DRAWING No.	
16623	SHT 2 OF 3

A

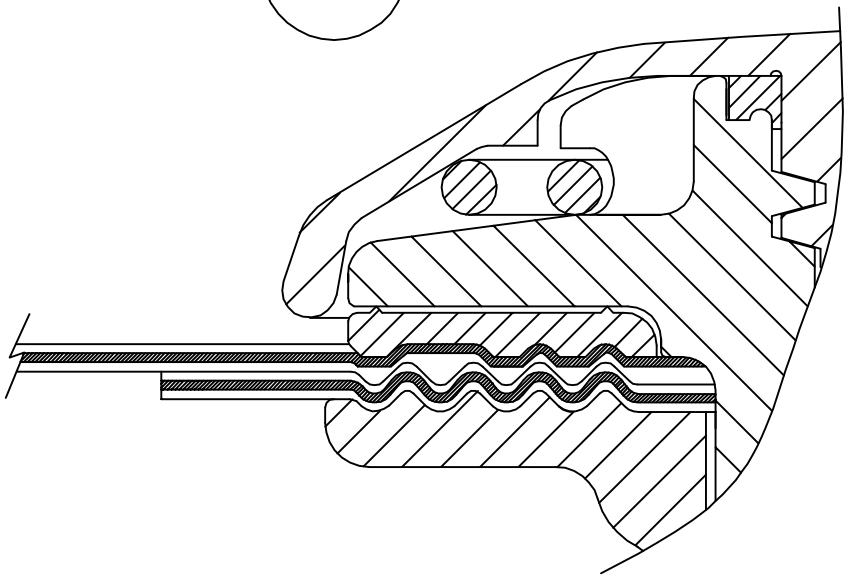

FABRIC COATED ON BOTH SIDES.  
DOUBLER ON THE INSIDE.

B

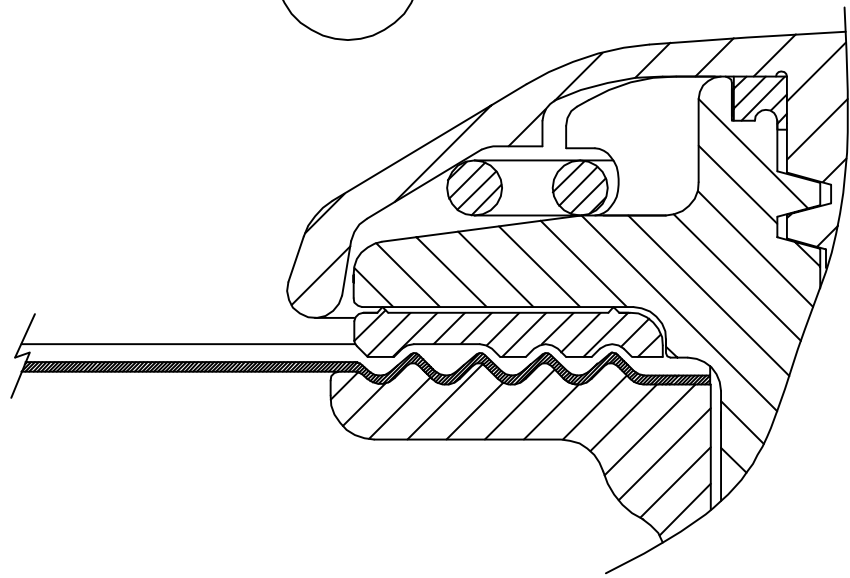

FABRIC COATED ON OUTSIDE.

C

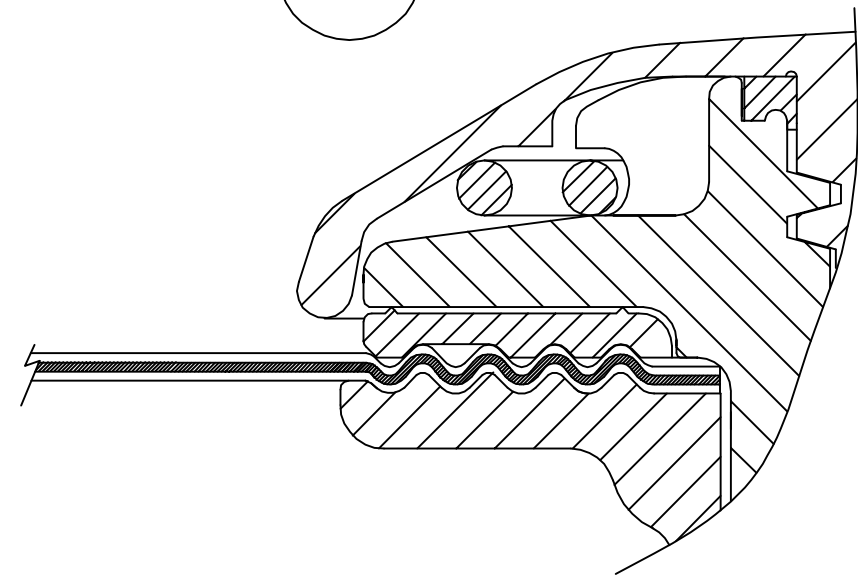

FABRIC COATED ON BOTH SIDES.

APPR'D
CHECKED
DRAWN
SRS

UK telephone no. 01225 810771  
International telephone no. 44 1225 810771  
email:valves@leafield.co.uk

© LEAFIELD MARINE LIMITED 1999  
This drawing is protected by Copyright and the information contained therein is the property of LEAFIELD MARINE LTD.  
The drawing may not be copied and the information contained therein may not be used or disclosed except with the written permission of and in the manner permitted by LEAFIELD MARINE LTD.

	03	04/OCT/05
M2463	B	14.9.99
	A	29.5.98
CHANGE	ISSUE	DATE

LEAFIELD ENGINEERING LIMITED  
LEAFIELD CORSHAM WILTSHIRE

C7 VALVE  
INSTALLATION AND SERVICE  
INSTRUCTIONS

DIMNs. IN mm	SCALE 2:1
DRAWING No.	
16623	SHT 3 OF 3