

REVISIONI			
ZONA	REV.	DESCRIZIONE	DATA

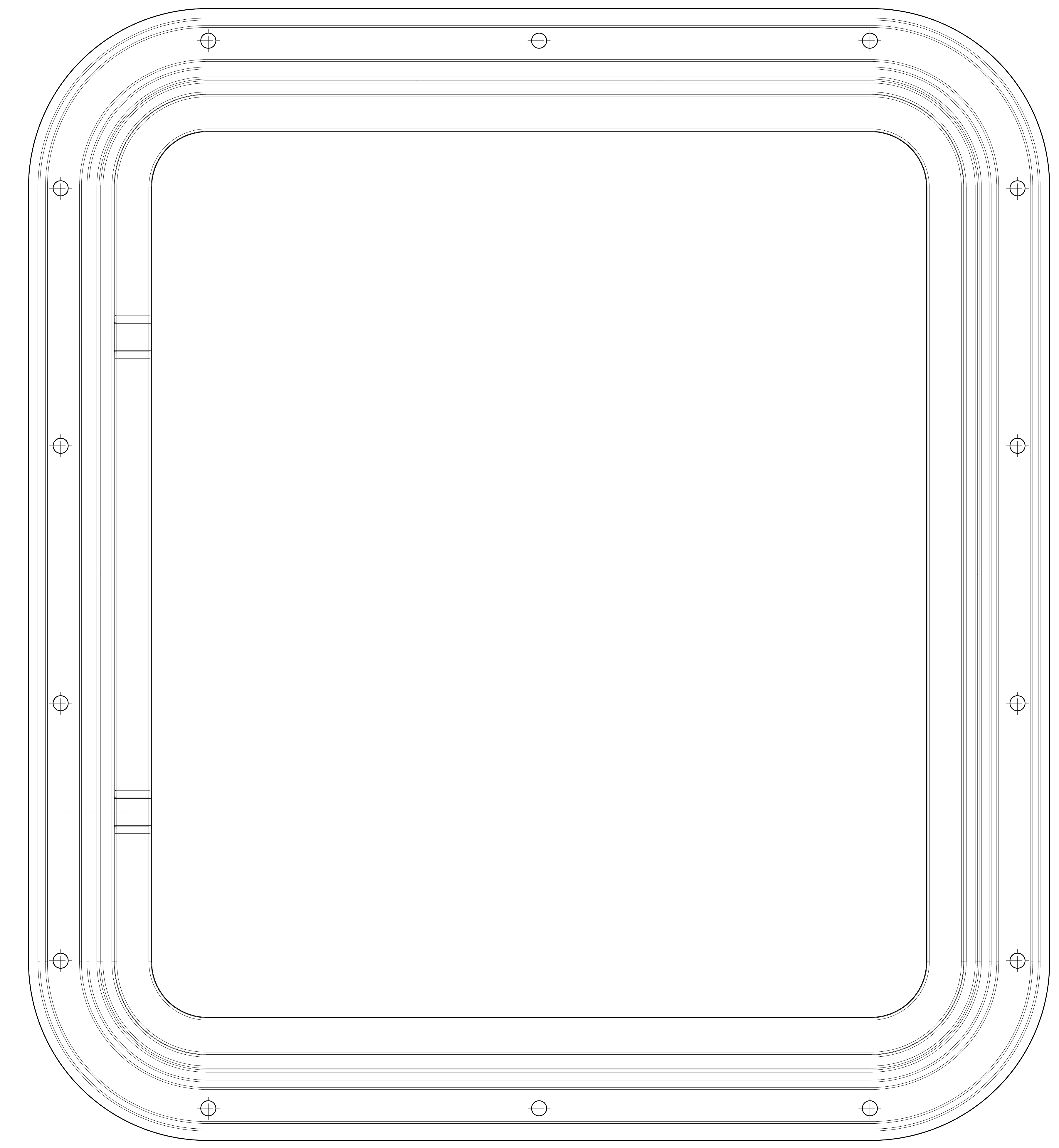

Sezione A-A

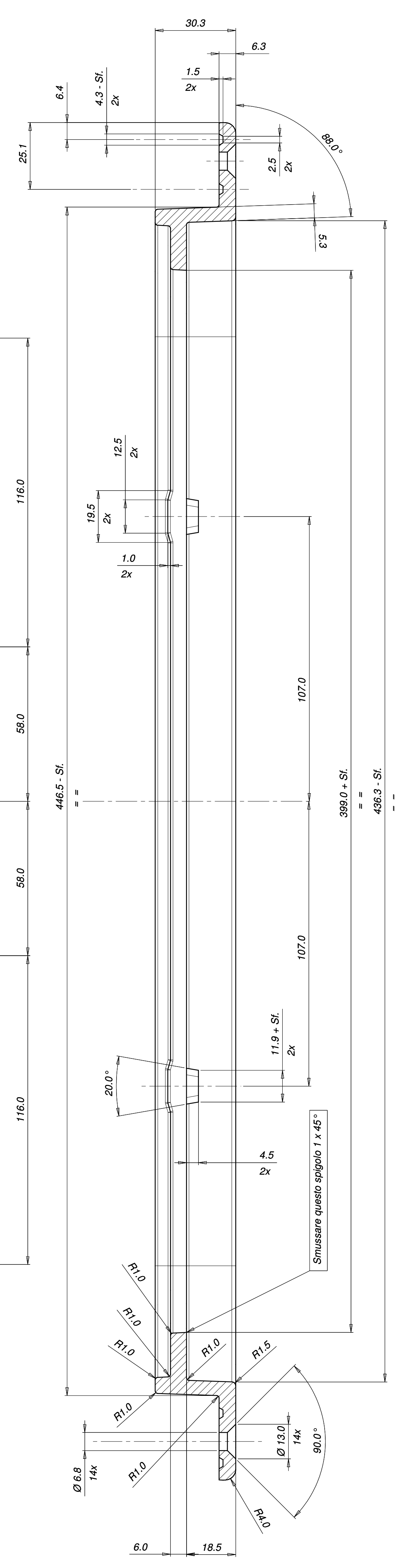
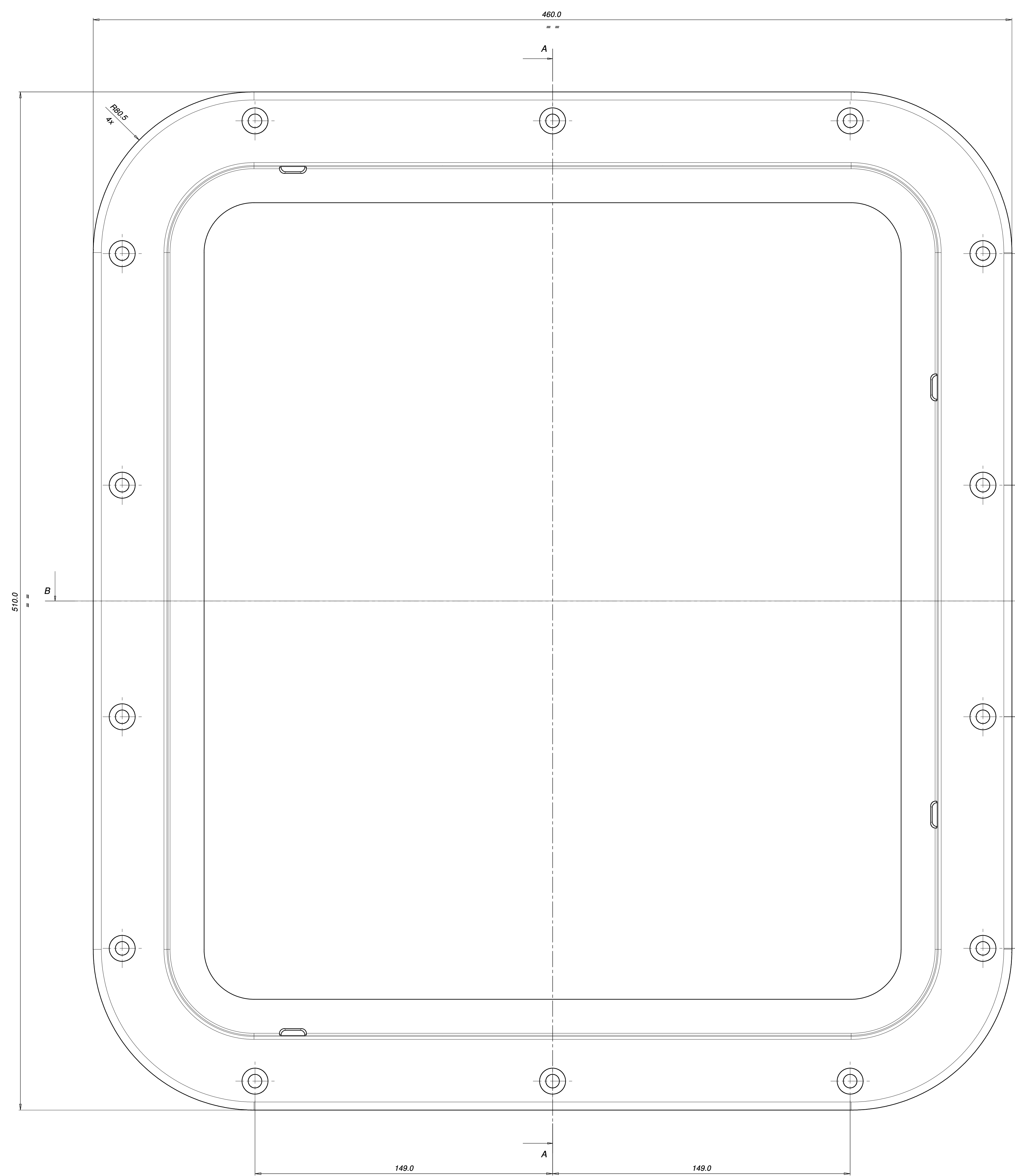
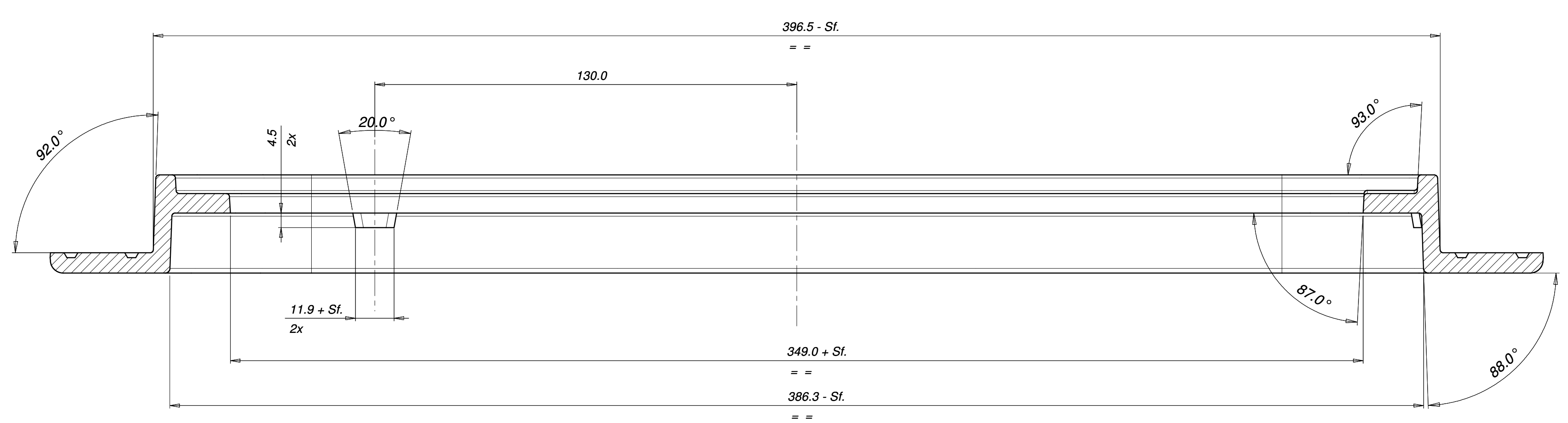

Sezione B-B

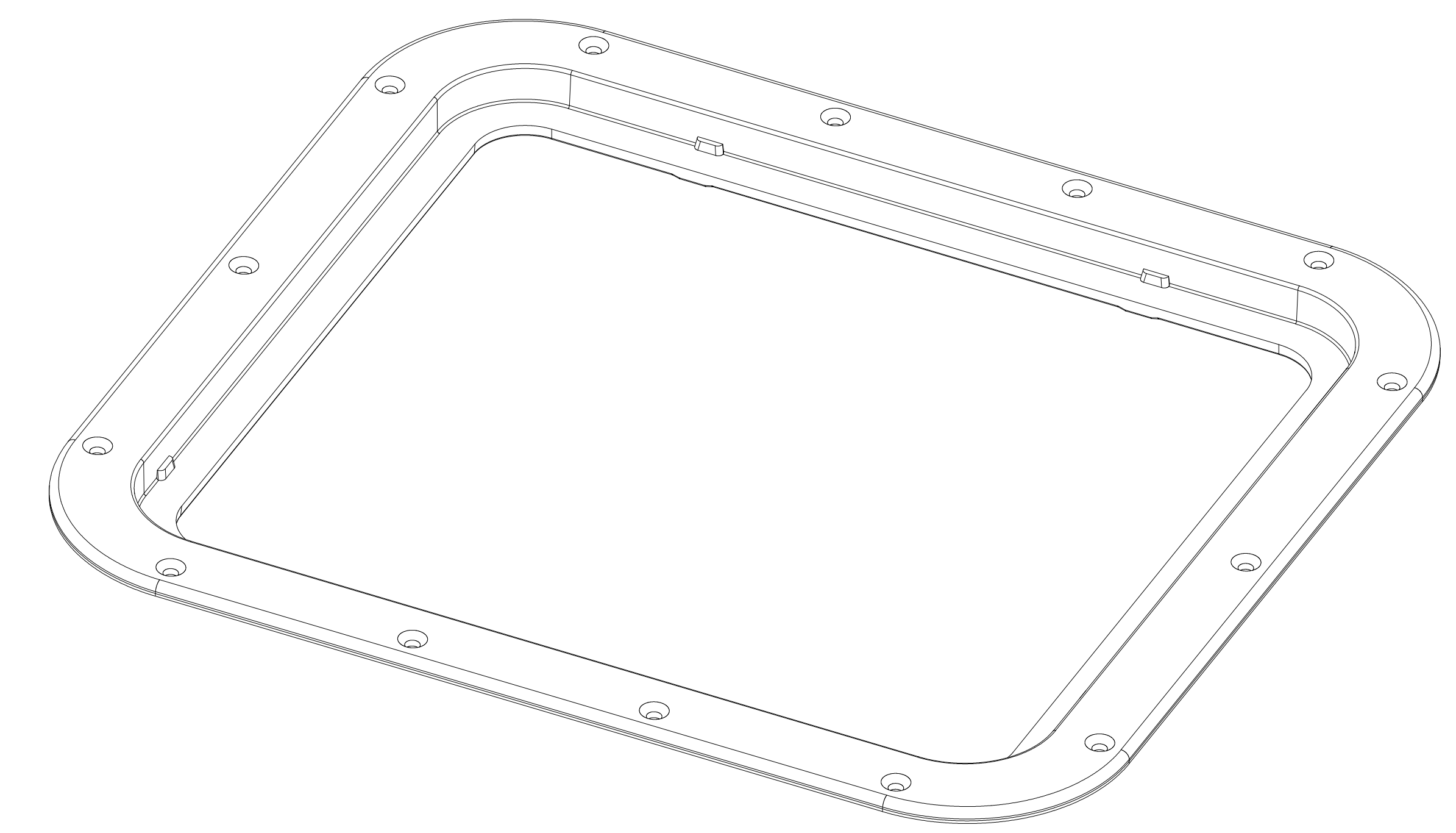

Scala 1:2

Ritiro non considerato

Per tutte le dimensioni non indicate vedere modello 3D

Data : 02/12/2014	CORNICE x PORTELLO n° 3 - (480x510)
Materiale : Alluminio	
Quantità :	
Trattamento : Verniciatura	
Formato : A0+	Codice : 982_09_Disegno
Scala : 1:1	Foglio 1 di 1

