



BINDER PAGES

2023



TABLE OF CONTENTS

01 DRIVERS

02 FAIRWAY

03 HYBRID

04 IRONS

05 WOMEN'S

06 WEDGES

07 PACKAGED SETS

08 GOLF BALL

09 ODYSSEY

10 CUSTOM LOGO

11 PERFORMANCE GEAR

12 CARRYOVER

01

DRIVERS

PARADYM



PARADYM DRIVER

The Paradym driver model provides a refined shape with high MOI and adjustable perimeter weighting. Engineered for players of all skill levels, this club promotes high launch and low spin characteristics along with a neutral ball flight. It's our best combination of distance, forgiveness, and adjustability.

THE NEW PARADYM IN PERFORMANCE

- ✓ **A PARADYM SHIFT IN DISTANCE FROM AN INDUSTRY-FIRST 360° CARBON CHASSIS**
360° Carbon Chassis promotes unprecedented weight redistribution for maximized distance. The Triaxial Carbon crown and Forged Carbon sole is 44% lighter than a titanium chassis. This massive weight savings is repositioned for higher MOI and increased forgiveness.
- ✓ **SPEED & STABILITY FROM NEW JAILBREAK A.I.**
Our new A.I. designed Jailbreak system provides stability in both the horizontal and torsional direction. Now with a 33% lighter weight design, we've enhanced stability for faster ball speeds from our industry-leading COR.
- ✓ **NEW A.I. DESIGNED FACE OPTIMIZED FOR DOWNRANGE DISPERSION**
An all-new A.I. face optimization enhances speed, launch and spin, and now downrange dispersion. This is the world's most advanced driver face designed by artificial intelligence.
- ✓ **INDUSTRY-LEADING FACE CUP AND FORGED TITANIUM FACE FOR FAST BALL SPEEDS**
Paradym is the first driver to utilize Callaway's industry-leading face cup technology. We've paired the face cup with a powerful, forged titanium face, a combination that provides higher energy transfer to the ball than a standard driver face insert.
- ✓ **ADJUSTABLE PERIMETER WEIGHTING FOR DESIRED SHOT SHAPE**
The driver head features a refined shape with high MOI and adjustable perimeter weighting. From a 15g sliding weight, players can experience an average of 12 yards of shot shape correction.

PARADYM



PARADYM DRIVER



MCA ALDILA ASCENT PL BLUE
40g (WMS, Light)



PROJECT X HZRDUS SILVER
50g (Reg, Stiff) • 60g (Stiff)



PROJECT X HZRDUS BLACK
60g (Stiff, X-Stiff)



GOLF PRIDE TOUR VELVET 360 (50g)



WMS STOCK GRIP LAMKIN ST SOFT UNDERSIZED (44g)

SPECS

Model	Length	Clubhead Volume	Swingweight	Left Hand	Lie
9°	45.75	460cc	D3 (50g)	Yes	57°
10.5°	45.75	460cc	D3 (50g)	Yes	57°
12°	45.75	460cc	D3 (50g)	Yes	57°

**WOMENS LENGTH 44 ½ - SWING WEIGHT C8 (40g)*

COMPARISON CHART

	Paradym	Paradym X	Paradym
Adjustable Weighting	15g Slider	2g (back)	14g(front) - 2g(back)
Jailbreak AI	Yes	Yes	Yes
Forged Ti Face	Yes	Yes	Yes
Launch	High	High	Mid
Spin	Mid	Low	Low
Flight Bias	Neutral	Semi Draw	Neutral
Forgiveness	Highest	Highest	High
Footprint	Large	Large	Mid

PARADYM X



PARADYM X DRIVER

Paradym X model is built for a high launch with high MOI, along with a generously stretched profile at address. This model is best suited for golfers seeking extreme forgiveness and a slight draw bias from their driver.

THE NEW PARADYM IN PERFORMANCE

- ✓ **A PARADYM SHIFT IN DISTANCE FROM AN INDUSTRY-FIRST 360° CARBON CHASSIS**
360° Carbon Chassis promotes unprecedented weight redistribution for maximized distance. The Triaxial Carbon crown and Forged Carbon sole is 43% lighter than a titanium chassis. This massive weight savings is repositioned for higher MOI and increased forgiveness.
- ✓ **SPEED & STABILITY FROM NEW JAILBREAK A.I.**
Our new A.I. designed Jailbreak system provides stability in both the horizontal and torsional direction. Now with a 33% lighter weight design, we've enhanced stability for faster ball speeds from our industry-leading COR.
- ✓ **NEW A.I. DESIGNED FACE OPTIMIZED FOR DOWNRANGE DISPERSION**
An all-new A.I. face optimization enhances speed, launch and spin, and now downrange dispersion. This is the world's most advanced driver face designed by artificial intelligence.
- ✓ **INDUSTRY-LEADING FACE CUP AND FORGED TITANIUM FACE FOR FAST BALL SPEEDS**
Paradym is the first driver to utilize Callaway's industry-leading face cup technology. We've paired the face cup with a powerful, forged titanium face, a combination that provides higher energy transfer to the ball than a standard driver face insert.
- ✓ **HIGH LAUNCH & LOW SPIN FROM A FORGIVING SHAPE**
Paradym X is built for a high launch with high MOI, along with a generously stretched profile at address. This model is best suited for golfers seeking extreme forgiveness and a slight draw bias from their driver. 5g of rear weight is positioned to increase launch and lower spin for maximum carry distance.

PARADYM X



PARADYM X DRIVER



MCA ALDILA ASCENT PL BLUE

40g (WMS, Light, Reg)



PROJECT X HZRDUS SILVER

50g (Reg, Stiff) • 60g (Stiff)



PROJECT X HZRDUS BLACK

60g (Stiff, X-Stiff)



**GOLF PRIDE TOUR
VELVET 360 (50g)**



**WMS STOCK GRIP LAMKIN
ST SOFT UNDERSIZED (44g)**

SPECS

Model	Length	Clubhead Volume	Swingweight	Availability	Lie
9°	45.75	460cc	D3 (50g)	RH/LH	60°
10.5°	45.75	460cc	D3 (50g)	RH/LH	60°
12°	45.75	460cc	D3 (50g)	RH/LH	60°

**WOMENS LENGTH 44 ½ - SWING WEIGHT C8 (40g)*

COMPARISON CHART

	Paradym	Paradym X	Paradym
Adjustable Weighting	15g Slider	2g (back)	14g(front) - 2g(back)
Jailbreak AI	Yes	Yes	Yes
Forged Ti Face	Yes	Yes	Yes
Launch	High	High	Mid
Spin	Mid	Low	Low
Flight Bias	Neutral	Semi Draw	Neutral
Forgiveness	Highest	Highest	High
Footprint	Large	Large	Mid

PARADYM



PARADYM TRIPLE DIAMOND

The Paradym Triple Diamond model is compact, 450cc shape designed for better players who want to work the ball. It's the lowest spinning and lowest launching Paradym model with a neutral ball flight.

THE NEW PARADYM IN PERFORMANCE

- ✓ **A PARADYM SHIFT IN DISTANCE FROM AN INDUSTRY-FIRST 360° CARBON CHASSIS**
360° Carbon Chassis promotes unprecedented weight redistribution for maximized distance. The Triaxial Carbon crown and Forged Carbon sole is 45% lighter than a titanium chassis. This massive weight savings is repositioned for higher MOI and increased forgiveness.
- ✓ **SPEED & STABILITY FROM NEW JAILBREAK A.I.**
Our new A.I. designed Jailbreak system provides stability in both the horizontal and torsional direction. Now with a 33% lighter weight design, we've enhanced stability for faster ball speeds from our industry-leading COR.
- ✓ **NEW A.I. DESIGNED FACE OPTIMIZED FOR DOWNRANGE DISPERSION**
An all-new A.I. face optimization enhances speed, launch and spin, and now downrange dispersion. This is the world's most advanced driver face designed by artificial intelligence.
- ✓ **INDUSTRY-LEADING FACE CUP AND FORGED TITANIUM FACE FOR FAST BALL SPEEDS**
Paradym is the first driver to utilize Callaway's industry-leading face cup technology. We've paired the face cup with a powerful, forged titanium face, a combination that provides higher energy transfer to the ball than a standard driver face insert.
- ✓ **COMPACT SHAPING FOR MORE WORKABILITY**
The Paradym Triple Diamond driver is compact, 450cc shape designed for better players. A 12g back weight can be positioned in the front for lower spin and maximum workability.

PARADYM



PARADYM TRIPLE DIAMOND



PROJECT X HZRDUS BLACK

60g (Reg)



MITSUBISHI CHEMICAL KAI'LI WHITE

60g (Stiff, X-Stiff) • 70g (Stiff, X-Stiff)



GOLF PRIDE TOUR VELVET 360 (50g)

SPECS

Model	Length	Clubhead Volume	Swingweight	Availability	Lie
8°	45.75	460cc	D4 (60g)	RH/LH	57°
9°	45.75	460cc	D4 (60g)	RH/LH	57°
10.5°	45.75	460cc	D4 (60g)	RH/LH	57°

COMPARISON CHART

	Paradym	Paradym X	Paradym
Adjustable Weighting	15g Slider	2g (back)	14g(front) - 2g(back)
Jailbreak AI	Yes	Yes	Yes
Forged Ti Face	Yes	Yes	Yes
Launch	High	High	Mid
Spin	Mid	Low	Low
Flight Bias	Neutral	Semi Draw	Neutral
Forgiveness	Highest	Highest	High
Footprint	Large	Large	Mid

GREAT BIG BERTHA



GREAT BIG BERTHA DRIVER

Our most technologically advanced driver utilizes an ultra-lightweight chassis and easy-to-swing design to increase club head speed and overall distance.

A MATERIAL DIFFERENCE IN PERFORMANCE



LIGHTWEIGHT DESIGN

This easy-to-swing driver is engineered with an ultra-lightweight design for unmatched distance characteristics. It's nearly 30g lighter than a tour driver, and it's an ideal option for golfers who want to increase their swing speed.



FORGED CARBON SOLE & TRIAXIAL CARBON CROWN

To increase MOI, our engineers paired a lightweight Triaxial Carbon crown with a Forged Carbon sole. With all this discretionary weight, our engineers moved the CG lower and deeper to enhance forgiveness while the steel sole plate makes it easier to hit a draw.



JAILBREAK A.I. SPEED FRAME

Our Jailbreak Speed Frame is powered by A.I. for enhanced horizontal and torsional stability. All this stability promotes increased ball speed across the face.



A.I. DESIGNED FLASH FACE

We've now included spin optimization in our industry-leading A.I. face technology. The new formula increases ball speed while lowering spin to increase total distance.

GREAT BIG BERTHA



GREAT BIG BERTHA DRIVER

UST HELIUM NANOCORE

40g (WMS, Light, Reg) • 50g (Light, Reg, Stiff)

**Shaft weights indicate weight class*



WINN DRI-TAC LITE 2.0 (Men's) WINN DRI-TAC 2.0 (WMS)

SPECS

Model	Length	Clubhead Volume	Swingweight	Lie	Availability
9°	45.75"	460cc	D2	60°	RH/LH
10.5°	45.75"	460cc	D2	60°	RH/LH
12°	45.75"	460cc	D2	60°	RH

02

FAIRWAYS

PARADYM



PARADYM FAIRWAY WOOD

The Paradym Fairway Wood features progressive shaping, and it's our most robust offering that fits a wide range of player types. This is the model for golfers who want a high launching fairway wood with a neutral ball flight.

THE NEW PARADYM IN PERFORMANCE



SPEED & STABILITY FROM JAILBREAK WITH BATWING TECHNOLOGY

The A.I. Designed Jailbreak Batwing structure is pushed to the perimeter to stiffen the body, while allowing the face to flex for high ball speeds.



A PARADYM SHIFT IN DISTANCE FROM PATENTED USE OF FORGED CARBON

The Forged Carbon sole enables unprecedented weight redistribution for maximized distance, higher MOI, and our longest fairway wood ever. *Featured in the 3W, 3HL, & 5W Models.



OPTIMAL LAUNCH WITH MORE SPEED FROM THE TUNGSTEN SPEED CARTRIDGE

By incorporating up to 23g of high-density tungsten, we can push the center of gravity (CG) low and forward. The result is optimal launch and spin, with more speed for maximum distance.



NEW A.I. DESIGNED HIGH-STRENGTH FACE CUP FOR OPTIMIZED DISPERSION

We've applied an all new A.I. face optimization to include speed, launch, spin and now downrange dispersion. The unique face pattern is customized for each model and paired with our high-strength C300 maraging steel face cup. This promotes impressive speed and consistency across the face.



REFINED SHAPING WITH ADJUSTABILITY FOR MORE VERSATILITY

With progressive shaping and the most extensive offering, Paradym Fairway Woods will be the go-to model for players who want consistent launch with ease and a neutral ball flight. An adjustable hosel in the 3W and 3HL models gives players additional control to dial in launch.

PARADYM



PARADYM FAIRWAY WOOD



MCA ALDILA ASCENT PL BLUE
40g (WMS, Light)



PROJECT X HZRDUS SILVER
50g (Reg, Stiff) • 60g (Stiff)



PROJECT X HZRDUS BLACK
60g (Stiff, X-Stiff)

**Shaft weights indicate weight class*



**GOLF PRIDE TOUR
VELVET 360 (50g)**



**WMS STOCK GRIP LAMKIN
ST SOFT UNDERSIZED (44g)**

SPECS

Model	Loft	Length	Clubhead Volume	Swingweight				Availability	Lie	Adjustability
3W	15°	43.25"	171cc	D1 (40g)	D2 (50g)	D3 (60/70g)	D4 (70g)	RH/LH	56"	YES
3HL	16.5°	43.25"	171cc	D1 (40g)	D2 (50g)	D3 (60/70g)	D4 (70g)	RH	56"	YES
5W	18°	42.75"	154cc	D1 (40g)	D2 (50g)	D3 (60/70g)	D4 (70g)	RH/LH	56.5°	-
7W	21°	42.25"	145cc	D1 (40g)	D2 (50g)	D3 (60/70g)	D4 (70g)	RH/LH	57"	-
9W	24°	41.75"	138cc	D1 (40g)	D2 (50g)	D3 (60/70g)	D4 (70g)	RH	58"	-
11W	27°	41.25"	133cc	D1 (40g)	D2 (50g)	D3 (60/70g)	D4 (70g)	RH	59"	-
HVN	20°	43"	165cc	D1 (40g)	D2 (50g)	D3 (60/70g)	D4 (70g)	RH	57"	-

Adjustability only on 3 and 3HL

*WOMENS LENGTH 1 1/4" under - SWING WEIGHT C7

COMPARISON CHART

TECHNOLOGY	Paradym	Paradym X	Paradym ◇◇◇
Tungsten Speed Cartridge	27g	27g	28g
Jailbreak ST	Y	Y	Y
A.I. Designed Flash Face	Y	Y	Y
Adjustable Weighting (g)	N	N	5g (Front)
PERFORMANCE CHARACTERISTICS			
Launch	High	Highest	Mid
Spin	Mid	Mid	Low
Flight Bias	Neutral	Semi Draw	Neutral
Forgiveness	High	Highest	Semi
Face Profile	Shallow	Shallow	Deeper
Footprint	Mid-Sized	Mid-Sized	Compact
SPECS + OPTIONS			
Loft Options	3, 3HL, 5, 7, HVN, 9, 11	3, 3HL, 5, 7	3+, 3, 5

PARADYM X



PARADYM X FAIRWAY WOOD

The Paradym X fairway wood will fit players looking for our most forgiving shape with a high launch and a slight draw bias. A Forged Carbon toe patch redistributes weight to the heel to make this fairway easy to turn over. X model will fit players looking for our most forgiving shape with a high launch and a slight draw bias.

THE NEW PARADYM IN PERFORMANCE



SPEED & STABILITY FROM JAILBREAK WITH BATWING TECHNOLOGY

The A.I. Designed Jailbreak Batwing structure is pushed to the perimeter to stiffen the body, while allowing the face to flex for high ball speeds.



A PARADYM SHIFT IN DISTANCE FROM PATENTED USE OF FORGED CARBON

The Forged Carbon sole enables unprecedented weight redistribution for maximized distance, higher MOI, and our longest fairway wood ever. *Featured in the 3W, 3HL, & 5W Models.



OPTIMAL LAUNCH WITH MORE SPEED FROM THE TUNGSTEN SPEED CARTRIDGE

By incorporating up to 23g of high-density tungsten, we can push the center of gravity (CG) low and forward. The result is optimal launch and spin, with more speed for maximum distance.



NEW A.I. DESIGNED HIGH-STRENGTH FACE CUP FOR OPTIMIZED DISPERSION

We've applied an all new A.I. face optimization to include speed, launch, spin and now downrange dispersion. The unique face pattern is customized for each model and paired with our high-strength C300 maraging steel face cup. This promotes impressive speed and consistency across the face.



HIGHEST LAUNCHING WITH SLIGHT DRAW BIAS

The Paradym X fairway wood is built with a more upright lie angle and a neutral face at address. This model features the most forgiving shape of all Paradym models and will produce the highest launch with a slight draw bias. An adjustable 3W gives the golfer the ability to even further dial in launch.

PARADYM X



PARADYM X FAIRWAY WOOD



MCA ALDILA ASCENT PL BLUE

40g (WMS, Light) • 50g (Light, Reg)



PROJECT X HZRDUS SILVER

60g (Reg, Stiff) • 70g (Stiff)

**Shaft weights indicate weight class*



**GOLF PRIDE TOUR
VELVET 360 (50g)**



**WMS STOCK GRIP LAMKIN
ST SOFT UNDERSIZED (44g)**

SPECS

Model	Loft	Length	Clubhead Volume	Swingweight				Availability	Lie	Adjustability
3W	15°	43.25"	177cc	D1 (40g)	D2 (50g)	D3 (60/70g)	D4 (70g)	RH/LH	58"	YES
3HL	16.5°	43.25"	177cc	D1 (40g)	D2 (50g)	D3 (60/70g)	D4 (70g)	RH	58"	-
5W	18°	42.75"	154cc	D1 (40g)	D2 (50g)	D3 (60/70g)	D4 (70g)	RH/LH	58.5°	-
7W	21°	42.25"	140cc	D1 (40g)	D2 (50g)	D3 (60/70g)	D4 (70g)	RH	59"	-

**Adjustability only on 3*

**WOMENS LENGTH 44 ½ - SWING WEIGHT C8 (40g)*

COMPARISON CHART

TECHNOLOGY	Paradym	Paradym X	Paradym ◇◇◇
Tungsten Speed Cartridge	27g	27g	28g
Jailbreak ST	Y	Y	Y
A.I. Designed Flash Face	Y	Y	Y
Adjustable Weighting (g)	N	N	5g (Front)

PERFORMANCE CHARACTERISTICS			
Launch	High	Highest	Mid
Spin	Mid	Mid	Low
Flight Bias	Neutral	Semi Draw	Neutral
Forgiveness	High	Highest	Semi
Face Profile	Shallow	Shallow	Deeper
Footprint	Mid-Sized	Mid-Sized	Compact

SPECS + OPTIONS			
Loft Options	3, 3HL, 5, 7, HVN, 9, 11	3, 3HL, 5, 7	3+, 3, 5

PARADYM



PARADYM FAIRWAY WOOD

The Paradym Triple Diamond model is our most compact fairway wood shape with a deeper face at address. This offering is best suited for stronger players who are looking for a penetrating ball flight with lower spin.

THE NEW PARADYM IN PERFORMANCE



SPEED & STABILITY FROM JAILBREAK WITH BATWING TECHNOLOGY

The A.I. Designed Jailbreak Batwing structure is pushed to the perimeter to stiffen the body, while allowing the face to flex for high ball speeds.



OPTIMAL LAUNCH WITH MORE SPEED FROM THE TUNGSTEN SPEED CARTRIDGE

By incorporating up to 21g of high-density tungsten, we can push the center of gravity (CG) low and forward. The result is optimal launch and spin, with more speed for maximum distance.



NEW A.I. DESIGNED HIGH-STRENGTH FACE CUP FOR OPTIMIZED DISPERSION

We've applied an all new A.I. face optimization to include speed, launch, spin and now downrange dispersion. The unique face pattern is customized for each model and paired with our high-strength C300 maraging steel face cup. This promotes impressive speed and consistency across the face.



PENETRATING FLIGHT WITH LOW SPIN FROM PARADYM SHIFT CONSTRUCTION

The Paradym Triple Diamond is designed with a deeper face and compact, player preferred shape. The Triaxial Carbon crown and aids in creating a low and forward CG. This produces a penetrating ball flight with low spin. And an adjustable hosel allows golfers to further dial in trajectory.

PARADYM



PARADYM FAIRWAY WOOD



PROJECT X HZRDUS BLACK
70g (Reg)



MITSUBISHI CHEMICAL KAI'LI WHITE
70g (Stiff, X-Stiff) • 80g (Stiff, X-Stiff)

**Shaft weights indicate weight class*



GOLF PRIDE TOUR VELVET 360 (50g)

SPECS

Model	Loft	Length	Clubhead Volume	Swingweight		Availability	Lie	Adjustability
3+	13.5°	43.25"	174cc	D4 (70g)	D5 (80g)	RH	58"	YES
3W	15°	43.25"	174cc	D4 (70g)	D5 (80g)	RH/LH	58"	YES
5W	18°	42.75"	154cc	D4 (70g)	D5 (80g)	RH/LH	58.5°	YES

**Adjustability on all lofts for Triple Diamond*
**WOMENS LENGTH 44 ½ - SWING WEIGHT C8 (40g)*

COMPARISON CHART

TECHNOLOGY	Paradym	Paradym X	Paradym
Tungsten Speed Cartridge	27g	27g	28g
Jailbreak ST	Y	Y	Y
A.I. Designed Flash Face	Y	Y	Y
Adjustable Weighting (g)	N	N	5g (Front)
PERFORMANCE CHARACTERISTICS			
Launch	High	Highest	Mid
Spin	Mid	Mid	Low
Flight Bias	Neutral	Semi Draw	Neutral
Forgiveness	High	Highest	Semi
Face Profile	Shallow	Shallow	Deeper
Footprint	Mid-Sized	Mid-Sized	Compact
SPECS + OPTIONS			
Loft Options	3, 3HL, 5, 7, HVN, 9, 11	3, 3HL, 5, 7	3+, 3, 5

GREAT BIG BERTHA



GREAT BIG BERTHA FAIRWAY

Our most powerful fairway wood ever utilizes a titanium construction, Forged Carbon sole, and multi-material weighting to increase ball speeds and improve forgiveness.

A MATERIAL DIFFERENCE IN PERFORMANCE



TITANIUM FACE & BODY

Usually reserved for drivers, titanium provides Great Big Bertha with a significant weight and strength advantage compared to a traditional steel fairway wood. This weight savings enables us to create a larger, more forgiving footprint and an ultra-low CG that steel does not allow.



A.I. DESIGNED TITANIUM FACE CUP & JAILBREAK WITH BATWING TECHNOLOGY

The titanium face is uniquely optimized for each fairway wood head through A.I. for enhanced ball speed and spin consistency in a powerful design. Our Jailbreak with Batwing Technology pushes stiffness to the perimeter, while still allowing the face to flex for high ball speeds across the face.



MULTI-MATERIAL CONSTRUCTION

A Triaxial Carbon crown and Forged Carbon sole plate save significant weight vs. traditional steel. With all this discretionary weight, our engineers leveraged 50g of internal tungsten and a 15g steel plate on the sole to create an easier, higher launch.



PREMIUM ULTRA-LIGHTWEIGHT COMPONENTS

An ultra-premium UST Helium Nanocore shaft, combined with a Winn Dri-Tac Lite grip make the club easy to swing while the adjustable hosel allows the golfer to dial in launch.

GREAT BIG BERTHA



GREAT BIG BERTHA FAIRWAY

UST HELIUM NANOCORE

40g (WMS, Light, Reg) • 50g (Light, Reg, Stiff) • 60g (Light, Reg, Stiff)

**Shaft weights indicate weight class*



WINN DRI-TAC LITE 2.0 (Men's) WINN DRI-TAC 2.0 (WMS)

SPECS

Model	Loft	Lie	Length	Clubhead Volume	Swingweight	Availability
3FW	15°	56°	43.25"	186CC	40G/50G SHAFTS: D2 / 60G SHAFTS: D5	RH/LH
5FW	18°	56.5°	42.75"	159CC	40G/50G SHAFTS: D2 / 60G SHAFTS: D5	RH/LH
7FW	21°	57°	42.25"	148CC	40G/50G SHAFTS: D2 / 60G SHAFTS: D5	RH
9FW	24°	57.5°	41.75"	140CC	40G/50G SHAFTS: D2 / 60G SHAFTS: D5	RH

03

HYBRIDS

PARADYM

**PARADYM HYBRID**

The Paradym model is for golfers who want a mid-sized, wood-shaped hybrid that's long with excellent versatility and control.

THE NEW PARADYM IN PERFORMANCE

**FAST BALL SPEEDS FROM THE ALL-NEW TUNGSTEN SPEED CARTRIDGE & JAILBREAK WITH BATWING TECHNOLOGY**

Get more distance from the revolutionary Tungsten Speed Cartridge. By incorporating high-density tungsten, we can push the center of gravity (CG) low and forward. The result is lower spin with more ball speed. Our A.I. designed Jailbreak with Batwing Technology increases stiffness in the perimeter, while allowing the face to flex for high ball speeds across the face.

**A.I. DESIGNED 455 FACE CUP FOR OPTIMIZED SPEED AND SPIN**

A high-strength 455 Face Cup is designed using A.I. to optimize ball speeds and improve spin robustness across the face. Each model features a unique A.I. pattern to enhance performance in that specific head.

**INCREDIBLE VERSATILITY FROM THE ALL-NEW CUTWAVE SOLE DESIGN**

An all-new Cutwave Sole is designed specifically to cut through the turf with ease, especially from thick rough. And increased camber on the leading edge improves turf interaction. This brand-new shape makes Paradym the most versatile family of hybrids we've ever created.

**OPTIMAL TRAJECTORY FROM AN ADJUSTABLE HOSEL**

Optimize trajectory and control with an adjustable hosel sleeve capable of +2* / -1* of loft.

PARADYM



PARADYM HYBRID



MCA ALDILA ASCENT PL BLUE
40g (WMS) • 50g (Light, Reg)



PROJECT X HZRDUS SILVER
60g (Reg, Stiff) • 70g (Stiff)

**Shaft weights indicate weight class*



CALLAWAY UNIVERSAL GRIP (51g)



WMS STOCK GRIP LAMKIN ST SOFT UNDERSIZED (44g)

SPECS

Model	Loft	Length	Lie	Swingweight	Availability
18°	18° Adj	40.5"	57.5	D1	RH/LH
21°	21° Adj	40.0"	58	D1	RH/LH
24°	24° Adj	39.5"	58.5	D1	RH/LH
27°	27° Adj	39.0"	59	D1	RH

COMPARISON CHART

Attributes	Paradym	Paradym X
Jailbreak with Batwing Technology	Yes	Yes
Tungsten Speed Cartridge	Yes	Yes
Forged A.I. 455 Face Cup	Yes	Yes
Adjustability	All Models	All Models
Head Shape	Fairway Wood-like	Fairway Wood-like
Launch	Mid	High
Footprint	Moderate	Oversized
Launch	High	Highest
Flight Bias	Neutral	Semi-Draw

PARADYM X



PARADYM X HYBRID

The Paradym X model is for golfers looking for full-sized, wood-shaped hybrid that's long with excellent versatility and forgiveness.

THE NEW PARADYM IN PERFORMANCE



FAST BALL SPEEDS FROM THE ALL-NEW TUNGSTEN SPEED CARTRIDGE & JAILBREAK WITH BATWING TECHNOLOGY

Get more distance from the revolutionary Tungsten Speed Cartridge. By incorporating high-density tungsten, we can push the center of gravity (CG) low and forward. The result is lower spin with more ball speed. Our A.I. designed Jailbreak with Batwing Technology increases stiffness in the perimeter, while allowing the face to flex for high ball speeds across the face.



A.I. DESIGNED 455 FACE CUP FOR OPTIMIZED SPEED AND SPIN

A high-strength 455 Face Cup is designed using A.I. to optimize ball speeds and improve spin robustness across the face. Each model features a unique A.I. pattern to enhance performance in that specific head.



INCREDIBLE VERSATILITY FROM THE ALL-NEW CUTWAVE SOLE DESIGN

An all-new Cutwave Sole is designed specifically to cut through the turf with ease, especially from thick rough. And increased camber on the leading edge improves turf interaction. This brand-new shape makes Paradym the most versatile family of hybrids we've ever created.



OPTIMAL TRAJECTORY FROM AN ADJUSTABLE HOSEL

Optimize trajectory and control with an adjustable hosel sleeve capable of +2*/ -1* of loft.

PARADYM X



PARADYM X HYBRID



MCA ALDILA ASCENT PL BLUE
40g (WMS) • 50g (Light)



PROJECT X HZRDUS SILVER
60g (Reg) • 70g (Stiff)

**Shaft weights indicate weight class*



CALLAWAY UNIVERSAL GRIP (51g)



WMS STOCK GRIP LAMKIN ST SOFT UNDERSIZED (44g)

SPECS

Model	Loft	Length	Lie	Swingweight	Availability
3	18° Adj	40.5"	57.5	D1	RH/LH
4	21° Adj	40.0"	58	D1	RH/LH
5	24° Adj	39.5"	58.5	D1	RH/LH
6	27° Adj	39.0"	59	D1	RH
7	30° Adj	38.5"	59.5	D1	RH

COMPARISON CHART

Attributes	Paradym	Paradym X
Jailbreak with Batwing Technology	Yes	Yes
Tungsten Speed Cartridge	Yes	Yes
Forged A.I. 455 Face Cup	Yes	Yes
Adjustability	All Models	All Models
Head Shape	Fairway Wood-like	Fairway Wood-like
Launch	Mid	High
Footprint	Moderate	Oversized
Launch	High	Highest
Flight Bias	Neutral	Semi-Draw

GREAT BIG BERTHA



GREAT BIG BERTHA HYBRID

Our most advanced hybrid ever is built from driver DNA, creating exceptional ball speed and forgiveness on a wide variety of shots.

A MATERIAL DIFFERENCE IN PERFORMANCE



TITANIUM FACE & BODY

Titanium is extremely lightweight, yet it's also incredibly strong. Our engineers leveraged a titanium face and body, resulting in 100g of discretionary saved weight. The weight is redistributed to enhance ball speed, improve forgiveness, and promote an easy launch.



A.I. DESIGNED TITANIUM FACE CUP & JAILBREAK WITH BATWING TECHNOLOGY

The titanium face has been uniquely optimized through A.I. to enhance ball speed and spin consistency, especially on off-center hits. The A.I. designed Jailbreak with Batwing Technology increases stiffness in the perimeter, while allowing the face to flex for high ball speeds across the face.



MULTI-MATERIAL CONSTRUCTION

A Triaxial Carbon crown and Forged Carbon sole plate save significant weight vs. traditional steel. The weight savings is then meticulously redistributed to optimize CG and promote high launch with more forgiveness.



DUAL TUNGSTEN WEIGHTING

With the substantial amount of discretionary weight available from titanium, our engineers redistributed up to 78g of weight between internal tungsten and the sole plate to promote faster ball speeds and a higher launch.



REDEFINED SHAPE

The sole has also been enhanced with more camber to improve turf interaction and versatility from tough lies. It also features an adjustable hosel in all lofts to dial in launch. Great Big Bertha hybrids feature a slightly more compact, fairway wood-like shape.

GREAT BIG BERTHA



GREAT BIG BERTHA HYBRID

UST HELIUM NANOCORE

50g (WMS) • 60g (Light, Reg, Stiff)

**Shaft weights indicate weight class*



WINN DRI-TAC LITE 2.0

SPECS

Model	Loft	Lie	Length	Swingweight	Availability
3H	18°	57°	40.75"	D2	RH/LH
4H	20°	57.5°	40.25"	D2	RH/LH
5H	23°	58°	39.75"	D2	RH/LH
6H	26°	58.5°	39.25"	D2	RH/LH
7H	29°	59°	38.75"	D2	RH
8H	32°	59.5°	38.25"	D2	RH

04

IRONS

PARADYM



PARADYM IRON

The Paradym iron is designed for golfers who are looking for a players' distance iron with a refined shape and premium forging.

THE NEW PARADYM IN PERFORMANCE



OUR MOST POWERFUL A.I. DESIGNED FORGED 455 FACE

Industry-leading A.I. face technology is applied to a high-strength Forged 455 face, creating our most powerful forged iron face ever. Each face is uniquely optimized for more speed, higher launch, and increased spin consistency.



FAST BALL SPEEDS FROM FORGED 455 FACE CUP AND HOLLOW BODY WITH SPEED FRAME CONSTRUCTION

The all-new Hollow Body design features Speed Frame construction for added stiffness to the body and support for the high-strength Forged 455 Face Cup. This unique construction is the catalyst that stabilizes a thinner face for incredibly fast ball speeds.



EXCEPTIONAL FEEL FROM A FORGED FACE AND PATENTED URETHANE MICROSPHERES

A forged face and patented Urethane Microspheres deliver the ultra-soft feel and premium sound that discerning players demand.



IMPROVED LAUNCH VIA DUAL TUNGSTEN WEIGHTING

Up to 67g of external and internal tungsten weights are placed precisely to enhance launch conditions and improve speed on mis-hits. This increase in forgiveness is the difference between hitting the green and coming up short.



REFINED PLAYERS SHAPING

The Paradym iron features a players look in a forgiving package. A pre-worn leading edge is designed to cut through the turf more efficiently for even more forgiveness.

PARADYM



PARADYM IRON



MCA Aldila Ascent PL Blue 50g (Light)



Project X HZRDUS Silver 60g (Reg) • 70g (Stiff)



True Temper Elevate MPH 95 95g (Reg, Stiff)

**Shaft weights indicate weight class*



CALLAWAY UNIVERSAL GRIP (51g)



WMS STOCK GRIP LAMKIN ST SOFT UNDERSIZED (44g)

SPECS

Model	Loft	Length	Lie	Swingweight (Steel)	Swingweight (Graphite)	Availability	Offset (mm)
4	20°	38.875"	61	D2	D1	RH/LH	3.8
5	23°	38.25"	61.5	D2	D1	RH/LH	3.4
6	26°	37.625"	62	D2	D1	RH/LH	3
7	29°	37.00"	62.5	D2	D1	RH/LH	2.8
8	33°	36.50"	63	D2	D1	RH/LH	2.5
9	37°	36.00"	63.5	D2	D1	RH/LH	2.3
P	42°	35.75"	64	D2	D1	RH/LH	2
A	47°	35.50"	64	D2	D1	RH/LH	1.8
52/G	52°	35.25"	64	D2	D1	RH/LH	1.8

COMPARISON CHART

Attributes	Forged A.I. 455 Face	Urethane Microspheres	Tungsten Weighting	Head Shape	Sole Width	Topline	Offset	Player Category	Handicap Range
Paradym	Yes	Yes	Up to 67g	Compact	Moderate	Slim	Minimal	Players Distance	4 to 12
Paradym X	Yes	Yes	Up to 79g	Mid-Sized	Wide	Moderate	Moderate	Game-Improvement	12+

PARADYM X



PARADYM X IRON

The Paradym X Irons are designed for golfers who are looking for an iron that's incredibly long with premium forged feel.

THE NEW PARADYM IN PERFORMANCE



OUR MOST POWERFUL A.I. DESIGNED FORGED 455 FACE

Industry-leading A.I. face technology is applied to a high-strength Forged 455 face, creating our most powerful forged iron face ever. Each face is uniquely optimized for more speed, higher launch, and increased spin consistency.



FAST BALL SPEEDS FROM FORGED 455 FACE CUP AND HOLLOW BODY WITH SPEED FRAME CONSTRUCTION

The all-new Hollow Body design features Speed Frame construction for added stiffness to the body and support for the high-strength Forged 455 Face Cup. This unique construction is the catalyst that stabilizes a thinner face for incredibly fast ball speeds.



EXCEPTIONAL FEEL FROM A FORGED FACE AND PATENTED URETHANE MICROSPHERES

A forged face and patented Urethane Microspheres deliver the ultra-soft feel and premium sound that discerning players demand.



IMPROVED LAUNCH VIA DUAL TUNGSTEN WEIGHTING

Up to 79g of external and internal tungsten weights are placed precisely to enhance launch conditions and improve speed on mis-hits. This increase in forgiveness is the difference between hitting the green and coming up short.



REFINED PLAYERS SHAPING

The Paradym X iron features a thicker topline and forgiving sole. A pre-worn leading edge is designed to cut through the turf more efficiently for even more forgiveness.

PARADYM X



PARADYM X IRON

MCA Aldila Ascent PL Blue 40g (WMS) • 50g (Light)

Project X HZRDUS Silver 60g (Reg) • 70g (Stiff)

True Temper Elevate MPH 85 85g (Reg, Stiff)

**Shaft weights indicate weight class*

CALLAWAY UNIVERSAL GRIP (51g)

WMS STOCK GRIP LAMKIN ST SOFT UNDERSIZED (44g)

SPECS

Model	Loft	Length	Lie	Swingweight (Steel)	Swingweight (Graphite)	Availability	Offset (mm)
4	18.5°	38.875"	61	D2	D1	RH/LH	6.4
5	21.5°	38.25"	61.5	D2	D1	RH/LH	5.8
6	24.5°	37.625"	62	D2	D1	RH/LH	5.3
7	27.5°	37.00"	62.5	D2	D1	RH/LH	4.8
8	31.5°	36.50"	63	D2	D1	RH/LH	4.5
9	36°	36.00"	63.5	D2	D1	RH/LH	4.2
P	41°	35.75"	64	D2	D1	RH/LH	3.9
A	46°	35.50"	64	D2	D1	RH/LH	3.7
51/G	51°	35.25"	64	D2	D1	RH/LH	3.6
56/S	56°	35.00"	64	D2	D1	RH/LH	3.4

COMPARISON CHART

Attributes	Forged A.I. 455 Face	Urethane Microspheres	Tungsten Weighting	Head Shape	Sole Width	Topline	Offset	Player Category	Handicap Range
Paradym	Yes	Yes	Up to 67g	Compact	Moderate	Slim	Minimal	Players Distance	4 to 12
Paradym X	Yes	Yes	Up to 79g	Mid-Sized	Wide	Moderate	Moderate	Game-Improvement	12+

GREAT BIG BERTHA



GREAT BIG BERTHA IRON

This is the titanium iron reinvented--Callaway's first ultra-premium multi-piece, titanium design. We are combining driver-like power with the precision of an iron. By combining our titanium face and body with up to 145g of tungsten, we've reached a new level of speed, forgiveness, and overall performance.

A MATERIAL DIFFERENCE IN PERFORMANCE



FORGED TITANIUM FACE & CP4 TITANIUM BODY

By leveraging materials that are typically reserved for drivers, we've generated up to 96g of discretionary weight, and precisely repositioned this saved weight to increase launch and forgiveness. The Commercially Pure Grade 4 (CP4) Titanium body flexes more at impact than traditional steel and works together with the thinner face to transfer more energy to the ball.



TUNGSTEN SPEED CARTRIDGE

The Tungsten Speed Cartridge features up to 145g of high-density tungsten, which provides increased speed and launch by giving us the deepest center of gravity we've ever achieved in an iron. This unmatched level of tungsten is a 133% increase over Rogue ST Max, and the most ever in a Callaway iron.



A.I.-DESIGNED FORGED TITANIUM FACE

The forged titanium face is optimized to increase speed and improve spin consistency. Great Big Bertha is the first Callaway iron to combine titanium and industry-leading A.I. technologies for optimized performance.



PATENTED URETHANE MICROSPHERES

Our patented urethane microspheres enhance sound and deliver a softer feel, while still allowing the face to flex for more ball speed.

GREAT BIG BERTHA



GREAT BIG BERTHA IRON

NIPPON NS PRO 850GH NEO

85g (Reg, Stiff)

UST HELIUM NANOCORE

50g (WMS) • 60g (Light, Reg, Stiff)

**Shaft weights indicate weight class*



WINN DRI-TAC LITE 2.0

SPECS

Model	Loft	Lie	Length	Offset (mm)	Swingweight	Availability
4	20°	60.5°	38.75"	5.08mm	D1 (Graphite/Steel)	RH/LH
5	23°	61.25°	38.125"	4.57mm	D1 (Graphite/Steel)	RH/LH
6	26°	62°	37.5"	4.06mm	D1 (Graphite/Steel)	RH/LH
7	30°	62.5°	37"	3.81mm	D1 (Graphite/Steel)	RH/LH
8	34°	63°	36.5"	3.56mm	D1 (Graphite/Steel)	RH/LH
9	38°	63.5°	36"	3.30mm	D1 (Graphite/Steel)	RH/LH
PW	43°	64°	35.75"	3.05mm	D1 (Graphite/Steel)	RH/LH
AW	48°	64°	35.5"	2.79mm	D1 (Graphite/Steel)	RH/LH
SW	54°	64°	35.25"	2.54mm	D1 (Graphite/Steel)	RH/LH



05

WOMENS

PARADYM



WOMEN'S PARADYM DRIVER

The Paradym driver model provides a refined shape with high MOI and adjustable perimeter weighting. Engineered for players of all skill levels, this club promotes high launch and low spin characteristics along with a neutral ball flight. It's our best combination of distance, forgiveness, and adjustability.

THE NEW PARADYM IN PERFORMANCE



REVOLUTIONARY A PARADYM SHIFT IN DISTANCE FROM AN INDUSTRY-FIRST 360° CARBON CHASSIS

360° Carbon Chassis promotes unprecedented weight redistribution for maximized distance. The Triaxial Carbon crown and Forged Carbon sole is 44% lighter than a titanium chassis. This massive weight savings is repositioned for higher MOI and increased forgiveness.



SPEED & STABILITY FROM NEW JAILBREAK A.I.

Our new A.I. designed Jailbreak system provides stability in both the horizontal and torsional direction. Now with a 25% lighter weight design, we've enhanced stability for faster ball speeds from our industry-leading COR.



NEW A.I. DESIGNED FACE OPTIMIZED FOR DOWNRANGE DISPERSION

An all-new A.I. face optimization enhances speed, launch and spin, and now downrange dispersion. This is the world's most advanced driver face designed by artificial intelligence.



INDUSTRY-LEADING FACE CUP AND FORGED TITANIUM FACE FOR FAST BALL SPEEDS

Paradym is the first driver to utilize Callaway's industry-leading face cup technology. We've paired the face cup with a powerful, forged titanium face, a combination that provides higher energy transfer to the ball than a standard driver face insert.



ADJUSTABLE PERIMETER WEIGHTING FOR DESIRED SHOT SHAPE

The driver head features a refined shape with high MOI and adjustable perimeter weighting. From a 15g sliding weight, players can experience an average of 12 yards of shot shape correction.

PARADYM



WOMEN'S PARADYM DRIVER



MCA ALDILA ASCENT PL BLUE

40g

**Shaft weights indicate weight class*



WMS STOCK GRIP LAMKIN ST SOFT UNDERSIZED

44g

SPECS

Model	Length	Clubhead Volume	Swingweight	Left Hand	Lie	Adjustability
9°	44.5"	460cc	C8 (40g)	Yes	57°	Yes
10.5°	44.5"	460cc	C8 (40g)	Yes	57°	Yes
12°	44.5"	460cc	C8 (40g)	Yes	57°	Yes

Adjustability on all lies

COMPARISON CHART

	Paradym	Paradym X
Adjustable Weighting	15g Slider	2g (back)
Jailbreak AI	Yes	Yes
Forged Ti Face	Yes	Yes
Launch	High	High
Spin	Mid	Low
Flight Bias	Neutral	Semi Draw
Forgiveness	Highest	Highest
Footprint	Large	Large

PARADYM X



WOMEN'S PARADYM X DRIVER

Paradym X model is built for a high launch with high MOI, along with a generously stretched profile at address. This model is best suited for golfers seeking extreme forgiveness and a slight draw bias from their driver.

THE NEW PARADYM IN PERFORMANCE



REVOLUTIONARY A PARADYM SHIFT IN DISTANCE FROM AN INDUSTRY-FIRST 360° CARBON CHASSIS

360° Carbon Chassis promotes unprecedented weight redistribution for maximized distance. The Triaxial Carbon crown and Forged Carbon sole is 44% lighter than a titanium chassis. This massive weight savings is repositioned for higher MOI and increased forgiveness.



SPEED & STABILITY FROM NEW JAILBREAK A.I.

Our new A.I. designed Jailbreak system provides stability in both the horizontal and torsional direction. Now with a 25% lighter weight design, we've enhanced stability for faster ball speeds from our industry-leading COR.



NEW A.I. DESIGNED FACE OPTIMIZED FOR DOWNRANGE DISPERSION

An all-new A.I. face optimization enhances speed, launch and spin, and now downrange dispersion. This is the world's most advanced driver face designed by artificial intelligence.



INDUSTRY-LEADING FACE CUP AND FORGED TITANIUM FACE FOR FAST BALL SPEEDS

Paradym is the first driver to utilize Callaway's industry-leading face cup technology. We've paired the face cup with a powerful, forged titanium face, a combination that provides higher energy transfer to the ball than a standard driver face insert.



HIGH LAUNCH & LOW SPIN FROM A FORGIVING SHAPE

Paradym X is built for a high launch with high MOI, along with a generously stretched profile at address. This model is best suited for golfers seeking extreme forgiveness and a slight draw bias from their driver. 5g of rear weight is positioned to increase launch and lower spin for maximum carry distance.

PARADYM X



WOMEN'S PARADYM X DRIVER



MCA ALDILA ASCENT PL BLUE

40g

**Shaft weights indicate weight class*



WMS STOCK GRIP LAMKIN ST SOFT UNDERSIZED

44g

SPECS

Model	Length	Clubhead Volume	Swingweight	Left Hand	Lie
9	44.5"	460cc	C8 (40g)	Yes	60°
10.5	44.5"	460cc	C8 (40g)	Yes	60°
12	44.5"	460cc	C8 (40g)	Yes	60°

COMPARISON CHART

	Paradym	Paradym X
Adjustable Weighting	15g Slider	2g (back)
Jailbreak AI	Yes	Yes
Forged Ti Face	Yes	Yes
Launch	High	High
Spin	Mid	Low
Flight Bias	Neutral	Semi Draw
Forgiveness	Highest	Highest
Footprint	Large	Large

PARADYM



WOMEN'S PARADYM FAIRWAY WOOD

The Paradym Fairway Wood features progressive shaping, and it's our most robust offering that fits a wide range of player types. This is the model for golfers who want a high launching fairway wood with a neutral ball flight.

THE NEW PARADYM IN PERFORMANCE



SPEED & STABILITY FROM JAILBREAK WITH BATWING TECHNOLOGY

The A.I. Designed Jailbreak Batwing structure is pushed to the perimeter to stiffen the body, while allowing the face to flex for high ball speeds.



A PARADYM SHIFT IN DISTANCE FROM PATENTED USE OF FORGED CARBON

The Forged Carbon sole enables unprecedented weight redistribution for maximized distance, higher MOI, and our longest fairway wood ever. *Featured in the 3W, 3HL, & 5W Models.



OPTIMAL LAUNCH WITH MORE SPEED FROM THE TUNGSTEN SPEED CARTRIDGE

By incorporating up to 23g of high-density tungsten, we can push the center of gravity (CG) low and forward. The result is optimal launch and spin, with more speed for maximum distance.



NEW A.I. DESIGNED HIGH-STRENGTH FACE CUP FOR OPTIMIZED DISPERSION

We've applied an all new A.I. face optimization to include speed, launch, spin and now downrange dispersion. The unique face pattern is customized for each model and paired with our high-strength C300 maraging steel face cup. This promotes impressive speed and consistency across the face.



REFINED SHAPING WITH ADJUSTABILITY FOR MORE VERSATILITY

With progressive shaping and the most extensive offering, Paradym Fairway Woods will be the go-to model for players who want consistent launch with ease and a neutral ball flight. An adjustable hosel in the 3W and 3HL models gives players additional control to dial in launch.

PARADYM



WOMEN'S PARADYM FAIRWAY WOOD



MCA ALDILA ASCENT PL BLUE

40g (WMS, Light)

**Shaft weights indicate weight class*



WMS STOCK GRIP LAMKIN ST SOFT UNDERSIZED
44g

SPECS

Model	Loft	Length	Clubhead Volume	Swingweight	Left Hand	Lie	Adjustability
3W	15°	42"	171cc	C7 (40g)	YES	56"	YES
3HL	16.5°	42"	171cc	C7 (40g)	-	56"	YES
5W	18°	41.5"	154cc	C7 (40g)	YES	56.5°	-
7W	21°	41"	145cc	C7 (40g)	YES	57"	-
9W	24°	40.5"	138cc	C7 (40g)	-	58"	-
11W	27°	40"	133cc	C7 (40g)	-	59"	-
HVN	20°	41.75"	165cc	C7 (40g)	-	57"	-

Adjustability only on 3W and 3HL

COMPARISON CHART

TECHNOLOGY	Paradym	Paradym X
Tungsten Speed Cartridge	27g	27g
Jailbreak ST	Y	Y
A.I. Designed Flash Face	Y	Y
Adjustable Weighting (g)	N	N
PERFORMANCE CHARACTERISTICS		
Launch	High	Highest
Spin	Mid	Mid
Flight Bias	Neutral	Semi Draw
Forgiveness	High	Highest
Face Profile	Shallow	Shallow
Footprint	Mid-Sized	Mid-Sized
SPECS + OPTIONS		
Loft Options	3, 3HL, 5, 7, HVN, 9, 11	3, 3HL, 5, 7

PARADYM X



WOMEN'S PARADYM X FAIRWAY WOOD

The Paradym X fairway wood will fit players looking for our most forgiving shape with a high launch and a slight draw bias. A Forged Carbon toe patch redistributes weight to the heel to make this fairway easy to turn over. X model will fit players looking for our most forgiving shape with a high launch and a slight draw bias.

THE NEW PARADYM IN PERFORMANCE



SPEED & STABILITY FROM JAILBREAK WITH BATWING TECHNOLOGY

The A.I. Designed Jailbreak Batwing structure is pushed to the perimeter to stiffen the body, while allowing the face to flex for high ball speeds.



A PARADYM SHIFT IN DISTANCE FROM PATENTED USE OF FORGED CARBON

The Forged Carbon sole enables unprecedented weight redistribution for maximized distance, higher MOI, and our longest fairway wood ever. *Featured in the 3W, 3HL, & 5W Models.



OPTIMAL LAUNCH WITH MORE SPEED FROM THE TUNGSTEN SPEED CARTRIDGE

By incorporating up to 23g of high-density tungsten, we can push the center of gravity (CG) low and forward. The result is optimal launch and spin, with more speed for maximum distance.



NEW A.I. DESIGNED HIGH-STRENGTH FACE CUP FOR OPTIMIZED DISPERSION

We've applied an all new A.I. face optimization to include speed, launch, spin and now downrange dispersion. The unique face pattern is customized for each model and paired with our high-strength C300 maraging steel face cup. This promotes impressive speed and consistency across the face.



HIGHEST LAUNCHING WITH SLIGHT DRAW BIAS

The Paradym X fairway wood is built with a more upright lie angle and a neutral face at address. This model features the most forgiving shape of all Paradym models and will produce the highest launch with a slight draw bias. An adjustable 3W gives the golfer the ability to even further dial in launch.

PARADYM X



WOMEN'S PARADYM X FAIRWAY WOOD



MCA ALDILA ASCENT PL BLUE

40g (WMS, Light)

**Shaft weights indicate weight class*



WMS STOCK GRIP LAMKIN ST SOFT UNDERSIZED
44g

SPECS

Model	Loft	Length	Clubhead Volume	Swingweight	Left Hand	Lie	Adjustability
3W	15°	42"	171cc	C7 (40g)	YES	56"	YES
3HL	16.5°	42"	171cc	C7 (40g)	-	56"	YES
5W	18°	41.5"	154cc	C7 (40g)	YES	56.5°	-
7W	21°	41"	145cc	C7 (40g)	YES	57"	-
9W	24°	40.5"	138cc	C7 (40g)	-	58"	-
11W	27°	40"	133cc	C7 (40g)	-	59"	-
HVN	20°	41.75"	165cc	C7 (40g)	-	57"	-

Adjustability only on 3W and 3HL

COMPARISON CHART

TECHNOLOGY	Paradym	Paradym X
Tungsten Speed Cartridge	27g	27g
Jailbreak ST	Y	Y
A.I. Designed Flash Face	Y	Y
Adjustable Weighting (g)	N	N
PERFORMANCE CHARACTERISTICS		
Launch	High	Highest
Spin	Mid	Mid
Flight Bias	Neutral	Semi Draw
Forgiveness	High	Highest
Face Profile	Shallow	Shallow
Footprint	Mid-Sized	Mid-Sized
SPECS + OPTIONS		
Loft Options	3, 3HL, 5, 7, HVN, 9, 11	3, 3HL, 5, 7

PARADYM



WOMEN'S PARADYM X HYBRID



MCA ALDILA ASCENT PL BLUE

40g (WMS)



WMS STOCK GRIP LAMKIN
ST SOFT UNDERSIZED (44g)

SPECS

Model	Loft	Length	Lie	Swingweight	Availability
3	18° Adj	39.5"	57.5	C5	RH/LH
4	21° Adj	39"	58	C5	RH/LH
5	24° Adj	38.5"	58.5	C5	RH/LH
6	27° Adj	38"	59	C5	RH
7	30° Adj	37.5"	59.5	C5	RH

PARADYM X



WOMEN'S PARADYM X IRON



MCA Aldila Ascent PL Blue

40g (WMS)

**Shaft weights indicate weight class*



Lamkin ST Soft Undersized (WMS)

SPECS

Model	Loft	Length	Lie	Swingweight (Graphite)	Availability	Offset (mm)
4	18.5°	37 7/8"	61	C5	RH/LH	6.4
5	21.5°	37 1/4"	61.5	C5	RH/LH	5.8
6	24.5°	36 5/8"	62	C5	RH/LH	5.3
7	27.5°	36"	62.5	C5	RH/LH	4.8
8	31.5°	35 1/2"	63	C5	RH/LH	4.5
9	36°	35"	63.5	C5	RH/LH	4.2
P	41°	34 3/4"	64	C5	RH/LH	3.9
A	46°	34 1/2"	64	C5	RH/LH	3.7
51/G	51°	34 1/4"	64	C5	RH/LH	3.6
56/S	56°	34"	64	C5	RH/LH	3.4

REVA



BLACK

BLUE

ROSE GOLD

REVA COMPLETE SET

The REVA Complete Set from Callaway, the #1 brand for women's equipment, is designed with premium performance in mind. This complete offering is engineered for women of all skill levels who want to increase their distance, hit great shots, and enjoy the game more than ever before.

A PREMIUM PERFORMANCE SET FOR WOMEN



LONG DISTANCE OFF THE DRIVER

Designed for the ultimate combination of distance and forgiveness to inspire confidence in every swing.



EASY TO LAUNCH FAIRWAY WOOD

Optimized so that it's easy to hit with a high flying ball flight.



MAXIMUM FORGIVENESS IN THE IRONS

Large, oversized Deep Cavity back Irons designed for easy launch and forgiveness on mishits.



DESIGNED FOR WOMEN'S SWING SPEED

The loft progressions and set makeup are built based on extensive player testing with women's golfers.



TOUR-PROVEN STROKE LAB PUTTER

Features our innovative Stroke Lab shaft to improve the tempo and consistency in your stroke.



GOLF BAG AND HEADCOVERS

Our premium and functional REVA golf bag and headcovers complete the set.



COLOR OPTIONS

Right-handed sets: Available in red, blue and black. Left-handed sets: Only available in black.

REVA



BLACK

BLUE

ROSE GOLD

REVA COMPLETE SET

11 PIECE SET

Includes: Driver, 3W, 5H, 6H, 7IR-PW, Putter and Bag

8 PIECE SET

Includes: Driver, 5W, 5H, 7I, 9IR, SW, Putter and Bag



CALLAWAY REVA WOMENS SHAFT





WOMEN'S BIG BERTHA REVA 11 PIECE COMPLETE SET PRODUCT SPECS

NAME	LOFT	AVAILABILITY	LENGTH	LIE	SWING WEIGHT
DRIVER	12.5°	RH/LH (BLACK SETS), RH ONLY (BLUE SETS)	44.50"	57.0°	C5
3-WOOD	20°	RH/LH (BLACK SETS), RH ONLY (BLUE SETS)	41.00"	57.5°	C4
5H	27°	RH/LH (BLACK SETS), RH ONLY (BLUE SETS)	38.50"	59.5°	C5
6H	30°	RH/LH (BLACK SETS), RH ONLY (BLUE SETS)	37.50"	60.5°	C5
7-IRON	33°	RH/LH (BLACK SETS), RH ONLY (BLUE SETS)	36.50"	62.5°	C6
8-IRON	38°	RH/LH (BLACK SETS), RH ONLY (BLUE SETS)	36.00"	63.0°	C6
9-IRON	43°	RH/LH (BLACK SETS), RH ONLY (BLUE SETS)	35.50"	63.5°	C6
PW	48°	RH/LH (BLACK SETS), RH ONLY (BLUE SETS)	35.00"	64.0°	C6
SW	56°	RH/LH (BLACK SETS), RH ONLY (BLUE SETS)	34.75"	64.0°	C7

E·R·C SOFT REVA™



OUR LONGEST BALL WITH SOFT FEEL AND GREENSIDE CONTROL

- 
NEW GRIP URETHANE COATING FOR INCREASED GREENSIDE SPIN
 This coating system features high-elongation paint for increased control on approach shots and short game shots.
- 
MORE BALL SPEED & SOFT FEEL FROM NEW HYPER ELASTIC SOFTFAST CORE
 Optimized for faster driver speed and soft feel around the green.
- 
HYBRID COVER PROVIDES EXCEPTIONAL FEEL, CONTROL AND SPIN + LONG DISTANCE
 The cover allows us to create a versatile, multi-material construction. This is how we combine maximized distance from high launch and low spin, with soft feel and durability.
- 
HIGH SPEED MANTLE FOR ENHANCED BALL SPEED AND CONTROL
 Creates more efficient energy transfer between the layers for more ball speed and provides more wedge spin around the green.
- 
NEW TRIPLE TRACK DAGGER TECHNOLOGY FOR ADVANCED ALIGNMENT
 Our new Triple Track Dagger lines are prominently featured on ERC Soft to help you find the right alignment for every putt.

ERC Soft is our longest golf ball with soft feel, and for 2023 we've introduced technologies that promote a new level of complete performance. Leading with the cover, we've created an all-new GRIP Urethane Coating System that provides even more greenside spin. The unique cover is paired with an all-new HyperElastic SoftFast core that increase ball speed, while maintaining soft feel through the bag.

These enhanced design features are especially suited for women who want to optimize their performance on the course. Our new technologies properly complement each other, delivering soft feel through the bag, incredible distance with the driver, and added spin for greenside control with your wedges.



WHITE

REVA



The Callaway REVA Golf Ball is engineered for women who want to improve their distance, ball flight and consistency. To promote easy launch and more forgiveness, we've leveraged an oversized construction that conforms to the rules of golf. Our oversized core and low spin characteristics are also designed for longer, more accurate shots. Try the REVA if you're looking to hit better shots that fly on a straighter line.

DESIGNED FOR WOMEN TO UNLOCK YOUR DISTANCE

- 
EASY TO LAUNCH AND MORE FORGIVING
 Promotes higher ball flight for increased distance, and more forgiveness for better accuracy, all from an oversized construction that conforms to the rules of golf.

- 
LONG AND STRAIGHT
 Our oversized core and low spin profile are specifically designed for women to maximize distance and consistency on the course.



WHITE



PINK



06

WEDGES

JAWS RAW



JAWS RAW WEDGE

We're taking spin and control to new levels by leveraging:

- The most aggressive groove in golf to promote a controlled “one hop and stop” trajectory.
- New raw face. Exposes groove edge to promote maximum friction and spin.
- Offset Groove-in-Groove Technology.
- A muted toe pad on the face reduces glare at address.

PURE SPIN IN ITS RAWEST FORM



NEW WEIGHT BALANCED DESIGN FOR ENHANCED FEEL AND IMPROVED SCORING PERFORMANCE

Tungsten is in a Callaway wedge for the first time ever, on the sand and lob wedges, to center the CG position for control and feel. Variable length hosels are engineered to control trajectory while enhancing forgiveness.



VERSATILITY AND SHOT MAKING WITH 17 LOFT / BOUNCE OPTIONS PER FINISH

The all-new Z grind is a more forgiving low bounce option, with an aggressive leading-edge chamfer that improves turf interaction. This chamfer acts as a “skid plate” to help reduce digging on chip and pitch shots. All sand and lob wedge grinds also feature a leading-edge chamfer that is designed to reduce digging.



AVAILABLE IN RAW FACE CHROME AND RAW BLACK PLASMA



Z GRIND

Shotmakers who like to open the face around the greens



S GRIND

Fits a variety of swing types; best for players who prefer a square face



X GRIND

Shotmakers with a steep angle of attack



W GRIND

Our widest sole for players who need the most help and forgiveness

JAWS RAW



JAWS RAW WEDGE



MEN'S GRAPHITE: PROJECT X CATALYST

80g



MEN'S STEEL: TRUE TEMPER DYNAMIC GOLD SPINNER

115g



MEN'S GRIP: LAMKIN UTX CHARCOAL GRIP

MEN'S SPECS

LOFT	AVAILABILITY	BOUNCE	SOLE	STANDARD LENGTH	LIE	STEEL SWING WEIGHT	GRAPHITE SWING WEIGHT
48°	RH ONLY	10°	S-GRIND	35.75"	64.0°	D3	D2
50°	RH / LH	10°	S-GRIND	35.50"	64.0°	D3	D2
50°	RH ONLY	12°	W-GRIND	35.50"	64.0°	D3	D2
52°	RH / LH	10°	S-GRIND	35.50"	64.0°	D3	D2
52°	RH ONLY	12°	W-GRIND	35.50"	64.0°	D3	D2
54°	RH / LH	10°	S-GRIND	35.25"	64.0°	D4	D2
54°	RH / LH	12°	W-GRIND	35.25"	64.0°	D4	D3
56°	RH / LH	10°	S-GRIND	35.25"	64.0°	D4	D3
56°	RH / LH	12°	W-GRIND	35.25"	64.0°	D4	D3
58°	RH / LH	8°	Z-GRIND	35.00"	64.0°	D4	D3
58°	RH / LH	10°	S-GRIND	35.00"	64.0°	D4	D3
58°	RH ONLY	12°	W-GRIND	35.00"	64.0°	D4	D3
58°	RH / LH	12°	X-GRIND	35.00"	64.0°	D4	D3
60°	RH / LH	8°	Z-GRIND	35.00"	64.0°	D4	D3
60°	RH / LH	10°	S-GRIND	35.00"	64.0°	D4	D3
60°	RH / LH	12°	W-GRIND	35.00"	64.0°	D4	D3
60°	RH / LH	12°	X-GRIND	35.00"	64.0°	D4	D3

JAWS RAW



JAWS RAW WEDGE



WOMEN'S SHAFT: UST RECOIL GRAPHITE F1



WOMEN'S GRIP: LAMKIN WOMEN'S COMFORT

WOMEN'S SPECS

LOFT	AVAILABILITY	BOUNCE	SOLE	STANDARD LENGTH	LIE	GRAPHITE SWING WEIGHT
52°	RH ONLY	10°	S-GRIND	34.50"	64.0°	C3
52°	RH ONLY	12°	W-GRIND	34.50"	64.0°	C3
56°	RH ONLY	10°	S-GRIND	34.25"	64.0°	C5
56°	RH ONLY	12°	W-GRIND	34.25"	64.0°	C5
60°	RH ONLY	12°	W-GRIND	34.00"	64.0°	C5
60°	RH ONLY	10°	S-GRIND	34.00"	64.0°	C5

JAWS

FULL TOE.



JAWS FULL TOE WEDGE

JAWS Full Toe wedges combine full face JAWS grooves, offset groove-in-groove technology and an all-new raw face, giving you the spin and control you need to pull off every shot around the greens.

EVERY SHOT IN FULL CONTROL



CONFIDENCE & VERSATILITY

The Full Toe shape provides more face area with an enhanced toe peak. The shaping works with the specialized C-Grind to make short shots around the green easy to hit, especially bunker shots and high flops. This wedge is built to perform on mid and full wedge shots too, with great turf interaction so you can stick it close.



CONTROLLED TRAJECTORY

The JAWS Toe Pad pushes the CG higher, for a design that creates a lower, more controlled trajectory. Our Variable Weight Port System helps us locate the CG away from the heel, for solid contact and enhanced feel.



AVAILABLE IN RAW FACE CHROME AND RAW BLACK

JAWS

FULL TOE



JAWS FULL TOE WEDGE



GRAPHITE: PROJECT X CATALYST
80g



STEEL: TRUE TEMPER DYNAMIC GOLD SPINNER
115g



GRIP: LAMKIN UTX CHARCOAL GRIP

SPECS

LOFT	AVAILABILITY	BOUNCE	SOLE	STANDARD LENGTH	LIE	STEEL SWING WEIGHT	GRAPHITE SWING WEIGHT
54°	RH / LH	12°	C-GRIND	35.25"	64.0°	D3	D2
56°	RH / LH	12°	C-GRIND	35.25"	64.0°	D3	D2
58°	RH / LH	10°	C-GRIND	35.00"	64.0°	D3	D2
60°	RH / LH	10°	C-GRIND	35.00"	64.0°	D3	D2
64°	RH / LH	10°	C-GRIND	35.00"	64.0°	D3	D2



07

PACKAGED SETS



XR Complete Set

The Callaway XR Packaged Golf Set is packed with ball speed technologies to deliver long distance and complete course coverage through the bag.

PREMIUM CALLAWAY PACKAGE SET

460CC TITANIUM DRIVER FOR LONG DISTANCE

Designed to help you hit your longest drives, along with a high-speed R*MOTO Face.

FAIRWAY WOODS WITH SPEED AND FORGIVENESS

Hyper Face Channel promotes faster ball speeds and helps add distance on off-center hits.

VERSATILE HYBRIDS

Hyper Face Channel for ball speed across the face. They're a great alternative to long irons.

EASY-TO-HIT DISTANCE IRONS

Hyper Face Channel promotes faster ball speeds and helps add distance on off-center hits.

CALLAWAY WEDGES FOR SHORT GAME SHOTS

Our wedges are built for better shots and more confidence around the green.

ODYSSEY DFX PUTTER FOR MORE CONFIDENCE ON THE GREENS

Hyper Face Channel promotes faster ball speeds and helps add distance on off-center hits.

FULL COURSE COVERAGE AND CALLAWAY STAND BAG

Our wedges are built for better shots and more confidence around the green.





XR Complete Set

The Callaway XR Packaged Golf Set is packed with ball speed technologies to deliver long distance and complete course coverage through the bag.

PREMIUM CALLAWAY PACKAGE SET

MODEL	LOFT	LIE	LENGTH
DRIVER	10°	59°	45.5"
3W	16°	60°	43"
4H	21°	61°	40"
5i	23°	61.5°	39.375"
6i	26°	62°	37.625"
7i	30°	62.5°	37"
8i	34.5°	63°	36.5"
9i	39°	63.5°	36"
PW	44°	64°	35.5"
AW	50	64	35.25"
SW	55°	64°	35"
PT	3°	70°	35"

Xj



XJ Junior Set

- Level 3 (7-Piece Set)**
Driver, Fairway Wood, Hybrid, 7i, 9i, SW, Putter
- Level 2 (6-Piece Set)**
Driver, Fairway Wood, 7i, 9i, SW, Putter
- Level 1 (4-Piece Set)**
Fairway Wood, 7i, SW, Putter

Stand Bag and Headcovers Included with Each Set

PERFORMANCE FIT FOR YOUR JUNIOR PLAYER

- LEADING PERFORMANCE TECHNOLOGIES**
 Xj Sets feature our industry-leading Callaway technologies that are designed for the distance to hit it long and the forgiveness to make clean contact and hit solid shots. This includes titanium drivers for long distance and proven graphite shafts.
- ULTRA-LIGHT CLUBS**
 These ultra-light weight sets are engineered so that each club is easy to swing for the best performance.
- THE RIGHT SET FOR EACH JUNIOR PLAYER**
 The Xj line is specifically designed to provide the best junior equipment for players from 42" in Xj1 to 57" in Xj3.



WHITE



BLUE

(Level 3 Sets pictured)

XJ



XJ Junior Set

Level 3 (7-Piece Set)

Driver, Fairway Wood, Hybrid, 7i, 9i, SW, Putter

Level 2 (6-Piece Set)

Driver, Fairway Wood, 7i, 9i, SW, Putter

Level 1 (4-Piece Set)

Fairway Wood, 7i, SW, Putter

Stand Bag and Headcovers Included with Each Set

PERFORMANCE FIT FOR YOUR JUNIOR PLAYER

SET LEVEL	NAME	LOFT	STANDARD LENGTH	LIE	HEAD WEIGHT
LEVEL 1	FAIRWAY WOOD	23°	29.00"	57.0°	200
LEVEL 1	7-IRON	36°	27.00"	60.0°	235
LEVEL 1	SW	52°	25.00"	62.0°	260
LEVEL 1	PUTTER	3°	24.00"	70.0°	300
LEVEL 2	DRIVER	17°	34.00"	56.0°	190
LEVEL 2	FAIRWAY WOOD	23°	33.00"	57.0°	200
LEVEL 2	7-IRON	36°	30.00"	60.0°	235
LEVEL 2	9-IRON	42°	29.00"	61.0°	250
LEVEL 2	SW	52°	28.00"	62.0°	265
LEVEL 2	PUTTER	3°	27.00"	70.0°	300
LEVEL 3	DRIVER	17°	39.00"	56.0°	190
LEVEL 3	FAIRWAY WOOD	23°	37.00"	57.0°	200
LEVEL 3	HYBRID	27°	35.00"	58.0°	205
LEVEL 3	7-IRON	36°	33.00"	60.0°	235
LEVEL 3	9-IRON	42°	32.00"	61.0°	250
LEVEL 3	SW	52°	31.00"	62.0°	265
LEVEL 3	PUTTER	3°	30.00"	70.0°	330

xt



XT Teen Set

Callaway XT Sets are perfect for juniors who want to take their performance to the next level, with industry-leading Callaway technologies designed to help them add distance, hit their best shots, and shoot their best scores.

For Maturing Golfers Who Want To Take Their Performance to the Next Level



DESIGNED FOR IMPROVED DISTANCE AND PERFORMANCE

Featuring a Titanium Driver and graphite shafts, this set is specifically engineered with premium Callaway technologies to deliver more distance off every club, with the forgiveness to hit the ball solid every time. It's a combination built for their longest shots off the tee and their best shots into the green, so they can shoot their lowest scores ever.



COMPLETE COURSE COVERAGE

With a driver, fairway wood, hybrid, 4 irons, 2 wedges, and a putter this is a complete set will full course coverage. They'll have confidence knowing that they have the right club for every shot.



WHITE

xt



XT Teen Set

Callaway XT Sets are perfect for juniors who want to take their performance to the next level, with industry-leading Callaway technologies designed to help them add distance, hit their best shots, and shoot their best scores.

For Maturing Golfers Who Want To Take Their Performance to the Next Level

NAME	LOFT	STANDARD LENGTH	LIE	HEAD WEIGHT
DRIVER	14°	43.50"	56.0°	194
FAIRWAY WOOD	19°	40.50"	57.0°	202
HYBRID	27°	38.50"	58.0°	225
6-IRON	32°	36.50"	60.5°	244
7-IRON	36°	36.00"	61.0°	250
8-IRON	40°	35.50"	61.5°	256
9-IRON	44°	35.00"	62.0°	262
PW	48°	34.50"	62.5°	268
SW	56°	34.30"	63.0°	274
PUTTER	3°	33.00"	70.0°	330

REVA



BLACK

BLUE

ROSE GOLD

REVA COMPLETE SET

The REVA Complete Set from Callaway, the #1 brand for women's equipment, is designed with premium performance in mind. This complete offering is engineered for women of all skill levels who want to increase their distance, hit great shots, and enjoy the game more than ever before.

A PREMIUM PERFORMANCE SET FOR WOMEN



LONG DISTANCE OFF THE DRIVER

Designed for the ultimate combination of distance and forgiveness to inspire confidence in every swing.



EASY TO LAUNCH FAIRWAY WOOD

Optimized so that it's easy to hit with a high flying ball flight.



MAXIMUM FORGIVENESS IN THE IRONS

Large, oversized Deep Cavity back Irons designed for easy launch and forgiveness on mishits.



DESIGNED FOR WOMEN'S SWING SPEED

The loft progressions and set makeup are built based on extensive player testing with women's golfers.



TOUR-PROVEN STROKE LAB PUTTER

Features our innovative Stroke Lab shaft to improve the tempo and consistency in your stroke.



GOLF BAG AND HEADCOVERS

Our premium and functional REVA golf bag and headcovers complete the set.



COLOR OPTIONS

Right-handed sets: Available in red, blue and black. Left-handed sets: Only available in black.

REVA



BLACK



BLUE



ROSE GOLD

REVA COMPLETE SET

11 PIECE SET

Includes: Driver, 3W, 5H, 6H, 7IR-PW, Putter and Bag

8 PIECE SET

Includes: Driver, 5W, 5H, 7I, 9IR, SW, Putter and Bag



CALLAWAY REVA WOMENS SHAFT

SPECS

NAME	LOFT	AVAILABILITY	LENGTH	LIE	SWING WEIGHT
DRIVER	12.5°	RH/LH (BLACK SETS), RH ONLY (BLUE SETS)	44.50"	57.0°	C5
3-WOOD	20°	RH/LH (BLACK SETS), RH ONLY (BLUE SETS)	41.00"	57.5°	C4
5H	27°	RH/LH (BLACK SETS), RH ONLY (BLUE SETS)	38.50"	59.5°	C5
6H	30°	RH/LH (BLACK SETS), RH ONLY (BLUE SETS)	37.50"	60.5°	C5
7-IRON	33°	RH/LH (BLACK SETS), RH ONLY (BLUE SETS)	36.50"	62.5°	C6
8-IRON	38°	RH/LH (BLACK SETS), RH ONLY (BLUE SETS)	36.00"	63.0°	C6
9-IRON	43°	RH/LH (BLACK SETS), RH ONLY (BLUE SETS)	35.50"	63.5°	C6
PW	48°	RH/LH (BLACK SETS), RH ONLY (BLUE SETS)	35.00"	64.0°	C6
SW	56°	RH/LH (BLACK SETS), RH ONLY (BLUE SETS)	34.75"	64.0°	C7



08

GOLF BALL

CHROME SOFT®



Chrome Soft is better for everyone, from amateurs to major winners. Now with our proprietary new Precision Technology, the Chrome Soft Golf Ball is longer through the bag while providing the signature soft feel that golfers love.



TRIPLE TRACK TECHNOLOGY



TRUVIS TECHNOLOGY



PRECISION TECHNOLOGY

New Precision Technology delivers our tightest dispersion, consistently fast ball speeds and total performance.



CONSTRUCTION OPTIMIZATION

New Hyper Elastic SoftFast Core for Tour level speed, spin, and control through the bag.



NEW TOUR AERO

Consistent ball flight at every condition without Tour Aero design.

	FEEL	FORGIVENESS	LONG GAME SPIN	SHORT GAME SPIN
CHROME SOFT	SOFTER	BEST	LOW	HIGH
CHROME SOFT X	SOFT	HIGH	LOW	HIGH
CHROME SOFT X LS	SOFT	HIGH	LOWER	HIGH



WHITE



TRIPLE TRACK WHITE



TRIPLE TRACK YELLOW



TRUVIS WHITE/RED



TRUVIS YELLOW/BLACK

CHROME SOFT X.



Chrome Soft is better for everyone, from amateurs to major winners. Now with our proprietary new Precision Technology, the Chrome Soft X Ball is faster off the driver with a spin profile that's optimized for Tour pros and better players.



TRIPLE TRACK TECHNOLOGY



PRECISION TECHNOLOGY

New Precision Technology delivers our tightest dispersion, consistently fast ball speeds and total performance. We've enhanced every component and design feature to create the highest quality golf balls.



CONSTRUCTION OPTIMIZATION

New Hyper Elastic SoftFast Core for Tour level speed, spin, and control through the bag.



NEW TOUR AERO

Consistent ball flight at every condition with our Tour Aero design.

	FEEL	FORGIVENESS	LONG GAME SPIN	SHORT GAME SPIN
CHROME SOFT	SOFTER	BEST	LOW	HIGH
CHROME SOFT X	SOFT	HIGH	LOW	HIGH
CHROME SOFT X LS	SOFT	HIGH	LOWER	HIGH



WHITE



TRIPLE TRACK WHITE



TRIPLE TRACK YELLOW

CHROME SOFT X^{LS}



Chrome Soft is better for everyone, from amateurs to major winners. Now with our proprietary new Precision Technology, the Chrome Soft X LS Golf Ball is faster off the driver with a new cover for more greenside control.



TRIPLE TRACK TECHNOLOGY



PRECISION TECHNOLOGY

New Precision Technology delivers our tightest dispersion, consistently fast ball speeds and total performance. We've enhanced every component and design feature to create the highest quality golf balls.



CONSTRUCTION OPTIMIZATION

New Hyper Elastic SoftFast Core for increased driver speed and increased greenside spin while maintaining soft feel.



NEW TOUR AERO

Penetrating ball flight and lower drag with new Tour Aero.

	FEEL	FORGIVENESS	LONG GAME SPIN	SHORT GAME SPIN
CHROME SOFT	SOFTER	BEST	LOW	HIGH
CHROME SOFT X	SOFT	HIGH	LOW	HIGH
CHROME SOFT X LS	SOFT	HIGH	LOWER	HIGH



WHITE



TRIPLE TRACK WHITE



TRIPLE TRACK YELLOW





E·R·C SOFT.



ERC Soft is our longest golf ball with soft feel, and for 2023 we've introduced technologies that promote a new level of complete performance. Leading with the cover, we've created an all-new GRIP Urethane Coating System that provides even more greenside spin. The unique cover is paired with an all-new HyperElastic SoftFast core that increase ball speed, while maintaining soft feel through the bag.

These new technologies properly complement each other, delivering soft feel through the bag, incredible distance with the driver, and added spin for greenside control with your wedges.

OUR LONGEST BALL WITH SOFT FEEL AND GREENSIDE CONTROL

- 
NEW GRIP URETHANE COATING FOR INCREASED GREENSIDE SPIN
 This coating system features high-elongation paint for increased control on approach shots and short game shots.
- 
MORE BALL SPEED & SOFT FEEL FROM NEW HYPER ELASTIC SOFTFAST CORE
 Optimized for faster driver speed and soft feel around the green.
- 
HYBRID COVER PROVIDES EXCEPTIONAL FEEL, CONTROL AND SPIN + LONG DISTANCE
 The cover allows us to create a versatile, multi-material construction. This is how we combine maximized distance from high launch and low spin, with soft feel and durability.
- 
HIGH SPEED MANTLE FOR ENHANCED BALL SPEED AND CONTROL
 Creates more efficient energy transfer between the layers for more ball speed and provides more wedge spin around the green.
- 
NEW TRIPLE TRACK DAGGER TECHNOLOGY FOR ADVANCED ALIGNMENT
 Our new Triple Track Dagger lines are prominently featured on ERC Soft to help you find the right alignment for every putt.



WHITE



YELLOW





E·R·C SOFT REVA™



ERC Soft is our longest golf ball with soft feel, and for 2023 we've introduced technologies that promote a new level of complete performance. Leading with the cover, we've created an all-new GRIP Urethane Coating System that provides even more greenside spin. The unique cover is paired with an all-new HyperElastic SoftFast core that increase ball speed, while maintaining soft feel through the bag.

These enhanced design features are especially suited for women who want to optimize their performance on the course. Our new technologies properly complement each other, delivering soft feel through the bag, incredible distance with the driver, and added spin for greenside control with your wedges.

OUR LONGEST BALL WITH SOFT FEEL AND GREENSIDE CONTROL

- 
NEW GRIP URETHANE COATING FOR INCREASED GREENSIDE SPIN
 This coating system features high-elongation paint for increased control on approach shots and short game shots.
- 
MORE BALL SPEED & SOFT FEEL FROM NEW HYPER ELASTIC SOFTFAST CORE
 Optimized for faster driver speed and soft feel around the green.
- 
HYBRID COVER PROVIDES EXCEPTIONAL FEEL, CONTROL AND SPIN + LONG DISTANCE
 The cover allows us to create a versatile, multi-material construction. This is how we combine maximized distance from high launch and low spin, with soft feel and durability.
- 
HIGH SPEED MANTLE FOR ENHANCED BALL SPEED AND CONTROL
 Creates more efficient energy transfer between the layers for more ball speed and provides more wedge spin around the green.
- 
NEW TRIPLE TRACK DAGGER TECHNOLOGY FOR ADVANCED ALIGNMENT
 Our new Triple Track Dagger lines are prominently featured on ERC Soft to help you find the right alignment for every putt.





WHITE

REVA



The Callaway REVA Golf Ball is engineered for women who want to improve their distance, ball flight and consistency. To promote easy launch and more forgiveness, we've leveraged an oversized construction that conforms to the rules of golf. Our oversized core and low spin characteristics are also designed for longer, more accurate shots. Try the REVA if you're looking to hit better shots that fly on a straighter line.

DESIGNED FOR WOMEN TO UNLOCK YOUR DISTANCE

- 
EASY TO LAUNCH AND MORE FORGIVING
 Promotes higher ball flight for increased distance, and more forgiveness for better accuracy, all from an oversized construction that conforms to the rules of golf.
- 
LONG AND STRAIGHT
 Our oversized core and low spin profile are specifically designed for women to maximize distance and consistency on the course.



WHITE





PINK

SUPERSOFT™



SUPER LONG. SUPER STRAIGHT. SUPER SOFT FEEL.

- 
INCREASED BALL SPEED WITH SOFT FEEL FROM OUR HYPERELASTIC SOFTFAST CORE
 Optimized for faster speed and soft feel around the green.

- 
EXCEPTIONAL FEEL, CONTROL AND SPIN WITH LONG DISTANCE FROM OUR HYBRID COVER
 Allow us to create more wedge control while still maximizing distance, very soft feel and durability.

Supersoft is one of the most popular balls in golf, particularly for its long, straight distance, and most importantly the super soft feel. We've advanced the cover, core, and construction technologies to enhance these key benefits, with improved performance from tee-to-green.

Our HyperElastic SoftFast Core increases ball speed, especially off the driver, while creating soft feel off your irons and around the green. The multi-material construction and dynamic Hybrid Cover also promote long distance, along with exceptional spin, outstanding feel, and short game control. The new softer cover system is engineered for even more greenside spin. Players love this ball, and now it's even better throughout the bag.



WHITE



YELLOW



MATTE PINK



MATTE ORANGE



MATTE RED



MATTE GREEN

WARBIRD



Callaway's Warbird is a distance ball that creates maximum speed from a large high energy core, and a 2-piece construction. This design promotes high launch and long carry from our HEX Aerodynamics, with impressive feel and control to complement all that distance. Try the Warbird if you're looking to add distance to your game.

DESIGNED FOR DISTANCE



LONG DISTANCE

Warbird is built for maximum ball speed off of every club. The extra-large, high-energy core is highly compressible so you can unlock more potential distance.



HIGH LAUNCH & LONG CARRY

HEX Aerodynamics reduces drag and promotes increased launch for more speed, better ball flight and more distance.



SUPREME FEEL & CONTROL

The optimized ionomer cover and large core provide feel and greenside control from a 2-piece design.



WHITE OFFERED IN 12 & 15 BALL PACKAGE



YELLOW OFFERED IN 12 BALL PACKAGE



09

ODYSSEY

ELEVEN



The Eleven shape advances the forgiveness and alignment properties of our major-winning Ten model. It helps you properly frame the ball at address and delivers a forward CG with high MOI for better accuracy.



RED STROKE LAB SHAFT



PISTOL AND OS GRIPS

Reshaping the Mallet. Redefining Performance.

Red Stroke Lab Shaft

Our Tour proven multi-material Stroke Lab shaft reduces inconsistencies in your stroke and improves overall performance. Stroke Lab shafts are a staple in professional golf, with wins across all global Tours.

Forward CG & High Inertia

Using a multi-material design, we've moved the CG forward nearly half an inch while increasing inertia substantially. This creates improved performance, speed control, and spin control, on off-center hits for a much tighter downrange dispersion. The forward CG also allows this mallet to swing more like a blade during the stroke.

Super lightweight TPU Sole Insert

Helps improve the sound and feel, while adding very little weight to the center of the putter head.

White Hot Insert

Our most popular putter insert of all time is back with the original formulation, feel, sound, and performance.



Model	Hosel	RH	LH	Loft	Lie	Length	Offset	Toe Hang	Headweight
ELEVEN TOUR LINED	S	Yes	Yes	3	70	33 34 35	¼ Shaft	40	365
ELEVEN TOUR LINED	DB	Yes	Yes	3	70	33 34 35	Full Shaft	10	365
ELEVEN TOUR LINED	CS	Yes	No	3	70	33 34 35	Zero	0	365
2BALL ELEVEN	S	Yes	No	3	70	33 34 35	¼ Shaft	40	365
2BALL ELEVEN	DB	Yes	No	3	70	33 34 35	Full Shaft	10	365
2BALL ELEVEN TOUR LINED	S	Yes	Yes	3	70	33 34 35	¼ Shaft	40	365
2BALL ELEVEN TOUR LINED	DB	Yes	Yes	3	70	33 34 35	Full Shaft	10	365
2BALL ELEVEN TOUR LINED	CH	Yes	No	3	70	33 34 35	Full Shaft	20	365
2BALL ELEVEN TRIPLE TRACK	DB	Yes	No	3	70	33 34 35	Full Shaft	10	365

TRI-HOT 5K



Tri-Hot 5K is built to improve performance by reducing the amount of side spin on off-center hits. We achieve this through a multi-material design using stainless steel and tungsten in the front and lightweight milled aluminum in the rear. This technique moves the the CG forward while increasing inertia. This keeps putts closer to the original line, with tighter dispersion, and a greater chance to go in on less-than-perfect strikes.



RED STROKE LAB SHAFT



PISTOL GRIPS

A Blade Unlike Any Other

Unprecedented Forgiveness For A Blade and Improved Roll From Tungsten Front Weights

We've precisely positioned massive amounts of tungsten (up to 120 grams) behind the face in the toe and heel sections of the club head. The CG is moved forward for improved roll, while also increasing inertia to over 5,000 IZZ. It's a level of forgiveness that you've never seen before in a standard size blade putter, and now it's offered in standard sized mallets.

Interchangeable Front Weights

Available in aluminum, steel and tungsten, these removable weights allow you to dial in your head weight to your exact preference.

Legendary White Hot insert

The most popular insert of all time is back with the original formulation, feel, sound, and performance.

Red Stroke Lab Shaft

The newest generation of our proven multi-material Stroke Lab shaft features even better performance. You've probably seen the world's best players use it on TV, especially on Sunday afternoons! By shortening the steel section, we reduced the weight by seven grams compared to the original Stroke Lab. We also made it stiffer and more stable for even more consistency in your stroke and your performance.



ONE TWO THREE



DOUBLE WIDE (DB, CH) TRIPLE WIDE (DB, CS)

Model	Hosel	RH	LH	Loft	Lie	Length	Offset	Toe Hang	Headweight
ONE	CH	Yes	Yes	3	70	33 34 35	Full Shaft	52	360
TWO	CH	Yes	No	3	70	33 34 35	Full Shaft	50	360
THREE	F	Yes	No	3	70	33 34 35	Half Shaft	70	360
DOUBLE WIDE	DB	Yes	No	3	70	33 34 35	Full Shaft	20	360
DOUBLE WIDE	CH	Yes	Yes	3	70	33 34 35	Full Shaft	42	365
TRIPLE WIDE	DB	Yes	No	3	70	33 34 35	Full Shaft	0	365
TRIPLE WIDE	CS	Yes	No	3	70	33 34 35	Zero	0	360

TRI-HOT 5K



Tri-Hot 5K is built to improve performance by reducing the amount of side spin on off-center hits. We achieve this through a 303 stainless steel front section that includes the hosel and face area. This material has been finish milled to exact shape and weight, helping to keep the CG forward. This keeps putts closer to the original line, with tighter dispersion, and a greater chance to go in on less-than-perfect strikes.



RED STROKE LAB SHAFT



PISTOL GRIPS

5K Mallets – Feel Meets Forgiveness

Incredible Forgiveness and Improved Roll From Tungsten Front Weights

We've precisely positioned massive amounts of tungsten (up to 120 grams) behind the face in the toe and heel sections of the club head. The CG is moved forward for improved roll, while also increasing inertia to over 5,000 IZZ. It's a level of forgiveness that you've never seen before in a standard size blade putter, and now it's offered in standard sized mallets.

Interchangeable Front Weights

Available in 5, 10, 15 and 20 grams these removable weights allow you to dial in your head weight to your exact preference.

Legendary White Hot insert

The most popular insert of all time is back with the original formulation, feel, sound, and performance.

Red Stroke Lab Shaft

The newest generation of our proven multi-material Stroke Lab shaft features even better performance. Our Stroke Lab shafts are a staple in professional golf with wins across all global Tours.

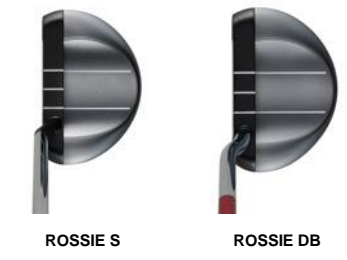

Model	Hosel	RH	LH	Loft	Lie	Length	Offset	Toe Hang	Headweight
SEVEN	S	Yes	No	3	70	33 34 35	¾ Shaft	44	365
SEVEN	DB	Yes	Yes	3	70	33 34 35	Full Shaft	0	365
SEVEN	CH	Yes	No	3	70	33 34 35	Full Shaft	19	365
ROSSIE	S	Yes	No	3	70	33 34 35	¾ Shaft	50	365
ROSSIE	DB	Yes	No	3	70	33 34 35	Full Shaft	0	365

WHITE HOT VERSA

Now alignment is as simple as black and white

Versa Alignment

This proven, major winning Versa technology has dominated on Tours all over the world. The black and white high contrast alignment system helps golfers with their alignment at address and through your stroke. It highlights the proper face angle and improving concentration, so you make more putts.

White Hot Insert

The original White Hot formulation creates incredible feel, sound, and performance in one exceptional two-part urethane insert. Versa and the iconic White Hot insert are long time favorites of tour players and golfers alike. They've been asking for us to bring these technologies back and we've listened.

Red Stroke Lab Shaft

The newest generation of our proven multi-material Stroke Lab shaft features even better performance. By shortening the steel section, we reduced the weight by seven grams over the previous generation Stroke Lab. We also made it stiffer and more stable for even more consistency in your stroke and your performance.



Model	Hosel	RH	LH	Loft	Lie	Length	Offset	Toe Hang	Headweight
ONE CH	CH	Yes	Yes	3	70	33 34 35	Full Shaft	45	360
DOUBLE WIDE	DB	Yes	No	3	70	33 34 35	Full Shaft	20	360
THREE T	S	Yes	No	3	70	33 34 35	¾ Shaft	43	365
SEVEN	S	Yes	No	3	70	33 34 35	¾ Shaft	43	365
SEVEN	DB	Yes	Yes	3	70	33 34 35	Full Shaft	0	365
TWELVE	S	Yes	Yes	3	70	33 34 35	¾ Shaft	36	365
TWELVE	DB	Yes	Yes	3	70	33 34 35	Full Shaft	0	365
TWELVE	CS	Yes	No	3	70	33 34 35	Zero	0	365

Alignment is one of the most essential variables in putting, yet it's often overlooked. On a ten-foot putt, one degree off line is the difference between a make and a miss. Many of the best putting minds in the game have told us how critical Versa is to performance, including Tour Pros and world-renowned instructor Phil Kenyon. They know this technology works, and they've strongly encouraged us to bring this design to golfers in a reimagined profile.



RED STROKE LAB SHAFT



PISTOL GRIPS

WHITE HOT OG

WOMEN'S



Legendary Then, Iconic Now

White Hot Insert

The original White Hot formulation, feel, sound and performance are all back in one exceptional two-part urethane insert. Tour players and golfers alike have been asking us to re-introduce it for years, and we've listened.

Milled Surface Finish

Our engineers have combined a rich silver PVD finish with fine milling on all key surfaces. These ultra-premium offerings are unlike anything you've ever seen from a White Hot, and the beautiful designs will appeal to golfers who appreciate the look of a milled putter.

High Performance Shafts and New Grips

Available in a premium steel shaft or our Tour proven, multi-material Stroke Lab shaft in a new pearl white. Both shaft options are precisely fitted in shorter lengths of 32" & 33" with our new slim pistol grip that's specifically designed for women.



The original White Hot formulation, feel, sound and performance are all back in one exceptional two-part urethane insert



WOMENS STEEL SHAFT



GRIPS

Model	Hosel	RH	LH	Loft	Lie	Length	Offset	Toe Hang	Headweight
1	CH	Yes	No	3	70	33 34 35	Full Shaft	41	350
7	S	Yes	No	3	70	33 34 35	¾ Shaft	40	350
2-BALL	DB	Yes	No	3	70	33 34 35	Full Shaft	0	355

WHITE HOT | OG



Legendary Then, Iconic Now

White Hot Insert

The most popular putter insert of all time is back with the original formulation, feel, sound, and performance. When Tour players and recreational golfers asked us to re-introduce it, we listened.

Milled Surface Finish

A rich silver PVD finish, combined with fine milling on the surfaces, gives these putters an ultra-premium look, unlike any White Hot you've seen. They're beautiful and will appeal to golfers that appreciate the look of a milled design.

High Performance Shafts with New Pistol Grip

Available in a premium steel shaft or our red Stroke Lab shaft; both options are fitted with a New Pistol Grip. We've made Stroke Lab stiffer and more stable for even more consistency in your stroke, and your performance. It's winning major championships and dominating at the world's biggest events.

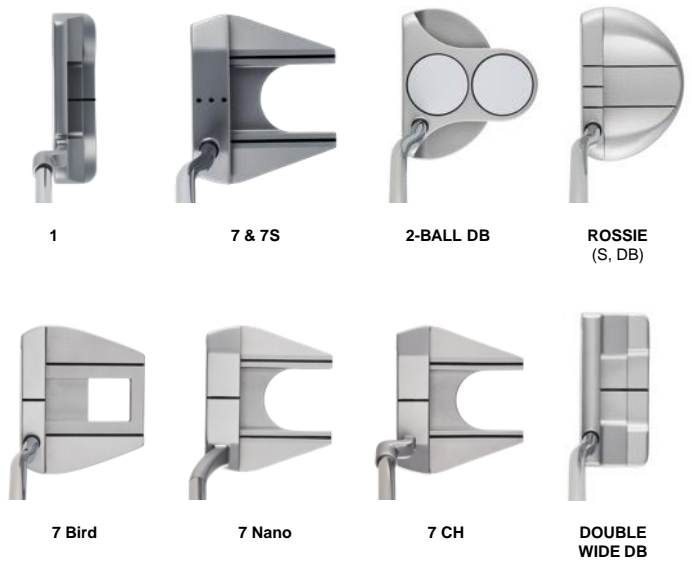

Model	Hosel	RH	LH	Loft	Lie	Length	Offset	Toe Hang	Headweight
1	CH	Yes	Yes	3	70	33 34 35	Full Shaft	41	350/360
7	DB	Yes	Yes	3	70	33 34 35	Full Shaft	0	355/365
7 S	S	Yes	No	3	70	33 34 35	¾ Shaft	40	355/365
2-BALL	DB	Yes	Yes	3	70	33 34 35	Full Shaft	0	355/365
ROSSIE	DB	Yes	No	3	70	33 34 35	Full Shaft	0	355/365
ROSSIE S	S	Yes	No	3	70	33 34 35	¾ Shaft	36	355/365
7 Bird	DB	Yes	No	3	70	33 34 35	Full Shaft	0	355/365
7 Nano	F	Yes	Yes	3	70	33 34 35	¾ Shaft	40	355/365
7 CH	CH	Yes	No	3	70	33 34 35	Full Shaft	20	355/365
Double Wide	DB	Yes	Yes	3	70	33 34 35	Full Shaft	0	350/360

The original White Hot formulation, feel, sound and performance are all back in one exceptional two-part urethane insert.



STROKE LAB SHAFT



GRIPS



10

CUSTOM LOGO

Customs

CARLSBAD • CA



CUSTOM TRUVIS GOLF BALL

The Chrome Soft Truvis golf ball allows golfers to personalize the Truvis design/technology with a logo inside the Truvis pattern. These golf balls provide a great opportunity for a unique offering not available on any other golf ball in the market.

MINIMUM ORDER: 48 dozen

PRODUCTION LEAD TIME: 15 business days from logo approval

PLAYER NUMBER: One player number (up to four digits) per order

COLOR OPTIONS:

 BLACK	 GREY PMS CG9	 SKY PMS 299	 LIGHTER BLUE PMS 3005	 ROYAL IN-LINE BLUE PMS 2945	 DARK BLUE PMS 294
 NIGHT BLUE PMS 2955	 LIGHT TURQUOISE PMS 3255	 TURQUOISE PMS 3125	 CYAN PMS 3135	 PURPLE PMS 2091	 EGGPLANT PMS 281
 PINK PMS 232	 TAFFY PMS 702	 RED PMS 186	 MAROON PMS 697	 WINE RED PMS 187	 SUN YELLOW PMS 7548
 YELLOW PMS 137	 ORANGE PMS 165	 GINGER PMS 158	 SANDSTONE PMS 7565	 BURNT ORANGE PMS 1525	 LIME GREEN PMS 376
 VINE GREEN PMS 362	 GREEN PMS 347	 DARK GREEN PMS 357	 MEDIUM IN-LINE GREEN PMS 561	 DEEP BROWN PMS 2322	 DARK BROWN PMS 7532
 MEDIUM GOLD PMS 132	 METALLIC GOLD PMS 8383				

JAWS RAW™

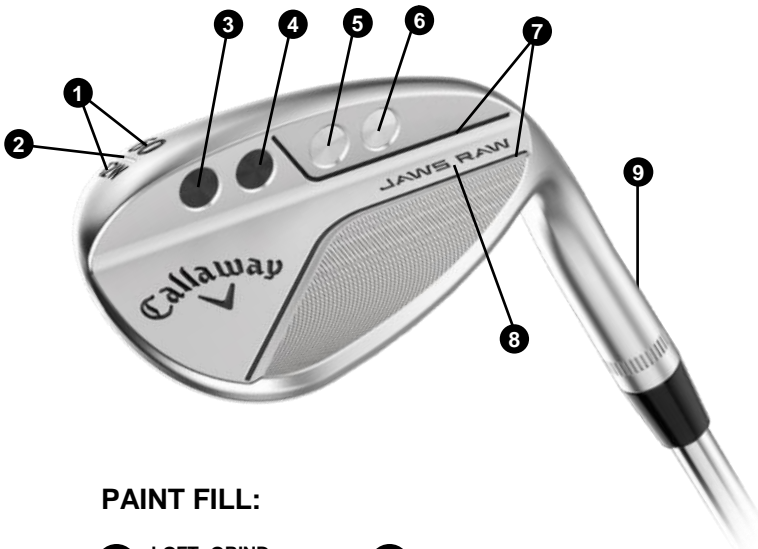

PAINT FILL:

- 1** LOFT, GRIND & BOUNCE
- 2** UNDERScore
- 3** PORT 1
- 4** PORT 2
- 5** PORT 3
- 6** PORT 4
- 7** LINE ACCENTS
- 8** JAWS RAW COLOR
- 9** .R. Color

STAMPING:

CHARACTERS AVAILABLE

- Alphabet: **A to Z**
 - Numerals: **0 to 9**
 - Special Characters: **! . # \$? ' : @**
- (A Blank Space is also available as a special character)

BASIC STAMPING

- Three Letter

ADVANCED STAMPING

- Straight Toe
- Straight
- Freehand Toe
- Freehand
- Scatter Initials
- Scatter Symbol
- Scatter Both

PAINT COLORS:

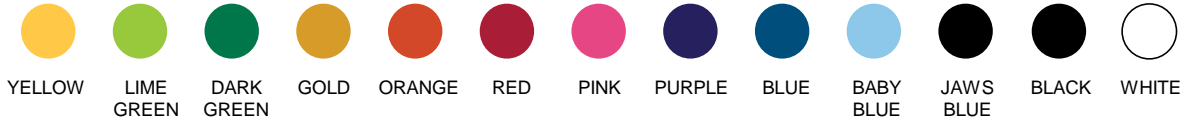

MEDALLION COLORS: *STOCK MEDALLIONS ALSO AVAILABLE VIA CUSTOMS

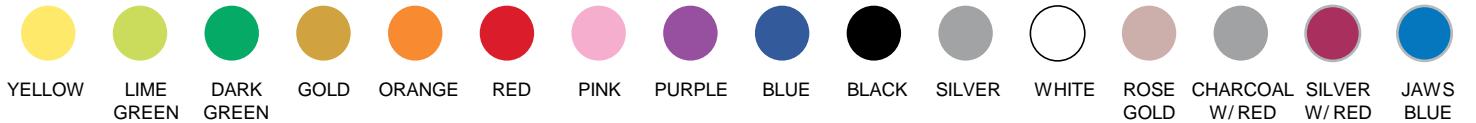

Basic Stamping – Three Letter



Advanced Stamping – Straight Toe



Advanced Stamping – Straight



Advanced Stamping – Freehand Toe



Advanced Stamping – Freehand



Advanced Stamping – Scatter Initials



Advanced Stamping – Scatter Symbol



Advanced Stamping – Scatter Both

JAWS

FULL TOE.



PAINT FILL:



- 1 LOFT AND BOUNCE
- 2 LINE COLOR 2
- 3 MEDALLION 1
- 4 MEDALLION 2
- 5 MEDALLION 3
- 6 MEDALLION 4
- 7 JAWS Color
- 8 FULL TOE Color
- 9 .R. Color

STAMPING:

CHARACTERS AVAILABLE

- Alphabet: **A to Z**
- Numerals: **0 to 9**
- Special Characters: **! . # \$? ' : @**
(A Blank Space is also available as a special character)

ADVANCED STAMPING

- Straight (9 Characters)
- Freehand (9 Characters)
- Straight Initials (3 Characters)
- Freehand Initials (3 Characters)
- Initials Scattered (2 Characters)
- Symbol Scatter (1 Symbol) 
- Scattered Initials & Symbols (2 Characters plus 1 Symbol) 

PAINT COLORS:



MEDALLION COLORS: *STOCK MEDALLIONS ALSO AVAILABLE VIA CUSTOMS

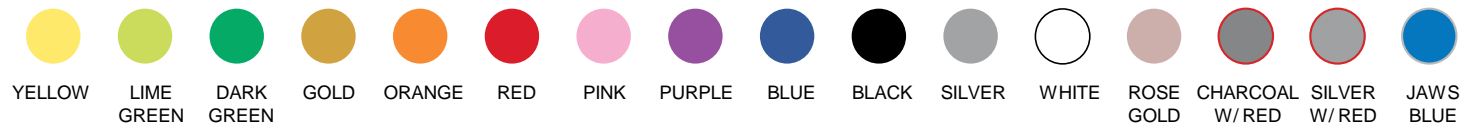

Advanced Stamping - Straight



Advanced Stamping - Freehand



Advanced Stamping - Straight Initials



Advanced Stamping - Freehand Initials



Advanced Stamping - Initials Scattered



Advanced Stamping - Symbol Scatter



Advanced Stamping - Scatter Initials & Symbol



11

PERFORMANCE GEAR

CALLAWAY PARADYM STAFF BAGS

PARADYM STAFF BAG

The same bag Callaway Tour Professionals are using in 2023. Tour branding, GPS pocket, integrated umbrella sleeve, and two full-length apparel pockets.

- Callaway Tour Branding
- 10", 6-way Top with Velour-wrapped Cuff
- 8 Pockets Including a Velour-lined Valuables Pocket and Rangefinder/GPS Pocket
- Padded OptiFit Comfort Strap* conforms to the shape of your shoulder and doesn't break down over time for long lasting comfort
- Fully Integrated Umbrella Sleeve
- Perfect Balance Base
- Color Matching Rain Hood
- Weight: 11 lbs
- Logo Ready: Belly panel



CALLAWAY PARADYM BAGS



ORG 14



ORG 14 HD



FAIRWAY 14



FAIRWAY 14 HD



FAIRWAY C HD



CHEV 14 DRY



CHEV DRY



FAIRWAY C

CALLAWAY PARADYM HEADWEAR & ACCESSORIES

HEADWEAR



LAUNCH HEADWEAR



WHITE



NAVY



BLACK



TA PERFORMANCE PRO



WHITE/BLACK *



BLACK/WHITE *



NAVY/WHITE



BLACK HEATHER / WHITE *



RED HEATHER / WHITE



LT BLUE

* Available in XL



TA HIGH CROWN VISOR



WHITE



HEATHER



BLACK



WHITE / CARDINAL **



WHITE / GREEN **



WHITE / NAVY **



WHITE / GREY **

** Only available in 12 pack

ACCESSORIES



PARADYM MICROFIBER TOWEL



PARADYM 68" DOUBLE CANOPY UMBRELLA



12

CARRYOVER

ROGUE ST



ROGUE ST MAX

Rogue ST MAX is our highest MOI head with a slight draw bias that's built for all levels of golfers. This is the best combination of distance and forgiveness in a Callaway driver.

OUR FASTEST, MOST STABLE DRIVER EVER



INCREASED SPEED, STABILITY & HIGH MOI FROM ALL-NEW TUNGSTEN SPEED CARTRIDGE

The groundbreaking new Tungsten Speed Cartridge structure places up to 26 grams low and deep in the driver head. This increases speed on off-center hits and provides more forgiveness through high MOI.



STABILITY AND SPEED FROM JAILBREAK SPEED FRAME

Our patented A.I. designed Jailbreak Speed Frame provides stability in the horizontal and torsional directions. We've speed tuned the construction, shaping, and positioning to deliver even more speed across the face.



NEW A.I. DESIGNED FACE FOR LOWER SPIN AND INCREASED FORGIVENESS

As the industry leader in Artificial Intelligence, we've added launch and spin to ball speed in our optimization formula. This new formula lowers spin on the face, allowing us to add forgiveness to the driver.



STABILITY AND FORGIVENESS FROM UNIBODY CONSTRUCTION

The titanium unibody construction provides stability and lowers the center of gravity, while our proprietary Triaxial Carbon crown and sole allow us to save weight. This weight is precisely redistributed to increase forgiveness with high launch and a slight draw bias.

ROGUE ST



ROGUE ST MAX



PROJECT X CYPHER

40g (Light, Reg) • 50g (Reg)



MITSUBISHI NEW TENSEI AV BLUE SERIES

50g (Reg, Stiff) • 60g (Reg, Stiff)



MITSUBISHI NEW TENSEI AV White SERIES

60g (Stiff, X-Stiff)

**Shaft weights indicate weight class*



GOLF PRIDE TOUR VELVET 360 (50g)

DRIVER SPECS

MODEL	LOFT	AVAILABILITY	STANDARD LENGTH	LIE	CC	SWING WEIGHT
9°	ADJUSTABLE (8°-11°)	RH / LH	45.75"	60° (ADJUSTABLE)	460	D3 (40/50G)
10.5°	ADJUSTABLE (9.5°-12.5°)	RH / LH	45.75"	60° (ADJUSTABLE)	460	D3 (40/50G)
12°	ADJUSTABLE (11°-14°)	RH / LH	45.75"	60° (ADJUSTABLE)	460	D3 (40/50G)

COMPARISON CHART

	Rogue ST MAX D	Rogue ST MAX	Rogue ST MAX LS	Rogue ST LS
Tungsten Speed Cartridge Structure	20g	26g	23g	20g
Jailbreak AI Speed Frame	Yes	Yes	Yes	Yes
Flash Face SS22	Yes	Yes	Yes	Yes
Weight Screw	Yes	Yes	Yes	
Launch	High	High	Low	Mid
Spin	Mid	Mid	Low	Lowest
Flight Bias	Draw	Semi Draw	Neutral	Neutral
Forgiveness	Highest	Highest	Highest	High

WOMENS
ROGUE
ST



WOMEN'S ROGUE ST MAX

The Rogue ST Max Women's driver features all the core technology of the Rogue ST Max Driver but has been tuned specifically for women with optimized lengths, lighter swingweight, and lighter shaft and grip combination. It's our most forgiving Rogue ST Driver model and is built for mid launch with slight draw bias.

OUR FASTEST, MOST STABLE DRIVER EVER



INCREASED SPEED, STABILITY & HIGH MOI FROM ALL-NEW TUNGSTEN SPEED CARTRIDGE

The groundbreaking new Tungsten Speed Cartridge structure places up to 26 grams low and deep in the driver head. This increases speed on off-center hits and provides more forgiveness through high MOI.



STABILITY AND SPEED FROM JAILBREAK SPEED FRAME

Our patented A.I. designed Jailbreak Speed Frame provides stability in the horizontal and torsional directions. We've speed tuned the construction, shaping, and positioning to deliver even more speed across the face.



NEW A.I. DESIGNED FACE FOR LOWER SPIN AND INCREASED FORGIVENESS

As the industry leader in Artificial Intelligence, we've added launch and spin to ball speed in our optimization formula. This new formula lowers spin on the face, allowing us to add forgiveness to the driver.



STABILITY AND FORGIVENESS FROM UNIBODY CONSTRUCTION

The titanium unibody construction provides stability and lowers the center of gravity, while our proprietary Triaxial Carbon crown and sole allow us to save weight. This weight is precisely redistributed to increase forgiveness with high launch and a slight draw bias.

WOMENS
ROGUE
ST



WOMEN'S ROGUE ST MAX



PROJECT X CYPHER

40g (WMS)

*Shaft weights indicate weight class



WIN DRI-TAC 2.0 (45g)

DRIVER SPECS

MODEL	LOFT	AVAILABILITY	STANDARD LENGTH	LIE	CC	SWING WEIGHT
10.5	ADJUSTABLE (9.5°-12.5°)	RH / LH CUSTOM ONLY	44.50"	59.0° (ADJUSTABLE)	460	C8
12°	ADJUSTABLE (11°-14°)	RH / LH CUSTOM ONLY	44.50"	59.0° (ADJUSTABLE)	460	C8

COMPARISON CHART

	Rogue ST MAX D	Rogue ST MAX	Rogue ST MAX LS	Rogue ST LS
Tungsten Speed Cartridge Structure	20g	26g	23g	20g
Jailbreak AI Speed Frame	Yes	Yes	Yes	Yes
Flash Face SS22	Yes	Yes	Yes	Yes
Weight Screw	Yes	Yes	Yes	
Launch	High	High	Low	Mid
Spin	Mid	Mid	Low	Lowest
Flight Bias	Draw	Semi Draw	Neutral	Neutral
Forgiveness	Highest	Highest	Highest	High

ROGUE
ST**ROGUE ST MAX FAIRWAY**

The Rogue ST MAX model will fit a wide range of players who want speed, forgiveness, and all-around performance. It's a mid-launch offering with slight draw bias. The MAX model features a new progressive shape to appeal to a wide range of golfers. This is our widest Rogue ST offering, featuring models from a 3W through 11W.

OUR FIRST EVER DEDICATED DRAW FAIRWAY WOOD**UP TO 10 YARDS LONGER**

The new A.I.-designed Jailbreak ST with Batwing Technology promotes speed and stability. The two Jailbreak batwings are pushed to the perimeter, providing stiffness while allowing the face to flex for high ball speeds.

**OPTIMAL LAUNCH WITH MORE SPEED FROM THE TUNGSTEN SPEED CARTRIDGE**

We're introducing the groundbreaking Tungsten Speed Cartridge for the first time in a fairway wood. By incorporating up to 27g of this high-density tungsten, the Center of Gravity (CG) is pushed low and forward. The result is lower spin with more ball speed.

**A.I. FACE OPTIMIZED FOR SPEED, LAUNCH AND SPIN**

We've applied an all new A.I. face optimization to include speed, launch and spin. This unique face pattern is customized for each model and loft in the fairway lineup.

**SPEED AND CONSISTENCY FROM A HIGH STRENGTH FACE CUP**

The C300 maraging steel is specially treated through a proprietary process for high strength and flexibility, while the Flash Face Cup provides speed and spin consistency across the face.

ROGUE ST



ROGUE ST MAX FAIRWAY



PROJECT X CYPHER

40g (Light) • 50g (Light, Reg)



MITSUBISHI NEW TENSEI AV BLUE SERIES

60g (Reg, Stiff) • 70g (Reg)



MITSUBISHI NEW TENSEI AV White SERIES

70g (Stiff, X-Stiff)

**Shaft weights indicate weight class*



GOLF PRIDE TOUR VELVET 360 (50g)

FAIRWAY SPECS

NAME	LOFT	AVAILABILITY	STANDARD LENGTH	LIE	CC	SWING WEIGHT
3W	15°	RH / LH	43.25"	56.0°	174	D3 (40/50/60G), D4 (70G WHITE), D5 (70G BLUE)
3 HL	16.5°	RH ONLY	43.25"	56.0°	174	D3 (40/50/60G), D4 (70G WHITE), D5 (70G BLUE)
5W	18°	RH / LH	42.75"	56.5°	148	D3 (40/50/60G), D4 (70G WHITE), D5 (70G BLUE)
HW	20°	RH ONLY	43.00"	57.0°	153	D3 (40/50/60G), D4 (70G WHITE), D5 (70G BLUE)
7W	21°	RH / LH	42.25"	57.0°	139	D3 (40/50/60G), D4 (70G WHITE), D5 (70G BLUE)
9W	24°	RH ONLY	41.75"	58.0°	132	D3 (40/50/60G), D4 (70G WHITE), D5 (70G BLUE)
11W	27°	RH ONLY	41.25"	59.0°	127	D3 (40/50/60G), D4 (70G WHITE), D5 (70G BLUE)

COMPARISON CHART

	Rogue ST MAX D	Rogue ST MAX	Rogue ST MAX LS
Tungsten Speed Cartridge Structure	20g	26g	23g
Jailbreak AI Speed Frame	Yes	Yes	Yes
Flash Face SS22	Yes	Yes	Yes
Weight Screw	Yes	Yes	Yes
Launch	High	High	Low
Spin	Mid	Mid	Low
Flight Bias	Draw	Semi Draw	Neutral
Forgiveness	Highest	Highest	Highest

WOMENS
ROGUE
ST



WMN ROGUE ST MAX FAIRWAY

The Rogue ST Max Women's fairways feature all the core technology of the Rogue ST Max fairway but has been tuned specifically for women with optimized lengths, lighter swingweight, and lighter shaft and grip combination. The Rogue ST Max model features stronger lofts and slightly more open face angle compared to the Max D model. The Max model has the most robust loft offerings, plus unique progressive shaping on the 3 & 5 woods to enhance MOI.

OUR FIRST EVER DEDICATED DRAW FAIRWAY WOOD



UP TO 10 YARDS LONGER

The new A.I.-designed Jailbreak ST with Batwing Technology promotes speed and stability. The two Jailbreak batwings are pushed to the perimeter, providing stiffness while allowing the face to flex for high ball speeds.



OPTIMAL LAUNCH WITH MORE SPEED FROM THE TUNGSTEN SPEED CARTRIDGE

We're introducing the groundbreaking Tungsten Speed Cartridge for the first time in a fairway wood. By incorporating up to 27g of this high-density tungsten, the Center of Gravity (CG) is pushed low and forward. The result is lower spin with more ball speed.



A.I. FACE OPTIMIZED FOR SPEED, LAUNCH AND SPIN

We've applied an all new A.I. face optimization to include speed, launch and spin. This unique face pattern is customized for each model and loft in the fairway lineup.



SPEED AND CONSISTENCY FROM A HIGH STRENGTH FACE CUP

The C300 maraging steel is specially treated through a proprietary process for high strength and flexibility, while the Flash Face Cup provides speed and spin consistency across the face.

WOMENS
ROGUE
ST



WMN ROGUE ST MAX FAIRWAY



PROJECT X CYPHER
40g (WMS)

*Shaft weights indicate weight class



GOLF PRIDE TOUR VELVET 360 (50g)

FAIRWAY SPECS

NAME	LOFT	AVAILABILITY	STANDARD LENGTH	LIE	CC	SWING WEIGHT
3W	15°	RH / LH CUSTOM ONLY	42.00"	58.0°	180	C8
3 HL	16.5°	RH ONLY	42.00"	58.0°	180	C8
5W	18°	RH / LH CUSTOM ONLY	41.50"	56.5°	148	C8
HW	20°	RH ONLY	41.75"	57.0°	153	C8
7W	21°	RH / LH CUSTOM ONLY	41.00"	57.0°	139	C8
9W	24°	RH ONLY	40.50"	58.0°	132	C8
11W	27°	RH ONLY	40.00"	59.0°	127	C8

COMPARISON CHART

	Rogue ST MAX D	Rogue ST MAX	Rogue ST MAX LS
Tungsten Speed Cartridge Structure	20g	26g	23g
Jailbreak AI Speed Frame	Yes	Yes	Yes
Flash Face SS22	Yes	Yes	Yes
Weight Screw	Yes	Yes	Yes
Launch	High	High	Low
Spin	Mid	Mid	Low
Flight Bias	Draw	Semi Draw	Neutral
Forgiveness	Highest	Highest	Highest

ROGUE ST



ROGUE ST MAX HYBRID

The Rogue ST MAX is our longest Rogue ST hybrid model, built with slightly stronger lofts to fit an extensive range of golfers looking for speed, forgiveness, and all-around hybrid performance.

OUR FASTEST FAMILY OF HYBRIDS EVER



SPEED & STABILITY FROM JAILBREAK ST

The new A.I.-designed Jailbreak system has been completely redesigned to promote speed and stability. The two Jailbreak frames are pushed to the perimeter, providing stiffness while allowing the face to flex for high ball speeds.



A.I. FACE OPTIMIZED FOR SPEED, LAUNCH AND SPIN

From our high strength 455 Face Cup, we've applied an all new A.I. face optimization to include speed, launch and spin. This unique face pattern is customized for each model and loft in the hybrid lineup.



OPTIMAL LAUNCH WITH MORE SPEED

Up to 24g of precision tungsten allows for precise Center of Gravity (CG) locations, delivering optimal launch with even more ball speed.

ROGUE ST



ROGUE ST MAX HYBRID



TRUE TEMPER PROJECT X CYPHER BLACK

50g (Light)



MITSUBISHI TENSEI AV BLUE

60g (Reg) • 70g (Stiff)



CALLAWAY UNIVERSAL

SPECS

NAME	LOFT	AVAILABILITY	STANDARD LENGTH	LIE	SWING WEIGHT	NAME	LOFT
3H	18°	RH / LH	40.50"	58.0°	D2	3H	18°
4H	20°	RH / LH	40.00"	58.5°	D2	4H	20°
5H	23°	RH / LH	39.50"	59.0°	D2	5H	23°
6H	26°	RH ONLY	39.00"	59.5°	D2	6H	26°

COMPARISON CHART

TECHNOLOGY	ROGUE ST MAX	ROGUE ST MAX OS	ROGUE ST MAX OS LITE	ROGUE ST PRO
LAUNCH	HIGH	HIGH	HIGHEST	MID
SPIN	MID	MID	HIGH	LOW
FLIGHT BIAS	SEMI-DRAW	DRAW	DRAW	NEUTRAL
FORGIVENESS	HIGH	HIGHEST	HIGHEST	MID
HEAD SHAPE	IRON LIKE	IRON LIKE	IRON LIKE	FAIRWAY WOOD LIKE
FOOTPRINT	MID SIZED	OVERSIZE	OVERSIZE	COMPACT
MODEL CATEGORY	GAME-IMPROVEMENT	GAME-IMPROVEMENT	GAME-IMPROVEMENT	PLAYERS PERFORMANCE

ROGUE
ST**ROGUE ST MAX OS LITE**

The Rogue Max OS Lite family is our easiest to swing light weight option with up to 15g of tungsten, and features our widest loft offering extending from a 3 hybrid to an 8 hybrid.

OUR FASTEST FAMILY OF HYBRIDS EVER

**SPEED & STABILITY FROM JAILBREAK ST**

The new A.I.-designed Jailbreak system has been completely redesigned to promote speed and stability. The two Jailbreak frames are pushed to the perimeter, providing stiffness while allowing the face to flex for high ball speeds.

**A.I. FACE OPTIMIZED FOR SPEED, LAUNCH AND SPIN**

From our high strength 455 Face Cup, we've applied an all new A.I. face optimization to include speed, launch and spin. This unique face pattern is customized for each model and loft in the hybrid lineup.

**OPTIMAL LAUNCH WITH MORE SPEED**

Up to 15g of precision tungsten allows for precise Center of Gravity (CG) locations, delivering optimal launch with even more ball speed.

ROGUE ST



ROGUE ST MAX OS LITE



TRUE TEMPER PROJECT X CYPHER BLACK

50g (Light) • 60g (Reg)



CALLAWAY UNIVERSAL

SPECS

NAME	LOFT	AVAILABILITY	STANDARD LENGTH	LIE	SWING WEIGHT	NAME	LOFT
3H	21°	RH / LH CUSTOM ONLY	40.50"	59.0°	C4	3H	21°
4H	24°	RH / LH	40.00"	59.5°	C4	4H	24°
5H	27°	RH / LH	39.50"	60.0°	C4	5H	27°
6H	30°	RH ONLY	39.00"	60.5°	C4	6H	30°
7H	33°	RH ONLY	38.50"	61.0°	C4	7H	33°
8H	36°	RH ONLY	38.00"	61.5°	C4	8H	36°

COMPARISON CHART

TECHNOLOGY	ROGUE ST MAX	ROGUE ST MAX OS	ROGUE ST MAX OS LITE	ROGUE ST PRO
LAUNCH	HIGH	HIGH	HIGHEST	MID
SPIN	MID	MID	HIGH	LOW
FLIGHT BIAS	SEMI-DRAW	DRAW	DRAW	NEUTRAL
FORGIVENESS	HIGH	HIGHEST	HIGHEST	MID
HEAD SHAPE	IRON LIKE	IRON LIKE	IRON LIKE	FAIRWAY WOOD LIKE
FOOTPRINT	MID SIZED	OVERSIZE	OVERSIZE	COMPACT
MODEL CATEGORY	GAME-IMPROVEMENT	GAME-IMPROVEMENT	GAME-IMPROVEMENT	PLAYERS PERFORMANCE

ROGUE
ST

WOMEN'S ROGUE ST MAX OS LITE HYBRIDS

The Rogue Max OS Lite family is our easiest to swing light weight option with up to 15g of tungsten and features our widest loft offering extending from a 3 hybrid to an 8 hybrid.

OUR FASTEST FAMILY OF HYBRIDS EVER



SPEED & STABILITY FROM JAILBREAK ST

The new A.I.-designed Jailbreak system has been completely redesigned to promote speed and stability. The two Jailbreak frames are pushed to the perimeter, providing stiffness while allowing the face to flex for high ball speeds.



A.I. FACE OPTIMIZED FOR SPEED, LAUNCH AND SPIN

From our high strength 455 Face Cup, we've applied an all new A.I. face optimization to include speed, launch and spin. This unique face pattern is customized for each model and loft in the hybrid lineup.



OPTIMAL LAUNCH WITH MORE SPEED

Up to 15g of precision tungsten allows for precise Center of Gravity (CG) locations, delivering optimal launch with even more ball speed.

ROGUE ST



WOMEN'S ROGUE ST MAX OS LITE HYBRIDS



Project X Cypher Black 40 HB/IR Graphite

40g



CALLAWAY - DIAMOND UNIVERSAL WOMENS BLACK/SILVER (45G)

SPECS

NAME	LOFT	AVAILABILITY	STANDARD LENGTH	LIE	SWING WEIGHT
3H	21°	RH / LH	38.50"	59.0°	C3
4H	24°	RH / LH	38.00"	59.5°	C3
5H	27°	RH / LH	37.50"	60.0°	C3
6H	30°	RH ONLY	37.00"	60.5°	C3
7H	33°	RH ONLY	36.50"	61.0°	C3
8H	36°	RH ONLY	36.00"	61.5°	C3

ROGUE ST



ROGUE ST MAX IRONS

The Rogue ST Max irons are our longest irons ever with refined game-improvement shaping and the strongest lofts in the Rogue ST iron family. They fit a wide range of golfers looking for incredible speed, forgiveness, and all-around iron performance.

OUR LONGEST IRONS EVER



MORE BALL SPEED FROM THE ALL-NEW HIGH STRENGTH 450 A.I. DESIGNED FLASH FACE CUP

An industry-first, we combined high strength 450 steel with our A.I. designed Flash Face Cup. This delivers more ball speed and better ball speed consistency.



NEW A.I. FACE OPTIMIZATION FOR SPEED, LAUNCH AND SPIN

We've applied our new A.I. Face Optimization for Rogue ST MAX. It's unique for each model and loft to create spin rate consistency across the face. It creates high launch and COR plus a more controlled landing angle to help hold greens.



PRECISION TUNGSTEN WEIGHTING FOR OPTIMAL LAUNCH

Our new precision tungsten weighting features up to 62g of high-density tungsten, a 260% increase over MAVRIK. This provides improved launch conditions and also maximizes speed across the face.



PATENTED URETHANE MICROSPHERES FOR PURE FEEL

Our patented urethane microspheres are now pushed further up the face in Rogue ST irons (up to the 6th groove) to enhance sound and deliver pure feel while maintaining fast ball speeds.

ROGUE ST



ROGUE ST MAX IRONS



ELEVATE MPH
95g (Reg, Stiff)



PROJECT X CYPHER
50g (Light)



TENSEI AV BLUE
60g (Reg) • 70g (Stiff)



CALLAWAY UNIVERSAL

SPECS

NAME	LOFT	AVAILABILITY	STANDARD LENGTH	LIE	OFFSET (MM)	GRAPHITE SWING WEIGHT	STEEL SWING WEIGHT
#4	18.5°	RH / LH	38.875"	60.5°	7.0	D0	D2
#5	21.5°	RH / LH	38.25"	61.25°	6.8	D0	D2
#6	24.5°	RH / LH	37.625"	62.0°	6.4	D0	D2
#7	27.5°	RH / LH	37.00"	62.5°	6.1	D0	D2
#8	32°	RH / LH	36.50"	63.0°	5.8	D0	D2
#9	36.5°	RH / LH	36.00"	63.5°	5.3	D0	D2
PW	41°	RH / LH	35.75"	64.0°	4.8	D0	D2
AW	46°	RH / LH	35.50"	64.0°	4.3	D0	D2
GW	51°	RH / LH	35.25"	64.0°	3.7	D0	D2
SW	56°	RH / LH	35.00"	64.0°	3.2	D0	D2

COMPARISON CHART

PERFORMANCE CHARACTERISTICS	ROGUE ST MAX	ROGUE ST MAX OS	ROGUE ST MAX OS LITE	ROGUE ST PRO
LAUNCH	HIGH	HIGH	HIGHEST	MID
FORGIVENESS	HIGH	HIGHEST	HIGHEST	MID-HIGH
SOLE WIDTH	MODERATE	WIDE	WIDE	COMPACT
HEADSHAPE	MODERATE	OVERSIZE	OVERSIZE	COMPACT
MODEL CATEGORY	GAME-IMPROVEMENT	GAME-IMPROVEMENT	GAME-IMPROVEMENT	PLAYERS PERFORMANCE

ROGUE ST



ROGUE ST MAX OS LITE

Rogue ST MAX OS Lite irons have a refined game-improvement shaping, with high launch, wide soles, and enhanced offset. The Lite version features more loft, lighter shafts and lighter swingweights to make these our highest launching, easiest to swing Rogue ST model.

OUR HIGHEST LAUNCHING EASIEST TO SWING IRON



MORE BALL SPEED FROM THE ALL-NEW HIGH STRENGTH 450 A.I. DESIGNED FLASH FACE CUP

An industry-first, we combined high strength 450 steel with our A.I. designed Flash Face Cup. This delivers more ball speed and better ball speed consistency.



NEW A.I. FACE OPTIMIZATION FOR SPEED, LAUNCH AND SPIN

We've applied our new A.I. Face Optimization to Rogue ST MAX OS LITE. It's unique for each model and loft to create spin rate consistency across the face. It delivers high launch and COR plus a more controlled landing angle to help hold greens.



PRECISION TUNGSTEN WEIGHTING FOR OPTIMAL LAUNCH

Our new precision tungsten weighting features up to 49g of high-density tungsten, a 188% increase over MAVRIK. It provides improved launch conditions and maximizes speed across the face.



PATENTED URETHANE MICROSPHERES FOR PURE FEEL

Our patented urethane microspheres are now pushed further up the face in Rogue ST irons (up to the 6th groove) to enhance sound and deliver pure feel while maintaining fast ball speeds.

ROGUE ST



ROGUE ST MAX OS LITE



PROJECT X CYPHER
50g (Light) • 60g (Reg)



CALLAWAY UNIVERSAL

SPECS

NAME	LOFT	AVAILABILITY	STANDARD LENGTH	LIE	OFFSET (MM)	GRAPHITE SWING WEIGHT
#4	22°	RH / LH	38.875"	60.5°	7.6	D0
#5	25°	RH / LH	38.25"	61.25°	7.1	D0
#6	28°	RH / LH	37.625"	62.0°	6.7	D0
#7	31.5°	RH / LH	37.00"	62.5°	6.1	D0
#8	35°	RH / LH	36.50"	63.0°	5.6	D0
#9	39°	RH / LH	36.00"	63.5°	5.0	D0
PW	43°	RH / LH	35.75"	64.0°	4.4	D0
AW	47°	RH / LH	35.50"	64.0°	3.8	D0
GW	51°	RH / LH	35.25"	64.0°	3.1	D0
SW	56°	RH / LH	35.00"	64.0°	2.4	D0

COMPARISON CHART

PERFORMANCE CHARACTERISTICS	ROGUE ST MAX	ROGUE ST MAX OS	ROGUE ST MAX OS LITE	ROGUE ST PRO
LAUNCH	HIGH	HIGH	HIGHEST	MID
FORGIVENESS	HIGH	HIGHEST	HIGHEST	MID-HIGH
SOLE WIDTH	MODERATE	WIDE	WIDE	COMPACT
HEADSHAPE	MODERATE	OVERSIZE	OVERSIZE	COMPACT
MODEL CATEGORY	GAME-IMPROVEMENT	GAME-IMPROVEMENT	GAME-IMPROVEMENT	PLAYERS PERFORMANCE

ROGUE ST



WOMEN'S ROGUE ST MAX OS LITE IRONS

Rogue ST MAX OS Lite irons have a refined game-improvement shaping, with high launch, wide soles, and enhanced offset. The Lite version features more loft, lighter shafts and lighter swingweights to make these our highest launching, easiest to swing Rogue ST model.

OUR HIGHEST LAUNCHING EASIEST TO SWING IRON



MORE BALL SPEED FROM THE ALL-NEW HIGH STRENGTH 450 A.I. DESIGNED FLASH FACE CUP

An industry-first, we combined high strength 450 steel with our A.I. designed Flash Face Cup. This delivers more ball speed and better ball speed consistency.



NEW A.I. FACE OPTIMIZATION FOR SPEED, LAUNCH AND SPIN

We've applied our new A.I. Face Optimization to Rogue ST MAX OS LITE. It's unique for each model and loft to create spin rate consistency across the face. It delivers high launch and COR plus a more controlled landing angle to help hold greens.



PRECISION TUNGSTEN WEIGHTING FOR OPTIMAL LAUNCH

Our new precision tungsten weighting features up to 49g of high-density tungsten, a 188% increase over MAVRIK. It provides improved launch conditions and maximizes speed across the face.



PATENTED URETHANE MICROSPHERES FOR PURE FEEL

Our patented urethane microspheres are now pushed further up the face in Rogue ST irons (up to the 6th groove) to enhance sound and deliver pure feel while maintaining fast ball speeds.

ROGUE ST



WOMEN'S ROGUE ST MAX OS LITE IRONS



PROJECT X CYPHER BLACK
40g



CALLAWAY - DIAMOND UNIVERSAL WOMENS BLACK/SILVER

SPECS

NAME	LOFT	AVAILABILITY	STANDARD LENGTH	LIE	OFFSET (MM)	GRAPHITE SWING WEIGHT
#4	22°	RH / LH	37.875"	60.5°	7.6	C3
#5	25°	RH / LH	37.25"	61.25°	7.1	C3
#6	28°	RH / LH	36.625"	62.0°	6.7	C3
#7	31.5°	RH / LH	36.00"	62.5°	6.1	C3
#8	35°	RH / LH	35.50"	63.0°	5.6	C3
#9	39°	RH / LH	35.00"	63.5°	5.0	C3
PW	43°	RH / LH	34.75"	64.0°	4.4	C3
AW	47°	RH / LH	34.50"	64.0°	3.8	C3
GW	51°	RH / LH	34.25"	64.0°	3.1	C3
SW	56°	RH / LH	34.00"	64.0°	2.4	C3

COMPARISON CHART

PERFORMANCE CHARACTERISTICS	ROGUE ST MAX	ROGUE ST MAX OS	ROGUE ST MAX OS LITE	ROGUE ST PRO
LAUNCH	HIGH	HIGH	HIGHEST	MID
FORGIVENESS	HIGH	HIGHEST	HIGHEST	MID-HIGH
SOLE WIDTH	MODERATE	WIDE	WIDE	COMPACT
HEADSHAPE	MODERATE	OVERSIZE	OVERSIZE	COMPACT
MODEL CATEGORY	GAME-IMPROVEMENT	GAME-IMPROVEMENT	GAME-IMPROVEMENT	PLAYERS PERFORMANCE

APEX 21



Apex 21 Irons

Introducing the NEW Apex 21 Irons. This is an extraordinary level of forged performance and craftsmanship that we've never seen before. It's the first forged iron designed with Artificial Intelligence for faster ball speeds, and that's just the beginning. Our world-class R&D team has improved spin consistency using A.I., increased forgiveness from our massive Tungsten Energy Core, and enhanced the shaping for even better turf interaction. In short, these irons deliver superior performance with iconic feel on every swing



THE FIRST APEX IRON DESIGNED WITH A.I.

Our A.I.-designed Flash Face Cup is in a forged Apex Iron for the first time ever. The unique A.I. architecture in each iron creates high ball speeds and increased spin robustness across the face. They're engineered for impressive distance and pinpoint control.



CONSISTENT LAUNCH AND INCREASED FORGIVENESS

For the first time, we've implemented our Tungsten Energy Core into an Apex Iron. With 5x the tungsten of Apex 19, we can precisely position the Center of Gravity to promote outstanding launch throughout the set, and more forgiveness on off-center shots.



FORGED BLADE FEEL IN A PLAYERS DISTANCE IRON

Apex Irons are renowned for their pure feel, and Apex 21 is no different. The body of the iron is 100% forged from a 1025 mild carbon steel body, and our patented Urethane Microspheres deliver exceptional sound and feel at impact. The improved shaping also helps to enhance feel through the turf.

APEX 21



Apex 21 Irons

TRUE TEMPER ELEVATE ETS

95g (Reg, Stiff)



UST RECOIL DART

70g (Light, Reg, Stiff)

*Shaft weights indicate weight class



GOLF PRIDE Z GRIP SOFT

SPECS

NAME	LOFT	AVAILABILITY	STANDARD LENGTH	LIE	OFFSET (MM)	GRAPHITE SWING WEIGHT	STEEL SWING WEIGHT
#3	19°	RH / LH	39.00"	60.0°	5.08	D0 (LGT & REG); D1 (STIFF)	D2
#4	21°	RH / LH	38.50"	60.5°	4.57	D0 (LGT & REG); D1 (STIFF)	D2
#5	23.5°	RH / LH	38.00"	61.0°	4.06	D0 (LGT & REG); D1 (STIFF)	D2
#6	26.5°	RH / LH	37.50"	61.5°	3.56	D0 (LGT & REG); D1 (STIFF)	D2
#7	30.5°	RH / LH	37.00"	62.0°	3.05	D0 (LGT & REG); D1 (STIFF)	D2
#8	34.5°	RH / LH	36.50"	62.5°	2.79	D0 (LGT & REG); D1 (STIFF)	D2
#9	38.5°	RH / LH	36.00"	63.0°	2.67	D0 (LGT & REG); D1 (STIFF)	D2
PW	43°	RH / LH	35.75"	63.5°	2.54	D0 (LGT & REG); D1 (STIFF)	D2
AW	48°	RH / LH	35.50"	63.5°	2.41	D0 (LGT & REG); D1 (STIFF)	D2

APEX^{PRO}



Apex 21 Pro Irons

Apex Pro is synonymous with Tour distance and performance, from a premium construction that's demonstrably superior and pleasingly different. We've redesigned this iron from the ground up, with an innovative A.I. face architecture and all new forged hollow body construction. Any scratch or single digit handicapper who wants speed and forgiveness in a player's performance iron needs to try the Apex Pro 21.



THE FIRST APEX PRO IRON DESIGNED WITH A.I.

Our A.I. designed Flash Face Cup is in a forged Apex Pro Iron for the first time ever. The unique Flash Face architecture in each iron creates high COR's for fast ball speeds, and improved spin robustness for every club. This set is engineered for the distance you want to see, and better control than you've ever had before.



ULTIMATE FORGED FEEL

This is what extremely soft feel is all about. The all-new forged 1025 hollow body construction and our patented Urethane Microspheres provide a remarkable blend of sound and feel at impact that players expect.



CONSISTENT LAUNCH CHARACTERISTICS AND FORGIVENESS

For the first time, we've implemented a massive Tungsten Energy Core into an Apex Pro Iron. The hollow body construction includes up to 90 grams of tungsten per iron, the most ever in an Apex Iron. This Tungsten Energy Core improves launch characteristics while simultaneously improving forgiveness.

APEX PRO



Apex 21 Pro Irons



TRUE TEMPER ELEVATE ETS

115g (Reg, Stiff, X-Stiff)



MITSUBISHI MMT

85g (Reg), 95G (Stiff), 105g (X-Stiff)

*Shaft weights indicate weight class



GOLF PRIDE Z GRIP

SPECS

NAME	LOFT	AVAILABILITY	STANDARD LENGTH	LIE	OFFSET (MM)	GRAPHITE SWING WEIGHT	STEEL SWING WEIGHT
#3	20.5°	RH / LH	39.00"	60.0°	3.56	D3	D2
#4	23°	RH / LH	38.50"	60.5°	3.43	D3	D2
#5	26°	RH / LH	38.00"	61.0°	3.18	D3	D2
#6	29°	RH / LH	37.50"	61.5°	3.05	D3	D2
#7	33°	RH / LH	37.00"	62.0°	2.80	D3	D2
#8	37°	RH / LH	36.50"	62.5°	2.54	D3	D2
#9	41°	RH / LH	36.00"	63.0°	2.16	D3	D2
PW	45°	RH / LH	35.75"	63.5°	1.90	D3	D2
AW	50°	RH / LH	35.50"	63.5°	1.65	D3	D2

APEX DCB



Apex 21 DCB Irons

Apex Pro is synonymous with Tour distance and performance, from a premium construction that's demonstrably superior and pleasingly different. We've redesigned this iron from the ground up, with an innovative A.I. face architecture and all new forged hollow body construction. Any scratch or single digit handicapper who wants speed and forgiveness in a player's performance iron needs to try the Apex Pro 21.



FORGED FORGIVENESS THROUGH THE SET

Apex DCB is the most forgiving Apex Iron we've ever made. The deep cavity back and enhanced sole width are engineered for easy launch and solid turf interaction out of a variety of lies. Now golfers of all abilities can play a forged iron with confidence.



THE FIRST APEX IRONS DESIGNED WITH A.I.

Our A.I. designed Flash Face Cup is in a forged Apex game-improvement iron for the first time. The unique A.I. face architecture in each iron creates high ball speeds and increased spin robustness. They're engineered for impressive distance and more control than you've ever had.



CONSISTENT LAUNCH AND INCREASED FORGIVENESS

For the first time, we've implemented our Tungsten Energy Core into Apex Irons. The long and mid-irons feature up to 50 grams of tungsten per iron, so we can precisely position the Center of Gravity to promote outstanding launch throughout the set, and more forgiveness on off-center shots.



ULTIMATE FEEL

Apex Irons are renowned for their iconic feel, and Apex DCB is no different. The forged 1025 mild carbon steel body and our patented Urethane Microspheres deliver exceptional sound and feel at impact, while the improved shaping helps enhance feel through the turf.

APEX DCB



Apex 21 DCB Irons



TRUE TEMPER ELEVATE ETS

85g (Reg, Stiff)



UST RECOIL DART

60g (Light, Reg, Stiff)

*Shaft weights indicate weight class



GOLF PRIDE Z GRIP SOFT

SPECS

NAME	LOFT	AVAILABILITY	STANDARD LENGTH	LIE	OFFSET (MM)	GRAPHITE SWING WEIGHT	STEEL SWING WEIGHT
#4	20°	RH / LH	38.75"	60.5°	5.08	D0	D2
#5	23°	RH / LH	38.125"	61.25°	4.57	D0	D2
#6	26°	RH / LH	37.50"	62.0°	4.06	D0	D2
#7	30°	RH / LH	37.00"	62.5°	3.81	D0	D2
#8	34°	RH / LH	36.50"	63.0°	3.56	D0	D2
#9	38°	RH / LH	36.00"	63.5°	3.30	D0	D2
PW	43°	RH / LH	35.75"	64.0°	3.05	D0	D2
AW	48°	RH / LH	35.50"	64.0°	2.79	D0	D2

APEX TCB



Apex TCB Irons

The new Apex TCB Irons are specifically designed for Tour pros and elite golfers. They're precision-engineered for forged performance, shot-making and control in a Tour-inspired forged 1025 players cavity back, with a classic compact look and spec package. This is a truly specialized Apex that's suited for the best players in the game.



EXTREMELY SOFT FEEL

Forged 1025 mild carbon steel body delivers the iconic Apex sound and turf interaction through the ball that the world's best players prefer.



OPTIMUM BALL FLIGHT AND CONTROL

With customized internal and external MIM'd tungsten weighting, we can locate the CG in each iron with extraordinary precision. This internal tungsten promotes optimal shot-making, ball flight, and control for scoring performance through the set. And the external tungsten allows us to precisely dial in swingweight while keeping the CG centered.



PRECISION DISTANCE CONTROL

Apex TCB is engineered with Tour Tuned face plates to promote extremely precise distance control, and consistent performance across the face.



TOUR SHAPING AND DESIGN

A classic look with a straighter leading edge, thin top line, and a smooth hosel transition. Extensive input from the Tour played a significant role in the lofts, offset, and shaping. Apex TCB Irons have a more compact shape with less offset than the X Forged CB Irons.

APEX TCB



Apex TCB Irons

Shaft: Custom Order Only

SPECS

NAME	LOFT	AVAILABILITY	LIE	OFFSET (MM)
#3	20.5°	RH / LH	60.0°	3.2
#4	23°	RH / LH	60.5°	3.0
#5	26°	RH / LH	61.0°	2.8
#6	30°	RH / LH	61.5°	2.5
#7	34°	RH / LH	62.0°	2.3
#8	38°	RH / LH	62.5°	2.0
#9	42°	RH / LH	63.0°	1.0
PW	46°	RH / LH	63.25°	0.5

APEX MB



Apex MB Irons

Our Apex MB Irons are built for the best players in the game. It's a beautiful & classic blade shape with high performance grooves, remarkable feel, and a new weight design. This is a premium muscleback in every way.



TOUR SHAPING AND DESIGN

A classic shape and style, with a traditional, thin topline, refined sole, compact blade length and stunning chrome finish.



HIGH PERFORMANCE 20V GROOVES

Precision grooves are designed to promote the high level of control and consistent spin that muscleback players expect out of any playing conditions. The 20V grooves also stand out for reducing fliers from the rough to deliver even more control.



NEW CG WEIGHTING

We've engineered a new weight in the center of the clubhead. This allows us to precisely dial in swingweights without sacrificing CG location.

APEX MB

SPECS



Apex MB Irons

Shaft: Custom Order Only

NAME	LOFT	AVAILABILITY	STANDARD LENGTH	LIE	OFFSET (MM)	GRAPHITE SWING WEIGHT	STEEL SWING WEIGHT
#3	20.5°	RH / LH	39.00"	60.0°	2.92	CUSTOM ONLY	D2
#4	23°	RH / LH	38.50"	60.5°	2.80	CUSTOM ONLY	D2
#5	26°	RH / LH	38.00"	61.0°	2.67	CUSTOM ONLY	D2
#6	30°	RH / LH	37.50"	61.5°	2.41	CUSTOM ONLY	D2
#7	34°	RH / LH	37.00"	62.0°	2.29	CUSTOM ONLY	D2
#8	38°	RH / LH	36.50"	62.5°	2.03	CUSTOM ONLY	D2
#9	42°	RH / LH	36.00"	63.0°	1.78	CUSTOM ONLY	D2
PW	46°	RH / LH	35.75"	63.3°	1.65	CUSTOM ONLY	D2
AW	50°	RH / LH	35.50"	63.5°	1.40	CUSTOM ONLY	D2

BIG BERTHA REVA



BIG BERTHA REVA DRIVER

DISTANCE DESIGNED FOR WOMEN



DESIGNED FOR WOMEN TO UNLOCK YOUR INNER DISTANCE

We looked extensively at player performance data to build a driver that unlocks your distance. The lofts, swingweights, shafts and head shapes are all optimized to help you hit your tee shots a lot farther. And if you want to hit the ball farther, you have to hit it straighter. So to help eliminate your slice or big miss, we've created our first high launch driver with an ultra-low forward CG for low spin. We hope you're ready for more distance, a more consistent ball flight, and more tee shots that find the fairway.



EASY TO HIT FROM BERTHA SHAPING AND ADDED DRAW BIAS

The high MOI Big Bertha head is specifically engineered with internal draw bias weighting to help improve your launch angles and promote a straighter, longer ball flight.



FAST BALL SPEED FROM OUR A.I. DESIGNED FLASH FACE SS21

We've advanced our A.I. designed Flash Face to promote fast ball speeds across a more expansive area in each model and loft. So you'll still hit it a long way, even when you miss the center of the face at impact.



SUPER STRENGTH TITANIUM FOR CONSISTENT, HIGH BALL SPEEDS

This face architecture requires extremely strong materials that are lighter and stronger than traditional titanium to promote optimal speed, forgiveness, and spin characteristics.



JAILBREAK + T2C TRIAXIAL CARBON CROWN FOR BALL SPEED AND UNCONVENTIONAL FORGIVENESS

Two internal Jailbreak bars stiffen the body of the driver, allowing the face to flex more, while the significantly lighter carbon crown allows us to redistribute weight for higher MOI



PREMIUM COMPONENTS PACKAGE

Features a speed-enhancing RCH 40 Shaft and a premium Lamkin Women's ST Soft Grip.

BIG BERTHA REVA



BIG BERTHA REVA DRIVER



CALLAWAY RCH WOMENS WOODS

40g (WMS) • 50g (WMS)

**Shaft weights indicate weight class*



LAMKIN COMFORT ST SOFT (44g)

SPECS

MODEL	LOFT	AVAILABILITY	STANDARD LENGTH	LIE	SWING WEIGHT	CLUBHEAD VOLUME
10.5°	ADJUSTABLE (9.5°-12.5°)	RH / LH	45.75"	60°	D3 (40/50G)	460CC

12°	ADJUSTABLE (11.5°-14.5°)	RH / LH	45.75"	60°	D3 (40/50G)	460CC
-----	--------------------------	---------	--------	-----	-------------	-------

BIG BERTHA REVA



BIG BERTHA REVA FAIRWAY

DISTANCE DESIGNED FOR WOMEN



DESIGNED FOR WOMEN TO UNLOCK YOUR INNER DISTANCE

We looked extensively at player performance data to build fairway woods that unlock your distance. The lofts, swingweights, and shafts are all optimized to help you hit the ball a lot farther.



EASY TO HIT

Big Bertha REVA is also remarkably forgiving with a shallower face, progressive lengths, and an oversized Bertha shape promote consistent contact and smooth turf interaction.



STRAIGHTER BALL FLIGHT FROM INCREASED OFFSET

We've added offset to reduce slices and promote distance-enhancing draws.



HIGH BALL SPEEDS FROM FLASH FACE SS21 + JAILBREAK TECHNOLOGY

Our advanced A.I. design promotes fast ball speeds across an expansive area of the face while Jailbreak bars connect the crown and sole to increase stiffness and promote even more speed.



PREMIUM COMPONENTS

Features a lightweight RCH shaft, designed by Callaway to specifically enhance swing speed, and a premium Lamkin Women's ST Soft Grip.

BIG BERTHA REVA



BIG BERTHA REVA FAIRWAY



CALLAWAY RCH WOMENS WOODS

40g (WMS) • 50g (WMS)

**Shaft weights indicate weight class*



LAMKIN COMFORT ST SOFT (44g)

SPECS

MODEL	LOFT	AVAILABILITY	STANDARD LENGTH	LIE	SWING WEIGHT	CLUBHEAD VOLUME
3W	16°	RH / LH	42"	57°	C6	170CC
5W	19°	RH / LH	41.25"	58°	C6	137CC
7W	22°	RH / LH	40.5"	59°	C6	135CC
9W	25°	RIGHT ONLY	39.75"	60°	C6	132CC

BIG BERTHA REVA



BIG BERTHA REVA HYBRID

DISTANCE DESIGNED FOR WOMEN



DESIGNED FOR WOMEN TO UNLOCK YOUR INNER DISTANCE

We looked extensively at player performance data to build hybrids that unlock your distance. The lofts, swingweights, and shafts are all optimized to help you hit the ball a lot farther.



FAST BALL SPEEDS FROM FLASH FACE SS21

Fast ball speeds across an expansive area in each model and loft, with our advanced A.I.-designed Flash Face. So you'll hit it long, even if you miss the center of the face at impact.



STRAIGHTER BALL FLIGHT FROM INCREASED OFFSET

We've added more offset to help reduce your slice or big miss. This increased offset helps to promote a straighter ball flight for more distance.



ENHANCED LAUNCH AND TRAJECTORY CONTROL FROM DUAL MIM'ED TUNGSTEN WEIGHTING

Optimized CG for launch and stability from precisely shaped dual MIM'ed tungsten weight.



INCREASED BALL SPEED AND EASY LAUNCH

Features a completely new RCH shaft, designed by Callaway to specifically enhance the Big Bertha offering, with an Active Tip Flag section for easy launch. And it comes stock with a Golf Pride Tour Velvet Soft Grip.



PREMIUM COMPONENTS

Features a completely new RCH shaft, designed by Callaway to specifically increase your swing speed, along with a premium Lamkin ST Grip.

BIG BERTHA REVA



BIG BERTHA REVA HYBRID



CALLAWAY RCH WOMENS WOODS

40g (WMS)

**Shaft weights indicate weight class*



LAMKIN COMFORT ST SOFT (44g)

SPECS

MODEL	LOFT	AVAILABILITY	STANDARD LENGTH	LIE	SWING WEIGHT
4H	24°	RH / LH	39.5"	59.5°	C2
5H	27°	RH / LH	39"	60°	C2
6H	30°	RH / LH	38.5"	60.5°	C2
7H	33°	RIGHT ONLY	38"	61°	C2
8H	36°	RIGHT ONLY	37.5"	61.5°	C2

BIG BERTHA

REVA



BIG BERTHA REVA IRON

Distance Designed For Women



DESIGNED FOR WOMEN TO UNLOCK YOUR INNER DISTANCE

We looked extensively at player performance data to build an irons set that unlocks your distance. The lofts, swingweights, and shafts are all optimized to help you hit the ball a lot farther.



AMAZING FORGIVENESS FROM LEGENDARY BIG BERTHA SHAPING

This club profile that golfers love is engineered to give you more confidence over the ball with noticeably wider soles. For easy launch, lower spin and straighter shots, we've added more offset. Combined with our Flash Face Cup, we've developed a NEW formula for distance and forgiveness in a women's iron.



HIGHER LAUNCH FROM OUR VISIBLE TUNGSTEN ENERGY CORE

We've added a significant amount of custom tungsten weighting. So we can deepen the CG in each iron with extraordinary precision, while still maintaining ball speed in the Flash Face Cup. Now you can get higher launch conditions through the set.



PURE FEEL FROM URETHANE MICROSPHERES

Our patented urethane microspheres comprehensively absorb unwanted vibration for exceptional feel, while also maintaining fast ball speeds.



PREMIUM COMPONENTS

Features a speed-enhancing RCH Shaft and a premium Lamkin Women's ST Soft Grip.

BIG BERTHA REVA



BIG BERTHA REVA IRON



CALLAWAY RCH WOMENS WOODS

40g (WMS)

**Shaft weights indicate weight class*



LAMKIN COMFORT ST SOFT (44g)

SPECS

MODEL	LOFT	AVAILABILITY	STANDARD LENGTH	LIE	OFFSET	GRAPHITE SWING WEIGHT	STEEL SWING WEIGHT
5	25°	RH / LH	37.5"	61.25°	0.305"	C2	N/A
6	28°	RH / LH	37"	62°	0.290"	C2	N/A
7	31.5°	RH / LH	36.5"	62.5°	0.270"	C2	N/A
8	35°	RH / LH	36"	63°	0.240"	C2	N/A
9	39°	RH / LH	35.5"	63.5°	0.215"	C2	N/A
P	44°	RH / LH	35.25"	64°	0.185"	C2	N/A
A	49°	RH / LH	35"	64°	0.150"	C2	N/A
S	54°	RH / LH	34.75"	64°	0.125"	C2	N/A

JAWS

FULL TOE



JAWS FULL TOE WEDGE

JAWS Full Toe wedges combine full face JAWS grooves, offset groove-in-groove technology and an all-new raw face, giving you the spin and control you need to pull off every shot around the greens.

EVERY SHOT IN FULL CONTROL



CONFIDENCE & VERSATILITY

The Full Toe shape provides more face area with an enhanced toe peak. The shaping works with the specialized C-Grind to make short shots around the green easy to hit, especially bunker shots and high flops. This wedge is built to perform on mid and full wedge shots too, with great turf interaction so you can stick it close.



CONTROLLED TRAJECTORY

The JAWS Toe Pad pushes the CG higher, for a design that creates a lower, more controlled trajectory. Our Variable Weight Port System helps us locate the CG away from the heel, for solid contact and enhanced feel.



AVAILABLE IN RAW FACE CHROME AND RAW BLACK

JAWS

FULL TOE



JAWS FULL TOE WEDGE



GRAPHITE: PROJECT X CATALYST

80g



STEEL: TRUE TEMPER DYNAMIC GOLD SPINNER

115g



GRIP: LAMKIN UTX CHARCOAL GRIP

SPECS

LOFT	AVAILABILITY	BOUNCE	SOLE	STANDARD LENGTH	LIE	STEEL SWING WEIGHT	GRAPHITE SWING WEIGHT
54°	RH / LH	12°	C-GRIND	35.25"	64.0°	D3	D2
56°	RH / LH	12°	C-GRIND	35.25"	64.0°	D3	D2
58°	RH / LH	10°	C-GRIND	35.00"	64.0°	D3	D2
60°	RH / LH	10°	C-GRIND	35.00"	64.0°	D3	D2
64°	RH / LH	10°	C-GRIND	35.00"	64.0°	D3	D2

WHITE HOT | OG

WOMEN'S



Legendary Then, Iconic Now

White Hot Insert

The original White Hot formulation, feel, sound and performance are all back in one exceptional two-part urethane insert. Tour players and golfers alike have been asking us to re-introduce it for years, and we've listened.

Milled Surface Finish

Our engineers have combined a rich silver PVD finish with fine milling on all key surfaces. These ultra-premium offerings are unlike anything you've ever seen from a White Hot, and the beautiful designs will appeal to golfers who appreciate the look of a milled putter.

High Performance Shafts and New Grips

Available in a premium steel shaft or our Tour proven, multi-material Stroke Lab shaft in a new pearl white. Both shaft options are precisely fitted in shorter lengths of 32" & 33" with our new slim pistol grip that's specifically designed for women.



The original White Hot formulation, feel, sound and performance are all back in one exceptional two-part urethane insert



WOMENS STEEL SHAFT



GRIPS

Model	Hosel	RH	LH	Loft	Lie	Length	Offset	Toe Hang	Headweight
1	CH	Yes	No	3	70	33 34 35	Full Shaft	41	350
7	S	Yes	No	3	70	33 34 35	¾ Shaft	40	350
2-BALL	DB	Yes	No	3	70	33 34 35	Full Shaft	0	355

WHITE HOT | OG



Legendary Then, Iconic Now

White Hot Insert

The most popular putter insert of all time is back with the original formulation, feel, sound, and performance. When Tour players and recreational golfers asked us to re-introduce it, we listened.

Milled Surface Finish

A rich silver PVD finish, combined with fine milling on the surfaces, gives these putters an ultra-premium look, unlike any White Hot you've seen. They're beautiful and will appeal to golfers that appreciate the look of a milled design.

High Performance Shafts with New Pistol Grip

Available in a premium steel shaft or our red Stroke Lab shaft; both options are fitted with a New Pistol Grip. We've made Stroke Lab stiffer and more stable for even more consistency in your stroke, and your performance. It's winning major championships and dominating at the world's biggest events.

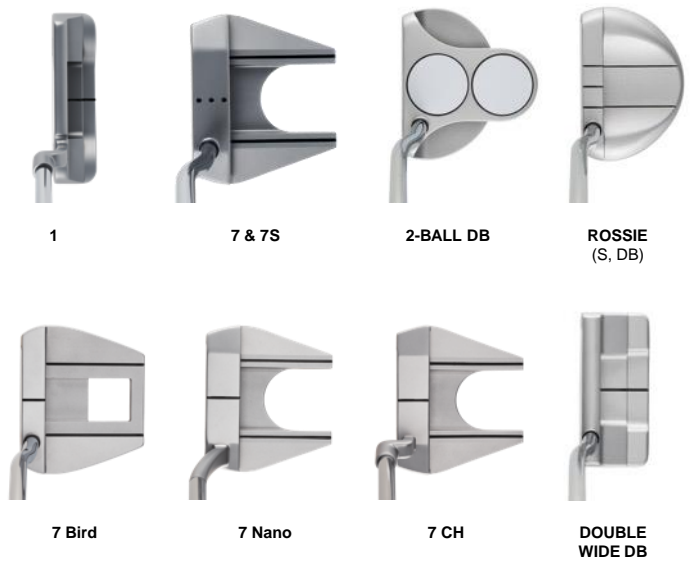

Model	Hosel	RH	LH	Loft	Lie	Length	Offset	Toe Hang	Headweight
1	CH	Yes	Yes	3	70	33 34 35	Full Shaft	41	350/360
7	DB	Yes	Yes	3	70	33 34 35	Full Shaft	0	355/365
7 S	S	Yes	No	3	70	33 34 35	¾ Shaft	40	355/365
2-BALL	DB	Yes	Yes	3	70	33 34 35	Full Shaft	0	355/365
ROSSIE	DB	Yes	No	3	70	33 34 35	Full Shaft	0	355/365
ROSSIE S	S	Yes	No	3	70	33 34 35	¾ Shaft	36	355/365
7 Bird	DB	Yes	No	3	70	33 34 35	Full Shaft	0	355/365
7 Nano	F	Yes	Yes	3	70	33 34 35	¾ Shaft	40	355/365
7 CH	CH	Yes	No	3	70	33 34 35	Full Shaft	20	355/365
Double Wide	DB	Yes	Yes	3	70	33 34 35	Full Shaft	0	350/360

The original White Hot formulation, feel, sound and performance are all back in one exceptional two-part urethane insert.



STROKE LAB SHAFT



GRIPS



Toulon Design putters are developed with an obsessive attention to detail, exacting precision, and Tour-proven performance. They're meticulously crafted to be the best milled putters in the world.



STROKE LAB 3GEN GREEN



Performance and Beauty

Deep Diamond Groove Mill pattern

Deep full face grooves are designed to control sound and feel by channeling vibration. The face also features a medium depth double fly cut to enhance forward roll and feel. With this precise attention to detail, we've created our most consistent and best-rolling Toulon Design putters ever.

Midnight Black Finish

Toulon Design is widely recognized for its premium look and construction. The beautiful black finish is played on Tours worldwide and showcases the meticulous craftsmanship of these finely milled putters.

Stroke Lab Weighting

Innovative multi-material shaft saves 40 grams of weight, which is redistributed to the head and grip end of the putter. Stroke Lab completely rebalances the putter for improved tempo and consistency in the stroke, and this major-winning technology continues to dominate on Tours around the world.

Adjustable Weighting System

Every Toulon Design putter comes with a new two split-weight design that moves the weights forward, and toward the toe and heel. The positioning improves the inertia of the head, while also improving the consistency of impact ratio and forward roll. All of this leads to speed consistency and a high level of performance.



MODEL	HEAD TYPE	LOFT	AVAILABILITY	LENGTH	LIE	OFFSET	TOE HANG	HEAD WEIGHT
SAN DIEGO	BLADE	3°	RH / LH	33", 34", 35"	70.0°	FULL SHAFT	45°	360G
MADISON	BLADE	3°	RH ONLY	33", 34", 35"	70.0°	FULL SHAFT	50°	360G
CHICAGO	BLADE	3°	RH ONLY	33", 34", 35"	70.0°	FULL SHAFT	25°	360G
ATLANTA	MALLET	3°	RH ONLY	33", 34", 35"	70.0°	3/4 SHAFT	45°	360G
MEMPHIS	MALLET	3°	RH ONLY	33", 34", 35"	70.0°	FULL SHAFT	0°	365G
LAS VEGAS DB	MALLET	3°	RH / LH	33", 34", 35"	70.0°	FULL SHAFT	0°	365G
LAS VEGAS H4.5	MALLET	3°	RH ONLY	33", 34", 35"	70.0°	3/4 SHAFT	45°	365G
DAYTONA BEACH	MALLET	3°	RH ONLY	33", 34", 35"	70.0°	FULL SHAFT	10°	365G
LE MANS	MALLET	3°	RH / LH	33", 34", 35"	70.0°	FULL SHAFT	0°	365G



Our Softest Insert Ever

Our Softest Insert Ever

The DFX Insert is 20% softer than White Hot for players who want smooth feel and roll.

Legendary Odyssey Head Shapes

#1, Rossie, #7, 2-Ball and Double Wide.



Odyssey DFX Putter are engineered with our softest insert technology ever to help improve your putting. The DFX insert is actually softer than our legendary White Hot insert for golfers who want smooth feel and roll on the greens. This putter performs and it's available in some of our most legendary models to enhance your alignment, your speed control, and your confidence.



ODYSSEY STEEL



PISTOL AND OS GRIPS

Model	Hosel	Headweight (grams)	Shaft	RH	LH	Lie (deg)	Length (inches)	Toe Hang (deg)	Loft (deg)
One	CH	345	Steel	Yes	Yes	70	33 34 35	38	3
Double Wide	DB	345	Steel	Yes	No	70	33 34 35	0	3
Rossie	DB	345	Steel	Yes	No	70	33 34 35	0	3
Seven	DB	345	Steel	Yes	Yes	70	33 34 35	0	3
2-Ball	DB	345	Steel	Yes	No	70	33 34 35	0	3