



GERSTENBERG SERVICES A/S



Polaron is a registered trademark of Gerstenberg Services A/S and covers the new series of advanced high pressure crystallisation equipment.



GERSTENBERG POLARON PIN ROTOR MACHINE AND POLARON PLASTICATOR

Design

The Polaron pin rotor machine and the Polaron plasticator are designed to meet the hygiene requirements of the food industry, primarily within the oils and fats industry.

The pin rotor machine provides extra kneading and crystallisation to the margarine and shortening products and ensures a superior homogeneous product quality. With the pin rotor it is possible to alter the oil combination and still maintain the properties of the crystallised fat product. The pin rotor speed can be adjusted according to the product recipe in order to ensure the desired product quality.

The high speed plasticator assures a smooth and consistent product filling and for some fat blends a shiny appearance.

The various cylinder sizes of the pin rotor machines and plasticator can be mounted on the same frame and up to three cylinders can be mounted on one frame.

Materials

All product contacting parts are made of stainless steel AISI 316 and product seals are made of semi-balanced type and are of sanitary design according to 3-A Standards.

Cleaning, maintenance and service

The Polaron pin rotor machine and the Polaron plasticator can easily be cleaned and sterilised using CIP and are designed for easy and simple maintenance and servicing.





GERSTENBERG SERVICES A/S

Gerstenberg Polaron pin rotor machine and plasticator		Plasticator type 25 l.	Pin rotor machine type 50 l.	Pin rotor machine type 80 l.	Pin rotor machine type 100 l.	Pin rotor machine type 200 l.
Max. pressure	bar	120	120	120	120	75
Cylinder volume	l.	25	50	80	100	200
Pin rotor speed	rpm	300-900	50-300	50-300	50-300	50-220
Gear motor	kW	11	11	11	11	18.5
PT-100 temperature sensor	-	1 pc.	1 pc.	1 pc.	1 pc.	1 pc.
Water attemperation unit	kW	9	9	9	9	9
Product piping connections	mm	DN40	DN40	DN40	DN40	DN40 / DN50

The above capacities are nominal values and may vary depending on product composition and flow rate.

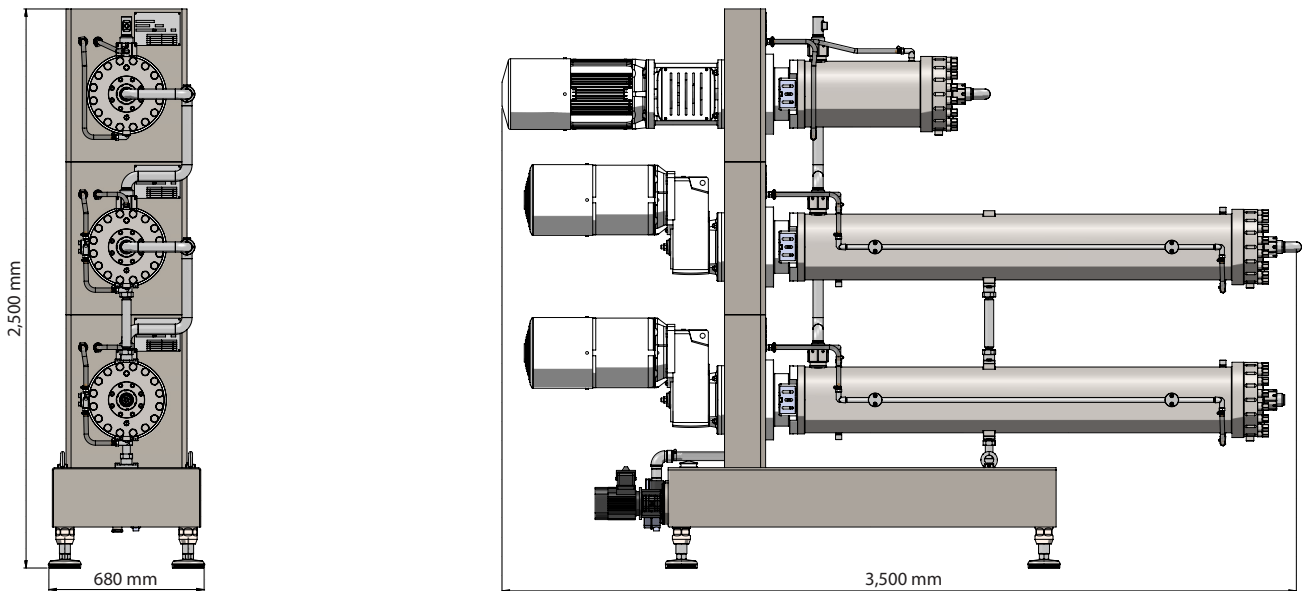

Polaron pin rotor machine 2x80 l. and Polaron plasticator 25 l.