

Video of application



Pipe beveler MF4

Clamping range OD-OD: 38 - 133 mm

The Pipe Beveler MF4 is used for the preparation of pipe ends, cutting of welding edges of individual pipes or membrane walls. Besides the conventional design in which the motor and the milling spindle are arranged in line, the unit can be equipped with an angular drive on request. This allows using the machine in limited spaces. Furthermore, the feed star wheel can be relocated as needed.



Dimensions

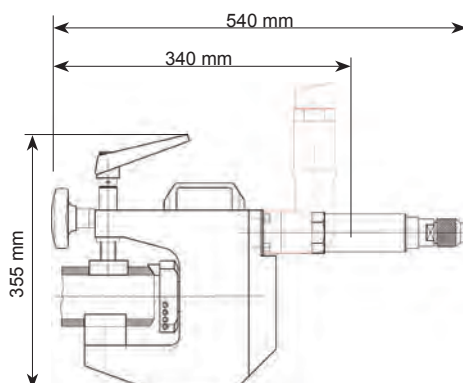
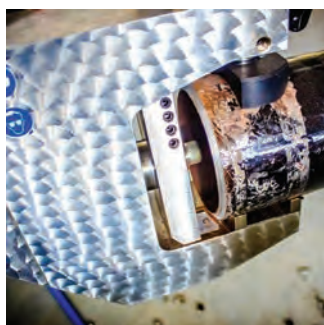

machine width: 79 mm

Specifications

Spezifikationen MF4			Pneumatic Motor		
Working range ID-OD	25 - 133 mm	0,984" - 5,236"	Power	850 W	1,2 HP
Clamping range OD-OD	38 - 133 mm	1,496 - 5,236"	Air pressure	6 bar	87 psi
Max. wall-thickness	25 mm	0,984"	Air consumption	0,96 m ³ /min	33,9 cfm
Feed	15 mm	0,59"	Air hose connection	1/4"	1/4"
Weight with electric motor	14,2 kg	31,75 lb	Features	speed control	
Weight with pneumatic motor	13 kg	26,5 lb	Electric Motor		
Weld prep	facing, V-prep, J-prep, counter boring		Power consumption	1.500 W (110V/230V)	2,0 HP
Materials	steel, stainless steel, duplex, high alloyed		Features	restart and overload protection, speed adjustment, torque control	
Tooling	tool bits, TiN inserts, custom bits				
Machine body	Aluminium alloy				

Accessories & additional options



Toos for MF4-R from page 48



Tube fin removal from page 48



Easy-to-fit Solutions



Angle drive