

Exploded views & spare parts list

Exploded views

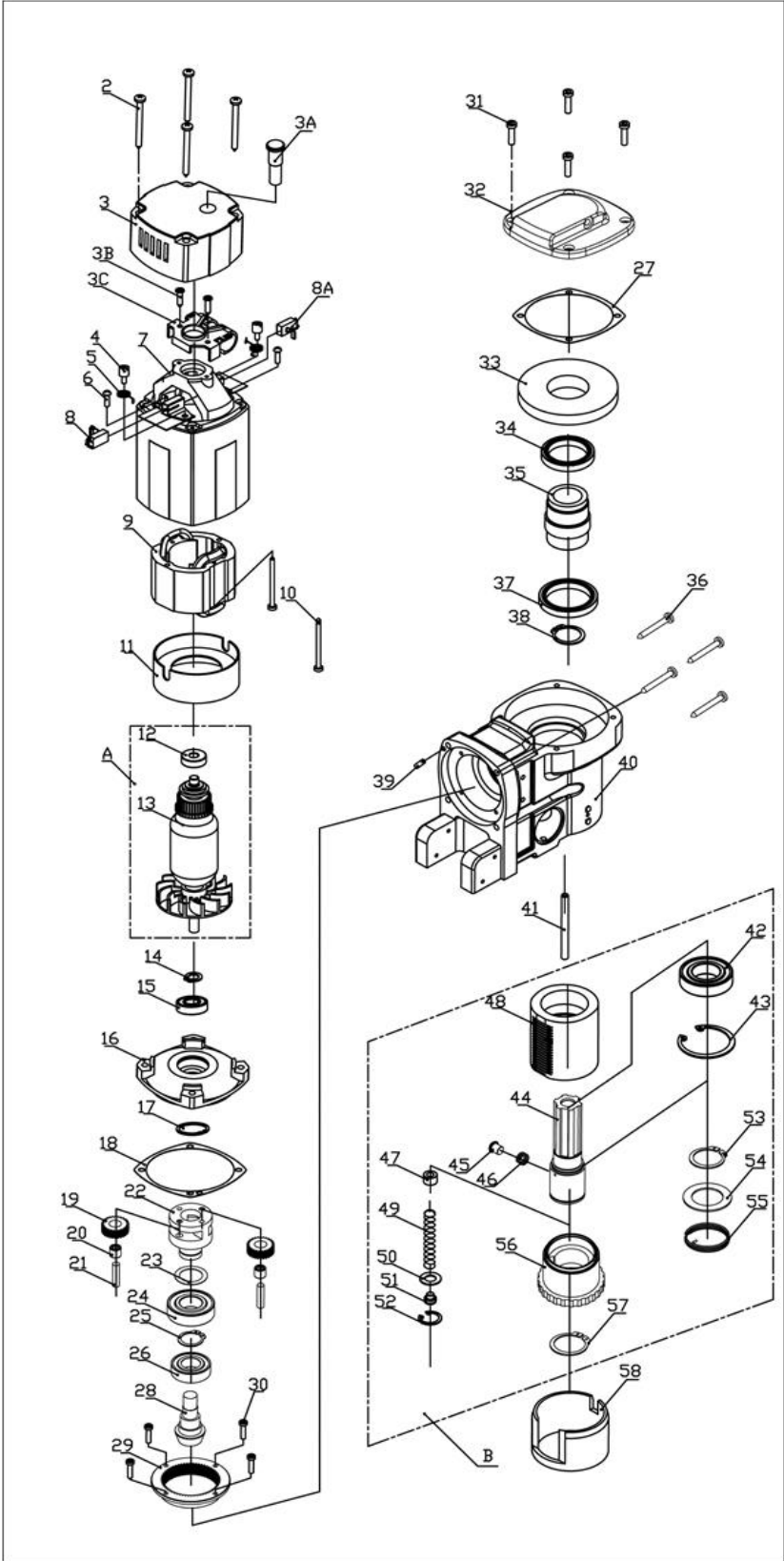

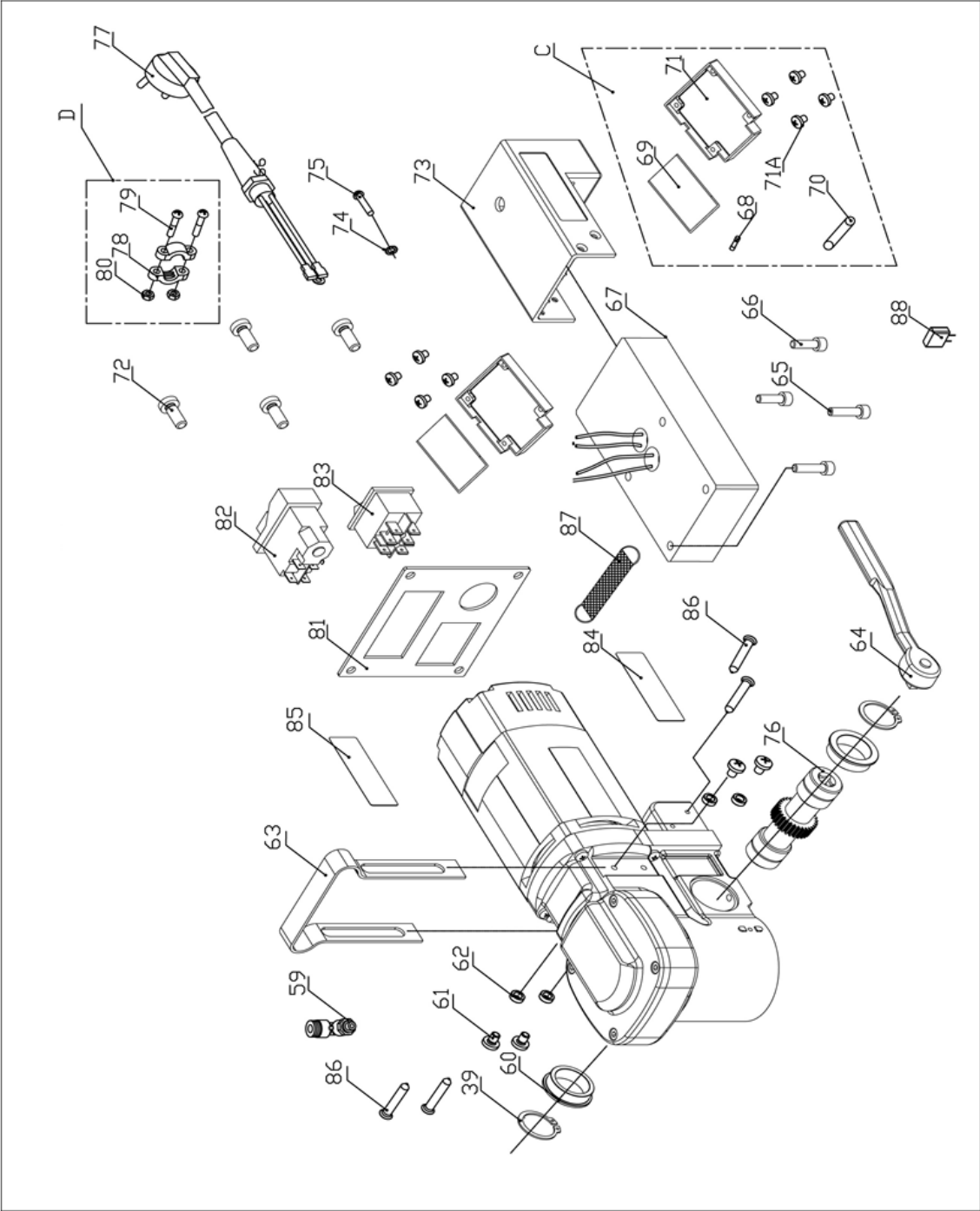

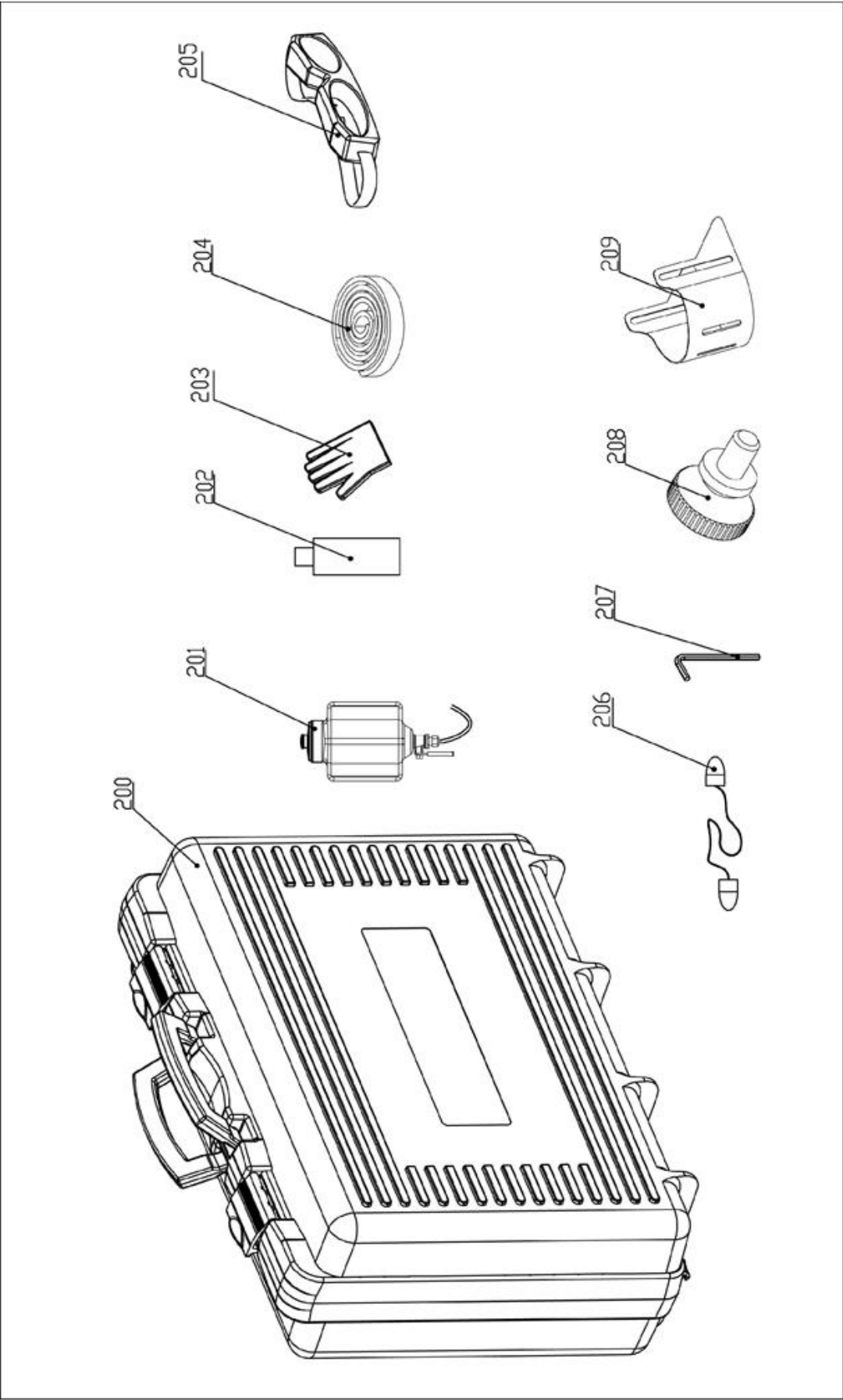

Spare parts list

No.	Art. no.	Description	Qty
1			
2	036.0043	Torx screw M4.8 x 55	4
3	036.0111Z	End cover 110 - 220 Volt	1
3A	020.0278	Led indicator red alarm 110 - 220 Volt	1
3B	032.0116	Screw M4 x 16	2
3C	032.0131	Adapter ring cap	1
4	032.0136	Screw for spring	2
5	032.0141-1	Spring	2
6	020.0101	Panel screw BKVZ M4 x 8	2
7	036.1012	Housing	1
8	032.0146	Carbon brush set 220V	1
	032.0147	Carbon brush set 110V	
8A	032.0146AUTO	Carbon brush 110 - 220 Volt	1
9	036.0047	Field 220V	1
	036.0049	Field 110V	
10	032.0156	Screw BK 4 x 55	2
11	032.0161	Baffle	1
12	032.0126	Bearing 608ZZ 8 x 22 x 7	1
13	036.0046	Armature 220V	1
	036.0048	Armature 110V	
A	036.1017	Armature incl. bearing 220V	1
	036.1018	Armature incl. bearing 110V	
14	100.0571	Circlip 471 11 x 1	1
15	032.0171	Bearing 6001ZZ 12 x 28 x 8	1
16	036.0236	Inner gear plate	1
17	032.0166	Circlip 472/28/1.2	1
18	032.0125	Gasket	1
19	036.0038	Gear 0.8 x 28T	2
20	036.0008	Bearing HK0609	2
21	036.0010	Pin Ø6 x 24	2
22	036.0129	Arbor	1
23	036.0131	Washer	1
24	030E.5034	Bearing nsk 6004 ddu	1
25	050.0076	Circlip Ø20	1
26	032.0196	Bearing 6003 17 x 35 x 10	1
27	036.0138	Gasket	1
28	036.0025	Gear 2 x 11T	1
29	036.0035	Gear 0.8 X 62T	1
30	036.0007	Screw M4 x 8	4
31	036.0012	Screw M5 x 16	4
32	036.0002	Gear plate	1
33	036.0014	Gear 2 x 44T	1

No.	Art. no.	Description	Qty
34	036.0022	Bearing 61807 DDU	1
35	036.0009	Shaft	1
36	036.0044	Torx screw M5 x 45	4
37	036.0023	Bearing 61808 DDU	1
38	036.0018	Circlip Ø25	3
39	050.0025	Pin 4 x 10	2
40	036.0001	Gear box	1
41	036.0017	Tube	1
42			
43			
44			
45			
46			
47			
48			
49			
50	036.2002	Spindle assembly complete	1
51			
52			
53			
54			
55			
56			
57			
45	036.0020	Block	1
46	036.0121	Spring	1
47	036.0013	Sealing	1
58	036.0011	Adapter ring	1
59	KSP.S	Connector	1
60	036.0064	Adapter ring	2
61	036.0028	Screw M5 x 10	4
62	036.0029	Screw	4
63	036.0152	Handle	1
64	036.0026	Spanner	1
65	020.0156	Bolt M6 x 20	2
66	020.0146	Screw M6 x 25	2
67	036.1025	Magnet 220 Volt	1
	036.1025A	Magnet 110 Volt	
68	020.0017	Fuse 5 x 20 F2A	1
68			
69			
70	036.1008Z	Control unit 110 - 220 Volt	1
71			
71A			
72	055.0022	Screw M4 x 12	4
73	036.0003	Cable cover	1
74	040.0286F	Washer M4	1
75	036.0007	Screw M4 x 8	1
76	036.0065	Arm for capstan	1

No.	Art. no.	Description	Qty
77	020.0036	Main cable 220V EU	1
	020.0036/AU	Main cable Australia	
	020.0036/UK	Main cable UK 220v	
	020.0036/UK 110-16A	Main cable UK 110v 16A	
	020.0036/USA	Main cable USA	
	020.0031	Coupling nut PG11 (main cable)	1
78	020.0037	Cable clamp complete	1
79			
80			
81	036.0006	Switch panel ECO.36	1
82	030E.0091/Y	Motor switch 220V (5- pin) YELLOW	1
	030E.0092/Y	Motor switch 110V (5- pin) YELLOW	
83	020.0011-1	Magnet switch	1

No.	Art. no.	Description	Qty
84	036+.0015	Front panel ECO.36+ 220V	1
	036+.0015A	Front panel ECO.36+ 110V	
85	036+.0016	Rear panel ECO.36+	1
86	036.0036	Screw M4 x 10	4
87	036.0040	D-belt	1
88	020.0257	Capacitance	1
200	036+.2010	Case ECO.36+ with sticker	1
201	036.2019	Coolant tank	1
202	IBO.0.2L	Bottle 0.2LTR	1
203	SAF.300	Protective gloves	1
204	036.0033	Safety strap	1
205	SAF.100	Safety goggles	1
206	SAF.200	Ear plugs	1
207	IMB.US3	Allen key 3.0 mm	1
208	036.0027	Screw	2
209	036.0111	Safety guard	1