



OUTDOOR EQUIPMENT

WOOD BURNING OVENS WITH ROOF S SERIES



These wood burning ovens are designed to be easily positioned in the garden or terrace. It's stylish and high quality constructed. The satisfaction of cooking a meal outdoor is incomparable with these wood burning ovens.

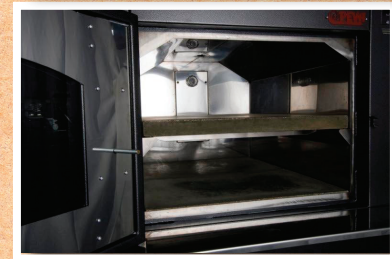
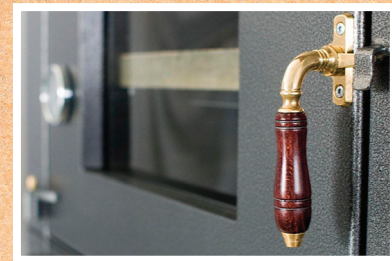

**RANKED AS THE BEST WOOD
BURNING OVEN IN THE MARKET**



Authorized Dealer

Economical and Practical

These wood burning ovens are the most versatile and practical ovens available today on the market. They are designed to cook pizzas, meat, fish, bread, roasted pigs, cakes and more. The particular structure, patented refractory floor and the indirect combustion make our wood-burning ovens to obtain homogeneous distribution of heat. These ovens have a low fuel consumption allowing cost savings and avoiding uncomfortable preheating typically done on traditional wood-burning ovens found on the market today. They are made of high-quality certified food-grade material for safety and hygiene. Our patented wood burning ovens are certified according to the latest regulation **CE UNI 7415-75 UNI 10474** and **UNI EN 563**



Features:

- Low fuel consumption which saves costs and avoids pre-heating like other traditional wood-burning ovens
- Minimal carbon dioxide emission
- Easy installation
- Versatile- it can cook pizza, bread and roast
- Even distribution of heat ensures smoke or ash does not come in contact with food
- Solid structure- long lasting and durable



INDIRECT COMBUSTION

The combustion chamber is located under the cooking chamber and separated from it. The blaze heats the bottom while the smokes of combustion pass through a lateral space. During the process they release heat in to the chamber where they are being warmed up equally. The refractory floor will be then be heated indirectly by flames (irradiation). This ensures that the food does not come in contact with smoke or ash.

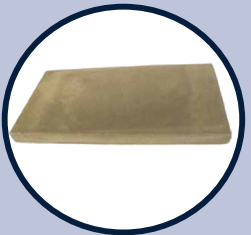

REFRACTORY

Extensive research is conducted for the most suitable elements which resulted the unique refractory cooking floor. The refractory floor stores heat produced by the combustion and evenly release it through the oven surface, which allows optimal cooking. These characteristics make our ovens suitable for cooking products with dough that has high moisture content.

STRUCTURE

Our oven is the only one, which uses an insulation technique: two different types of ecological insulating material, this system allows to keep the heat much longer and maximize the thermal insulation of the external structure. The oven is welded hermetically with a double passage that prevents the smoke from entering the cooking chamber. The external bearing structure can be dismantled which allows for easy cleaning. Each part is specially treated with powder paint resistant to high temperatures, which guarantees no oxidation. The free standing structure is made of high quality raw materials, which makes it long lasting and stable.

OMCAN INC.

Telephone: 1-800-465-0234
Fax: (905) 607-0234
E-mail: sales@omcan.com
Website: www.omcan.com



Follow us to keep up to date with the latest news and offers





OUTDOOR EQUIPMENT

WOOD BURNING OVENS WITH ROOF

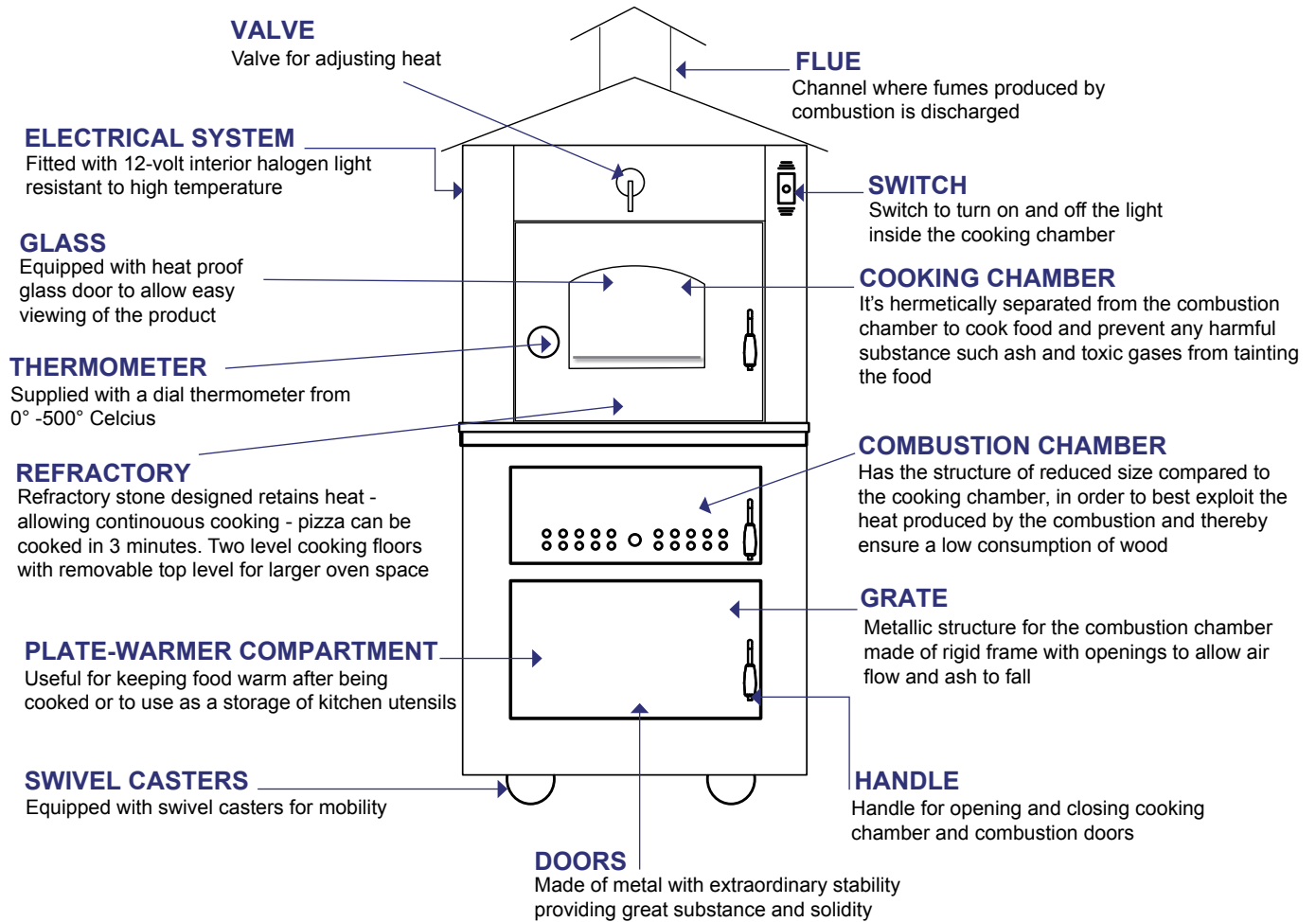

43648



43649



43650



OMCAN INC.

Telephone: 1-800-465-0234
Fax: (905) 607-0234
E-mail: sales@omcan.com
Website: www.omcan.com



Follow us to keep up to date with the latest news and offers



OUTDOOR EQUIPMENT

WOOD BURNING OVENS WITH ROOF

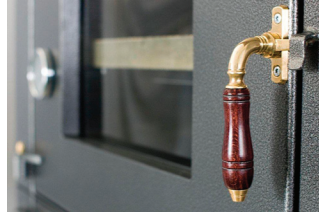

43648 SPECIFICATIONS

ITEM NUMBER	43648
MODEL	WO-IT-0435-S
COOKING CHAMBER DIMENSIONS (L x D)	43.5 x 62 cm 17.1" x 24.4"
OVEN DOOR DIMENSIONS (L x H)	43.5 x 43 cm 17.1" x 16.9"
ROOF DIMENSIONS (L x H)	89 x 93 cm 35" x 36.6"
FLOOR	2
FUEL TYPE	wood
OVEN WEIGHT	301 kg. / 663.6 lbs.
EXTERNAL DIMENSIONS (L x D x H)	72 x 75 x 182 cm 28.3" x 29.5" x 71.7"

43649 SPECIFICATIONS

ITEM NUMBER	43649
MODEL	WO-IT-0435-M
COOKING CHAMBER DIMENSIONS (L x D)	43.5 x 80 cm 17.1" x 31.5"
OVEN DOOR DIMENSIONS (L x H)	43.5 x 43 cm 17.1" x 16.9"
ROOF DIMENSIONS (L x H)	89 x 111 cm 35" x 43.7"
FLOOR	2
FUEL TYPE	wood
OVEN WEIGHT	389 kg. / 857.6 lbs.
EXTERNAL DIMENSIONS (L x D x H)	72 x 93 x 182 cm 28.3" x 36.6" x 71.7"

43650 SPECIFICATIONS

ITEM NUMBER	43650
MODEL	WO-IT-0620-L
COOKING CHAMBER DIMENSIONS (L x D)	62 x 80 cm 24.4" x 31.5"
OVEN DOOR DIMENSIONS (L x H)	62 x 49 cm 24.4" x 19.3"
ROOF DIMENSIONS (L x H)	109 x 111 cm 42.9" x 43.7"
FLOOR	2
FUEL TYPE	wood
OVEN WEIGHT	550 kg. / 1212.5 lbs.
EXTERNAL DIMENSIONS (L x D x H)	90 x 93 x 193 cm 35.4" x 36.6" x 76"

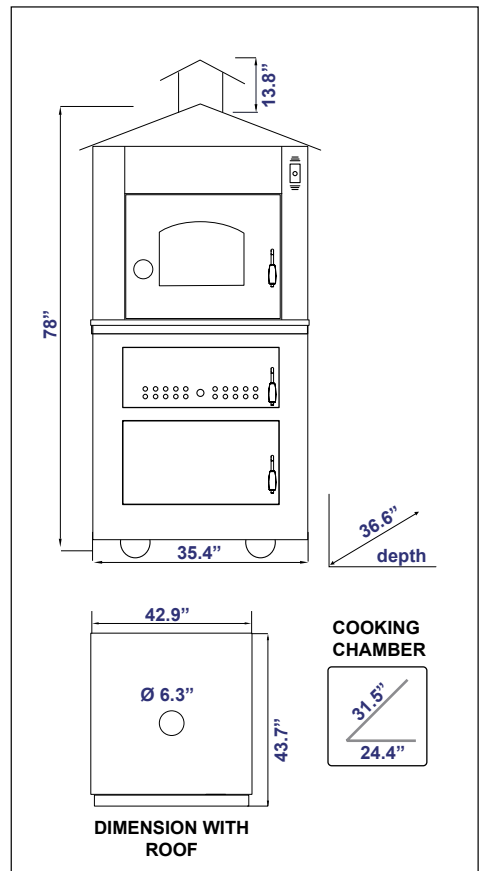
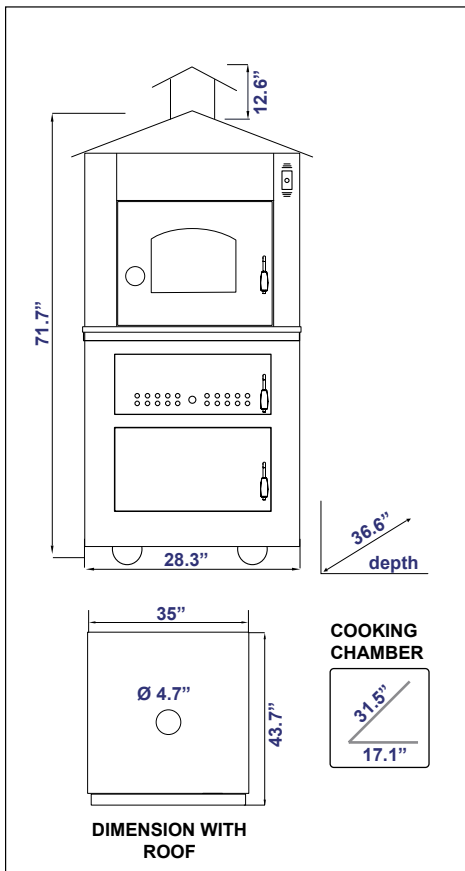
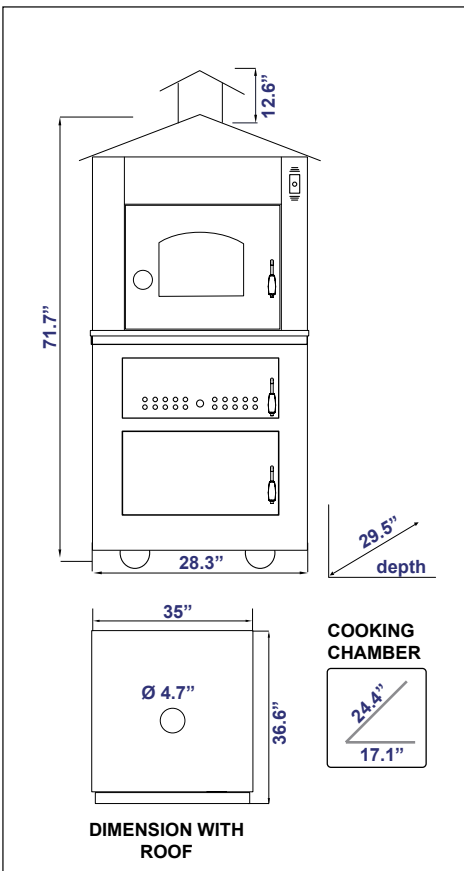

OMCAN INC.

Telephone: 1-800-465-0234
 Fax: (905) 607-0234
 E-mail: sales@omcan.com
 Website: www.omcan.com



Follow us to keep up to date with the latest news and offers

