



Thermo Scientific High-Capacity Section Dryer

User Guide

A84610306 Issue 3

Anatomical Pathology

4481 Campus Drive
Kalamazoo, MI 49008
UNITED STATES
+1 (800) 522-7270

Tudor Road, Manor Park
Runcorn, WA7 1TA
UNITED KINGDOM
+44 (0) 800 018 9396
+44 (0) 1928 534 000

Find out more at thermofisher.com/pathology

ThermoFisher
SCIENTIFIC

ThermoFisher
SCIENTIFIC

Company information

© Copyright 2015. Nickel-Electro Ltd. All rights reserved. Nickel-Electro Ltd is an ISO9001:2008 Accredited Company. Nickel-Electro Ltd is the trading name of Nickel-Electro Ltd. All other trademarks are the property of Nickel-Electro Ltd and its subsidiaries.

Nickel-Electro Ltd makes every endeavor to ensure that the information contained in its support documentation is correct and clearly stated but does not accept responsibility for any errors or omissions. The development of Nickel-Electro Ltd products and services is continuous. Make sure that any published information that you use for reference is up to date and relates to the status of the product. If necessary, check with Nickel-Electro Ltd or your local Nickel-Electro Ltd representative.

This manual may not, in whole or part, be copied, photocopied, reproduced, translated, or converted to any other electronic or instrument readable form without prior consent of Nickel-Electro Ltd.

All information contained in this manual is proprietary and confidential, and the exclusive property of Nickel-Electro Ltd. This manual is protected by copyright and any reproduction is prohibited. This manual is for use only by the individuals to whom it has been made available by Nickel-Electro Ltd.

Contact address



Nickel-Electro Ltd
Oldmixon Crescent, Weston-Super-Mare,
North Somerset, BS24 9BL

For Service or support please contact
The Thermo Shandon Limited
Service Department

Telephone +44 (0) 1928 534 000
Fax +44 (0) 1928 534 049
Web: www.thermoscientific.com/pathology

Distributor

Thermo Shandon Limited
(trading as Thermo Fisher Scientific)
Tudor Road, Manor Park
Runcorn, WA7 1TA, UK

Telephone +44 (0) 1928 534 000
Fax +44 (0) 1928 534 049
Web: www.thermoscientific.com/pathology



These instruments conform to the essential requirements of:

- Low Voltage Directive 2014/35/EU
- EMC Directive 2014/30/EU

Symbols

The following symbols and conventions may be used throughout this document and on the instrument:



This symbol is used on the equipment, or in a document, to indicate that instructions must be followed for safe and correct operation. If this symbol appears on the instrument always refer to the operator guide.



This symbol indicates that a surface is hot. If this symbol appears on the instrument or in the documentation always refer to the operator guide. Take suitable precautions.



Manufacturer

A warning is given in the documentation if there is a danger of personal injury or damage to equipment or samples.

Note: Notes give additional information about a job or instruction, but do not form part of the instruction.





EC Declaration of Conformity

We herewith confirm the following products:

- High-Capacity Section Dryer 230 V - A84600050
- High-Capacity Section Dryer 110 V - A84600051
- High-Capacity Section Dryer 230 V (China Mains Lead) - A84600052

Conforms with requirements outlined by the following European Directives:

- Low Voltage Directive 2014/35/EU
- EMC Directive 2014/30/EU
- RoHS Directive 2011/65/EU

We confirm the declaration:

Nickel Electro Ltd
Oldmixon Crescent
Weston Super Mare
North Somerset
BS24 9BL
United Kingdom

Conforms with the requirements of the following standards:

- BS EN 61010-1: 2010
- BS EN 61010-2-010: 2014
- Safety requirements for electrical equipment for measurement, control and laboratory use.
- BS EN 61326-1: 2013
- Electrical equipment for measurement control and laboratory use - EMC requirements.



General notes

This product is designed for laboratory use only. Always follow good laboratory practice.

If this product is not used in accordance with these instructions then basic safety protection may be affected.

The mains supply cord fitted to this product is heat resistant and should be replaced with an equivalent type.

Before using any cleaning or decontamination method please refer to the Maintenance and Cleaning section to ensure the proposed method will not damage the unit.

Connect only to a power supply with the corresponding voltage to that specified on the rating label positioned on the rear of the unit.

Ensure that the power supply has an earth (ground) terminal.

Specimen safety

It is the users responsibility, to ensure that the temperature set on the instrument, is at a level where no damage is caused to diagnostic specimens used with the equipment. In the event of this instrument malfunctioning, all specimens within the device should be checked to ensure no harm or damage to the specimen has been caused.

User safety

The equipment you have purchased complies with the European EMC Directives and Low Voltage Directive as indicated in the EC Declaration of Conformity included in the document.

This instrument has been designed and constructed in a manner which minimises the risk of electrical shock to the operator, offers maximum protection from overheating and provides clear and adequate labelling of instrument controls.

The instrument requires no regular servicing, but Nickel-Electro Ltd do recommend an annual inspection, as detailed in the manual which will prolong the life of the instrument to ensure continued safety.



Do not touch any electrical contacts or open any closure plates.
RISK OF ELECTRIC SHOCK!!

Specification

Dimensions: Width 469 mm x Depth 320 mm (including handle) x Height 346 mm

Chamber: Width 437 mm x Depth 240-270 mm x Height 198 mm

Capacity: Up to 13 slide racks (dependent upon slide rack width)

Weight: 15.35 Kg

Temperature range: Ambient to 70 °C (+/-1 °C) at 20 °C

Display: Digital display with 0.5 °C accuracy

Safety: Class 1 cut out

Heater power: 1000 watts

Power supply: 220-240 V 50/60 Hz - A84600050

110-120 V 50/60 Hz - A84600051

220-240 V 50/60 Hz (China) - A84600052

Environment

This instrument is required to comply with the European Union's Waste Electrical and Electronic Instrument (WEEE) Directive 2002/96/EC. It is marked with the following symbol:



Thermo Fisher Scientific has contracts with one or more recycling / disposal companies in each EU Member State, and this product should be disposed of or recycled through them. For further information contact your Thermo Fisher Scientific service representative.

Miniature circuit breakers

Located on the rear of the appliance. In the event of a fault, push back in to reset. If fault condition continues, please contact your Service Engineer.

Portable appliance testing

Portable appliance testing should be carried out by a qualified person.



THIS EQUIPMENT MUST NOT BE FLASH TESTED!

Safety cutout

Each fan is protected by a safety cut out, if the section dryer goes into a fault condition due to overheating. Heating will cease and display will turn blank. The unit will naturally cool allowing safety cut out to reset returning it to normal operation after a short period. Please investigate the cause! Should after a prolonged period the unit still not return to normal operation it can be reset by a qualified engineer.

Recommended checks to be made:

1. Check sufficient space at rear of unit for fan ventilation and airflow.
2. Check vents are not obstructed and mesh filters are clean.
3. Check tray is fitted correctly.
4. Do not overload or obstruct tray holes.

Latching safety cutout

The latching safety cutout operates if the section dryer goes into fault condition due to overheating. Heaters will cease and display will turn blank. The safety cutout must be reset by a qualified engineer.

Recommended checks to be made:

1. Check fans are operating correctly.

Routine inspection recommendations

Nickel-Electro Ltd recommend that a simple annual inspection be made for all Thermo Scientific laboratory equipment. This is to ensure user safety and prolong instrument life span.

Recommended checks to be made:

1. Condition of Power Lead: a visual inspection to ensure the insulation is not damaged and that the correct fuse is fitted.
2. Functioning of Heater On Lamp: heater lamp should be on when the instrument is warming up.
3. Functioning of Airflow Fans: all fans at the rear of the section dryer should operate. All fans should begin to operate as soon as the instrument is plugged into a power socket. All fans should spin freely with no indication of rubbing/friction.
4. Covers: check for dust and clean as required.

Cleaning instructions

Regular cleaning of the instrument according to the cleaning instructions enclosed in this user manual will ensure that the instrument continues to operate efficiently and safely in normal everyday use. Cleaning or decontamination methods, other than those recommended in this guide, should be checked with your instrument supplier to ensure that the proposed method will not damage the instrument.

1. The case work and door of the High-Capacity Section Dryer, including the control panel, may be wiped using small quantities of mild detergent or polishes applied with a soft cloth.
2. The Section Dryer chamber will require cleaning at regular intervals, using a minimal quantity of mild domestic detergent applied with a soft synthetic sponge.



SCOURING PADS OR DE-SCALING AGENTS MUST NOT BE USED TO CLEAN THIS INSTRUMENT.



DO NOT USE SOLVENTS TO CLEAN THIS INSTRUMENT!

Do's and Dont's

DO NOT use for drying slides mounted using a flammable mounting medium.

DO NOT stack cardboard slide trays in the chamber.

DO NOT use for purposes which are not specified by the manufacturer without first consulting the supplier.

NO NOT be concerned if the unit emits a strong smell when first used – this is normal and will soon disappear.

DO position the unit so it can be disconnected from the power supply with ease.

DO maintain the instrument in a reasonably clean condition.

DO switch off before removing the plug.

DO use in a safe and stable location.

Power lead and connection to electrical supply



Check the electrical supply is compatible with the rating label.

IF IN DOUBT CONSULT AN ELECTRICIAN. THE PRODUCT MUST BE EARTHED!

Where the mains supply or plug connection differs, refer to local regulations or consult an electrician.

Location

The product must be placed on a smooth, level and sturdy work surface. Suitable for use in ambient temperatures 5 °C to 40 °C with a maximum humidity 80% (temperature 31 °C) decreasing to 50% (temperature 40 °C).

Operating instructions

1. Place the High-Capacity Section Dryer on a smooth and level work surface.
2. Connect the mains lead and switch on. NOTE: as the socket is switched on, the fans on the rear will begin to operate. This ensures an airflow passing through the elements allowing more efficient heating and more rapid cooling when switched off.
3. Set the desired temperature (recommended temperature 60°C).
 - A. Press the DOWN arrow then release it (do not hold down the DOWN arrow continuously for 5 seconds). If you hold the button for 5 seconds, do not press any other button for 20 seconds.
 - B. The display will show SP1 alternating with the current set temperature.
 - C. To change the set temperature press the UP key to increase the value or the DOWN key to decrease it. These keys increase or decrease the value one digit at a time, but if the button is pressed for more than one second the value increases/decreases rapidly and after two seconds pressed, the speed increases even more to allow the desired values to be reached rapidly.
 - D. Exiting the Set mode is achieved by pressing the P key or automatically if no key is pressed for 15 seconds. After that time the display returns to the normal function mode.
4. The display returns to the normal function mode and the heater indicator will illuminate to show heater activity.
5. The instrument will then warm up quickly (approx. 9 minutes to reach 60°C). When first turned on, the instrument will undergo a warm up program in order to maintain temperature control. This tuning program involves the instrument over shooting and under shooting the set temperature. Once the tuning program is complete the set temperature will be maintained.
6. The instrument is designed to warm up quickly (approx. 9 minutes to reach 60°C).
7. It is recommended that when the unit is first turned on after reaching set temperature it should be left for approx. 20 minutes before use to allow the dryer chamber to fully equilibrate to the set temperature.
8. As slide racks are placed or removed from the chamber, the door will be open, and this will result in a drop in temperature from the set value. Once the door is closed the chamber will quickly return to set temperature.



Operation

1. Ensure the Drip Tray is installed correctly with the FRONT facing forward.

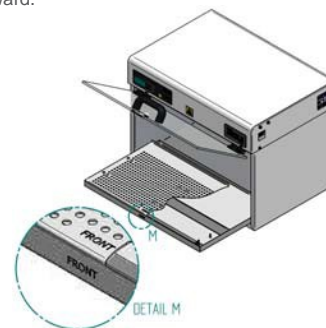

2. If the door of the Section Dryer will not fully close the Drip Tray is inserted the wrong way around. Remove and reinsert correctly so the door closes and the magnet attaches.
3. The position of the 3rd baffle can be moved to meet the users drying preferences. Moving the 3rd baffle to the position indicated in the image below, maximises airflow to the central region of the drip tray.

